

LM2757 Switched-Capacitor Boost Regulator With High Impedance Output in Shutdown

1 Features

- Dual Gain Converter (2×, 3/2×) With up to 93% Efficiency
- Inductorless Solution Uses Only 4 Small Ceramic Capacitors
- Total Solution Area < 12 mm²
- True Input-Output and Output-Input Disconnect
- Up to 180-mA Output Current Capability (5 V)
- Selectable 4.1-V, 4.5-V or 5-V Output
- Pre-Regulation Minimizes Input Current Ripple
- 1.24-MHz Switching Frequency for Low-Noise, Low-Ripple Output Voltage
- Integrated Overcurrent and Thermal Shutdown Protection

2 Applications

- USB/USB-OTG/HDMI Power
- Supercapacitor Charger
- Keypad LED Drive
- Audio Amplifier Power Supply
- Low-Current Camera Flash
- General Purpose Li-Ion-to-5-V Conversion
- Cellular Phone SIM Cards

3 Description

The LM2757 is a constant-frequency pre-regulated switched-capacitor charge pump that operates at 1.25 MHz to produce a low-noise regulated output voltage. The device can be configured to provide up to 100 mA at 4.1 V, 110 mA at 4.5 V, or 180 mA at 5 V. Excellent efficiency is achieved without the use of an inductor by operating the charge pump in a gain of either 3/2 or 2 according to the input voltage and output voltage option selection.

The LM2757 presents a high impedance at the V_{OUT} pin when shut down. This allows for use in applications that require the regulated output bus to be driven by another supply while the LM2757 is shut down.

The LM2757 device comes in a tiny 12-pin 0.4-mm pitch DSBGA package. A perfect fit for space-constrained, battery-operated applications, the device requires only 4 small, inexpensive ceramic capacitors. Built-in soft-start, overcurrent protection, and thermal shutdown features are also included in this device.

Device Information⁽¹⁾

PART NUMBER	PACKAGE	BODY SIZE (MAX)
LM2757	DSBGA (12)	1.641 mm × 1.581 mm

(1) For all available packages, see the orderable addendum at the end of the data sheet.

Typical Application

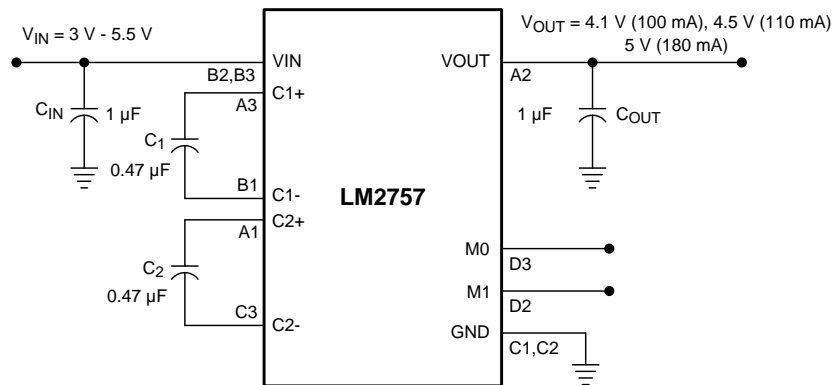

*Bump D1 is No Connect (NC)



Table of Contents

1 Features 1 2 Applications 1 3 Description 1 4 Revision History 2 5 Device Options 3 6 Pin Configuration and Functions 3 7 Specifications 4 7.1 Absolute Maximum Ratings 4 7.2 ESD Ratings 4 7.3 Recommended Operating Conditions 4 7.4 Thermal Information 4 7.5 Electrical Characteristics 5 7.6 Typical Characteristics 6 8 Detailed Description 10 8.1 Overview 10 8.2 Functional Block Diagram 10 8.3 Feature Description 10	8.4 Device Functional Modes 11 9 Application and Implementation 13 9.1 Application Information 13 9.2 Typical Application 13 10 Power Supply Recommendations 18 11 Layout 19 11.1 Layout Guidelines 19 11.2 Layout Example 19 12 Device and Documentation Support 20 12.1 Device Support 20 12.2 Documentation Support 20 12.3 Community Resources 20 12.4 Trademarks 20 12.5 Electrostatic Discharge Caution 20 12.6 Glossary 20 13 Mechanical, Packaging, and Orderable Information 21
--	--

4 Revision History

NOTE: Page numbers for previous revisions may differ from page numbers in the current version.

Changes from Revision E (May 2013) to Revision F	Page
<ul style="list-style-type: none"> • Added <i>Device Information</i> and <i>Pin Configuration and Functions</i> sections, <i>ESD Rating</i> table, <i>Feature Description</i>, <i>Device Functional Modes</i>, <i>Application and Implementation</i>, <i>Power Supply Recommendations</i>, <i>Layout</i>, <i>Device and Documentation Support</i>, and <i>Mechanical, Packaging, and Orderable Information</i> sections. 	1

Changes from Revision D (May 2013) to Revision E	Page
<ul style="list-style-type: none"> • Changed layout of National Data Sheet to TI format 	18

5 Device Options

Table 1. Mode Selection Definition

M0	M1	OUTPUT VOLTAGE MODE
0	0	Device shutdown, output high impedance
0	1	5 V
1	0	4.5 V
1	1	4.1 V

6 Pin Configuration and Functions

YFQ Package
12-Pin DSBGA
Top View (left); Bottom View (right)

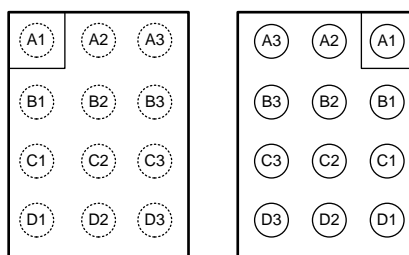
Pin Functions

PIN		TYPE	DESCRIPTION
NUMBER	NAME		
A1	C2+	Power	Flying Capacitor C2 Connection
A2	VOUT	Power	Regulated Output Voltage
A3	C1+	Power	Flying Capacitor C1 Connection
B1	C1–	Power	Flying Capacitor C1 Connection
B2	VIN	Power	Input Voltage Connection
B3	VIN	Power	Input Voltage Connection
C1	GND	Ground	Ground Connection
C2	GND	Ground	Ground Connection
C3	C2–	Ground	Flying Capacitor C2 Connection
D1	NC	NC	No Connect — Do not connect this pin to any node, voltage or GND. Must be left floating.
D2	M1	Logic input	Mode select pin 1
D3	M0	Logic input	Mode select pin 0

7 Specifications

7.1 Absolute Maximum Ratings

 over operating free-air temperature range (unless otherwise noted)⁽¹⁾⁽²⁾⁽³⁾

	MIN	MAX	UNIT
VIN pin: voltage to GND	-0.3	6	V
M0, M1 pins: voltage to GND	-0.3	6	V
Continuous power dissipation ⁽⁴⁾	Internally Limited		
Junction temperature, T _{J-MAX}		150	°C
Maximum lead temperature (soldering, 10 sec.)		265	°C
Storage temperature, T _{stg}	-65	150	°C

- (1) Stresses beyond those listed under *Absolute Maximum Ratings* may cause permanent damage to the device. These are stress ratings only, which do not imply functional operation of the device at these or any other conditions beyond those indicated under *Recommended Operating Conditions*. Exposure to absolute-maximum-rated conditions for extended periods may affect device reliability.
- (2) If Military/Aerospace specified devices are required, please contact the TI Sales Office/ Distributors for availability and specifications.
- (3) All voltages are with respect to the potential at the GND pins.
- (4) Internal thermal shutdown circuitry protects the device from permanent damage. Thermal shutdown engages at T_J = 145°C (typical) and disengages at T_J = 135°C (typical).

7.2 ESD Ratings

	VALUE	UNIT
V _(ESD) Electrostatic discharge Human-body model (HBM), per ANSI/ESDA/JEDEC JS-001 ⁽¹⁾	±2500	V

- (1) JEDEC document JEP155 states that 500-V HBM allows safe manufacturing with a standard ESD control process.

7.3 Recommended Operating Conditions

 over operating free-air temperature range (unless otherwise noted)⁽¹⁾⁽²⁾

	MIN	NOM	MAX	UNIT
Input voltage	2.7		5.5	°C
Junction temperature, T _J	-30		110	°C
Ambient temperature, T _A ⁽³⁾	-30		85	°C

- (1) Stresses beyond those listed under *Absolute Maximum Ratings* may cause permanent damage to the device. These are stress ratings only, which do not imply functional operation of the device at these or any other conditions beyond those indicated under *Recommended Operating Conditions*. Exposure to absolute-maximum-rated conditions for extended periods may affect device reliability.
- (2) All voltages are with respect to the potential at the GND pins.
- (3) In applications where high power dissipation and/or poor package thermal resistance is present, the maximum ambient temperature may have to be derated. Maximum ambient temperature (T_{A-MAX}) is dependent on the maximum operating junction temperature (T_{J-MAX-OP} = 125°C), the maximum power dissipation of the device in the application (P_{D-MAX}), and the junction-to-ambient thermal resistance of the part/package in the application (R_{θJA}), as given by the following equation: T_{A-MAX} = T_{J-MAX-OP} - (R_{θJA} × P_{D-MAX}).

7.4 Thermal Information

THERMAL METRIC ⁽¹⁾	LM2757	UNIT
	YFQ (DSBGA)	
	12 PINS	
R _{θJA} Junction-to-ambient thermal resistance	75	°C/W

- (1) For more information about traditional and new thermal metrics, see the *Semiconductor and IC Package Thermal Metrics* application report, [SPRA953](#).

7.5 Electrical Characteristics

Unless otherwise specified, typical (TYP) limits in apply for $T_A = 25^\circ\text{C}$; minimum (MIN) and maximum (MAX) limits apply over the full operating ambient temperature range ($-30^\circ\text{C} \leq T_A \leq +85^\circ\text{C}$). Unless otherwise noted, specifications apply to *Typical Application* with: $V_{IN} = 3.6\text{ V}$, $V(M0) = 0\text{ V}$, $V(M1) = V_{IN}$, $C_{IN} = C_2 = 0.47\ \mu\text{F}$, $C_{IN} = C_{OUT} = 1\ \mu\text{F}$.⁽¹⁾⁽²⁾⁽³⁾

PARAMETER	TEST CONDITIONS	MIN	TYP	MAX	UNIT	
V_{OUT}	Output voltage	$3.2\text{ V} \leq V_{IN} \leq 5.5\text{ V}$ $-30^\circ\text{C} \leq T_A \leq +60^\circ\text{C}$ $I_{OUT} = 0\text{ to }180\text{ mA}$ $V(M0) = 0\text{ V}$, $V(M1) = V_{IN}$	4.870 (-2.6%)	5	5.130 (2.6%)	V
		$3\text{ V} \leq V_{IN} \leq 5.5\text{ V}$ $-30^\circ\text{C} \leq T_A \leq +85^\circ\text{C}$ $I_{OUT} = 0\text{ to }150\text{ mA}$ $V(M0) = 0\text{ V}$, $V(M1) = V_{IN}$	4.865 (-2.7%)	5	5.130 (2.6%)	
		$3\text{ V} \leq V_{IN} \leq 5.5\text{ V}$ $I_{OUT} = 0\text{ to }110\text{ mA}$ $V(M0) = V_{IN}$, $V(M1) = 0\text{ V}$	4.406 (-2.1%)	4.5	4.613 (2.5%)	
		$3\text{ V} \leq V_{IN} \leq 5.5\text{ V}$ $I_{OUT} = 0\text{ to }100\text{ mA}$ $V(M0) = V_{IN}$, $V(M1) = V_{IN}$	3.985 (-2.8%)	4.1	4.223 (3%)	
I_Q	Quiescent supply current	$V(M0) = 0\text{ V}$, $V(M1) = V_{IN} (5\text{ V})$ $I_{OUT} = 0\text{ mA}$ $V_{IN} = 3.6\text{ V}$		2.4	2.79	mA
		$V(M0) = V_{IN}$, $V(M1) = 0\text{ V} (4.5\text{ V})$ $I_{OUT} = 0\text{ mA}$ $V_{IN} = 3.6\text{ V}$		1.5	1.80	
		$V(M0) = V_{IN}$, $V(M1) = V_{IN} (4.1\text{ V})$ $I_{OUT} = 0\text{ mA}$ $V_{IN} = 3.6\text{ V}$		1.3	1.65	
I_{SD}	Shutdown supply current	$V(M0) = 0\text{ V}$, $V(M1) = 0\text{ V}$ $V_{IN} = 3.6\text{ V}$		1.1	2	μA
V_R	Output ivoltage rpple	$I_{OUT} = 150\text{ mA}$ $V(M0) = 0\text{ V}$, $V(M1) = V_{IN} (5\text{ V})$ $3\text{ V} \leq V_{IN} \leq 5.5\text{ V}$		20		mVp-p
f_{SW}	Switching frequency	$3\text{ V} \leq V_{IN} \leq 5.5\text{ V}$	0.932 (-25%)	1.242	1.552 (+25%)	MHz
V_{IN}	Logic input high	Input pins: M1, M0 $3\text{ V} \leq V_{IN} \leq 5.5\text{ V}$		1	V_{IN}	V
V_{IL}	Logic input low	Input pins: M1, M0 $3\text{ V} \leq V_{IN} \leq 5.5\text{ V}$		0	0.40	V
$R_{PULLDOWN}$	Logic input pulldown resistance (M0, M1)	$V(M1, M0) = 5.5\text{ V}$		324	457	k Ω
I_{IH}	Logic input high current	Input Pins: M1, M0 $V(M1, M0) = 1.8\text{ V}^{(4)}$		5		μA
I_{IL}	Logic input low current	Input Pins: M1, M0 $V(M1, M0) = 0\text{ V}$		10		nA
V_G	Gain transition voltage	$1.5\times\text{ to }2\times$, $V(M0) = V_{IN}$, $V(M1) = 0\text{ V}$		3.333		V
		$2\times\text{ to }1.5\times$, $V(M0) = V_{IN}$, $V(M1) = 0\text{ V}$		3.413		V
		Hysteresis, $V(M0) = V_{IN}$, $V(M1) = 0\text{ V}$		80		mV
		$1.5\times\text{ to }2\times$, $V(M0) = 0\text{ V}$, $V(M1) = V_{IN}$		3.87		V
		$2\times\text{ to }1.5\times$, $V(M0) = 0\text{ V}$, $V(M1) = V_{IN}$		3.93		V
		Hysteresis, $V(M0) = 0\text{ V}$, $V(M1) = V_{IN}$		60		mV
I_{SC}	Short-circuit output current	$V_{OUT} = 0\text{ V}$		250		mA
t_{ON}	V_{OUT} turnon time from shutdown ⁽⁵⁾			300		μs

(1) All voltages are with respect to the potential at the GND pins.

(2) Minimum and maximum limits are specified by design, test, or statistical analysis. Typical numbers are not ensured, but do represent the most likely norm.

(3) C_{IN} , C_{OUT} , C_1 , C_2 : Low-ESR Surface-Mount Ceramic Capacitors (MLCCs) used in setting electrical characteristics.

(4) There is a 450-k Ω (typical) pulldown resistor connected internally to each logic input.

(5) Turnon time is measured from when the M0 or M1 signal is pulled high until the output voltage crosses 90% of its final value.

7.6 Typical Characteristics

Unless otherwise specified: $V_{IN} = 3.6\text{ V}$, $V(M0) = 0\text{ V}$, $V(M1) = V_{IN}$, $C_1 = C_2 = 0.47\ \mu\text{F}$, $C_{IN} = C_{OUT} = 1\ \mu\text{F}$, $T_A = 25^\circ\text{C}$. Capacitors are low-ESR multi-layer ceramic capacitors (MLCC's).

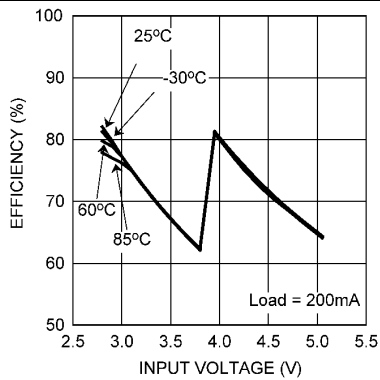

5-V Mode

Figure 1. Efficiency vs. Input Voltage

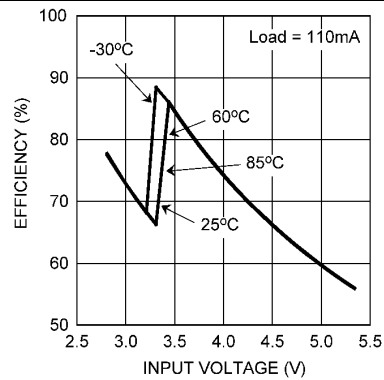

4.5-V Mode

Figure 2. Efficiency vs. Input Voltage

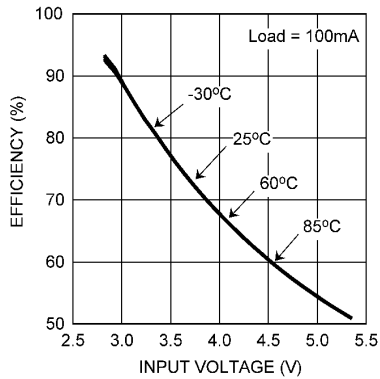

4.1-V Mode

Figure 3. Efficiency vs. Input Voltage

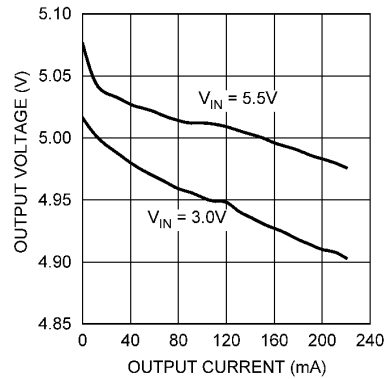

5-V Mode

Figure 4. Output Voltage vs. Output Current

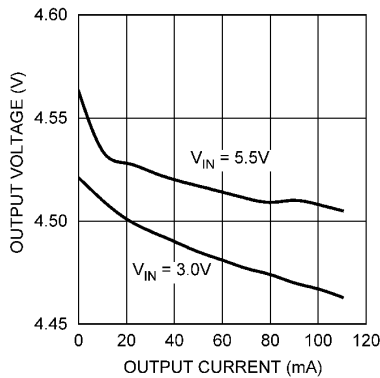

4.5-V Mode

Figure 5. Output Voltage vs. Output Current

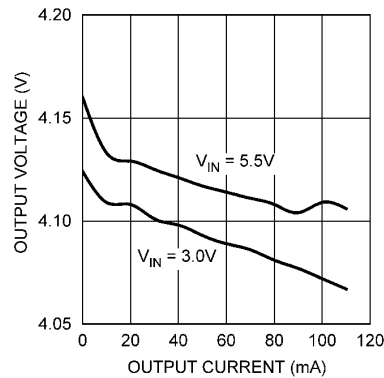

4.1-V Mode

Figure 6. Output Voltage vs. Output Current

Typical Characteristics (continued)

Unless otherwise specified: $V_{IN} = 3.6\text{ V}$, $V(M0) = 0\text{ V}$, $V(M1) = V_{IN}$, $C_1 = C_2 = 0.47\text{ }\mu\text{F}$, $C_{IN} = C_{OUT} = 1\text{ }\mu\text{F}$, $T_A = 25^\circ\text{C}$. Capacitors are low-ESR multi-layer ceramic capacitors (MLCC's).

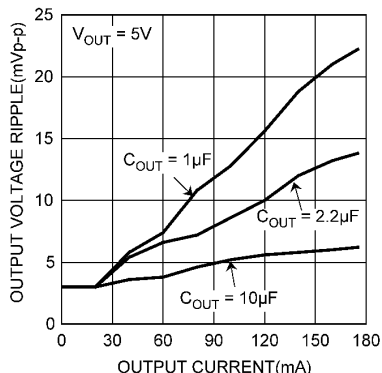

5-V Mode

Figure 7. Output Voltage Ripple vs. Output Current

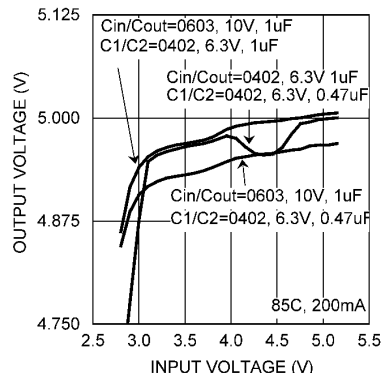

5-V Mode

Figure 8. Output Voltage vs. Input Voltage

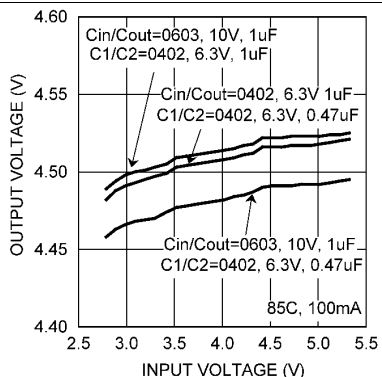

4.5-V Mode

Figure 9. Output Voltage vs. Input Voltage

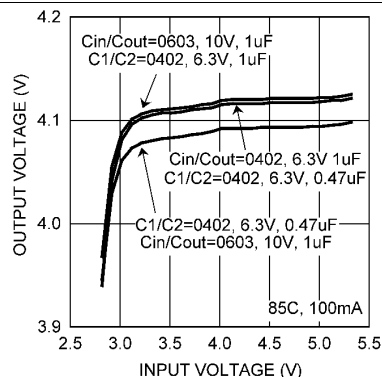

4.1-V Mode

Figure 10. Output Voltage vs. Input Voltage

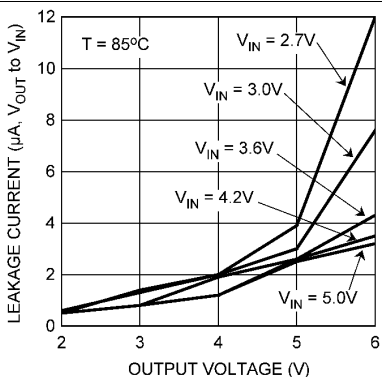

Figure 11. Output Leakage Current, Device Shutdown

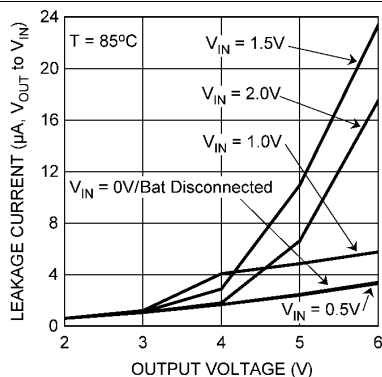

Figure 12. Output Leakage Current, Device Shutdown

Typical Characteristics (continued)

Unless otherwise specified: $V_{IN} = 3.6\text{ V}$, $V(M0) = 0\text{ V}$, $V(M1) = V_{IN}$, $C_1 = C_2 = 0.47\text{ }\mu\text{F}$, $C_{IN} = C_{OUT} = 1\text{ }\mu\text{F}$, $T_A = 25^\circ\text{C}$. Capacitors are low-ESR multi-layer ceramic capacitors (MLCC's).

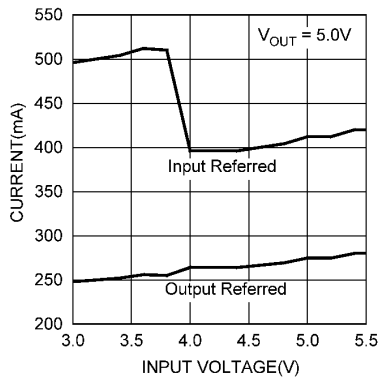

Figure 13. Current Limit vs. Input Voltage

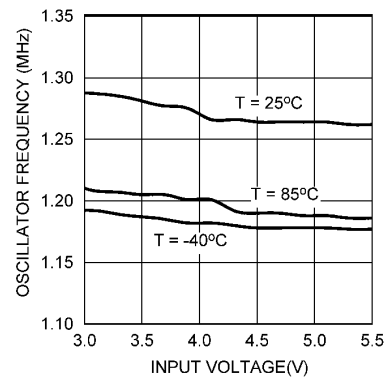

Figure 14. Oscillator Frequency vs. Input Voltage

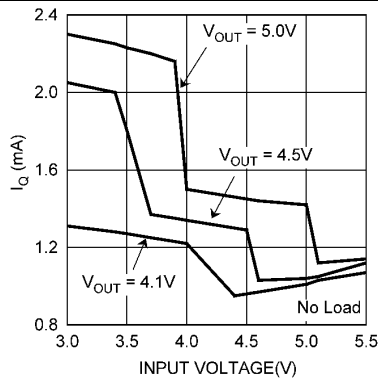

Figure 15. Operating Current vs. Input Voltage

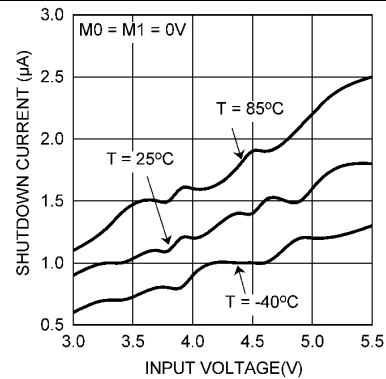
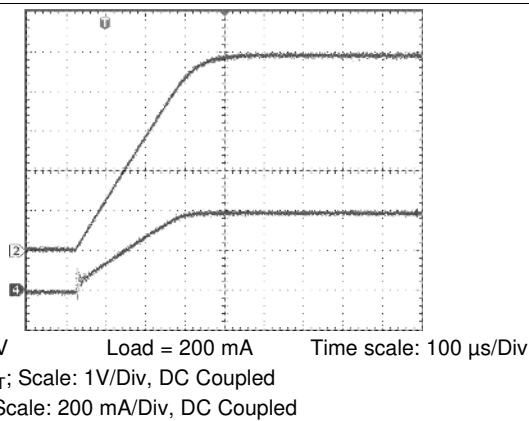
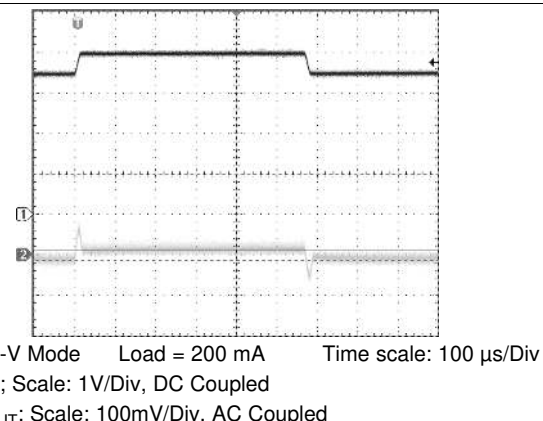

Figure 16. Shutdown Supply Current vs. Input Voltage



$V_{IN} = 3.6\text{ V}$ Load = 200 mA Time scale: 100 $\mu\text{s}/\text{Div}$
 CH2: V_{OUT} ; Scale: 1V/Div, DC Coupled
 CH4: I_{IN} ; Scale: 200 mA/Div, DC Coupled

Figure 17. Start-up Behavior, 5-V Mode



$V_{OUT} = 5\text{-V Mode}$ Load = 200 mA Time scale: 100 $\mu\text{s}/\text{Div}$
 CH1: V_{IN} ; Scale: 1V/Div, DC Coupled
 CH2: V_{OUT} ; Scale: 100mV/Div, AC Coupled

Figure 18. Line Step, 3.5 V to 4 V

Typical Characteristics (continued)

Unless otherwise specified: $V_{IN} = 3.6\text{ V}$, $V(M0) = 0\text{ V}$, $V(M1) = V_{IN}$, $C_1 = C_2 = 0.47\text{ }\mu\text{F}$, $C_{IN} = C_{OUT} = 1\text{ }\mu\text{F}$, $T_A = 25^\circ\text{C}$.
Capacitors are low-ESR multi-layer ceramic capacitors (MLCC's).

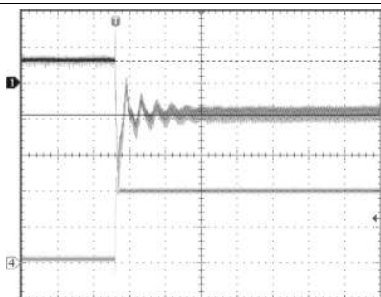

$V_{OUT} = 5\text{-V Mode}$ $V_{BATT} = 4\text{ V}$ Time scale: $10\text{ }\mu\text{s/Div}$
CH1: V_{OUT} ; Scale: 50mV/Div , AC Coupled
CH4: I_{OUT} ; Scale: 100mA/Div , DC Coupled

Figure 19. Load Step With Li-Ion Battery, 10 mA to 200 mA

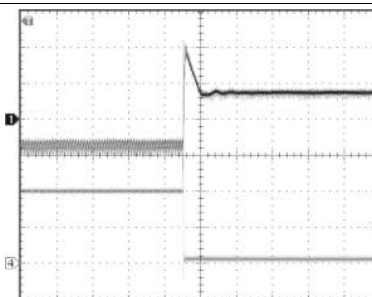

$V_{OUT} = 5\text{-V Mode}$ $V_{BATT} = 4\text{ V}$ Time scale: $10\text{ }\mu\text{s/Div}$
CH1: V_{OUT} ; Scale: 50mV/Div , AC Coupled
CH4: I_{OUT} ; Scale: 100mA/Div , DC Coupled

Figure 20. Load Step With Li-Ion Battery 200 mA to 10 mA

8 Detailed Description

8.1 Overview

The LM2757 is a switched capacitor converter that produces a regulated output voltage of either 5 V, 4.5 V or 4.1 V, depending on the mode selected. The core of the part is a highly efficient charge pump that utilizes fixed frequency pre-regulation to minimize ripple and power losses over wide input voltage and output current ranges. A description of the principal operational characteristics of the LM2757 is shown in the [Functional Block Diagram](#) and detailed in [Feature Description](#).

8.2 Functional Block Diagram

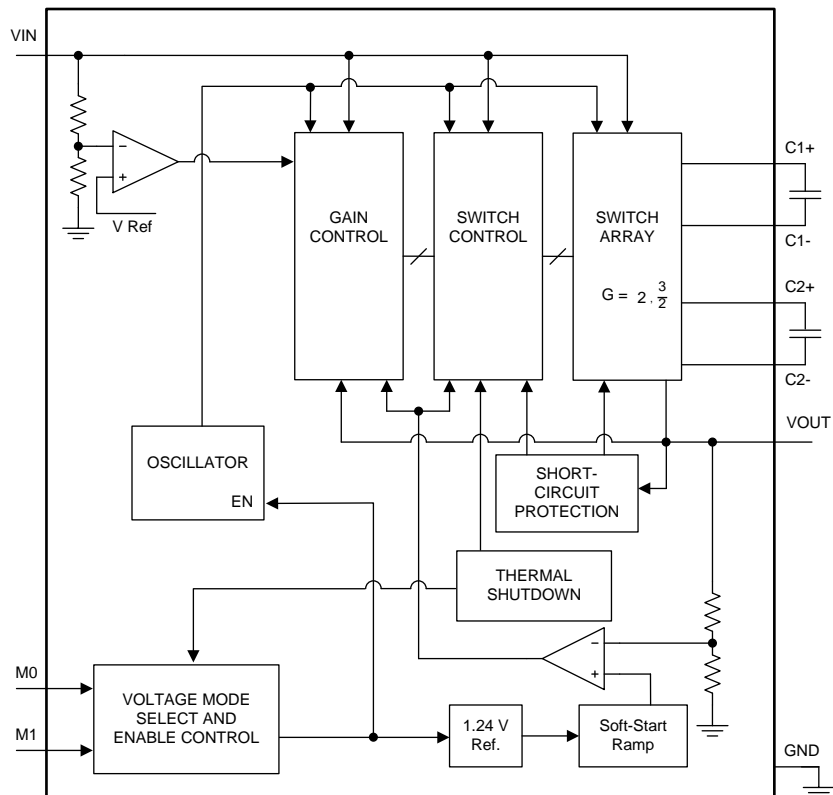

8.3 Feature Description

The core of the LM2757 is a two-phase charge pump controlled by an internally generated non-overlapping clock. The charge pump operates by using external flying capacitors C_1 and C_2 to transfer charge from the input to the output. At input voltages below 3.9 V (typical) for the 5-V mode, the LM2757 operates in a $2\times$ gain, with the input current being equal to $2\times$ the load current. At input voltages above 3.9 V (typical) for the 5-V mode, the part utilizes a gain of $3/2\times$, resulting in an input current equal to $3/2$ times the load current. For the 4.5-V mode, the LM2757 operates in a $2\times$ gain when the input voltage is below 3.35 V (typical) and transitions to a $3/2\times$ gain when the input voltage is above 3.35 V (typical). For the 4.1-V mode, the device utilizes the $3/2\times$ gain for the entire input voltage range.

The two phases of the switched capacitor switching cycle are referred to as the *phase one* and the *phase two*. During phase one, one flying capacitor is charged by the input supply while the other flying capacitor is connected to the output and delivers charge to the load. After half of the switching cycle [$t = 1/(2 \times f_{SW})$], the LM2757 switches to phase two. In this configuration, the capacitor that supplied charge to the load in phase one is connected to the input to be recharged while the capacitor that had been charged in the previous phase is connected to the output to deliver charge. With this topology, output ripple is reduced by delivering charge to the output in every phase.

Feature Description (continued)

The LM2757 uses fixed frequency pre-regulation to regulate the output voltage. The input and output connections of the flying capacitors are made with internal MOS switches. Pre-regulation limits the gate drive of the MOS switch connected between the voltage input and the flying capacitors. Controlling the on resistance of this switch limits the amount of charge transferred into and out of each flying capacitor during the charge and discharge phases, and in turn helps to keep the output ripple very low.

8.3.1 Efficiency Performance

Charge-pump efficiency is derived in [Equation 1](#) and [Equation 2](#) (supply current and other losses are neglected for simplicity):

$$I_{IN} = G \times I_{OUT} \quad (1)$$

$$E = (V_{OUT} \times I_{OUT}) \div (V_{IN} \times I_{IN}) = V_{OUT} \div (G \times V_{IN})$$

where

- G = the charge pump gain
- E = efficiency (2)

Efficiency is at its highest as $G \times V_{IN}$ approaches V_{OUT} . Refer to [Typical Characteristics](#) for detailed efficiency data. The transition between gains of 3/2 and 2 are clearly distinguished by the sharp discontinuity in the efficiency curve.

8.3.2 Soft Start

The LM2757 employs soft-start circuitry to prevent excessive input inrush currents during start-up. At start-up, the output voltage gradually rises from 0 V to the nominal output voltage. This occurs in 300 μ s (typical). Soft-start is engaged when the device is enabled.

8.3.3 Thermal Shutdown

Protection from damage related to overheating is achieved with a thermal shutdown feature. When the junction temperature rises to 145°C (typical), the device switches into shutdown mode. The LM2757 disengages thermal shutdown when the junction temperature of the part is reduced to 135°C (typical). Due to the high efficiency of the LM2757, thermal shutdown and/or thermal cycling are not encountered when the part is operated within specified input voltage, output current, and ambient temperature operating ratings. If thermal cycling is seen under these conditions, the most likely cause is an inadequate PCB layout that does not allow heat to be sufficiently dissipated out of the device.

8.3.4 Current-Limit Protection

The LM2757 charge pump contains current-limit protection circuitry that protects the device during V_{OUT} fault conditions where excessive current is drawn. Output current is limited to 250 mA (typical).

8.4 Device Functional Modes

8.4.1 Enable and Voltage Mode Selection

The LM2757 is enabled when either one of the mode select pins (M0, M1) has a logic High voltage applied to it. There are 450-k Ω pulldown resistors connected internally to each of the mode select pins. The voltage mode is selected according to [Table 1](#).

Device Functional Modes (continued)

8.4.2 Shutdown With Output High Impedance

The LM2757 is in shutdown mode when there is a logic Low voltage on both mode select pins (M0, M1). There are also 450-k Ω pulldown resistors connected to both mode select pins, pulling the nodes down to ground when there is no signal present. When in shutdown, the output of the LM2757 is high impedance, allowing an external supply to drive the output line such as in USB OTG or mobile HDMI applications. Refer to the output leakage current graphs in [Typical Characteristics](#) for typical leakage currents into the VOUT pin, when driven by a separate supply during shutdown. Output leakage increases with temperature, with the lowest leakage occurring at -30°C and the highest leakage at 85°C (on which the graph is based). It should be noted when looking at the graphs as the input voltage falls the leakage peaks at around an input voltage of 1.5 V, then goes down as the input voltage decrease to 0 V. The leakage at an input voltage of 0 V is the same as the leakage current when the battery is disconnected from the circuit.

9 Application and Implementation

NOTE

Information in the following applications sections is not part of the TI component specification, and TI does not warrant its accuracy or completeness. TI's customers are responsible for determining suitability of components for their purposes. Customers should validate and test their design implementation to confirm system functionality.

9.1 Application Information

The LM2757 can create a 4.1-V, 4.5-V or 5-V system rail capable of delivering up to 180 mA of output current to the load. The 1.242-MHz switched capacitor boost allows for the use of small value discrete external components.

9.2 Typical Application

9.2.1 Switched-Capacitor Boost Regulator

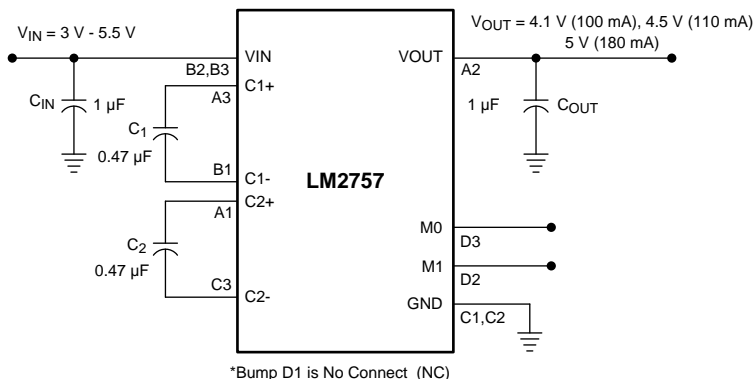

Figure 21. LM2757 Typical Application

9.2.1.1 Design Requirements

Example requirements for typical switched-capacitor boost regulator applications:

Table 2. Design Parameters

DESIGN PARAMETER	EXAMPLE VALUE
Input voltage range	2.7 V to 5.5 V
Output current	0 to 180 mA
Boost switching frequency	1.242 MHz

9.2.1.2 Detailed Design Procedure

9.2.1.2.1 Recommended Capacitor Types

The LM2757 requires 4 external capacitors for proper operation. Surface-mount multi-layer ceramic capacitors are recommended. These capacitors are small, inexpensive and have very low equivalent series resistance (ESR, $\leq 15 \text{ m}\Omega$ typical). Tantalum capacitors, OS-CON capacitors, and aluminum electrolytic capacitors generally are not recommended for use with the LM2757 due to their high ESR, as compared to ceramic capacitors.

For most applications, ceramic capacitors with an X7R or X5R temperature characteristic are preferred for use with the LM2757. These capacitors have tight capacitance tolerance (as good as $\pm 10\%$) and hold their value over temperature (X7R: $\pm 15\%$ over -55°C to 125°C ; X5R: $\pm 15\%$ over -55°C to 85°C).

Capacitors with a Y5V or Z5U temperature characteristic are generally not recommended for use with the LM2757. These types of capacitors typically have wide capacitance tolerance (80%, –20%) and vary significantly over temperature (Y5V: +22%, –82% over –30°C to +85°C range; Z5U: 22%, –56% over a 10°C to 85°C range). Under some conditions, a 1- μ F-rated Y5V or Z5U capacitor could have a capacitance as low as 0.1 μ F. Such detrimental deviation is likely to cause Y5V and Z5U capacitors to fail to meet the minimum capacitance requirements of the LM2757.

Net capacitance of a ceramic capacitor decreases with increased DC bias. This degradation can result in lower capacitance than expected on the input and/or output, resulting in higher ripple voltages and currents. Using capacitors at DC bias voltages significantly below the capacitor voltage rating usually minimizes DC bias effects. Consult capacitor manufacturers for information on capacitor DC bias characteristics.

Capacitance characteristics can vary quite dramatically with different application conditions, capacitor types, and capacitor manufacturers. It is strongly recommended that the LM2757 circuit be thoroughly evaluated early in the design-in process with the mass-production capacitors of choice. This helps ensure that any such variability in capacitance does not negatively impact circuit performance.

The voltage rating of the output capacitor should be 10 V or more. For example, a 10-V 0603 1- μ F capacitor is acceptable for use with the LM2757, as long as the capacitance does not fall below a minimum of 0.5 μ F in the intended application. All other capacitors should have a voltage rating at or above the maximum input voltage of the application. The capacitors should be selected such that the capacitance on the input does not fall below 0.7 μ F, and the capacitance of the flying capacitors does not fall below 0.2 μ F.

Table 3 lists some leading ceramic capacitor manufacturers.

Table 3. Manufacturers of Suggested Capacitors

MANUFACTURER	CONTACT INFORMATION
AVX	www.avx.com
Murata	www.murata.com
Taiyo-Yuden	www.t-yuden.com
TDK	www.component.tdk.com
Vishay-Vitramon	www.vishay.com

9.2.1.2.2 Output Capacitor And Output Voltage Ripple

The output capacitor in the LM2757 circuit (C_{OUT}) directly impacts the magnitude of output voltage ripple. Other prominent factors also affecting output voltage ripple include input voltage, output current, and flying capacitance. Due to the complexity of the regulation topology, providing equations or models to approximate the magnitude of the ripple can not be easily accomplished. But one important generalization can be made: increasing (decreasing) the output capacitance results in a proportional decrease (increase) in output voltage ripple.

In typical high-current applications, a 1- μ F low-ESR ceramic output capacitor is recommended. Different output capacitance values can be used to reduce ripple, shrink the solution size, and/or cut the cost of the solution. But changing the output capacitor may also require changing the flying capacitor and/or input capacitor to maintain good overall circuit performance. Performance of the LM2757 with different capacitor setups is discussed in [Recommended Capacitance](#).

High ESR in the output capacitor increases output voltage ripple. If a ceramic capacitor is used at the output, this is usually not a concern because the ESR of a ceramic capacitor is typically very low and has only a minimal impact on ripple magnitudes. If a different capacitor type with higher ESR is used (tantalum, for example), the ESR could result in high ripple. To eliminate this effect, the net output ESR can be significantly reduced by placing a low-ESR ceramic capacitor in parallel with the primary output capacitor. The low ESR of the ceramic capacitor is in parallel with the higher ESR, resulting in a low net ESR based on the principles of parallel resistance reduction.

9.2.1.2.3 Input Capacitor And Input Voltage Ripple

The input capacitor (C_{IN}) is a reservoir of charge that aids a quick transfer of charge from the supply to the flying capacitors during the charge phase of operation. The input capacitor helps to keep the input voltage from drooping at the start of the charge phase when the flying capacitors are connected to the input. It also filters noise on the input pin, keeping this noise out of sensitive internal analog circuitry that is biased off the input line.

Much like the relationship between the output capacitance and output voltage ripple, input capacitance has a dominant and first-order effect on input ripple magnitude. Increasing (decreasing) the input capacitance results in a proportional decrease (increase) in input voltage ripple. Input voltage, output current, and flying capacitance also affects input ripple levels to some degree.

In typical high-current applications, a 1- μ F low-ESR ceramic capacitor is recommended on the input. Different input capacitance values can be used to reduce ripple, shrink the solution size, and/or cut the cost of the solution. But changing the input capacitor may also require changing the flying capacitor and/or output capacitor to maintain good overall circuit performance. Performance of the LM2757 with different capacitor setups is discussed in [Recommended Capacitance](#).

9.2.1.2.4 Flying Capacitors

The flying capacitors (C_1 , C_2) transfer charge from the input to the output. Flying capacitance can impact both output current capability and ripple magnitudes. If flying capacitance is too small, the LM2757 may not be able to regulate the output voltage when load currents are high. On the other hand, if the flying capacitance is too large, the flying capacitor might overwhelm the input and output capacitors, resulting in increased input and output ripple.

In typical high-current applications, 0.47- μ F low-ESR ceramic capacitors are recommended for the flying capacitors. Polarized capacitors (tantalum, aluminum electrolytic, etc.) must not be used for the flying capacitor, as they could become reverse-biased during LM2757 operation.

9.2.1.2.5 Recommended Capacitance

The data in [Table 4](#) can be used to assist in the selection of capacitance for each node that best balances solution size and cost with the electrical requirements of the application.

As previously discussed, input and output ripple voltages varies with output current and input voltage. The numbers provided show expected ripple voltage with $V_{IN} = 3.6$ V and a load current of 200 mA at 5-V output, 100 mA at 4.5-V output, and 100 mA at 4.1-V output. [Table 4](#) offers a first look at approximate ripple levels and provides a comparison of different capacitance configurations, but is not intended to ensure performance. With any capacitance configuration chosen, always verify that the performance of the ripple waveforms are suitable for the intended application. The same capacitance value must be used for all the flying capacitors. For output regulation performance with different capacitor configurations, please refer to the output voltage vs. input voltage graphs in [Typical Characteristics](#). The output voltage regulation is typically better when using capacitors with a higher capacitance value and a higher voltage bias rating than the nominal voltage applied to them, as can be seen in the graphs, but this may have an impact in capacitor case size. For typical high-current small solution size applications, 1- μ F capacitance X5R temperature characteristic rating 0402 (C1005) case size and 10-V bias or higher capacitors can be used for the input, output and flying capacitors. According to current capacitor offerings, there are no capacitors in the 0201 (C0603) case size that satisfy the minimum capacitance requirements of the LM2757 circuit. When selecting capacitors, those with the highest voltage bias rating available from the capacitor supplier are preferred.

Table 4. LM2757 Performance With Different Capacitor Configurations⁽¹⁾

CAPACITOR CONFIGURATION ($V_{IN} = 3.6$ V)	5-V, 200-mA OUTPUT RIPPLE (mV)(typical)	4.5-V, 100-mA OUTPUT RIPPLE (mV) (typical)	4.1-V, 100-mA OUTPUT RIPPLE (mV)(typical)
$C_{IN} = 1 \mu\text{F}$, $C_{OUT} = 1 \mu\text{F}$, C_1 and $C_2 = 0.47 \mu\text{F}$	32	12	11
$C_{IN} = 0.68 \mu\text{F}$, $C_{OUT} = 1 \mu\text{F}$, C_1 and $C_2 = 0.47 \mu\text{F}$	32	11	11
$C_{IN} = 0.68 \mu\text{F}$, $C_{OUT} = 0.47 \mu\text{F}$, C_1 and $C_2 = 0.47 \mu\text{F}$	51	151	15
$C_{IN} = 0.68 \mu\text{F}$, $C_{OUT} = 0.47 \mu\text{F}$, C_1 and $C_2 = 0.22 \mu\text{F}$	53	181	18

(1) Refer to the text in [Recommended Capacitance](#) for detailed information on the data in this table.

9.2.1.3 Application Curves

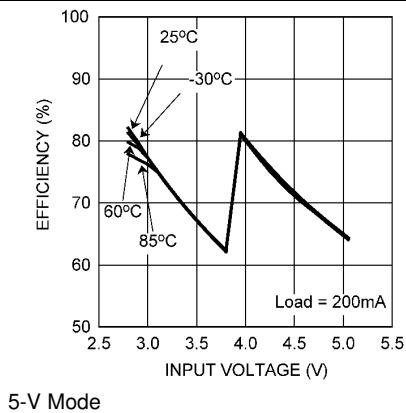

Figure 22. Efficiency vs. Input Voltage

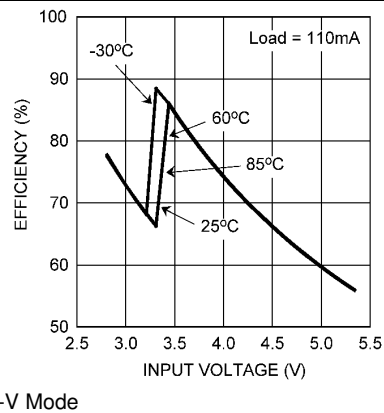

Figure 23. Efficiency vs. Input Voltage

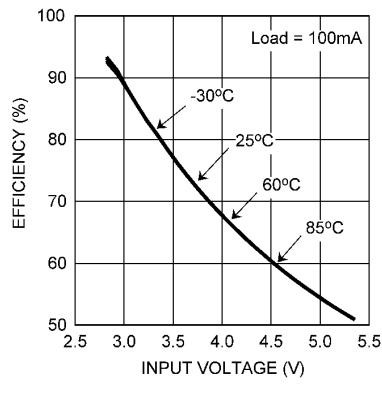

Figure 24. Efficiency vs. Input Voltage

9.2.2 USB OTG / Mobile HDMI Power Supply

The 5-V output mode is normally used for the USB OTG / Mobile HDMI application. Therefore, the LM2757 can be enabled or disabled by applying a logic signal on only the M1 pin while grounding the M0 pin. Depending on the USB/HDMI mode of the application, the LM2757 can be enabled to drive the power bus line (Host), or disabled to put its output in high impedance allowing an external supply to drive the bus line (Slave). In addition to the high-impedance backdrive protection, the output current limit protection is 250 mA (typical), well within the USB OTG and HDMI requirements.

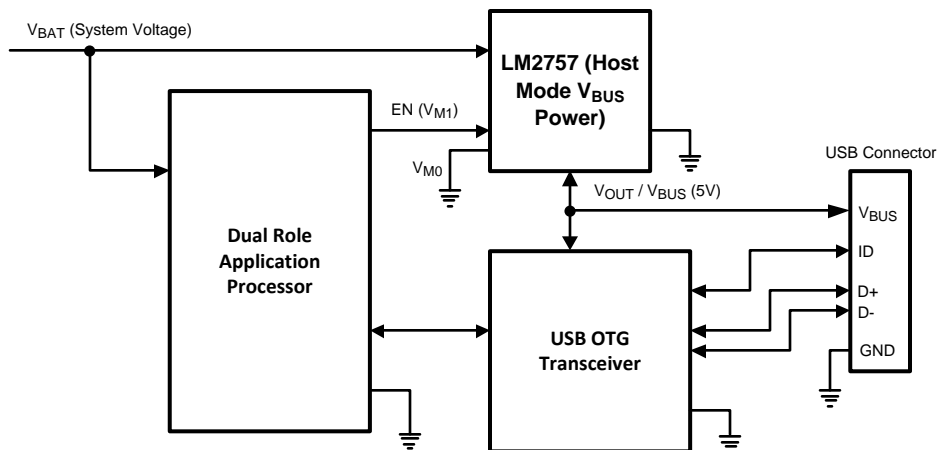

Figure 25. USB OTG / Mobile HDMI

9.2.3 Supercapacitor Flash Driver

Using the 5-V output voltage mode, the LM2757 can charge a supercapacitor for LED flash applications while limiting the peak current drawn off the battery during the charge cycle. The LM2757 can be disabled for the Flash event, placing its output in high impedance with the input. In this way, all charge for the flash LED(s) comes directly off the supercapacitor and does not load the main battery line. The LM2757 can be enabled or disabled by applying a logic signal on only the M1 pin while grounding the M0 pin.

Special consideration must be given when using supercapacitors for LED flash applications where the voltage on the capacitor is charged to a fixed value. This is due to the possible power management issues that can arise as a result of the high flash current and wide tolerance ranges ($V-I$ characteristics) of typical flash LEDs. If the voltage across the Flash LED(s) is not managed, damage may occur where a relatively low V_f LED is overdriven or places excessive voltage across the bottom control FET. To help avoid this issue, the use of a high-power current sink is advised in applications where the forward voltage specification of the flash LED has a wide range.

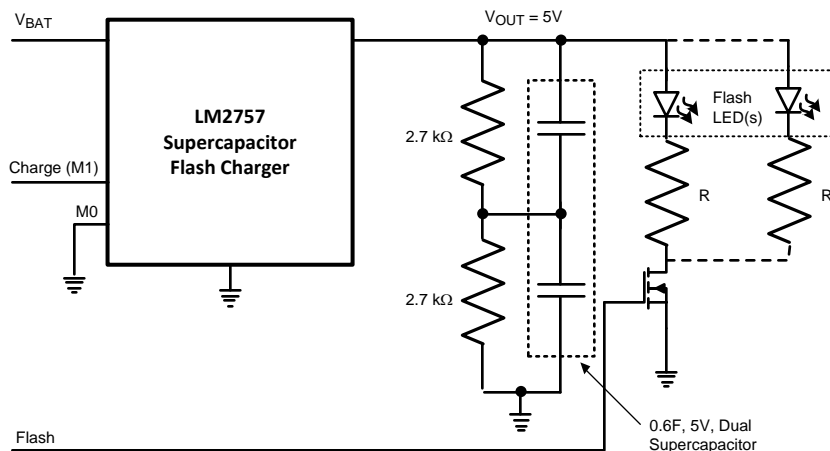

Figure 26. Supercapacitor Flash Driver

9.2.4 LED Driver

The 5-V, 4.5-V, or the 4.1-V mode can be used depending on the forward voltage and load requirements of the LED application. The LM2757 can be enabled or disabled by applying the appropriate combination of logic signals on the M1 and M0 pins. LED current for each string in this application is limited by the voltage across the string's ballast resistor, which is dependent on the output voltage mode selected and the V-I profile of each LED used.

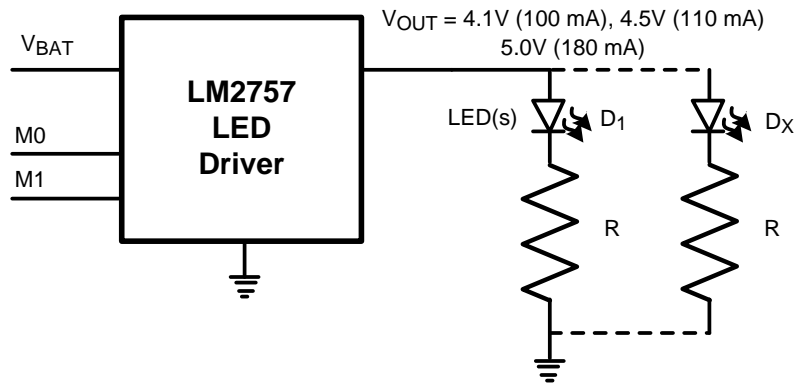

Figure 27. LED Driver

10 Power Supply Recommendations

The LM2757 is designed to operate as an inverter over an input voltage supply range between 2.7 V and 5.5 V.

11 Layout

11.1 Layout Guidelines

Proper board layout helps to ensure optimal performance of the LM2757 circuit. The following guidelines are recommended:

- Place capacitors as close to the LM2757 as possible, and preferably on the same side of the board as the device.
- Use short, wide traces to connect the external capacitors to the LM2757 to minimize trace resistance and inductance.
- Use a low resistance connection between ground and the GND pin of the LM2757. Using wide traces and/or multiple vias to connect GND to a ground plane on the board is most advantageous.

11.2 Layout Example

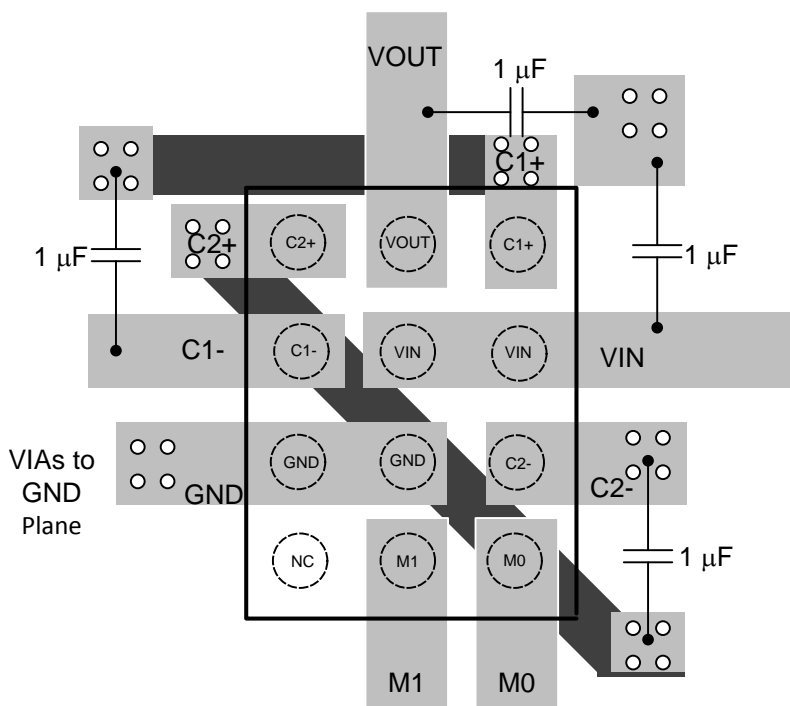

Figure 28. LM2757 Layout Example

12 Device and Documentation Support

12.1 Device Support

12.1.1 Third-Party Products Disclaimer

TI'S PUBLICATION OF INFORMATION REGARDING THIRD-PARTY PRODUCTS OR SERVICES DOES NOT CONSTITUTE AN ENDORSEMENT REGARDING THE SUITABILITY OF SUCH PRODUCTS OR SERVICES OR A WARRANTY, REPRESENTATION OR ENDORSEMENT OF SUCH PRODUCTS OR SERVICES, EITHER ALONE OR IN COMBINATION WITH ANY TI PRODUCT OR SERVICE.

12.2 Documentation Support

12.2.1 Related Documentation

For related documentation see the following:

Texas Instruments Application Note 1112 *DSBGA Wafer Level Chip Scale Package* ([SNVA009](#)).

12.3 Community Resources

The following links connect to TI community resources. Linked contents are provided "AS IS" by the respective contributors. They do not constitute TI specifications and do not necessarily reflect TI's views; see TI's [Terms of Use](#).

TI E2E™ Online Community *TI's Engineer-to-Engineer (E2E) Community*. Created to foster collaboration among engineers. At [e2e.ti.com](#), you can ask questions, share knowledge, explore ideas and help solve problems with fellow engineers.

Design Support *TI's Design Support* Quickly find helpful E2E forums along with design support tools and contact information for technical support.

12.4 Trademarks

E2E is a trademark of Texas Instruments.
All other trademarks are the property of their respective owners.

12.5 Electrostatic Discharge Caution



This integrated circuit can be damaged by ESD. Texas Instruments recommends that all integrated circuits be handled with appropriate precautions. Failure to observe proper handling and installation procedures can cause damage.

ESD damage can range from subtle performance degradation to complete device failure. Precision integrated circuits may be more susceptible to damage because very small parametric changes could cause the device not to meet its published specifications.

12.6 Glossary

[SLYZ022](#) — *TI Glossary*.

This glossary lists and explains terms, acronyms, and definitions.

13 Mechanical, Packaging, and Orderable Information

The following pages include mechanical, packaging, and orderable information. This information is the most current data available for the designated devices. This data is subject to change without notice and revision of this document. For browser-based versions of this data sheet, refer to the left-hand navigation.

PACKAGING INFORMATION

Orderable Device	Status (1)	Package Type	Package Drawing	Pins	Package Qty	Eco Plan (2)	Lead finish/ Ball material (6)	MSL Peak Temp (3)	Op Temp (°C)	Device Marking (4/5)	Samples
LM2757TM/NOPB	ACTIVE	DSBGA	YFQ	12	250	RoHS & Green	SNAGCU	Level-1-260C-UNLIM	-30 to 85	DL	Samples
LM2757TMX/NOPB	ACTIVE	DSBGA	YFQ	12	3000	RoHS & Green	SNAGCU	Level-1-260C-UNLIM	-30 to 85	DL	Samples

(1) The marketing status values are defined as follows:

ACTIVE: Product device recommended for new designs.

LIFEBUY: TI has announced that the device will be discontinued, and a lifetime-buy period is in effect.

NRND: Not recommended for new designs. Device is in production to support existing customers, but TI does not recommend using this part in a new design.

PREVIEW: Device has been announced but is not in production. Samples may or may not be available.

OBSOLETE: TI has discontinued the production of the device.

(2) **RoHS:** TI defines "RoHS" to mean semiconductor products that are compliant with the current EU RoHS requirements for all 10 RoHS substances, including the requirement that RoHS substance do not exceed 0.1% by weight in homogeneous materials. Where designed to be soldered at high temperatures, "RoHS" products are suitable for use in specified lead-free processes. TI may reference these types of products as "Pb-Free".

RoHS Exempt: TI defines "RoHS Exempt" to mean products that contain lead but are compliant with EU RoHS pursuant to a specific EU RoHS exemption.

Green: TI defines "Green" to mean the content of Chlorine (Cl) and Bromine (Br) based flame retardants meet JS709B low halogen requirements of <=1000ppm threshold. Antimony trioxide based flame retardants must also meet the <=1000ppm threshold requirement.

(3) MSL, Peak Temp. - The Moisture Sensitivity Level rating according to the JEDEC industry standard classifications, and peak solder temperature.

(4) There may be additional marking, which relates to the logo, the lot trace code information, or the environmental category on the device.

(5) Multiple Device Markings will be inside parentheses. Only one Device Marking contained in parentheses and separated by a "~" will appear on a device. If a line is indented then it is a continuation of the previous line and the two combined represent the entire Device Marking for that device.

(6) Lead finish/Ball material - Orderable Devices may have multiple material finish options. Finish options are separated by a vertical ruled line. Lead finish/Ball material values may wrap to two lines if the finish value exceeds the maximum column width.

Important Information and Disclaimer:The information provided on this page represents TI's knowledge and belief as of the date that it is provided. TI bases its knowledge and belief on information provided by third parties, and makes no representation or warranty as to the accuracy of such information. Efforts are underway to better integrate information from third parties. TI has taken and continues to take reasonable steps to provide representative and accurate information but may not have conducted destructive testing or chemical analysis on incoming materials and chemicals. TI and TI suppliers consider certain information to be proprietary, and thus CAS numbers and other limited information may not be available for release.

In no event shall TI's liability arising out of such information exceed the total purchase price of the TI part(s) at issue in this document sold by TI to Customer on an annual basis.

TAPE AND REEL INFORMATION

QUADRANT ASSIGNMENTS FOR PIN 1 ORIENTATION IN TAPE

*All dimensions are nominal

Device	Package Type	Package Drawing	Pins	SPQ	Reel Diameter (mm)	Reel Width W1 (mm)	A0 (mm)	B0 (mm)	K0 (mm)	P1 (mm)	W (mm)	Pin1 Quadrant
LM2757TM/NOPB	DSBGA	YFQ	12	250	178.0	8.4	1.35	1.75	0.76	4.0	8.0	Q1
LM2757TMX/NOPB	DSBGA	YFQ	12	3000	178.0	8.4	1.35	1.75	0.76	4.0	8.0	Q1

TAPE AND REEL BOX DIMENSIONS

*All dimensions are nominal

Device	Package Type	Package Drawing	Pins	SPQ	Length (mm)	Width (mm)	Height (mm)
LM2757TM/NOPB	DSBGA	YFQ	12	250	210.0	185.0	35.0
LM2757TMX/NOPB	DSBGA	YFQ	12	3000	210.0	185.0	35.0

YFQ0012

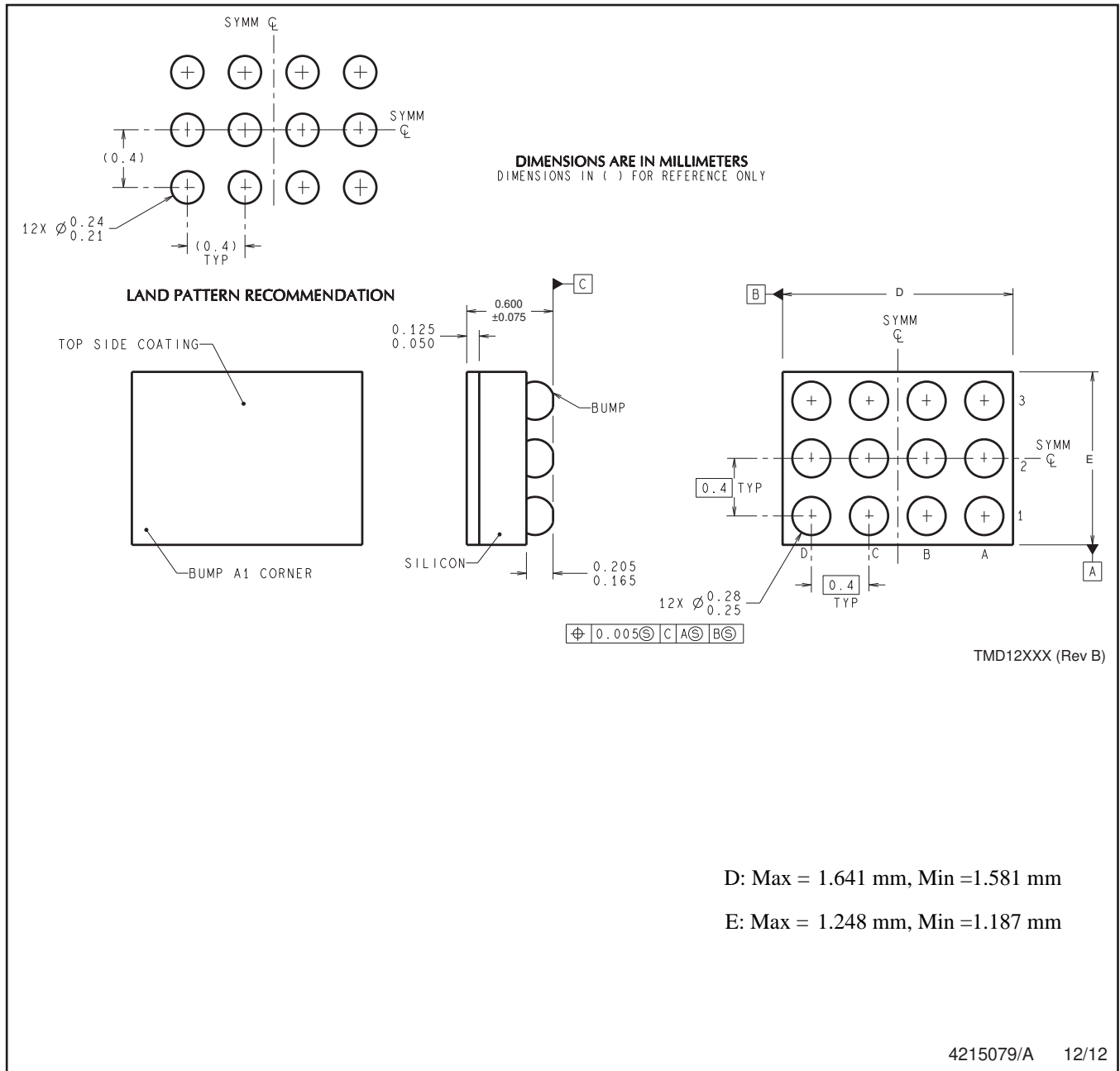

D: Max = 1.641 mm, Min = 1.581 mm

E: Max = 1.248 mm, Min = 1.187 mm

NOTES: A. All linear dimensions are in millimeters. Dimensioning and tolerancing per ASME Y14.5M-1994.
B. This drawing is subject to change without notice.

IMPORTANT NOTICE AND DISCLAIMER

TI PROVIDES TECHNICAL AND RELIABILITY DATA (INCLUDING DATA SHEETS), DESIGN RESOURCES (INCLUDING REFERENCE DESIGNS), APPLICATION OR OTHER DESIGN ADVICE, WEB TOOLS, SAFETY INFORMATION, AND OTHER RESOURCES "AS IS" AND WITH ALL FAULTS, AND DISCLAIMS ALL WARRANTIES, EXPRESS AND IMPLIED, INCLUDING WITHOUT LIMITATION ANY IMPLIED WARRANTIES OF MERCHANTABILITY, FITNESS FOR A PARTICULAR PURPOSE OR NON-INFRINGEMENT OF THIRD PARTY INTELLECTUAL PROPERTY RIGHTS.

These resources are intended for skilled developers designing with TI products. You are solely responsible for (1) selecting the appropriate TI products for your application, (2) designing, validating and testing your application, and (3) ensuring your application meets applicable standards, and any other safety, security, regulatory or other requirements.

These resources are subject to change without notice. TI grants you permission to use these resources only for development of an application that uses the TI products described in the resource. Other reproduction and display of these resources is prohibited. No license is granted to any other TI intellectual property right or to any third party intellectual property right. TI disclaims responsibility for, and you will fully indemnify TI and its representatives against, any claims, damages, costs, losses, and liabilities arising out of your use of these resources.

TI's products are provided subject to [TI's Terms of Sale](#) or other applicable terms available either on [ti.com](https://www.ti.com) or provided in conjunction with such TI products. TI's provision of these resources does not expand or otherwise alter TI's applicable warranties or warranty disclaimers for TI products.

TI objects to and rejects any additional or different terms you may have proposed.

Mailing Address: Texas Instruments, Post Office Box 655303, Dallas, Texas 75265
Copyright © 2023, Texas Instruments Incorporated