

THIS DRAWING IS UNPUBLISHED. RELEASED FOR PUBLICATION  
 © COPYRIGHT - A ALL RIGHTS RESERVED.

REVISIONS				
P	LTR	DESCRIPTION	DATE	APVD
E		REVISED PER ECO-18-001882	13FEB2018	AP DG

NOTE:

- MATERIAL:  
 HOUSING: PBT WITH 20% GF UL 94 V-0, BLACK COLOR  
 CONTACTS: PHOSPHOR BRONZE.  
 SHELL: STEEL.  
 SCREW: BRASS.  
 SCREW LOCK: BRASS.  
 SCREW TORQUE: 5kgf-cm MAX.
- FINISH:  
 CONTACTS: GOLD PLATED ON CONTACT AREA,  
 0.375µm [15µ"] MIN. MATTE TIN ON SOLDER TAIL  
 2.54µm [100µ"], WITH ENTIRE CONTACT  
 UNDERPLATED 1.27µm [50µ"] MIN. NICKEL.  
 FRONT SHELL: 2.54µm [100µ"] MIN. NICKEL PLATED.  
 REAR SHELL: 1.27µm [50µ"] MIN NICKEL UNDERPLATE.  
 2.54µm [100µ"] MIN BRIGHT TIN PLATE  
 SCREW LOCK: 1.27µm [50µ"] MIN. NICKEL PLATED.  
 BOARDLOCK: 1.27µm [50µ"] MIN NICKEL UNDERPLATE  
 1.27µm [50µ"] MIN MATTE TIN PLATE.
- WAVE SOLDER CAPABLE TO 265°C PER TE TEST SPEC.  
 109-202, CONDITION B.

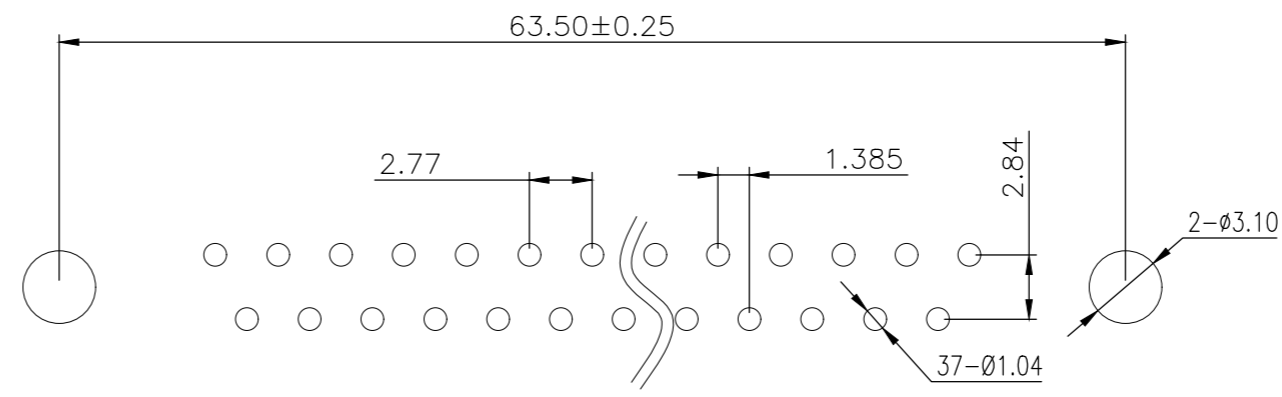
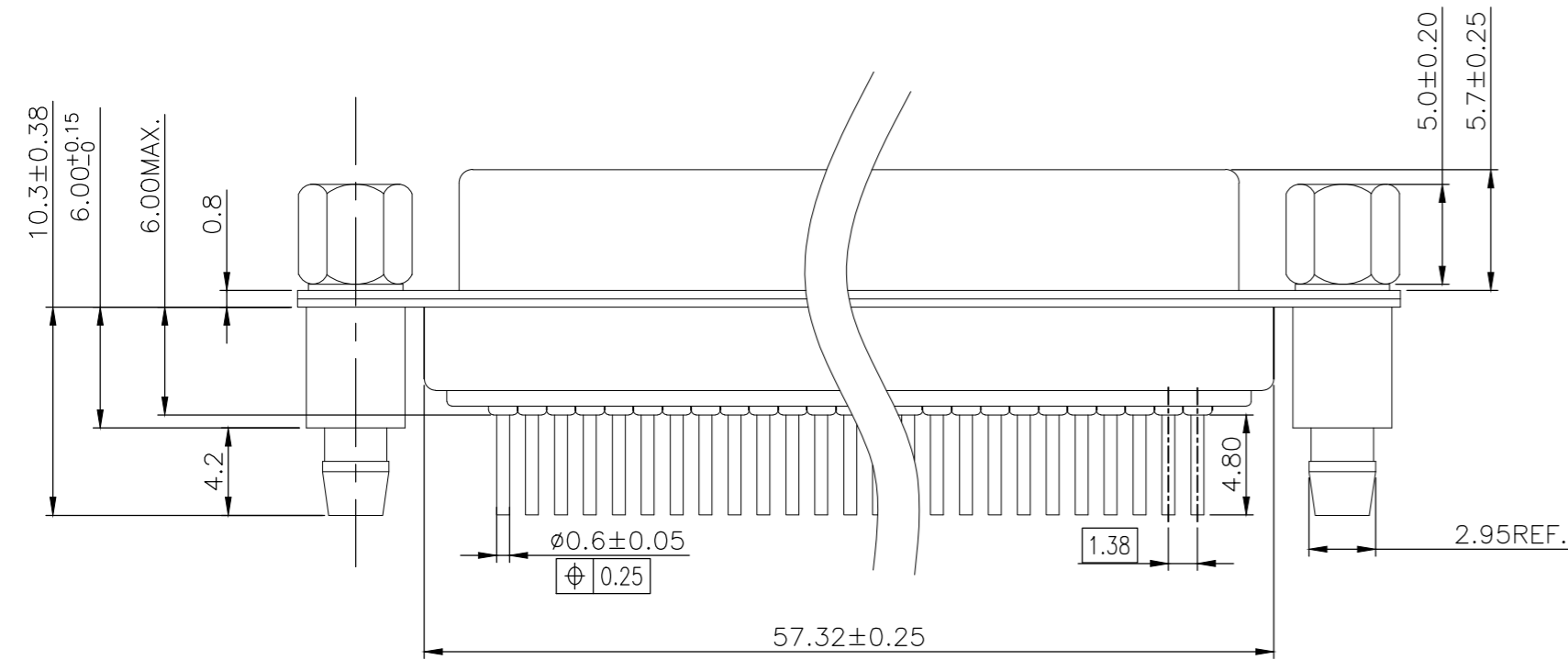
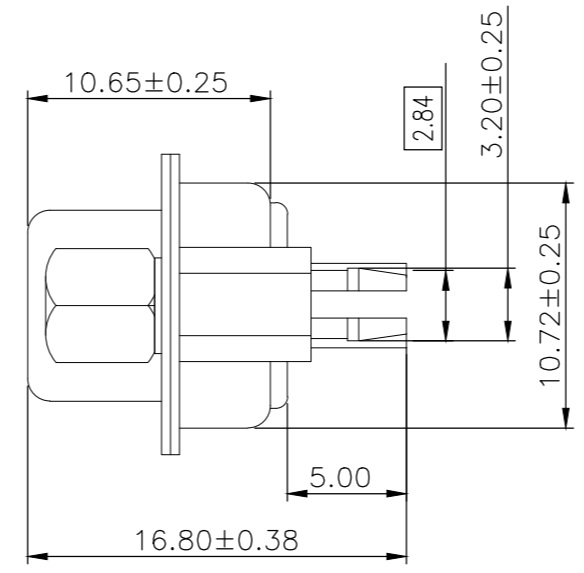
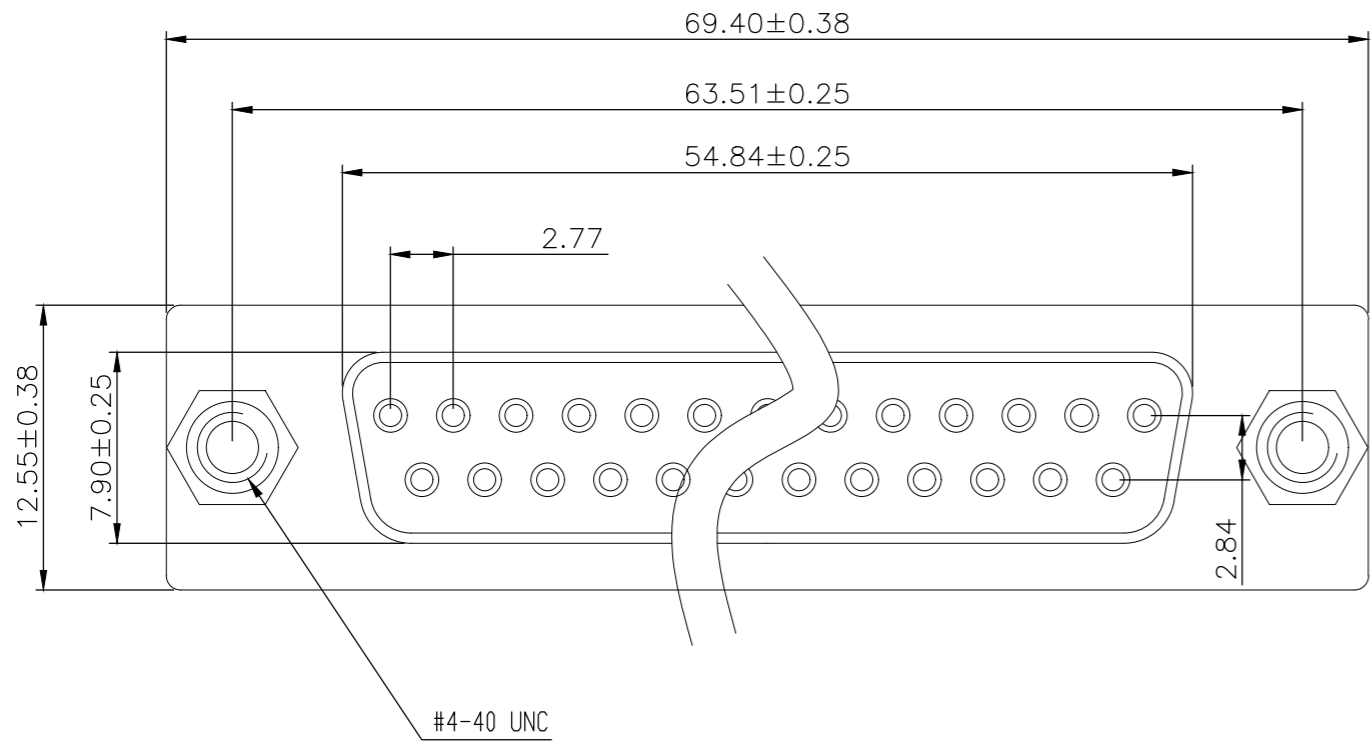

RECOMMENDED PCB LAYOUT

THIS DRAWING IS A CONTROLLED DOCUMENT.		DWN	AJITH PAI	07FEB2017
DIMENSIONS:		CHK	DAN GORENC	07FEB2017
mm	TOLERANCES UNLESS OTHERWISE SPECIFIED:	APVD	-	07FEB2017
	0 PLC	±	-	PRODUCT SPEC
	1 PLC	±	0.25	108-130013
	2 PLC	±	0.15	APPLICATION SPEC
	3 PLC	±	0.10	-
MATERIAL	FINISH	WEIGHT	0	CUSTOMER DRAWING
-	-	SCALE	3:1	SHEET 1 of 3

37w D skt W B/L & 4-40 s/lock 15u" gold		2301842-1	
DESCRIPTION		TE PART NO	
<b>TE</b> TE Connectivity			
NAME D-SUB HD20 VERTICAL 37P SKT CONNECTOR			
SIZE	CAGE CODE	DRAWING NO	RESTRICTED TO
A2	00779	C=2301842	-
SCALE		SHEET	REV
3:1		1 of 3	E

4

3

2

1

THIS DRAWING IS UNPUBLISHED. RELEASED FOR PUBLICATION  
 © COPYRIGHT - By - ALL RIGHTS RESERVED.

REVISIONS					
P	LTR	DESCRIPTION	DATE	DWN	APVD
-	-	SEE SHEET 1	-	-	-

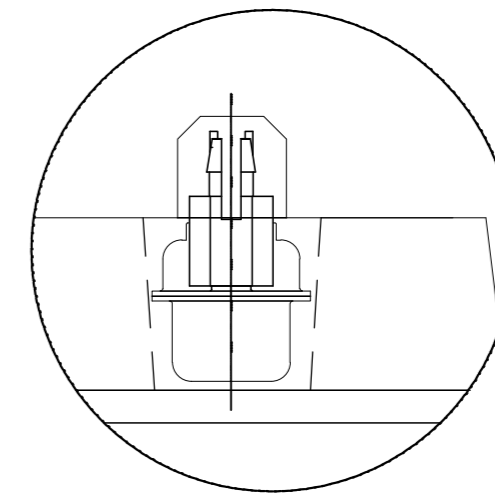
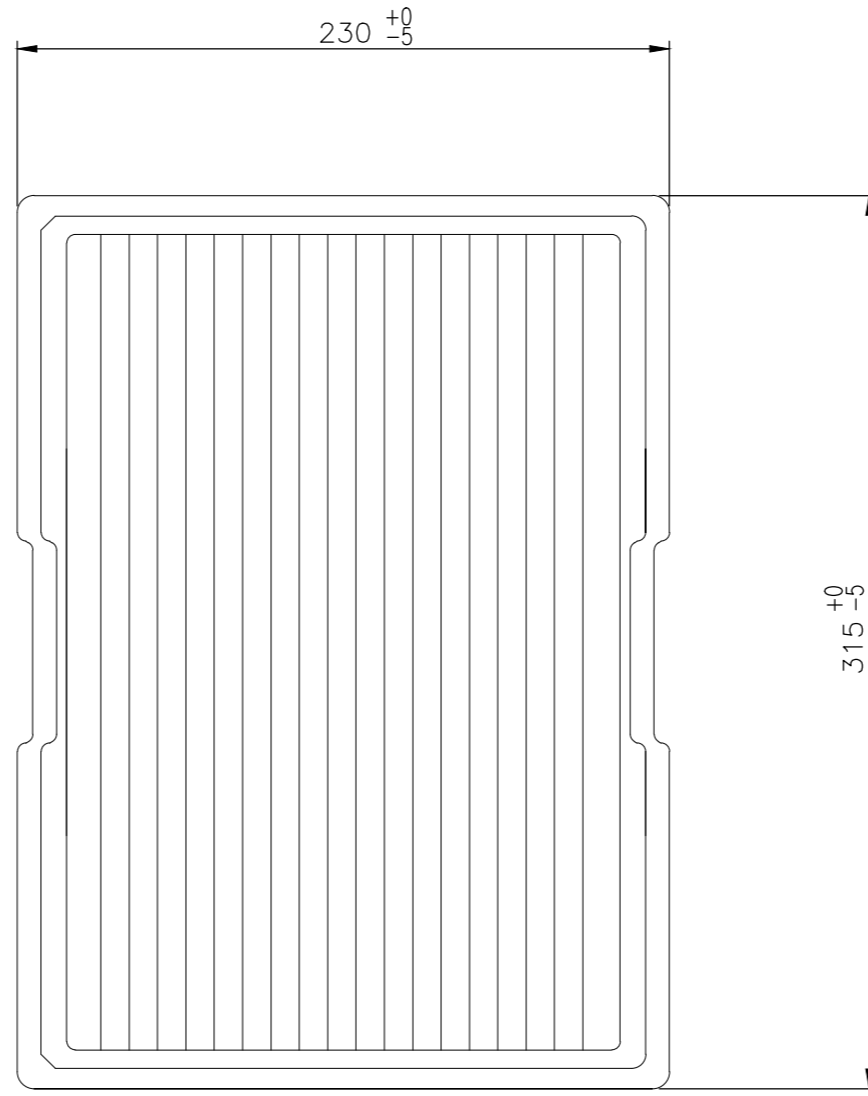
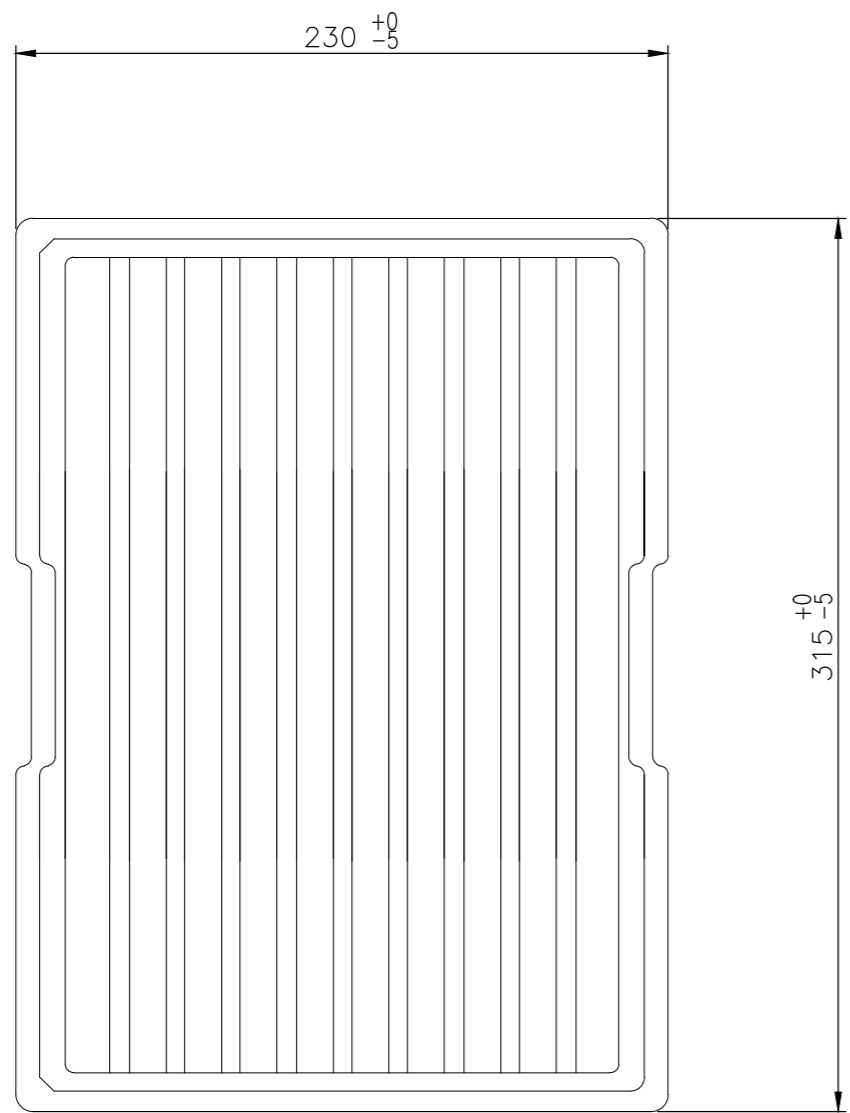
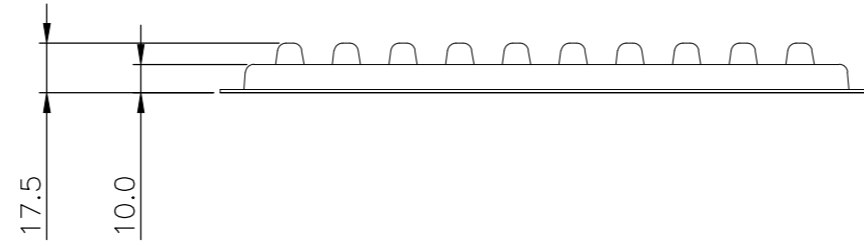
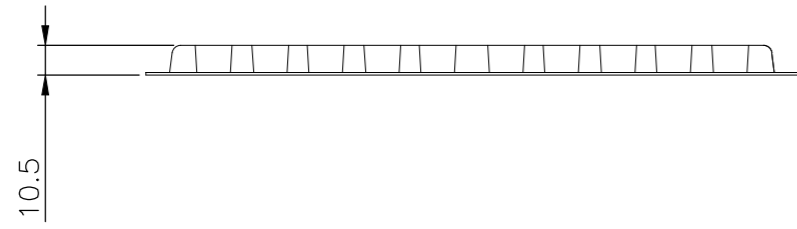

DETAIL A

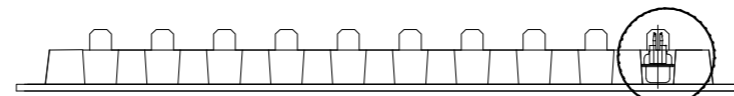

SEE DETAIL A

THIS DRAWING IS A CONTROLLED DOCUMENT.		DWN AJITH PAI 07FEB2017		
DIMENSIONS: mm		CHK DAN GORENC 07FEB2017		
TOLERANCES UNLESS OTHERWISE SPECIFIED:		APVD - 07FEB2017	NAME	
0 PLC ± -		PRODUCT SPEC	D-SUB VERTICAL	
1 PLC ± 0.25		108-130013	37P SKT CONNECTOR	
2 PLC ± 0.15		APPLICATION SPEC	SIZE	RESTRICTED TO
3 PLC ± 0.10		-	A2	-
4 PLC ± -		WEIGHT	CAGE CODE	DRAWING NO
ANGLES ± -		0	00779	C=2301842
FINISH		CUSTOMER DRAWING	SCALE	SHEET
-			1:1	2 of 3
				REV E

2301842

4

3

2

1

THIS DRAWING IS UNPUBLISHED.

RELEASED FOR PUBLICATION

ALL RIGHTS RESERVED.

© COPYRIGHT - By -

REVISIONS

P	LTR	DESCRIPTION	DATE	DWN	APVD
-	-	SEE SHEET 1	-	-	-

PVC TRAY

CARDBOARD BOX

320

460

215

GROSS WEIGHT (Kg)	NET WEIGHT (Kg)	PCS/TRAY	TRAYS /CARTON	QUANTITY Pcs	PART NUMBER
16.619	14.040	40	20	800	2301842-1

THIS DRAWING IS A CONTROLLED DOCUMENT.		DWN	07FEB2017	 TE Connectivity	
DIMENSIONS: mm		CHK	07FEB2017		
TOLERANCES UNLESS OTHERWISE SPECIFIED:		APVD	07FEB2017		
0 PLC ± - 1 PLC ± 0.25 2 PLC ± 0.15 3 PLC ± 0.10 4 PLC ± - ANGLES ± -		NAME	D-SUB VERTICAL 37P SKT CONNECTOR		
MATERIAL		PRODUCT SPEC	108-130013	SIZE	A2
FINISH		APPLICATION SPEC	-	CAGE CODE	00779
		WEIGHT	0	DRAWING NO	C=2301842
		CUSTOMER DRAWING		RESTRICTED TO	-
		SCALE	1:1	SHEET	3 of 3
		REV	E		

1471-9 (1/15)

2301842