

Description

The DIODES™ AL5810 is a constant current Linear LED driver offering an excellent temperature and voltage current stability with output adjustable handling capability. The AL5810 simplifies the design of LED drivers by setting the LED current with an external resistor using standard value resistors.

The AL5810 has an open drain output that can swing from 2.0V up to 60V supply voltage enabling it to drive long LED chains for high-side or low-side LED strings. Its low 0.5V R_{SET} pin is outside of the LED current path and can maintain current accuracy while minimizing the required overheads to regulate the LED current. This reduces its power dissipation when compared to traditional linear LED drivers. It makes it ideal for driving LEDs up to 200mA.

The AL5810 is available in the Wettable Flank W-DFN2020-3 (2mm x 2mm) featuring power dissipation (P_D) up to 2W and TO-252 (DPAK) package with P_D up to 3.8W.

Features

- 2.0V to 60V Wide Input Voltage Range
- An External Resistor for Setting Current
- Low Reference Voltage ($V_{RSET} = 0.5V$)
- Adjustable Sink or Source LED Current Up to 200mA/200mA (W-DFN2020-3/TO-252)
- $\pm 3\%$ LED Current Tolerance @Room Temp
- Parallel Devices to Increase Regulated Current
- Over Temperature Shutdown
- $-40^\circ C$ to $+105^\circ C$ Ambient Temperature Range
- Wettable W-DFN2020-3/SWP (Type A) (2mm x 2mm), P_D up to 2W; TO-252 (DPAK), P_D up to 3.85W
- **Totally Lead-Free & Fully RoHS Compliant (Notes 1 & 2)**
- **Halogen and Antimony Free. "Green" Device (Note 3)**
- **An automotive-compliant part is available under separate datasheet ([AL5810Q](#))**

Applications

- Decorative Lighting
- Display Signage
- AC Lighting Panels
- LED Strings for Dome and Mood Lighting
- Instrumentation Illumination

Pin Assignments

W-DFN2020-3/SWP (Type A)

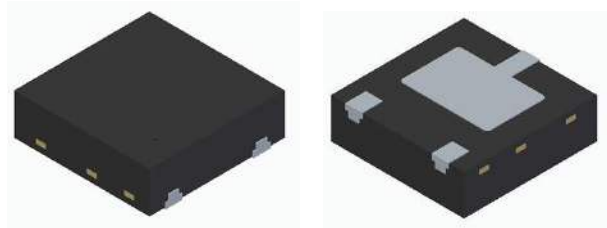

Top View

Bottom View

(Top View)

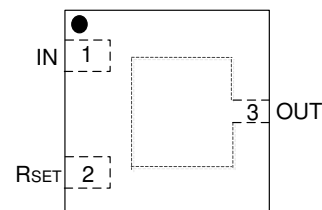

W-DFN2020-3

TO-252 (DPAK)

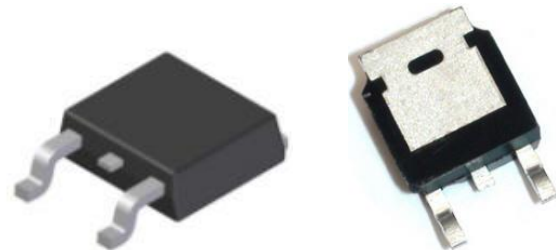

Top View

Bottom View

(Top View)

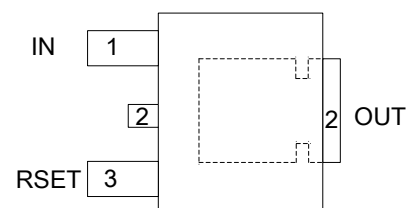

TO-252 (DPAK)

- Notes:
1. No purposely added lead. Fully EU Directive 2002/95/EC (RoHS), 2011/65/EU (RoHS 2) & 2015/863/EU (RoHS 3) compliant.
 2. See <https://www.diodes.com/quality/lead-free/> for more information about Diodes Incorporated's definitions of Halogen- and Antimony-free, "Green" and Lead-free.
 3. Halogen- and Antimony-free "Green" products are defined as those which contain <900ppm bromine, <900ppm chlorine (<1500ppm total Br + Cl) and <1000ppm antimony compounds.

Typical Applications Circuit

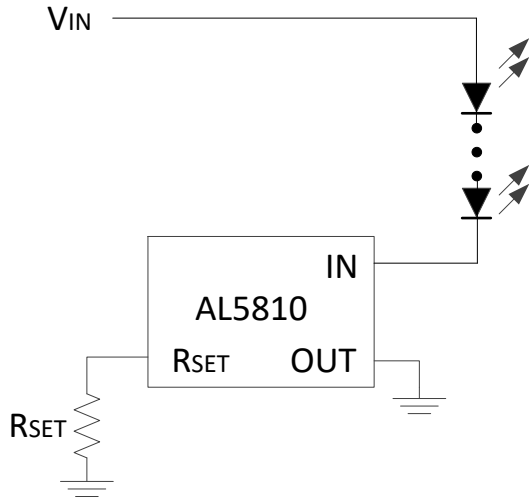

Figure 1. Low-Side Application

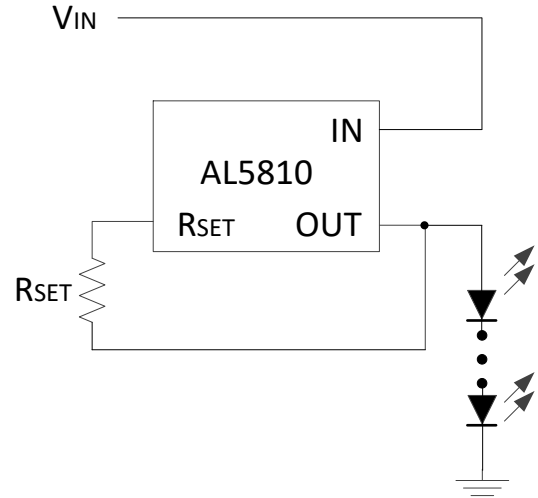

Figure 2. High-Side Application

Pin Descriptions

Pin Name	Pin Number W-DFN2020-3	Pin Number TO-252 (DPAK)	Function
IN	1	1	LED Current Input Terminal Current flows IN to this pin. For low-side application, connect the LED cathode terminal to the IN terminal. For high-side application, connect V _{IN} to the IN terminal.
R _{SET}	2	3	LED Current Setting Pin. For low-side application, connect a resistor from this pin to GND. For high-side application, connect a resistor in between the R _{SET} and OUT terminal. LED current is determined by this equation: $I_{LED} = 750/R_{SET}$
OUT	3	2	LED Current Output Terminal Current flows OUT of this pin. For low-side application, connect the OUT terminal to GND. For high-side application, connect the LED anode terminal to the OUT terminal.

Functional Block Diagram

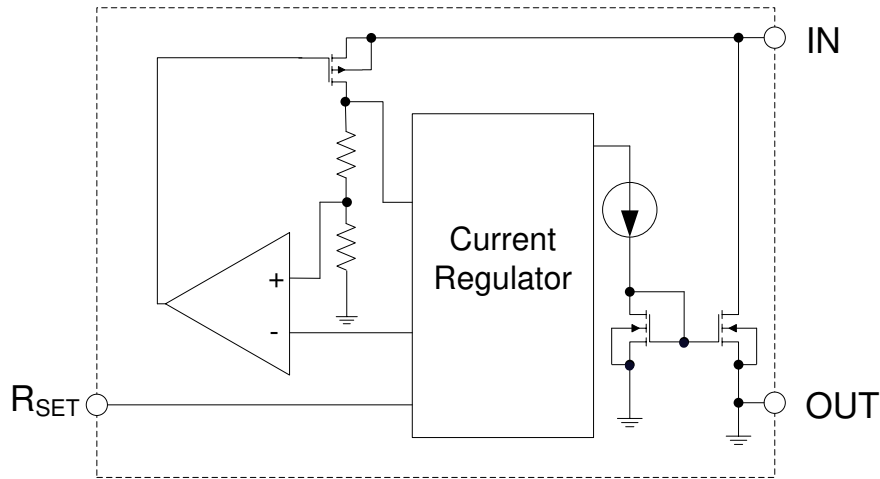

Figure 3. Functional Block Diagram

Absolute Maximum Ratings (@T_A = +25°C, unless otherwise specified.)

Symbol	Parameters	Ratings	Unit
V _{INOUT}	IN Pin Voltage Relative to OUT pin	-0.3 to +66	V
V _{RSET}	R _{SET} Pin Voltage Relative to OUT pin	-0.3 to +6	V
I _{INOUT}	LED Current from IN to OUT	250	mA
ESD HBM	Human Body Model ESD Protection	4,000	V
ESD CDM	Charged Device Model ESD Protection	1,000	V
T _J	Operating Junction Temperature	-40 to +150	°C
T _{ST}	Storage Temperature	-55 to +150	°C

Caution: Stresses greater than the 'Absolute Maximum Ratings' specified above, may cause permanent damage to the device. These are stress ratings only; functional operation of the device at these or any other conditions exceeding those indicated in this specification is not implied. Device reliability may be affected by exposure to absolute maximum rating conditions for extended periods of time. Semiconductor devices are ESD sensitive and may be damaged by exposure to ESD events. Suitable ESD precautions should be taken when handling and transporting these devices.

Package Thermal Data

Package	θ_{JC} Thermal Resistance Junction-to-Case	θ_{JA} Thermal Resistance Junction-to-Ambient	P _D T _A = +25°C, T _J = +150°C
W-DFN2020-3	10.76°C/W	61.66°C/W (Note 4)	2W
TO-252 (DPAK)	2.81°C/W	31.46°C/W (Note 4)	3.85W

Note: 4. Test condition: Device mounted on FR-4 PCB (51mm x 51mm 2oz copper, minimum recommended pad layout on top layer and thermal vias to bottom layer with maximum area ground plane. For better thermal performance, larger copper pad for heat-sink is needed

Recommended Operating Conditions (@ $T_A = +25^\circ\text{C}$, unless otherwise specified.)

Symbol	Parameter	Min	Max	Unit
V_{INOUT}	IN Voltage Range Relative to OUT Pin	2.5	60	V
I_{INOUT}	LED Current (Notes 5 & 6)	1	200	mA
$t_{\text{PWM(ON)}}$	PWM Pulse Width in Dimming Mode On-time	500	—	μS
$t_{\text{PWM(OFF)}}$	PWM Pulse Width in Dimming Mode off-time	500	—	μS
T_J	Operating Junction Temperature Range (Note 8)	-40	+150	$^\circ\text{C}$
T_A	Operating Ambient Temperature Range AEC-Q100 Grade 2 (Note 8)	-40	+105	$^\circ\text{C}$

Electrical Characteristics (@ $T_A = +25^\circ\text{C}$, $V_{\text{INOUT}} = 3.5\text{V}$ (Note 7), $R_{\text{SET}} = 7.5\text{k}\Omega$ unless otherwise specified.)

Symbol	Parameter	Conditions	Min	Typ	Max	Unit		
V_{INOUT}	In-Out Supply Voltage	$I_{\text{OUT}} \geq 100\text{mA}$ (Note 9)	$T_A = -40^\circ\text{C}$ to $+105^\circ\text{C}$	2.5	-	60	V	
		$I_{\text{OUT}} < 100\text{mA}$ (Note 9)		2.0	-	60	V	
V_{RSET}	R_{SET} Voltage	—	$T_A = -40^\circ\text{C}$ to $+105^\circ\text{C}$	—	0.5	—	V	
I_{INOUT}	I_{INOUT} Current Accuracy	$R_{\text{SET}} = 3.75\text{k}\Omega$	$T_A = +25^\circ\text{C}$	186	200	222	mA	
		$R_{\text{SET}} = 5\text{k}\Omega$		141	150	163		
		$R_{\text{SET}} = 7.5\text{k}\Omega$		95	100	105		
		$R_{\text{SET}} = 7.5\text{k}\Omega$	$T_A = -40^\circ\text{C}$ to $+105^\circ\text{C}$	92	100	108		
		$R_{\text{SET}} = 15\text{k}\Omega$		$T_A = -40^\circ\text{C}$ to $+105^\circ\text{C}$	43	50		56
		$R_{\text{SET}} = 75\text{k}\Omega$			6	10		14
$R_{\text{SET}} = 150\text{k}\Omega$	3	5	7					
I_{TEMCO}	Temperature Coefficient of Current Accuracy	$I_{\text{OUT}} = 100\text{mA}$	$T_A = -40^\circ\text{C}$ to $+105^\circ\text{C}$	—	1	—	%	
I_{LINE}	I_{INOUT} Current Line Regulation	$V_{\text{IN}} = 3.5\text{V}$ to 60V (Note 8)	$T_A = +25^\circ\text{C}$	—	1	—	%	
I_{CC}	IN Pin Operating Current	$V_{\text{IN}} = 60\text{V}$ $R_{\text{SET}} = 1\text{M}\Omega$	$T_A = -40^\circ\text{C}$ to $+105^\circ\text{C}$	300	685	1000	μA	
V_{MIN}	Minimum Power Up Voltage	Increase V_{INOUT} (Note 10)	$T_A = -40^\circ\text{C}$ to $+105^\circ\text{C}$	1	1.5	2	V	
$t_{\text{ON_MIN}}$	Minimum On Pulse Width for PWM Dimming	PWM Dimming with External MOSFET Connected to R_{SET} . See PWM Dimming Section. (Notes 11 & 12)	—	500	—	—	μS	
$t_{\text{OFF_MIN}}$	Minimum Off Pulse Width for PWM Dimming	PWM Dimming with External MOSFET Connected to R_{SET} . See PWM Dimming Section. (Notes 11 & 12)	—	500	—	—	μS	
T_{SHDN}	Thermal Shutdown	Junction Temperature (Note 13)	—	—	165	—	$^\circ\text{C}$	
T_{HYS}	Thermal Shutdown Hysteresis	—	—	—	30	—	$^\circ\text{C}$	

- Note:
- For improved accuracy LED current should be greater than 60mA.
 - Maximum LED current is also limited by ambient temperature and power dissipation such that junction temperature should be kept less than or equal to $+150^\circ\text{C}$.
 - All voltages unless otherwise stated are measured with respect to OUT pin.
 - Measured by the percentage of LED current variation when V_{INOUT} varies from 3.5V to 60V.
 - Subject to maximum junction temperature of $+150^\circ\text{C}$ not being exceeded. The Maximum ambient temperature range is limited by device power dissipation; such that its junction temperature should be kept less than or equal to $+150^\circ\text{C}$. See Page 3 for more information on power dissipation. Devices have been qualified to AEC-Q100 Grade 2.
 - Apply the power linearly to the chip until the device starts to turn on.
 - $t_{\text{ON_MIN}}$ time includes the delay and the rise time needed for I_{OUT} to reach 90% of its final value. $t_{\text{OFF_MIN}}$ time is the time needed for I_{OUT} to drop below 10% of its final value.
 - This parameter only guaranteed by design, not tested in production.
 - Ambient temperature at which OTP is triggered may vary depending on application, PCB layout and material used.

Typical Performance Characteristics – (DFN2020-3 100mA, 150mA, 200mA Settings)

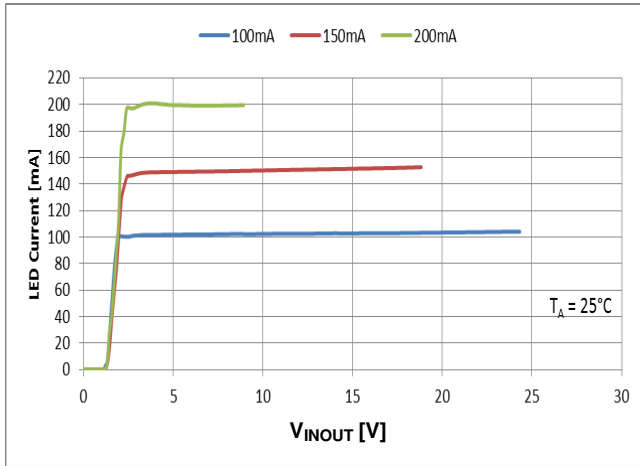

Figure 4. LED Current vs. V_{INOUT}

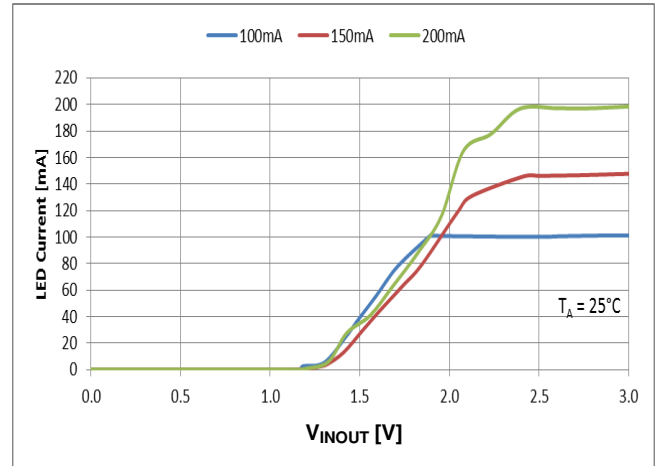

Figure 5. Startup Minimum Operating Voltage

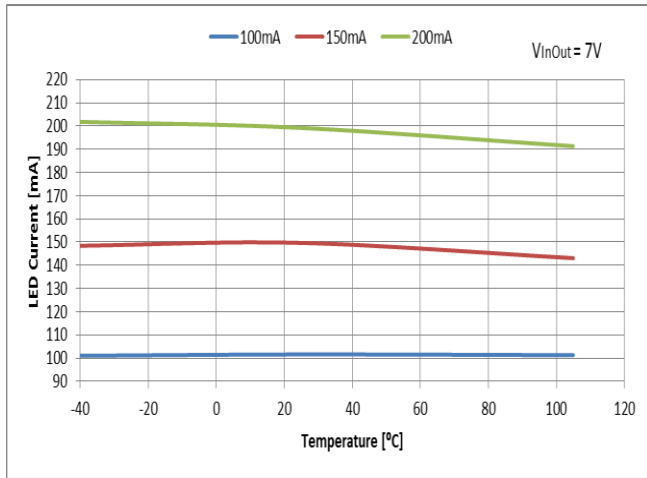

Figure 6. LED Current vs. Ambient Temperature

Typical Performance Characteristics – (TO-252 150mA, 200mA, 250mA (Note 14) Settings)

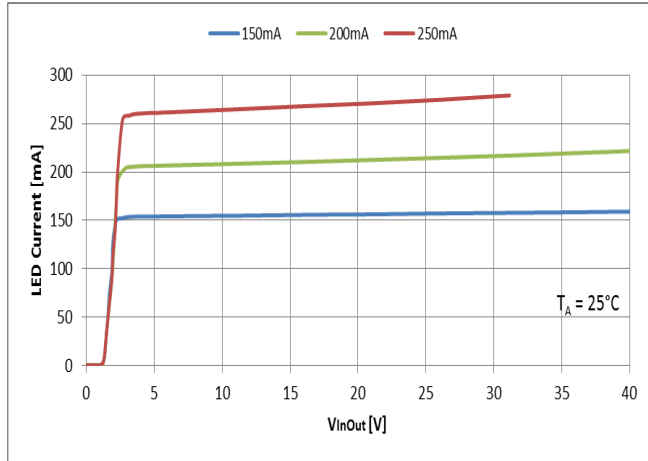

Figure 7. LED Current vs. V_{INOUT}

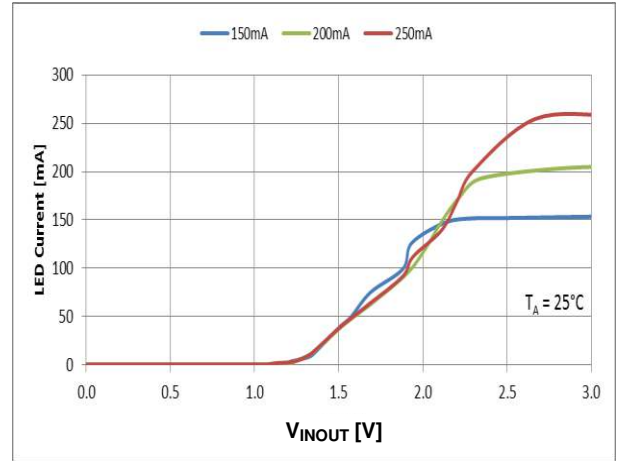

Figure 8. Startup Minimum Operating Voltage

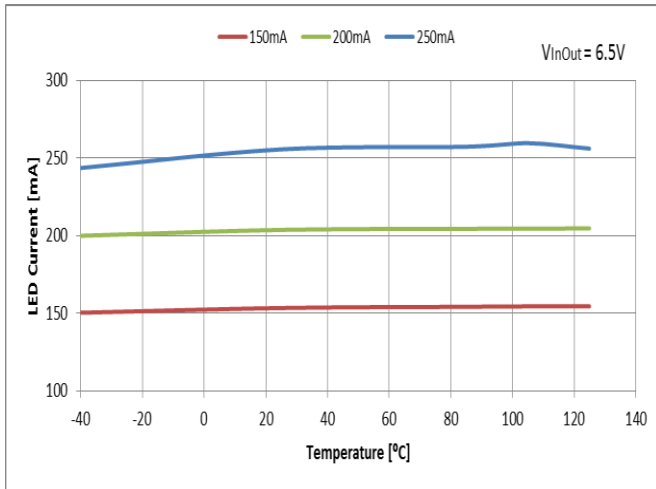

Figure 9. LED Current vs. Ambient Temperature

Note: 14. 250mA data are for reference only, not guaranteed by design and not tested in production.

Application Information

Description

The AL5810 is a linear LED driver and regulates the LED current by sinking current into the IN pin. The AL5810 can support up to 200mA LED current, with $\pm 3\%$ accuracy @25°C. The LED current is set by an external resistor, R_{SET} , connected from the R_{SET} pin to the OUT pin. This resistor supplies the bias current of the AL5810 together with current regulator to set the LED current.

The LED current is determined by this equation:

$$I_{LED} = 1500 * \frac{0.5}{R_{SET}} \quad \text{where 1500 is the current ratio between the IN pin current and } R_{SET} \text{ pin current.}$$

With $R_{SET} = 15k$

$$I_{LED} = 1500 * \frac{0.5}{15k} = 50mA$$

The AL5810, with its 60V capability on the IN pin, allows supply rails up to 60V directly driving LED chains as shown in Figures 10 and 11.

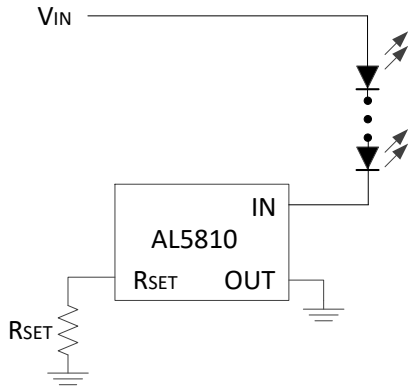

Figure 10. Low-Side Configuration

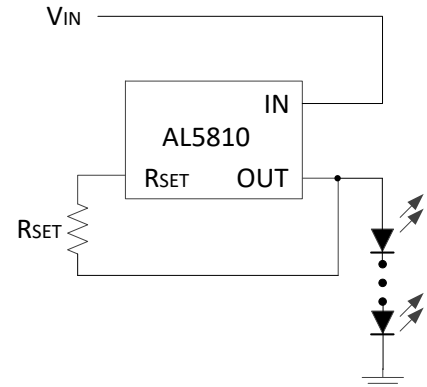
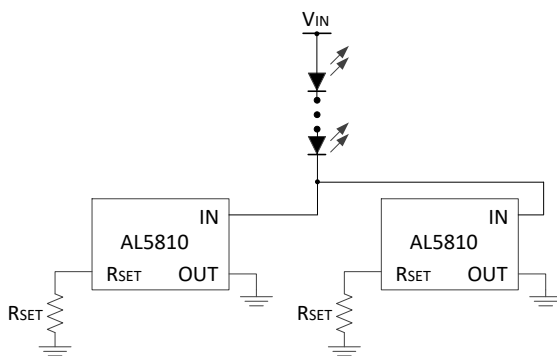
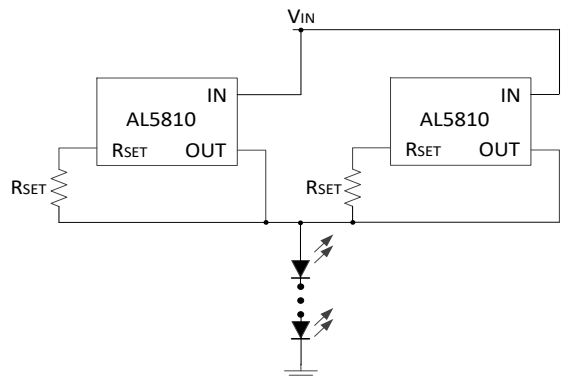

Figure 11. High-Side Configuration

The LED current can be increased by connecting two or more AL5810 in parallel shown in Figure 12.



(a) Low-Side Parallel Configuration



(b) High-Side Parallel Configuration

Figure 12. Higher LED Current by Parallel Configuration of AL5810

Application Information (cont.)

PWM Dimming

The AL5810 can be used to provide LED current dimming by driving the R_{SET} pin via the current setting resistor (R_{SET}) and a series MOSFET switch to ground (Figure 13). The R_{SET} pin current is then effectively switched on and off causing the LED current to turn on and off. The linearity is shown in Figure 14.

Test conditions (Figure 14): $V_{in} = 6V$, 1 LED low side configuration, $R_{set} = 7.5k\Omega$, $I_{LED} = 100mA$, N-Channel MOSFET (P/N: BC817-16Q-7-F), PWM frequency 200Hz–500Hz Square wave, 0-4V gate voltage

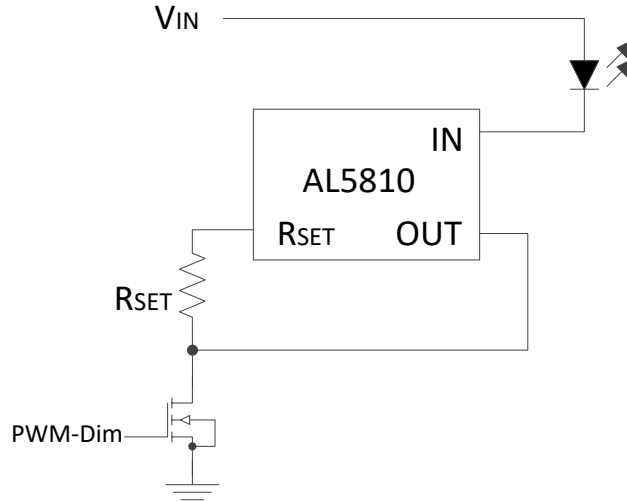

Figure 13. PWM Dimming by External MOSFET

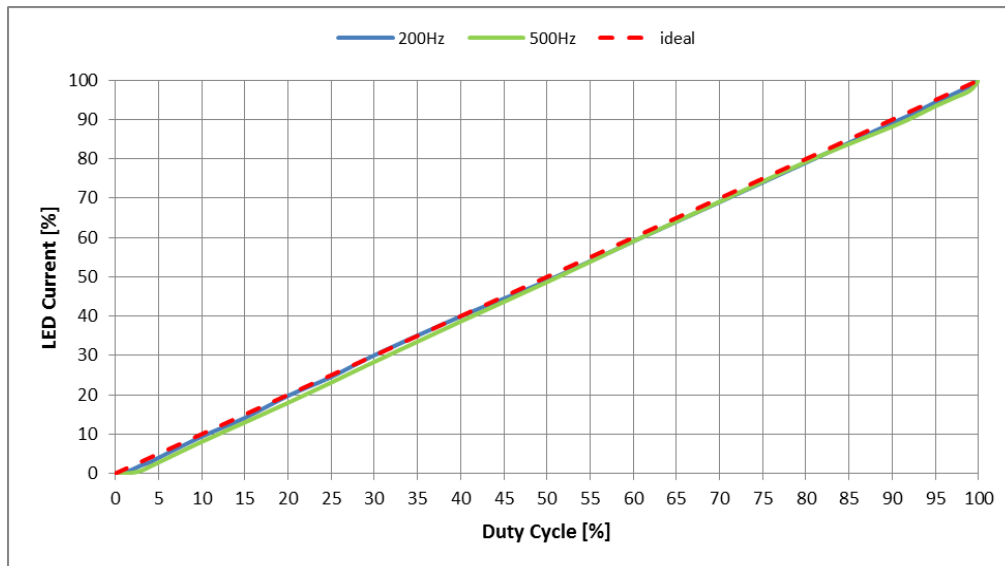

Figure 14. PWM Dimming Linearity

Application Information (cont.)

Recommended PWM Frequency and Dimming Range

PWM Frequency (Hz)	Duty Cycle (%)	
	Min	Max
200	10	90
500	25	75

Use the following formula to calculate the Min and Max duty cycle:

Min. Duty cycle (%) = $(t_{ON_MIN}) / (\text{time period of the PWM signal})$

Max. Duty cycle (%) = $100\% - ((t_{OFF_MIN}) / (\text{time period of the PWM signal}))$

Notes: $t_{ON_MIN} = 500\mu\text{S}$ (Min. value), and $t_{OFF_MIN} = 500\mu\text{S}$ (Min. value) are listed in the Electrical Characteristics table on page 4.

Thermal Considerations

When designing linear LED drivers careful consideration must be given to the power dissipation within the LED driver and PCB layout / heat sinking. A Linear LED driver has to be able to handle the large potential input voltage variations due to the supply voltage tolerance and also the variation in LED forward voltage due to binning and temperature. This can cause a large potential difference across the LED driver resulting in a larger than anticipated power dissipation.

In automotive applications when the engine is running, the typical input voltage range varies from 13.5-14.7V.

The recommended minimum V_{INOUT} voltage of 2.5V enables the AL5810 to drive 2 LED in series from the 12V battery voltage (assuming $V_{LED} < 3.25\text{V}$).

The AL5810's power dissipation under these conditions will be:

$$V_{INOUT} * I_{LED} = 2.5 * I_{LED}$$

So for the 100mA AL5810 under these conditions this equals:

$$2.5\text{V} * 100\text{mA} = 250\text{mW}$$

Under maximum input conditions (14.7V), $V_{INOUT} = 14.7\text{V} - 6.5\text{V}$ (2 LEDs Voltage) the AL5810's power dissipation will be:

$$V_{INOUT} * I_{LED} = 8.2 * I_{LED}$$

So for the 100mA AL5810 this equals:

$$8.2\text{V} * 100\text{mA} = 820\text{mW}$$

Figure 15 shows the AL5810's power dissipation capability, which varies with PCB size and area of metal associated with the ground plane used for heat sinking. By increasing the area on the top layer, the thermal impedance could be improved.

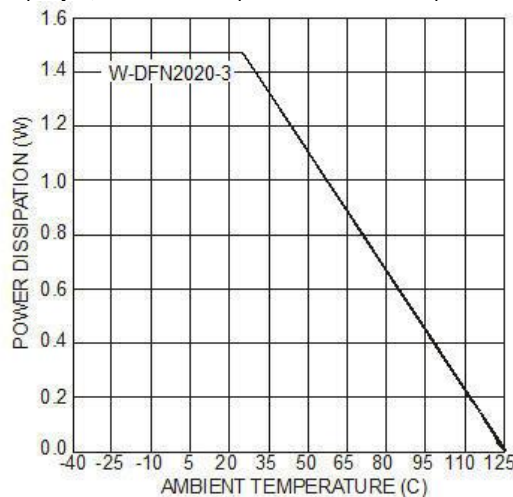
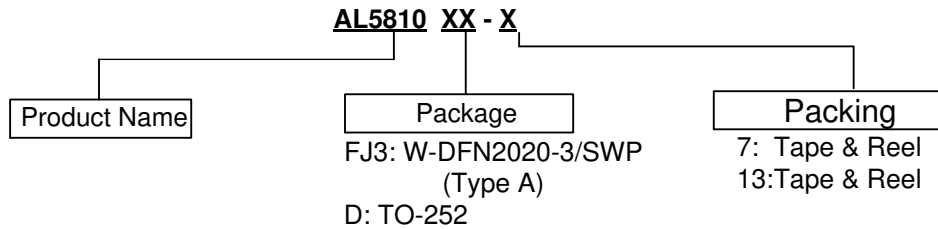

Figure 15. Power Dissipation Derating

Ordering Information (Note 15)



Device	Package Code	Packaging	Tape and Reel	
			Quantity	Part Number Suffix
AL5810FJ3-7	FJ3	W-DFN2020-3/SWP (Type A)	3000/Tape & Reel	-7
AL5810D-13	D	TO-252 (DPAK)	2500/Tape & Reel	-13

Note: 15. For packaging details, go to our website at <https://www.diodes.com/design/support/packaging/diodes-packaging/>.

Marking Information

Package: W-DFN2020-3/SWP (Type A)

(Top View)

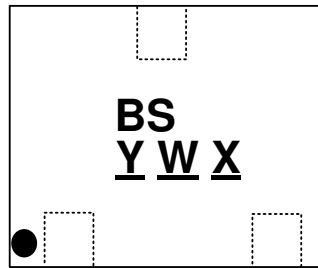

BS : Identification Code
 Y : Year: 0~9
 W : Week: A~Z: 1~26 Week;
 a~z; 27~52 Week; z Represents
 52 and 53 Week
 X : Internal Code

Package: TO-252 (DPAK)

(Top View)

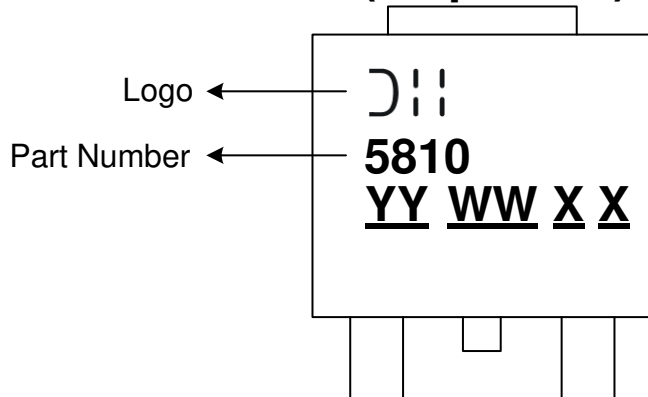

YY : Year : 19 to 20
WW : Week : 01 to 52, 52 represents
 week #52
XX : Internal Code

Package Outline Dimensions (All dimensions in mm.)

Please see <https://www.diodes.com/package-outlines.html> for latest version.

Package W-DFN2020-3/SWP (Type A)

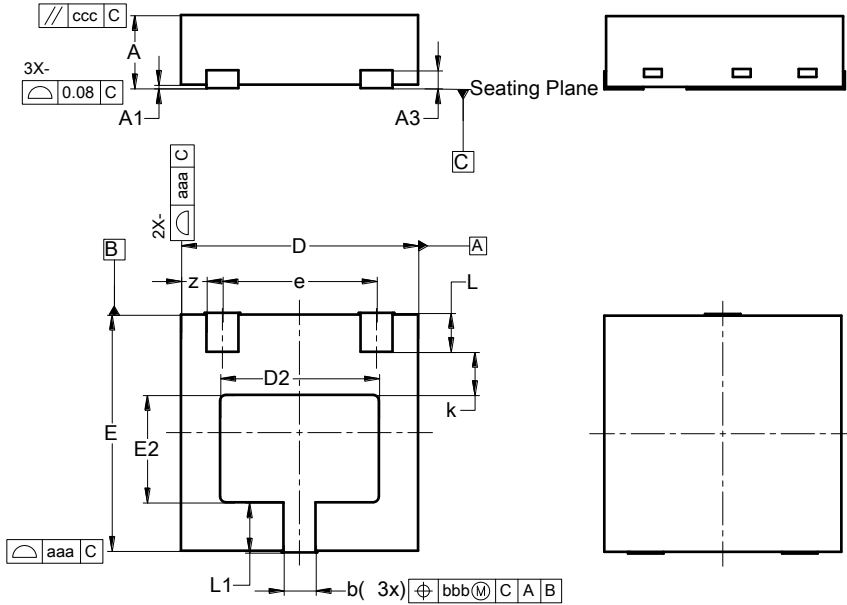

W-DFN2020-3 /SWP (Type A)			
Dim	Min	Max	Typ
A	0.57	0.67	0.62
A1	0.00	0.05	0.03
A3	0.100	--	0.152
b	0.22	0.32	0.27
D	1.95	2.05	2.00
D2	1.24	1.44	1.34
E	1.95	2.05	2.00
E2	0.81	1.01	0.91
e	--	--	1.30
k	--	--	0.365
L	0.28	0.38	0.33
L1	0.375	0.475	0.425
z	--	--	0.215
aaa	0.25		
bbb	0.10		
ccc	0.10		
All Dimensions in mm			

Package TO-252 (DPAK)

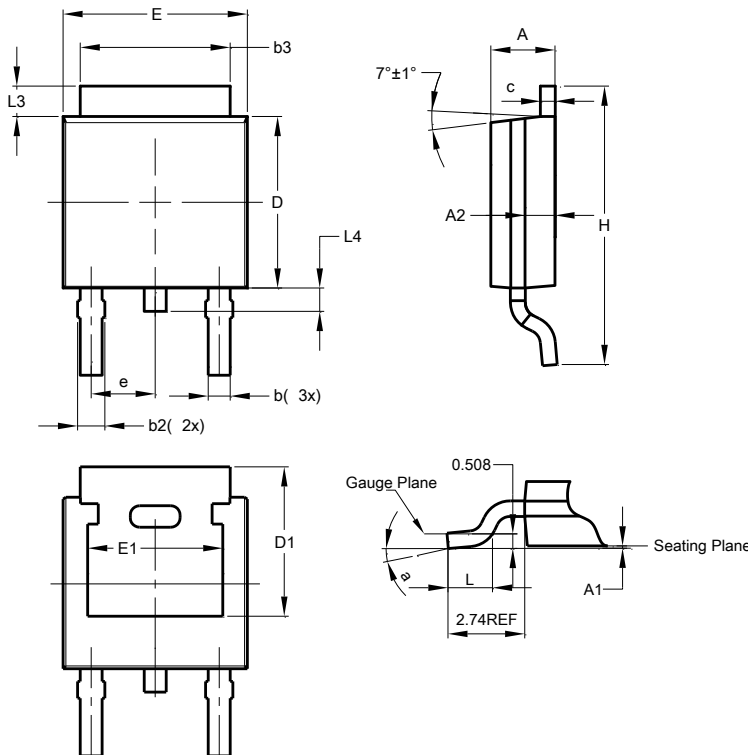

TO252 (DPAK)			
Dim	Min	Max	Typ
A	2.19	2.39	2.29
A1	0.00	0.13	0.08
A2	0.97	1.17	1.07
b	0.64	0.88	0.783
b2	0.76	1.14	0.95
b3	5.21	5.50	5.33
c	0.45	0.58	0.531
D	6.00	6.20	6.10
D1	5.21	--	--
e	2.286 BSC		
E	6.45	6.70	6.58
E1	4.32	--	--
H	9.40	10.41	9.91
L	1.40	1.78	1.59
L3	0.88	1.27	1.08
L4	0.64	1.02	0.83
a	0°	10°	--
All Dimensions in mm			

Suggested Pad Layout

Please see <https://www.diodes.com/package-outlines.html> for latest version.

Package: W-DFN2020-3/SWP (Type A)

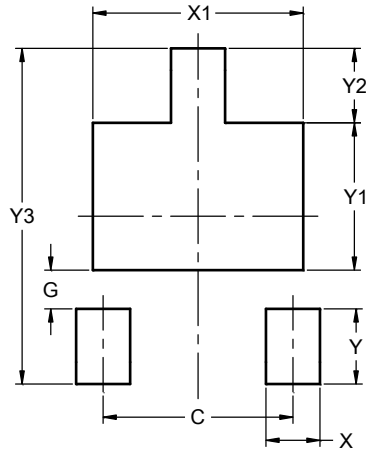

Dimensions	Value (in mm)
C	1.300
G	0.265
X	0.370
X1	1.440
Y	0.515
Y1	1.010
Y2	0.510
Y3	2.300

Package TO-252 (DPAK)

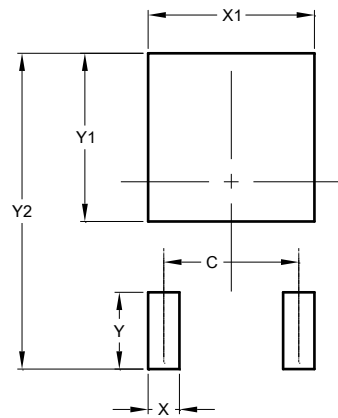

Dimensions	Value (in mm)
C	4.572
X	1.060
X1	5.632
Y	2.600
Y1	5.700
Y2	10.700

Mechanical Data

Package W-DFN2020-3/SWP (Type A)

- Moisture Sensitivity: MSL Level 1 per J-STD-020
- Terminals: Finish - Matte Tin Plated Leads, Solderable per JESD22-B102
- Weight: 0.0071 grams (Approximate)

Package TO-252 (DPAK)

- Moisture Sensitivity: MSL Level 1 per J-STD-020
- Terminals: Finish - Matte Tin Plated Leads, Solderable per JESD22-B102
- Weight: 0.33 grams (Approximate)

IMPORTANT NOTICE

1. DIODES INCORPORATED (Diodes) AND ITS SUBSIDIARIES MAKE NO WARRANTY OF ANY KIND, EXPRESS OR IMPLIED, WITH REGARDS TO ANY INFORMATION CONTAINED IN THIS DOCUMENT, INCLUDING, BUT NOT LIMITED TO, THE IMPLIED WARRANTIES OF MERCHANTABILITY, FITNESS FOR A PARTICULAR PURPOSE OR NON-INFRINGEMENT OF THIRD PARTY INTELLECTUAL PROPERTY RIGHTS (AND THEIR EQUIVALENTS UNDER THE LAWS OF ANY JURISDICTION).
2. The Information contained herein is for informational purpose only and is provided only to illustrate the operation of Diodes' products described herein and application examples. Diodes does not assume any liability arising out of the application or use of this document or any product described herein. This document is intended for skilled and technically trained engineering customers and users who design with Diodes' products. Diodes' products may be used to facilitate safety-related applications; however, in all instances customers and users are responsible for (a) selecting the appropriate Diodes products for their applications, (b) evaluating the suitability of Diodes' products for their intended applications, (c) ensuring their applications, which incorporate Diodes' products, comply the applicable legal and regulatory requirements as well as safety and functional-safety related standards, and (d) ensuring they design with appropriate safeguards (including testing, validation, quality control techniques, redundancy, malfunction prevention, and appropriate treatment for aging degradation) to minimize the risks associated with their applications.
3. Diodes assumes no liability for any application-related information, support, assistance or feedback that may be provided by Diodes from time to time. Any customer or user of this document or products described herein will assume all risks and liabilities associated with such use, and will hold Diodes and all companies whose products are represented herein or on Diodes' websites, harmless against all damages and liabilities.
4. Products described herein may be covered by one or more United States, international or foreign patents and pending patent applications. Product names and markings noted herein may also be covered by one or more United States, international or foreign trademarks and trademark applications. Diodes does not convey any license under any of its intellectual property rights or the rights of any third parties (including third parties whose products and services may be described in this document or on Diodes' website) under this document.
5. Diodes' products are provided subject to Diodes' Standard Terms and Conditions of Sale (<https://www.diodes.com/about/company/terms-and-conditions/terms-and-conditions-of-sales/>) or other applicable terms. This document does not alter or expand the applicable warranties provided by Diodes. Diodes does not warrant or accept any liability whatsoever in respect of any products purchased through unauthorized sales channel.
6. Diodes' products and technology may not be used for or incorporated into any products or systems whose manufacture, use or sale is prohibited under any applicable laws and regulations. Should customers or users use Diodes' products in contravention of any applicable laws or regulations, or for any unintended or unauthorized application, customers and users will (a) be solely responsible for any damages, losses or penalties arising in connection therewith or as a result thereof, and (b) indemnify and hold Diodes and its representatives and agents harmless against any and all claims, damages, expenses, and attorney fees arising out of, directly or indirectly, any claim relating to any noncompliance with the applicable laws and regulations, as well as any unintended or unauthorized application.
7. While efforts have been made to ensure the information contained in this document is accurate, complete and current, it may contain technical inaccuracies, omissions and typographical errors. Diodes does not warrant that information contained in this document is error-free and Diodes is under no obligation to update or otherwise correct this information. Notwithstanding the foregoing, Diodes reserves the right to make modifications, enhancements, improvements, corrections or other changes without further notice to this document and any product described herein. This document is written in English but may be translated into multiple languages for reference. Only the English version of this document is the final and determinative format released by Diodes.
8. Any unauthorized copying, modification, distribution, transmission, display or other use of this document (or any portion hereof) is prohibited. Diodes assumes no responsibility for any losses incurred by the customers or users or any third parties arising from any such unauthorized use.
9. This Notice may be periodically updated with the most recent version available at <https://www.diodes.com/about/company/terms-and-conditions/important-notice>

DIODES is a trademark of Diodes Incorporated in the United States and other countries.
The Diodes logo is a registered trademark of Diodes Incorporated in the United States and other countries.
© 2022 Diodes Incorporated. All Rights Reserved.

www.diodes.com