

STEVAL-IDB007V1 evaluation platform based on the BlueNRG-1

Data brief

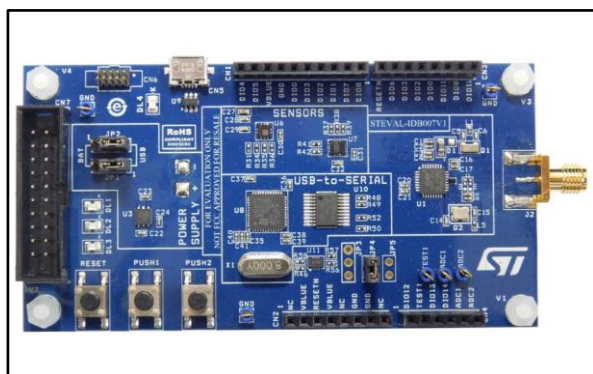

- USB to serial bridge for providing I/O channel with the BlueNRG-1 device
- Jumper for measuring current for BlueNRG-1 only
- RoHS compliant

Description

The STEVAL-IDB007V1 is an evaluation platform based on the BlueNRG-1, low power Bluetooth® smart system on chip, compliant with the Bluetooth® v4.2 specification and supporting master, slave and simultaneous master-and-slave roles.

The STEVAL-IDB007V1 also provides a set of hardware resources for implementing a wide range of application scenarios: sensor data (accelerometer, pressure and temperature sensor), remote control (buttons and LEDs) and manage debug messages though USB virtual COM.

Three power options are available (USB only, battery only, external power supply + USB) for high application development and testing flexibility.

Features

- Bluetooth® SMART board based on the BlueNRG-1 Bluetooth low energy system on chip
- Associated BlueNRG-1 development kit SW package including firmware and documentation
- Up to +8 dBm available output power (at antenna connector)
- Excellent receiver sensitivity (-88 dBm)
- Very low power consumption: 7.7 mA RX and 8.3 mA TX at -2 dBm
- Bluetooth® low energy v4.2 compliant, supports master, slave and simultaneous master-and-slave roles
- Integrated balun which integrates a matching network and harmonics filter
- SMA connector for antenna or measuring equipment
- 3 user LEDs
- 2 user buttons
- 3D digital accelerometer and 3D digital gyroscope
- MEMS pressure sensor with embedded temperature sensor
- Battery holder
- JTAG debug connector

1 Schematic diagrams

Figure 1: STEVAL-IDB007V1 arduino connectors

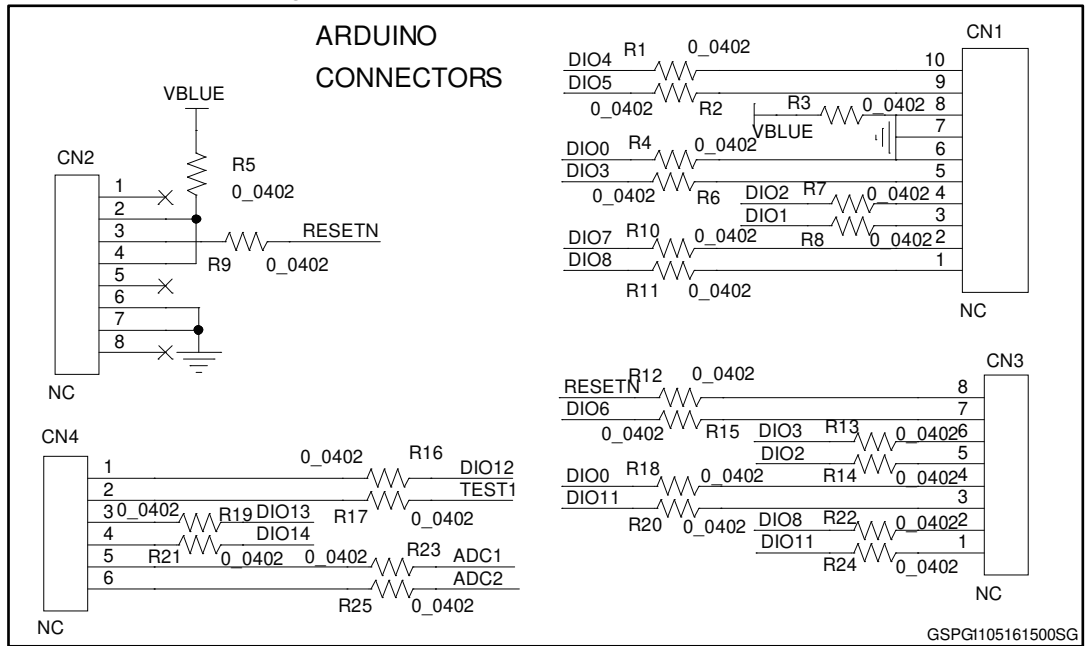

Figure 2: STEVAL-IDB007V1 JTAG

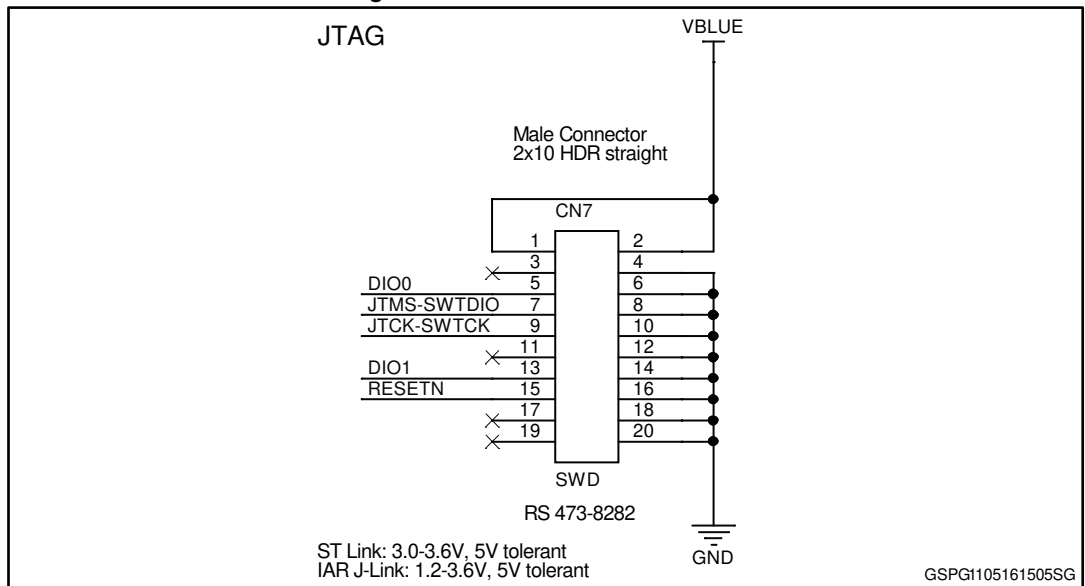

Figure 3: STEVAL-IDB007V1 BlueNRG-1

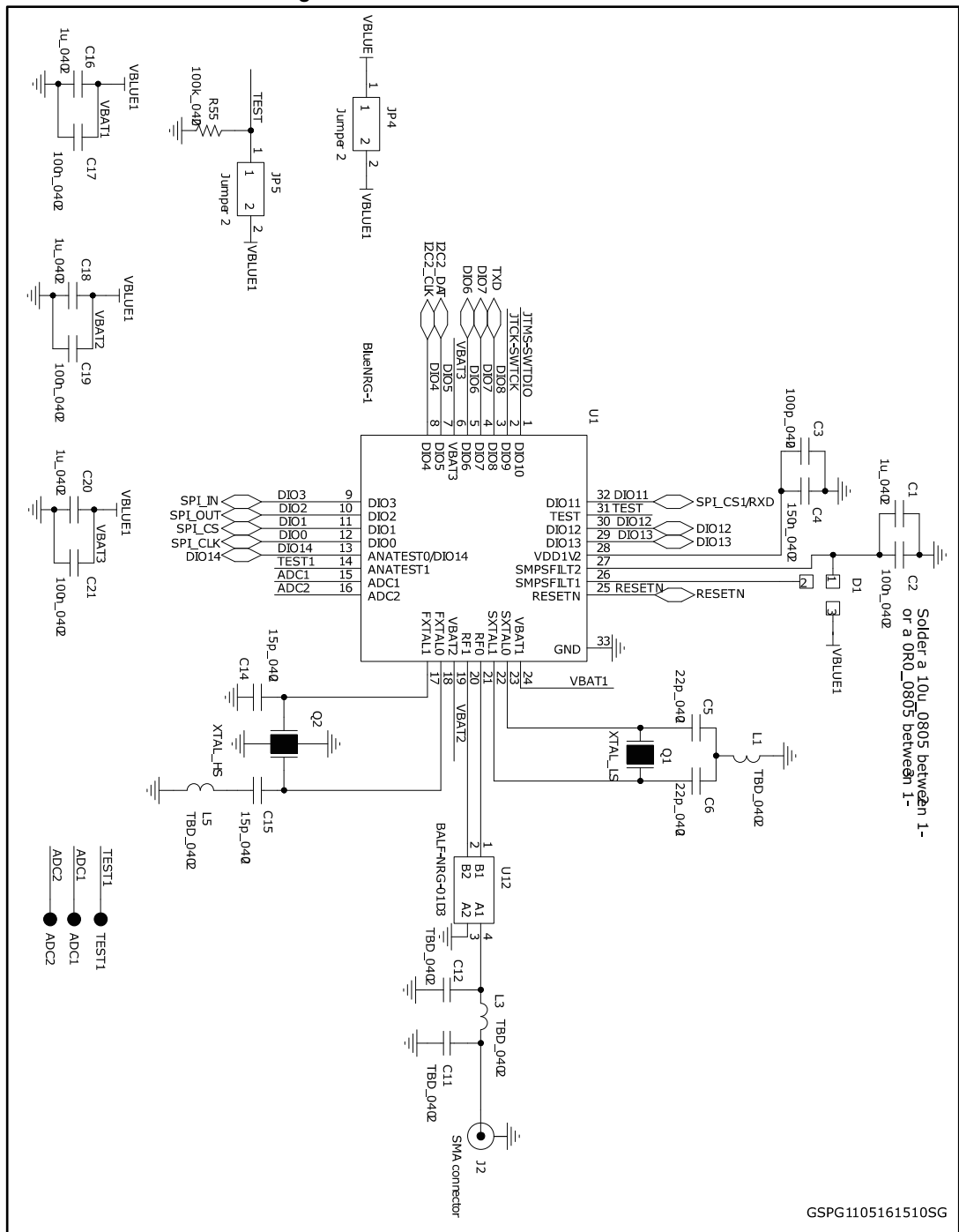

Figure 4: STEVAL-IDB007V1 power management, sensors

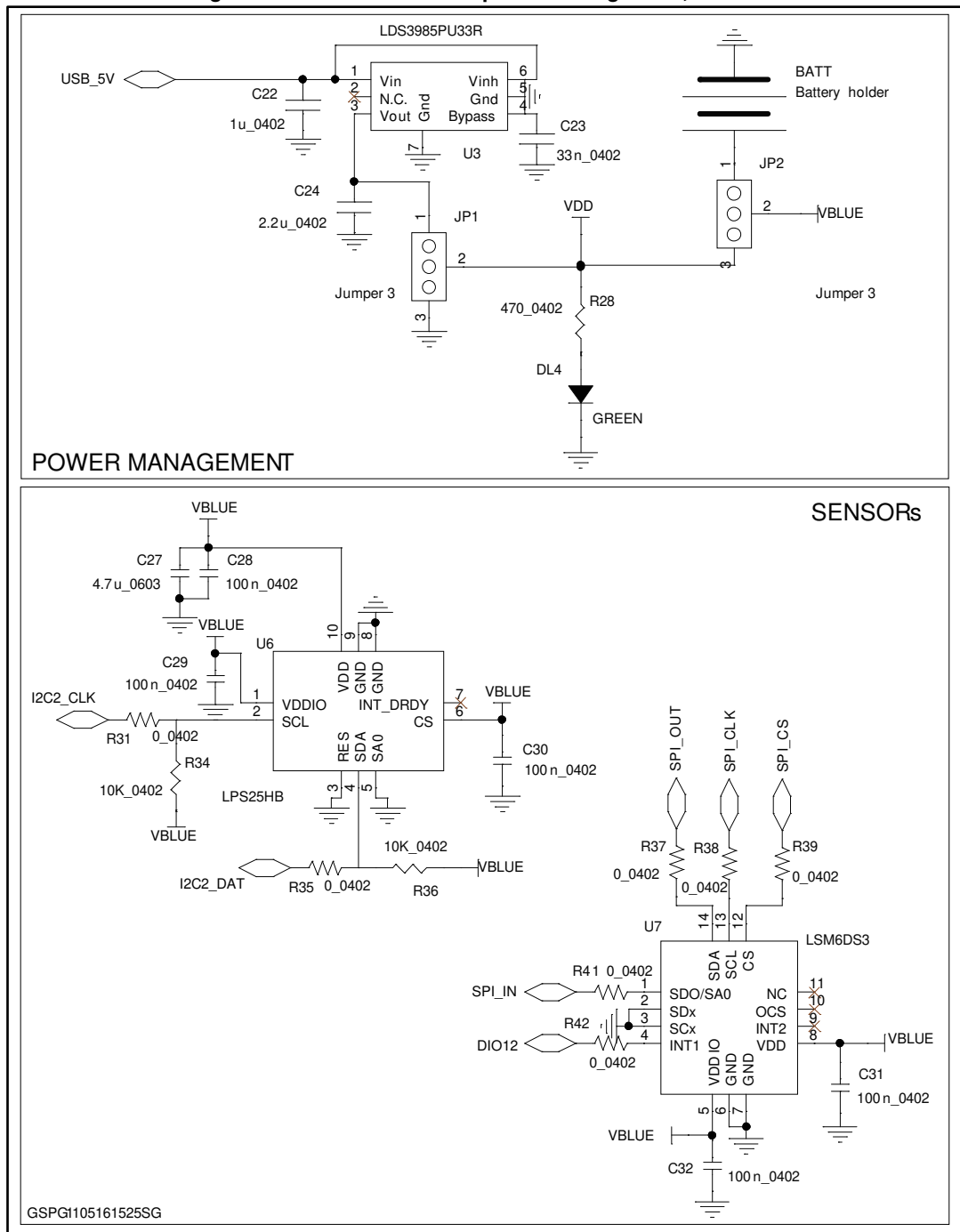

Figure 5: STEVAL-IDB007V1 buttons and LEDs

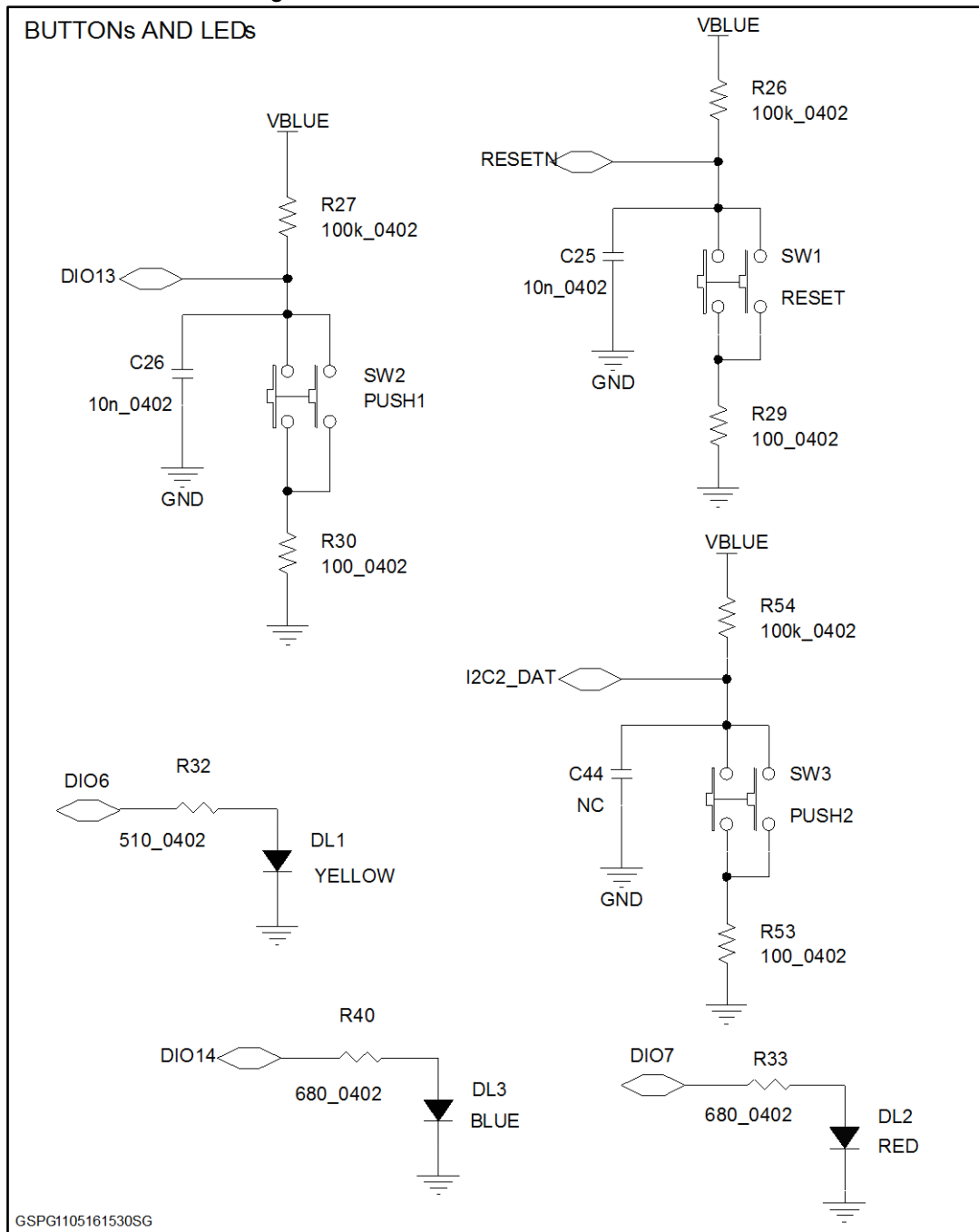

Figure 6: STEVAL-IDB007V1 micro

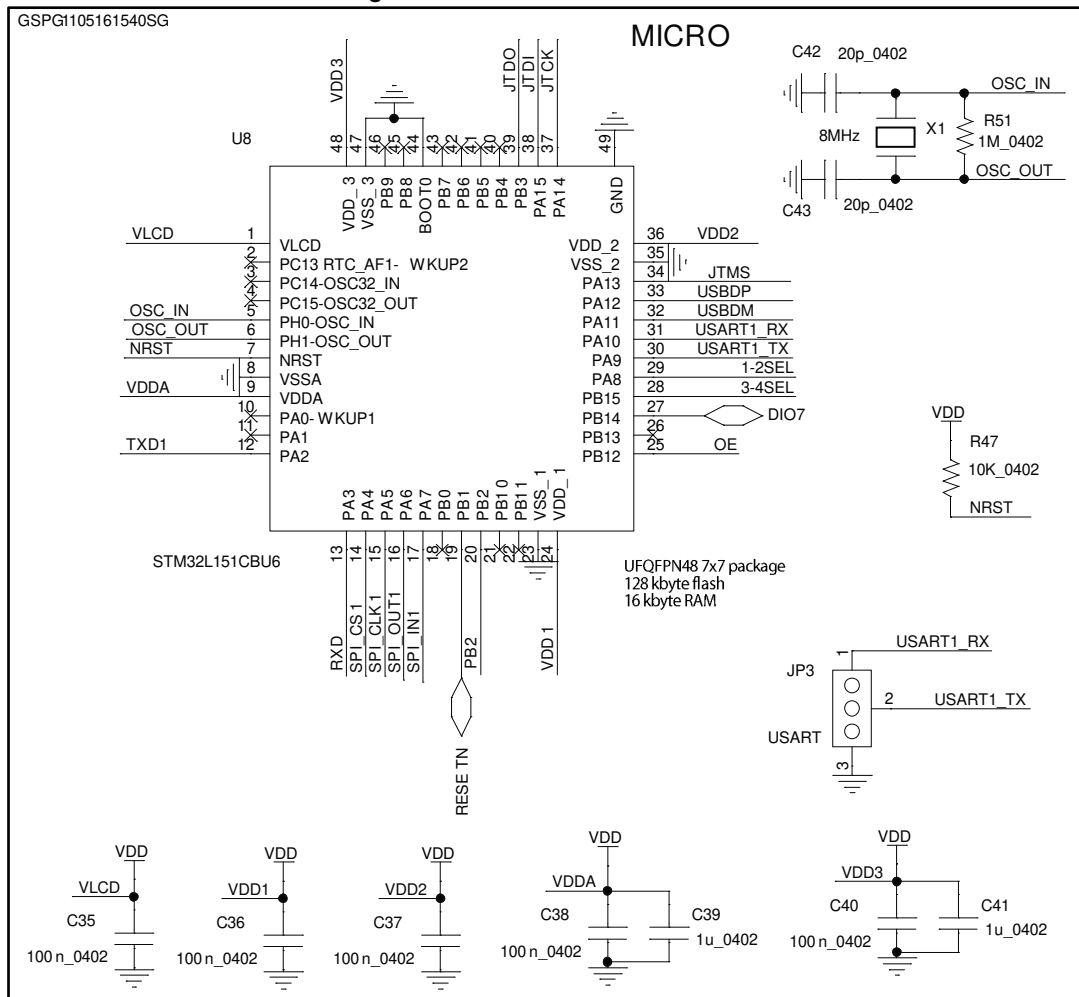
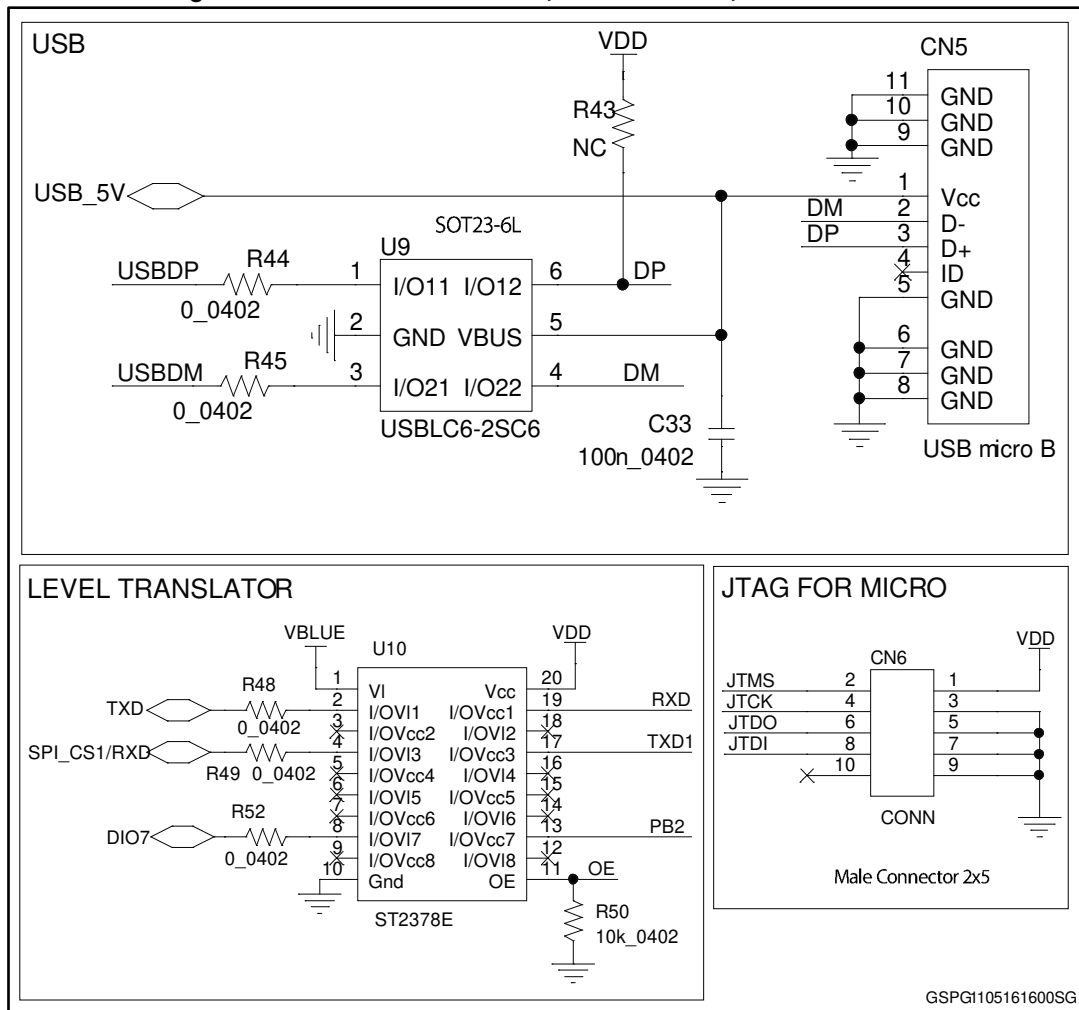

Figure 7: STEVAL-IDB007V1 USB, level translator, JTAG for micro



2 Revision history

Table 1: Document revision history

Date	Version	Changes
16-May-2016	1	Initial release.
19-Dec-2016	2	Updated board photo on the cover page.

IMPORTANT NOTICE – PLEASE READ CAREFULLY

STMicroelectronics NV and its subsidiaries ("ST") reserve the right to make changes, corrections, enhancements, modifications, and improvements to ST products and/or to this document at any time without notice. Purchasers should obtain the latest relevant information on ST products before placing orders. ST products are sold pursuant to ST's terms and conditions of sale in place at the time of order acknowledgement.

Purchasers are solely responsible for the choice, selection, and use of ST products and ST assumes no liability for application assistance or the design of Purchasers' products.

No license, express or implied, to any intellectual property right is granted by ST herein.

Resale of ST products with provisions different from the information set forth herein shall void any warranty granted by ST for such product.

ST and the ST logo are trademarks of ST. All other product or service names are the property of their respective owners.

Information in this document supersedes and replaces information previously supplied in any prior versions of this document.

© 2016 STMicroelectronics – All rights reserved