



MICROCHIP

MCP2030
Bidirectional Communication
Demo Kit
User's Guide

Note the following details of the code protection feature on Microchip devices:

- Microchip products meet the specification contained in their particular Microchip Data Sheet.
- Microchip believes that its family of products is one of the most secure families of its kind on the market today, when used in the intended manner and under normal conditions.
- There are dishonest and possibly illegal methods used to breach the code protection feature. All of these methods, to our knowledge, require using the Microchip products in a manner outside the operating specifications contained in Microchip's Data Sheets. Most likely, the person doing so is engaged in theft of intellectual property.
- Microchip is willing to work with the customer who is concerned about the integrity of their code.
- Neither Microchip nor any other semiconductor manufacturer can guarantee the security of their code. Code protection does not mean that we are guaranteeing the product as "unbreakable."

Code protection is constantly evolving. We at Microchip are committed to continuously improving the code protection features of our products. Attempts to break Microchip's code protection feature may be a violation of the Digital Millennium Copyright Act. If such acts allow unauthorized access to your software or other copyrighted work, you may have a right to sue for relief under that Act.

Information contained in this publication regarding device applications and the like is provided only for your convenience and may be superseded by updates. It is your responsibility to ensure that your application meets with your specifications. MICROCHIP MAKES NO REPRESENTATIONS OR WARRANTIES OF ANY KIND WHETHER EXPRESS OR IMPLIED, WRITTEN OR ORAL, STATUTORY OR OTHERWISE, RELATED TO THE INFORMATION, INCLUDING BUT NOT LIMITED TO ITS CONDITION, QUALITY, PERFORMANCE, MERCHANTABILITY OR FITNESS FOR PURPOSE. Microchip disclaims all liability arising from this information and its use. Use of Microchip devices in life support and/or safety applications is entirely at the buyer's risk, and the buyer agrees to defend, indemnify and hold harmless Microchip from any and all damages, claims, suits, or expenses resulting from such use. No licenses are conveyed, implicitly or otherwise, under any Microchip intellectual property rights.

Trademarks

The Microchip name and logo, the Microchip logo, Accuron, dsPIC, KEELOQ, microID, MPLAB, PIC, PICmicro, PICSTART, PRO MATE, PowerSmart, rfPIC and SmartShunt are registered trademarks of Microchip Technology Incorporated in the U.S.A. and other countries.

AmpLab, FilterLab, Migratable Memory, MXDEV, MXLAB, SEEVAL, SmartSensor and The Embedded Control Solutions Company are registered trademarks of Microchip Technology Incorporated in the U.S.A.

Analog-for-the-Digital Age, Application Maestro, CodeGuard, dsPICDEM, dsPICDEM.net, dsPICworks, ECAN, ECONOMONITOR, FanSense, FlexROM, fuzzyLAB, In-Circuit Serial Programming, ICSP, ICEPIC, Linear Active Thermistor, Mindi, MiWi, MPASM, MPLIB, MPLINK, PICKIT, PICDEM, PICDEM.net, PICLAB, PICTail, PowerCal, PowerInfo, PowerMate, PowerTool, REAL ICE, rFLAB, rfPICDEM, Select Mode, Smart Serial, SmartTel, Total Endurance, UNI/O, WiperLock and ZENA are trademarks of Microchip Technology Incorporated in the U.S.A. and other countries.

SQTP is a service mark of Microchip Technology Incorporated in the U.S.A.

All other trademarks mentioned herein are property of their respective companies.

© 2006, Microchip Technology Incorporated, Printed in the U.S.A., All Rights Reserved.

 Printed on recycled paper.

QUALITY MANAGEMENT SYSTEM
CERTIFIED BY DNV
== ISO/TS 16949:2002 ==

Microchip received ISO/TS-16949:2002 certification for its worldwide headquarters, design and wafer fabrication facilities in Chandler and Tempe, Arizona, Gresham, Oregon and Mountain View, California. The Company's quality system processes and procedures are for its PIC® 8-bit MCUs, KEELOQ® code hopping devices, Serial EEPROMs, microperipherals, nonvolatile memory and analog products. In addition, Microchip's quality system for the design and manufacture of development systems is ISO 9001:2000 certified.



MCP2030 BIDIRECTIONAL COMMUNICATION DEMO KIT USER'S GUIDE

Table of Contents

Preface	1
Introduction.....	1
Document Layout	1
Conventions Used in this Guide	2
Recommended Reading.....	2
The Microchip Web Site	3
Customer Support	3
Document Revision History	4
Chapter 1. Quick Start	5
1.1 Introduction	5
Chapter 2. System Overview	7
2.1 Overview	7
2.2 Operational Overview	8
2.3 Features	10
Chapter 3. Hardware and Firmware Overview	11
3.1 Introduction	11
3.2 MCP2030 Base Station Demo Board	11
3.3 MCP2030 Transponder Demo Board	14
Appendix A. Schematic and Layouts	19
A.1 Introduction	19
A.2 Transponder Demo Board - Schematic	20
A.3 Transponder Demo Board - Top Layer and Silk Screen	21
A.4 Transponder Demo Board - Bottom Layer	21
A.5 Base Station Demo Board - Schematic (Page 1)	22
A.6 Base Station Demo Board - Schematic (Page 2)	23
A.7 Base Station Demo Board - Top Layer and Silk Screen	24
A.8 Base Station Demo Board - Bottom Layer	24
Appendix B. Bill of Materials (BOM)	25
B.1 Introduction	25
Worldwide Sales and Service	30

MCP2030 Bidirectional Communication Demo Kit User's Guide

NOTES:



MCP2030 BIDIRECTIONAL COMMUNICATION DEMO KIT USER'S GUIDE

Preface

NOTICE TO CUSTOMERS

All documentation becomes dated, and this manual is no exception. Microchip tools and documentation are constantly evolving to meet customer needs, so some actual dialogs and/or tool descriptions may differ from those in this document. Please refer to our web site (www.microchip.com) to obtain the latest documentation available.

Documents are identified with a "DS" number. This number is located on the bottom of each page, in front of the page number. The numbering convention for the DS number is "DSXXXXXA", where "XXXXX" is the document number and "A" is the revision level of the document.

For the most up-to-date information on development tools, see the MPLAB® IDE on-line help. Select the Help menu, and then Topics to open a list of available on-line help files.

INTRODUCTION

This chapter contains general information that will be useful to know before using the MCP2030 Bidirectional Communication Demo Kit. Items discussed in this chapter include:

- Document Layout
- Conventions Used in this Guide
- Recommended Reading
- The Microchip Web Site
- Customer Support

DOCUMENT LAYOUT

This document describes the MCP2030 Bidirectional Communication Demo Kit. The manual layout is as follows:

- **Chapter 1. "Quick Start"** – Describes the MCP2030 Bidirectional Communication Demo Kit set-up instructions.
- **Chapter 2. "System Overview"** – A system overview of the MCP2030 Bidirectional Communication Demo Kit is discussed.
- **Chapter 3. "Hardware and Firmware Overview"** – Describes the MCP2030 Bidirectional Communication Demo Kit hardware and firmware.
- **Appendix A. "Schematic and Layouts"** – Shows the schematic and board layouts for the MCP2030 Bidirectional Communication Demo Kit.
- **Appendix B. "Bill of Materials (BOM)"** - Lists the parts used to build the demo boards that make up MCP2030 Bidirectional Communication Demo Kit.

MCP2030 Bidirectional Communication Demo Kit User's Guide

CONVENTIONS USED IN THIS GUIDE

This manual uses the following documentation conventions:

DOCUMENTATION CONVENTIONS

Description	Represents	Examples
Code (Courier font):		
Plain characters	Sample code Filenames and paths	#define START c:\autoexec.bat
Angle brackets: < >	Variables	<label>, <exp>
Square brackets []	Optional arguments	MPASMWIN [main.asm]
Curly brackets and pipe character: { }	Choice of mutually exclusive arguments; An OR selection	errorlevel {0 1}
Lowercase characters in quotes	Type of data	"filename"
Ellipses...	Used to imply (but not show) additional text that is not relevant to the example	list ["list_option...", "list_option"]
0xnnn	A hexadecimal number where n is a hexadecimal digit	0xFFFF, 0x007A
Italic characters	A variable argument; it can be either a type of data (in lowercase characters) or a specific example (in uppercase characters).	char isascii (char, ch);
Interface (Arial font):		
Underlined, italic text with right arrow	A menu selection from the menu bar	<i><u>File > Save</u></i>
Bold characters	A window or dialog button to click	OK, Cancel
Characters in angle brackets < >	A key on the keyboard	<Tab>, <Ctrl-C>
Documents (Arial font):		
Italic characters	Referenced books	<i>MPLAB[®] IDE User's Guide</i>

RECOMMENDED READING

It is recommended that you become familiar with the documents listed below, prior to using the MCP2030 Bidirectional Communication Demo Kit.

Telecontrolli Data Sheet, "AMHRRQ3-433" , www.telecontrolli.com, (DS.0015-1.pdf)

Telecontrolli Data Sheet, "AMHRR3-433", www.telecontrolli.com, (DS.0016-9.pdf)

Application Note AN710, "Antenna Circuit Design", (DS00710)

Application note describing LF antenna circuit design for RFID applications.

Application Note AN959, "Using the PIC16F639 MCU for Smart Wireless Communications" (DS00959)

Application note describing the PIC16F639 as a suitable microcontroller for bidirectional communications and low-frequency sensing applications.

Application Note AN1024, "PKE System Design Using the PIC16F639" (DS01024)

Application note describing the PIC16F639 for bidirectional communication applications.

PICkit™ 2 Microcontroller Programmer User's Guide (DS51553)

Consult this document for instructions on how to use the PICkit 2 Microcontroller Programmer hardware and software.

PIC12F635/PIC16F636/639 Data Sheet (DS41232)

Data sheet for the PIC12F635/PIC16F636/639 8/14-pin Flash-based, 8-bit CMOS microcontrollers with nanoWatt technology.

PIC18F2585/2680/4585/4680 Data Sheet (DS39625)

Data sheet for the PIC18F2585/2680/4585/4680 28/40/44-pin enhanced Flash microcontrollers with ECAN™ technology, 10-bit A/D and nanoWatt technology.

MCP2030 Data Sheet, "Three-Channel Analog Front-End Device" (DS21981)

Data sheet for the MCP2030 device.

TC4421/TC4422 Data Sheet, "High-Speed MOSFET Drivers" (DS21420)

Data sheet for the TC4421/TC4422 9A High-Speed MOSFET Driver. Gives an overview of the device including electrical characteristics.

MCP3421 Data Sheet, "18-Bit Delta-Sigma Analog-to-Digital Converter with I²C Interface and On-Board Reference" (DS22003)

Data sheet for the MCP3421 18-Bit Delta-Sigma Analog-to-Digital Converter.

THE MICROCHIP WEB SITE

Microchip provides online support via our web site at www.microchip.com. This web site is used as a means to make files and information easily available to customers. Accessible by using your favorite Internet browser, the web site contains the following information:

- **Product Support** – Data sheets and errata, application notes and sample programs, design resources, user's guides and hardware support documents, latest software releases and archived software
- **General Technical Support** – Frequently Asked Questions (FAQs), technical support requests, online discussion groups, Microchip consultant program member listing
- **Business of Microchip** – Product Selector Guide, latest Microchip press releases, listing of seminars and events, listings of Microchip sales offices, distributors and factory representatives

CUSTOMER SUPPORT

Users of Microchip products can receive assistance through several channels:

- Distributor or Representative
- Local Sales Office
- Field Application Engineer (FAE)
- Technical Support
- Development Systems Information Line

Customers should contact their distributor, representative or field application engineer for support. Local sales offices are also available to help customers. A listing of sales offices and locations is included in the back of this document.

Technical support is available through the web site at: <http://support.microchip.com>

DOCUMENT REVISION HISTORY

Revision A (December 2006)

- Initial Release of this Document.

Chapter 1. Quick Start

1.1 INTRODUCTION

This section provides the user a quick step-by-step instruction guide on how to set-up the MCP2030 Bidirectional Communication Demo Kit.

1.1.1 Transponder Unit

Connect power to the Transponder unit by inserting a 3V NiHM (CR2032) battery to the battery holder in the bottom side of the Transponder. When the Transponder is powered on, it is waiting for a 125 kHz low frequency (LF) command from the Base Station unit. On the PCB, there are three LF antenna coils: One large air-core coil on the bottom side and two ferrite-core coils on the top side. These three coils detect 125 kHz low frequency (LF) signals from x, y, and z directions. The Transponder also has a SAW (Surface Acoustic Wave) based UHF transmitter. A rectangular loop trace on the PCB is the UHF antenna. The Transponder has two LED diodes. A green LED (D6) will blink when the Transponder receives a valid LF command, and a red LED (D7) will blink when it transmitting an UHF response.

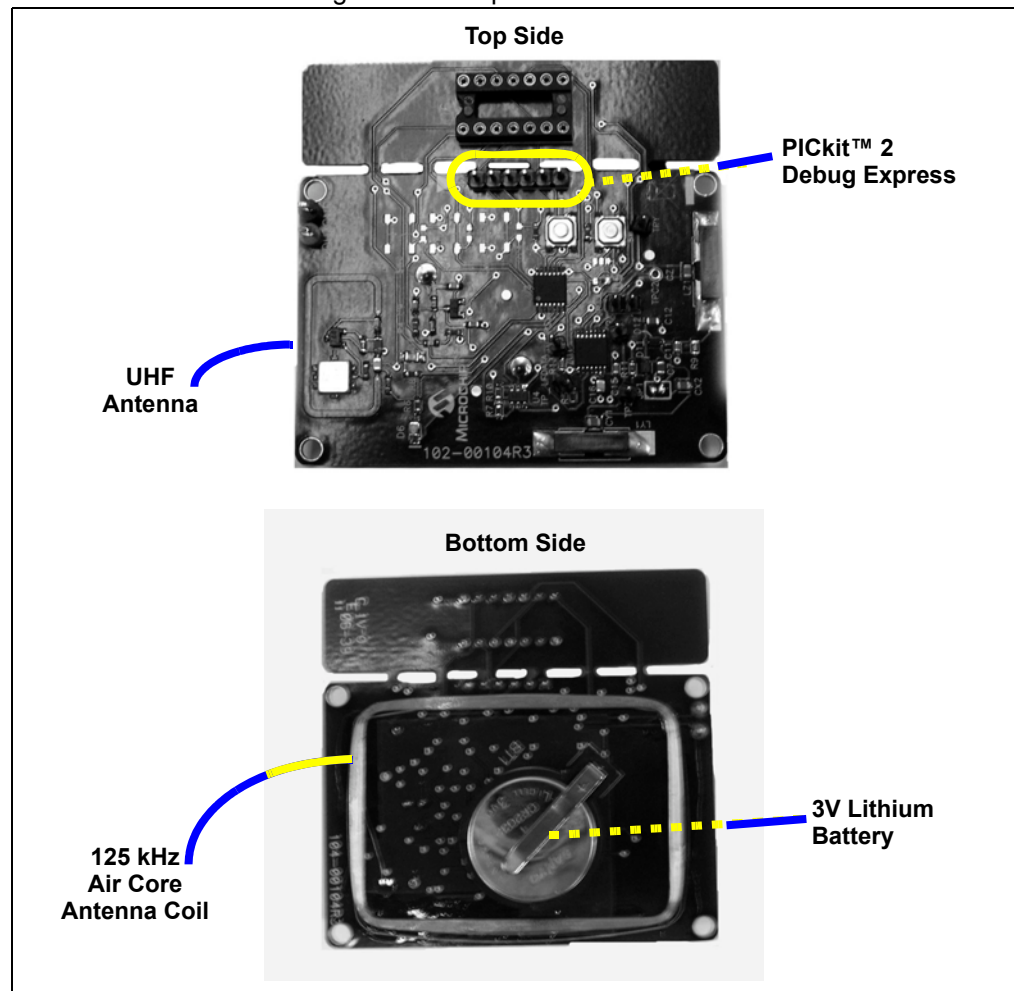

1.1.2 Base Station Unit:

Supply power to the Base Station unit with a 9V - 18V power supply. As soon as the power is supplied, the LED D2 will light on, and the unit starts transmitting an LF command. The unit also waits for the responses from the Transponder at any time, except during the transmission of the LF command. When the unit receives a valid response from the Transponder, the LED D3 will blink and the received Transponder ID and RSSI (Received Signal Strength Indicator) value will be displayed on the LCD.

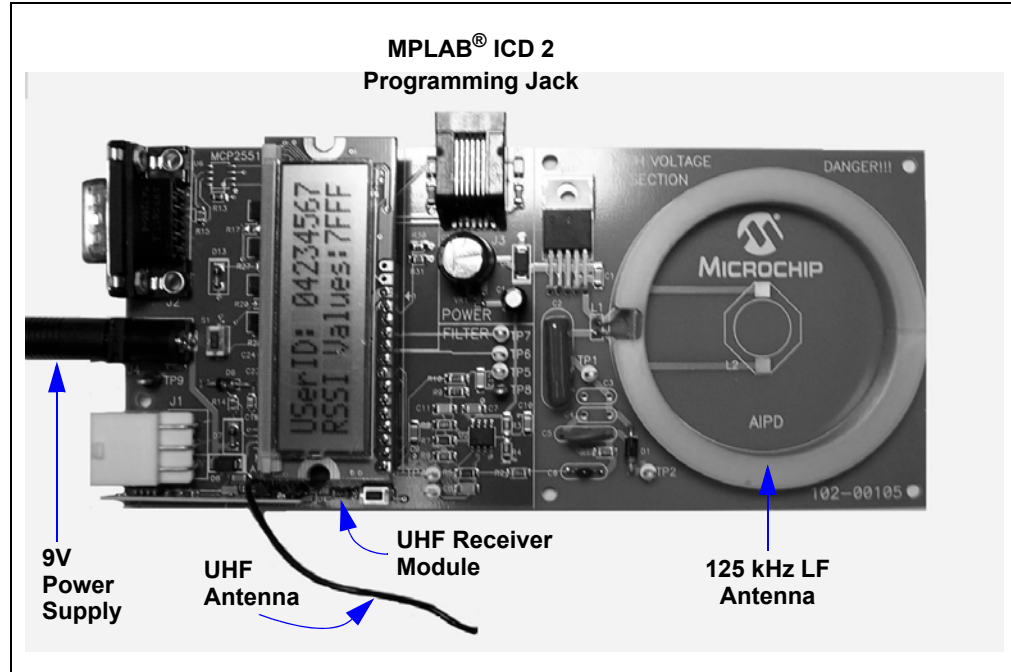

1.1.3 When both the Base Station and Transponder units are powered-on:

When the two units are powered-on, they will communicate by themselves. The Base Station sends a 125 kHz LF command and the Transponder responds to the command. When the Transponder is placed within about 2 meters to the Base Station unit, the two units may have a successful communication with each other and the Base Station unit will display the received Transponder ID and RSSI value on the LCD. This is called a bidirectional communication. User can test the RSSI by moving the Transponder within the Base Station's LF field. The RSSI value will increase as the Transponder comes closer to the Base Station antenna and decrease as moves away from it. The two units are communicating with each other as long as the boards are powered. You can also test one directional communication from the Transponder to the Base Station unit by pressing button switch (SW3 or SW4) on the Transponder. The range of the one directional communication is about 20 meters.

This MCP2030 Bidirectional Communication Demo Kit shows you how to create a smart hands-free bidirectional communication system using the stand-alone MCP2030 and microcontroller. All MCU firmware used for both the Transponder and Base Station units are included in the CD ROM provided with the MCP2030 Bidirectional Communication Demo Kit. The user can easily modify the firmware for their own applications.

Chapter 2. System Overview

2.1 OVERVIEW

This section describes how to use the MCP2030 Bidirectional Communication Demo Kit.

The MCP2030 Bidirectional Communication Demo Kit consists of two Transponders and a Base Station unit. The Transponder consists of an MCP2030 (stand-alone three-axis analog front-end device), a PIC16F636, and an MCP3421 (18-bit delta-sigma analog-to-digital converter). Unlike the existing PKE Reference Design System (P/N: APGRD001) from Microchip Technology Inc., this Transponder uses stand-alone devices for the bidirectional passive keyless entry (PKE) operation. This system also demonstrates the received signal strength indicator (RSSI) function using the MCP3421 delta-sigma ADC. When the Transponder receives a Base Station command, it transmits its ID and sampled RSSI value. By monitoring or mapping the RSSI values, the user can estimate location or motion of the transponder with respect to the Base Station unit. For example, for the automotive passive keyless entry (PKE) applications, the Base Station mounted inside the vehicle can determine whether the transponder is located inside or outside of the vehicle, or in the front or back seat in the vehicle.

The Base Station unit consists of a PIC18F4680, a low frequency (LF) power amplifier, an LF receiver section, a 434 MHz UHF receiver module, an LCD display, and CAN/LIN transceiver sections. The components in the LF receiver section and the CAN/LIN transceiver sections are populated on the PCB for future use, but their functions are not utilized for this demo version. Any user who needs these features can contact Microchip Technology Inc. for further information.

The MCP2030 Bidirectional Communication Demo Kit has been designed for easy modification by customers. The firmware of both the Transponder and Base Station units can be easily modified using the MPLAB[®] in-circuit serial programmers.

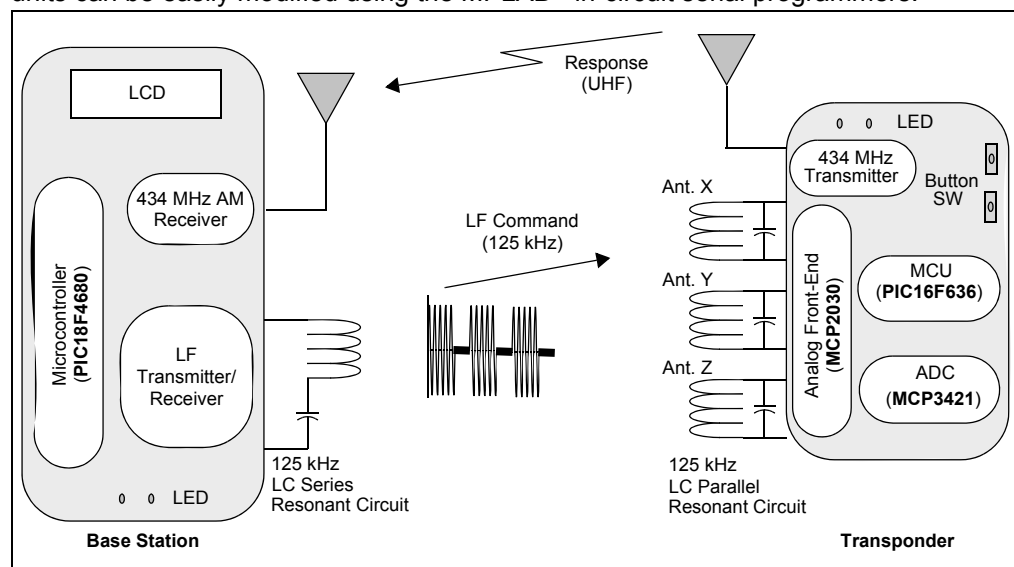

FIGURE 2-1: MCP2030 Bidirectional Communication System Block Diagram.

2.2 OPERATIONAL OVERVIEW

When the MCP2030 Base Station unit is powered on using a 9 V power supply and the MCP2030 transponder demo board is powered-on using a 3V lithium battery, the system works as follows:

(a) The Base Station unit transmits an LF command. Requesting the Transponder's ID and RSSI data.

(b) When the Transponder receives the LF command, it transmits its 32-bit ID and RSSI data via the UHF (434 MHz) link.

(c) When the Base Station unit receives the response from the Transponder, it displays the Transponder ID and RSSI value on the LCD.

(d) The system repeats steps (a) through (c) as long as the power is supplied.

(e) If the button switch SW3 or SW4 on the Transponder is pressed, the Transponder transmits the button data (SW3: Unlock door, SW4: Lock door). The Base Station unit displays the button message on the LCD.

Figure 2-2 shows the communication sequence between the Base Station and the Transponder units. Figure 2-3 shows the Base Station's LF command and the demodulated data by the MCP2030.

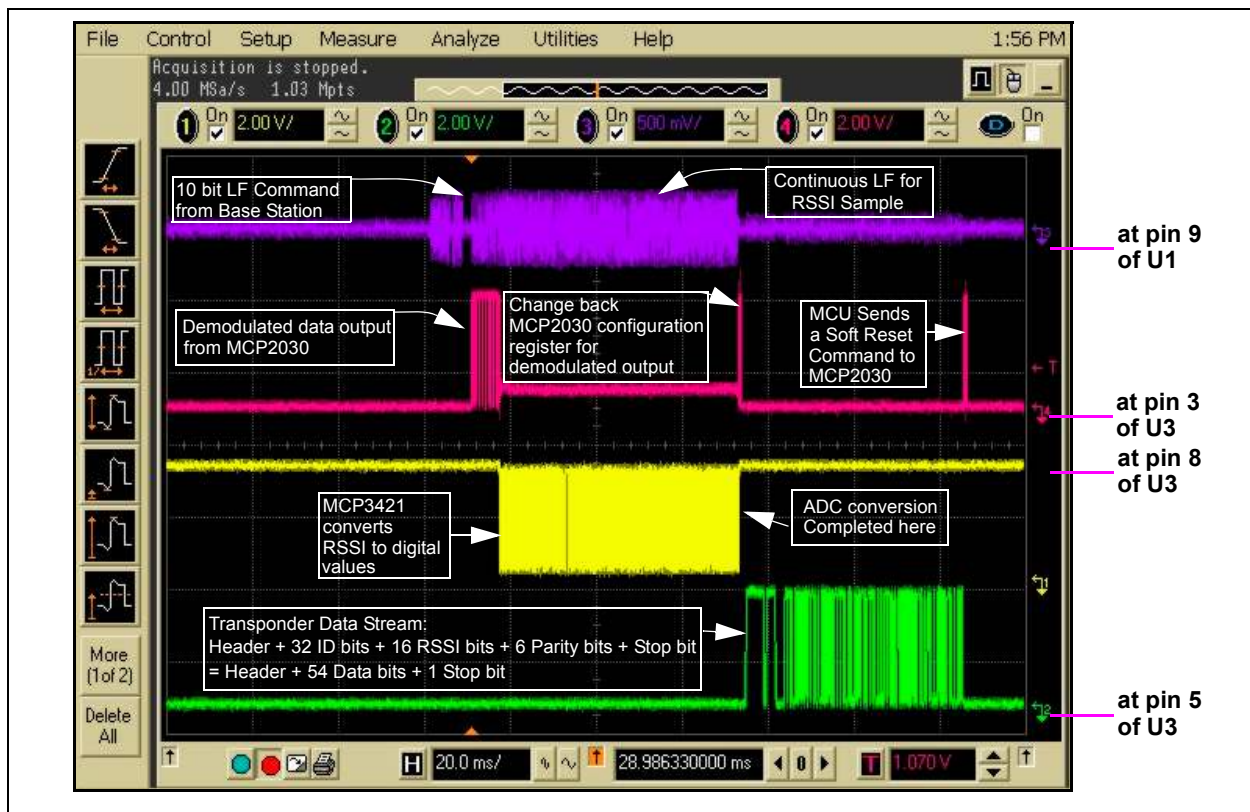

FIGURE 2-2: Base Station Command and Transponder Response.

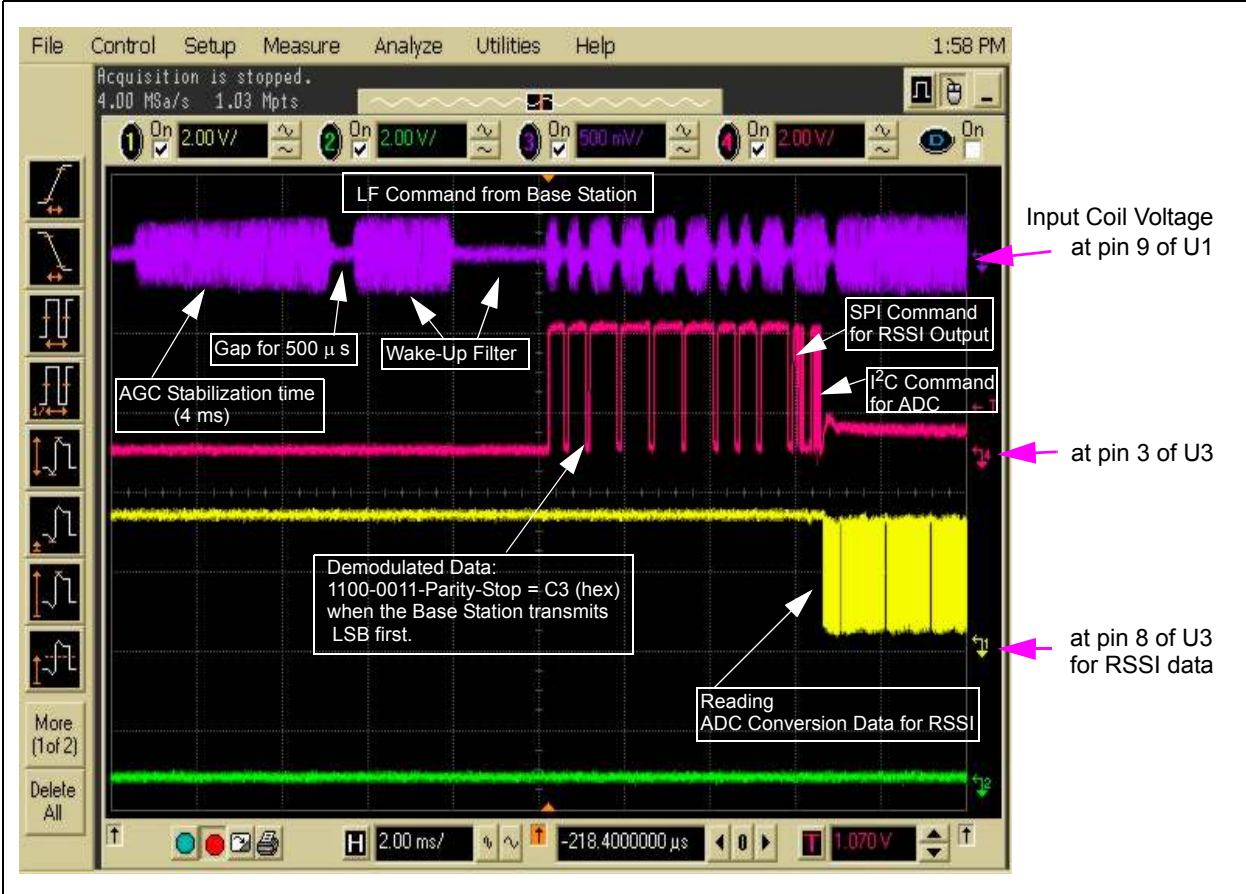

FIGURE 2-3: Received Base Station Command and Demodulated Data.

2.3 FEATURES

2.3.1 MCP2030 Base Station Unit

Features of the Base station Unit are as follows:

- Send an LF command continuously requesting the Transponder ID and RSSI data
- Display the received Transponder responses
- MPLAB[®] ICD 2 In Circuit Serial Programming[™] (ICSP[™])

Note: LF talkback, CAN and LIN feature support: Components are populated, but not used for this demo version.

2.3.2 MCP2030 Transponder Unit

Features of the Transponder are as follows:

- Detect the LF command
- Sample the RSSI values
- Transmit 32 bit Transponder ID and 16 bit RSSI data
- Two push button switches (SW3 and SW4) for Unlock and Lock door commands
- Two LED outputs:
 - Green LED that blinks when the Transponder receives a valid LF command.
 - Red LED that blinks when the Transponder is transmitting RF data or receiving invalid LF command.

Chapter 3. Hardware and Firmware Overview

3.1 INTRODUCTION

The following section provides an overview of the hardware and MCU firmware algorithm used in the MCP2030 Bidirectional Communication Demo Kit.

3.2 MCP2030 BASE STATION DEMO BOARD

3.2.1 Technical Specifications

Normal Operating Voltage:	9 - 18V, Current Rating > 500 mA
LF Frequency (LF Command Frequency)	125 kHz
UHF AM Receiving Frequency:	433.92 MHz
Liquid Crystal Display (LCD):	2x16 characters
Communication Protocols:	See Figure 2-2 , Figure 3-1 , Figure 3-2

3.2.2 Microcontroller (PIC18F4680)

The PIC18F4680 is used in this unit. The MCU provides an 125 kHz PWM for LF command and decodes incoming Transponder responses. If the response is valid, it displays the received data on the LCD and also blinks the LED D3. The PIC18F4680 has both a CAN controller and a LIN compatible EUSART features. The CAN and LIN transceiver components are populated on the Base Station Demo Board, but their functions are not implemented for this demo version.

3.2.3 433.92 MHz UHF Receiver Module

The Base Station Demo Board uses a 433.92 MHz AM super-regenerative compact hybrid receiver module. The AM UHF receiver receives the responses from the Transponder. The receiver has very high frequency stability over a wide operating temperature and tolerance of mechanical vibrations or manual handling. The AM receiver module has about -90 dBm of input sensitivity. The user can use their own receiver module of any frequency of interest as long as the frequency and modulation/demodulation method matches with those of the transmitter on the Transponder.

3.2.4 LCD

A standard 16 pin 2x16 monochromes LCD is used to display the response from the Transponder.

3.2.5 125 kHz Low Frequency Command Initiator

The 125 kHz PWM from the PIC18F4680 is power boosted by the MOS FET driver (TC4422). The PWM square pulse becomes a sine wave as the current passes through the LC series resonant circuit formed by L1 and C2, C3, and C4 on the Base Station Demo Board. The current that is passing through the L1 generates a magnetic field. When this magnetic field transmitted from the Base Station Demo Board is passing through the Transponder Demo Board's antenna coil, it produces a voltage. This voltage is detected by the MCP2030 LF front-end device and the information carried on the voltage is processed by the PIC16F636 microcontroller on the transponder. See **Recommended Reading** for more details of the near-field magnetic coupling principles.

3.2.6 Power

Power can be supplied through J1 power jack. The voltage should be in the range of 9 - 18 VDC with a current rating greater than 500 mA.

3.2.7 MCU FIRMWARE ALGORITHM

The bidirectional communication method between the Base Station Demo Board and Transponder Demo Board is shown in [Figure 2-2](#). The Base Station Demo Board sends an LF command, receives the responses from the Transponder Demo Board, and displays the received responses on the LCD. The Base Station Demo Board repeats the transmitting and receiving functions as long as its power supply is connected. [Figure 3-1](#) shows the LF command data format and waveform. The receiving data format is shown in [Figure 3-5](#). The MCU firmware for the communication algorithm is included on the MCP2030 Bidirectional Communication Demo Kit CD ROM.

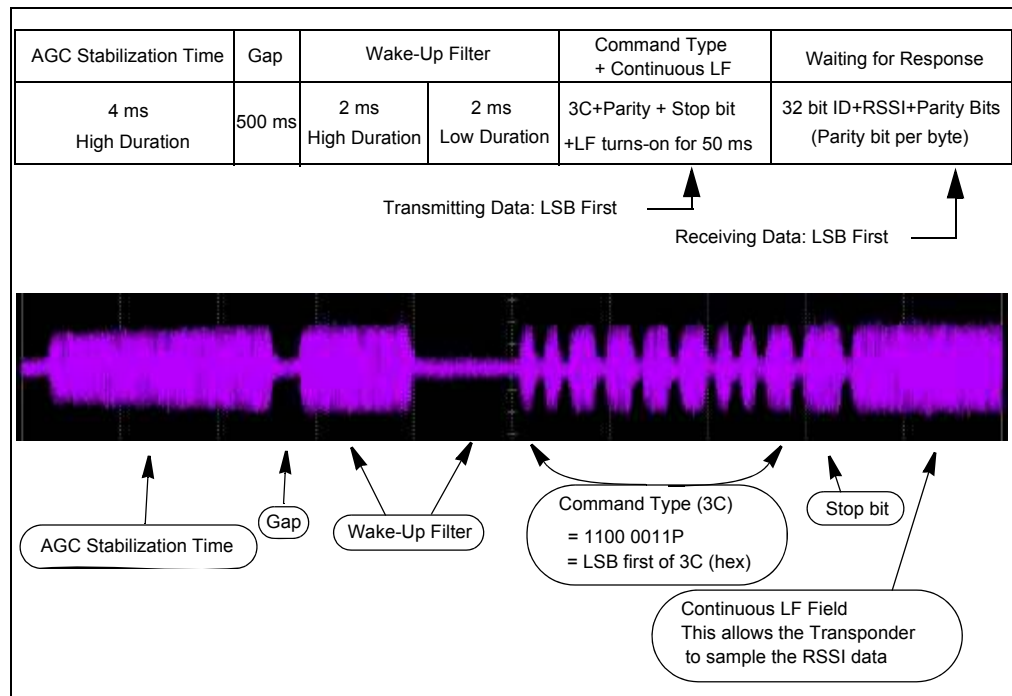

FIGURE 3-1: Base Station Demo Board LF Command Data Format.

MCP2030 Bidirectional Communication Demo Kit User's Guide

The LF command Base Station Demo Board consists of a 125 kHz carrier modulated as follows:

- 1: 4 ms ON for AFE's AGC stabilization.
- 2: 500 μ s OFF.
- 3: 2 ms ON followed by a 2 ms OFF (AFE's output enable filter). This pattern is dependant on the configuration setting of the receiving AFE.
- 4: 10 bit of command type (3C), parity, and Stop bit. The bits are transmitted Least Significant bits (LSb) first. The data is encoded with PWM method. (see [Figure 3-2](#)).
- 5: 50 ms ON for RSSI sample.
- 6: Waiting for a valid response from the Transponder.

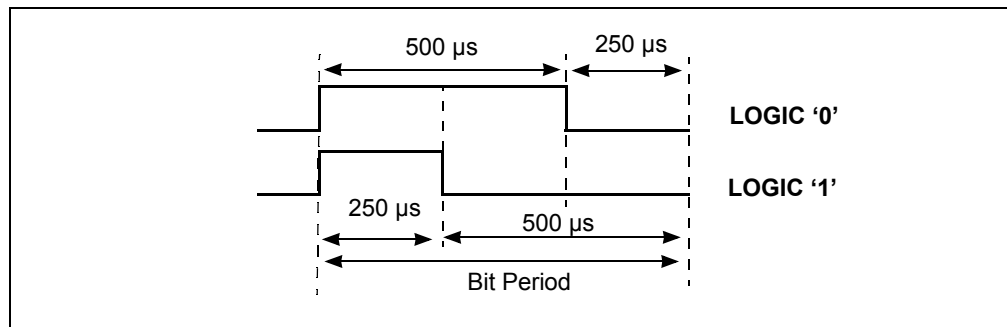

FIGURE 3-2: PWM Data Encoding Format.

3.3 MCP2030 TRANSPONDER DEMO BOARD

3.3.1 Technical Specifications

LF Input Frequency:	125 kHz
LF Input Modulation Format:	Amplitude Modulation
Encoding Method:	Pulse Width Modulation (PWM)
Operating Voltage:	2 - 3.6V. See Note 1
LF Input Sensitivity:	~3 mVPP. See Note 2
LF Detection Range:	Up to 3 meters
Transmitting Frequency:	433.92 MHz
UHF Range:	Up to ~ 20 meters
Bidirectional Communication Range	Up to 3 meters

Note 1: The minimum requirement for V_{DD} of the MCP3421ADC is 2.7V. For the V_{DD} less than 2.7V, the ADC result of the RSSI value may not be stable.

2: Contact Microchip Technology Inc. for the device option with higher than 3 mVpp sensitivity.

3.3.2 Microcontroller (PIC16F636)

The Transponder Demo Board uses a PIC16F636 microcontroller. This MCU is the same device that is used inside the PIC16F639 which is a dual die package device (PIC16F639 = PIC16F636 die + MCP2030 die in a single 20-pin package). The MCU interfaces with the MCP2030 stand-alone analog front-end device for LF communications and the MCP3421 delta-sigma analog-to-digital converter for RSSI data conversion. When the MCU is first powered-up, it writes the MCP2030 configuration registers and also writes the configuration register of the MCP3421 ADC (for 16 bit and one-shot mode). The MCP3421 stays in a low power standby mode after one conversion. The MCU also stays in a low power sleep mode while the MCP2030 is looking for a valid LF command.

The MCU is waken up by the demodulated output from the MCP2030 or by a button switch event (SW3 and SW4). The MCU decodes the demodulated output data from the MCP2030. If the data is a valid command, it blinks the green LED (D6) and reads the RSSI value by controlling the MCP3421 ADC. Once the RSSI value is acquired, the MCU feeds the transponder ID and the RSSI data into the 433.92 MHz UHF transmitter. The transmitted data from the UHF transmitter is detected by the RF receiver in the Base Station Demo Board and the data is displayed on the LCD.

When a button switch is pressed, the MCU feeds a corresponding data into the UHF transmitter. The red LED (D7) blinks each time the transponder transmits the UHF response. The red LED also blinks when the transponder receives invalid data.

3.3.3 Three-Input LF (125 kHz) Front-End (MCP2030)

The MCP2030 detects the Base Station Demo Board's LF command using three LF antenna coils that are mounted on the Transponder Demo Board PCB. The Configuration registers of the MCP2030 are configured by the MCU when the Transponder Demo Board is powered up the first time, and are re-configured during operation. The MCU controls the MCP2030 for two different outputs: (a) Demodulated data and (b) Received Signal Strength Indicator output (RSSI). When it is detecting input signals, the device is configured for the demodulated data output. Once the MCU finds a valid LF command, then the MCU re-configures the MCP2030 for the RSSI output. In this case, the MCP2030 outputs the RSSI current that is proportional to the LF input signal

strength. This current output is fed into a resistor and the voltage across the resistor is fed into the MCP3421 ADC input pin. The converted 16-bit ADC output is then fed into the MCU.

The function of the MCP2030 is controlled by its configuration register settings. Highly intelligent signal detection and response (bidirectional communications) is possible by utilizing the MCP2030 configuration register settings. The user can easily change or modify the included firmware for different settings of the MCP2030 configuration registers for their own applications.

3.3.4 UHF Transmitter (433.92 MHz)

A 433.92 MHz UHF transmitter is used to transmit the Transponder Demo Board data to the Base Station Demo Board. The UHF transmitter is based on a surface acoustic wave (SAW) resonator. The transmitter is turned on during the high duration of the data and off during the low duration of the bit data.

Note: The design and layout of this transmitter is not sufficient to ensure compliance with EC or FCC regulations.

3.3.5 Analog-to-Digital Converter (MCP3421)

The Transponder Demo Board uses an MCP3421 ADC to convert the analog RSSI output of the MCP2030 to digital data. The MCP3421 is a delta-sigma analog-to-digital converter with 12, 14, 16, and 18 bit mode options. In this demo board, the converter is configured for the 16 bit and one-shot mode. When the transponder is powered-up, the MCU sends an I²C write command to the MCP3421 for one-shot mode and 16 bit conversion. After one conversion, the device stays in a low power standby mode. During this mode, the device draws only about 1 μ A. When the MCP2030 analog front-end device receives a valid Base Station command, then the MCU sends an I²C read command to the MCP3421 ADC for the analog-to-digital data conversion. At this moment, the Base Station Demo Board transmits a continuous LF signal for about 50 ms allowing the MCP2030 to collect the RSSI values. The RSSI voltage across the RSSI load resistor is fed into the MCP3421 input pin. After the MCU sends the I²C read command, it is waiting for the MCP3421 to complete the conversion by checking the RDY bit of the MCP3421 output. In typical operation, it takes about 50 ms to complete a 16 bit conversion. See [Figure 2-2](#) and [Figure 2-3](#) for more information on the ADC operation.

TABLE 3-1: PIC16F636 I/O CONNECTIONS

PORT Pin	Function	Notes
Port A		
RA0	Switch 4	ICSP™ Data
RA1		ICSP Clock
RA2	Switch 3	
RA3		ICSP MCLR
RA4	LFDATA Input from MCP2030, SPI SDIO for MCP2030	
RA5	SPI SCLK Output for MCP2030	
Port C		
RC0	RF Active LED	
RC1	SPI CS output for MCP2030	
RC2	I ² C SDA for MCP3421	
RC3	I ² C SCL for MCP3421	
RC4	Valid LFDATA Input Indicator LED	
RC5	RF Data Out	

3.3.6 Programming of the Transponder

The Transponder Demo Board has a Programming Connector (J1) for In-Circuit Serial Programming™ (ICSP™). See [Figure 3-3](#) for the J1 Programming Connector. The transmitter can therefore be re-programmed using the PICkit® 2 (or PICkit® 1) without removing the microcontroller from the board.

MCLR	1
V _{CC}	2
V _{SS}	3
ICSPDAT	4
ICSPCLK	5
no connection	6

FIGURE 3-3: J1 Programming Connector.

3.3.7 Power

The Transponder Demo Board is powered by a standard Lithium 3V coin cell battery.

3.3.8 Microcontroller Firmware Algorithm

When the Transponder Demo Board is powered on, the PIC16F636 (MCU) programs the configuration registers of the MCP2030 and also the configuration register of the MCP3421 (ADC). After these set-up procedures, the MCU enters a low-power sleep mode while the MCP2030 is looking for a valid LF command. The MCU is waken-up by the demodulated output from the MCP2030 or button switch event. If the MCU receives a valid demodulated data from the MCP2030, then it transmits its 32 bit transponder ID followed by the 16 bit received signal strength indicator (RSSI) data. If the MCU is waken-up by a switch event (SW3 and SW4), it transmits the corresponding switch event data. The data is always attached to the header (See [Figure 3-5](#)). The Transponder ID is set to "04234567" and programmed in the EEPROM. The RSSI data is proportional to the LF signal strength. Therefore, the RSSI data increases as the Transponder Demo Board comes closer to the Base Station Demo Board. The Transponder Demo Board transmits each byte LSB first and also transmits a parity bit at end of each byte. See [Figure 3-5](#) for more details of the Transponder Demo Board data stream. [Figure 3-4](#) shows the firmware flow chart.

The MCU firmware is included in the MCP2030 Bidirectional Communication Demo Kit CD ROM.

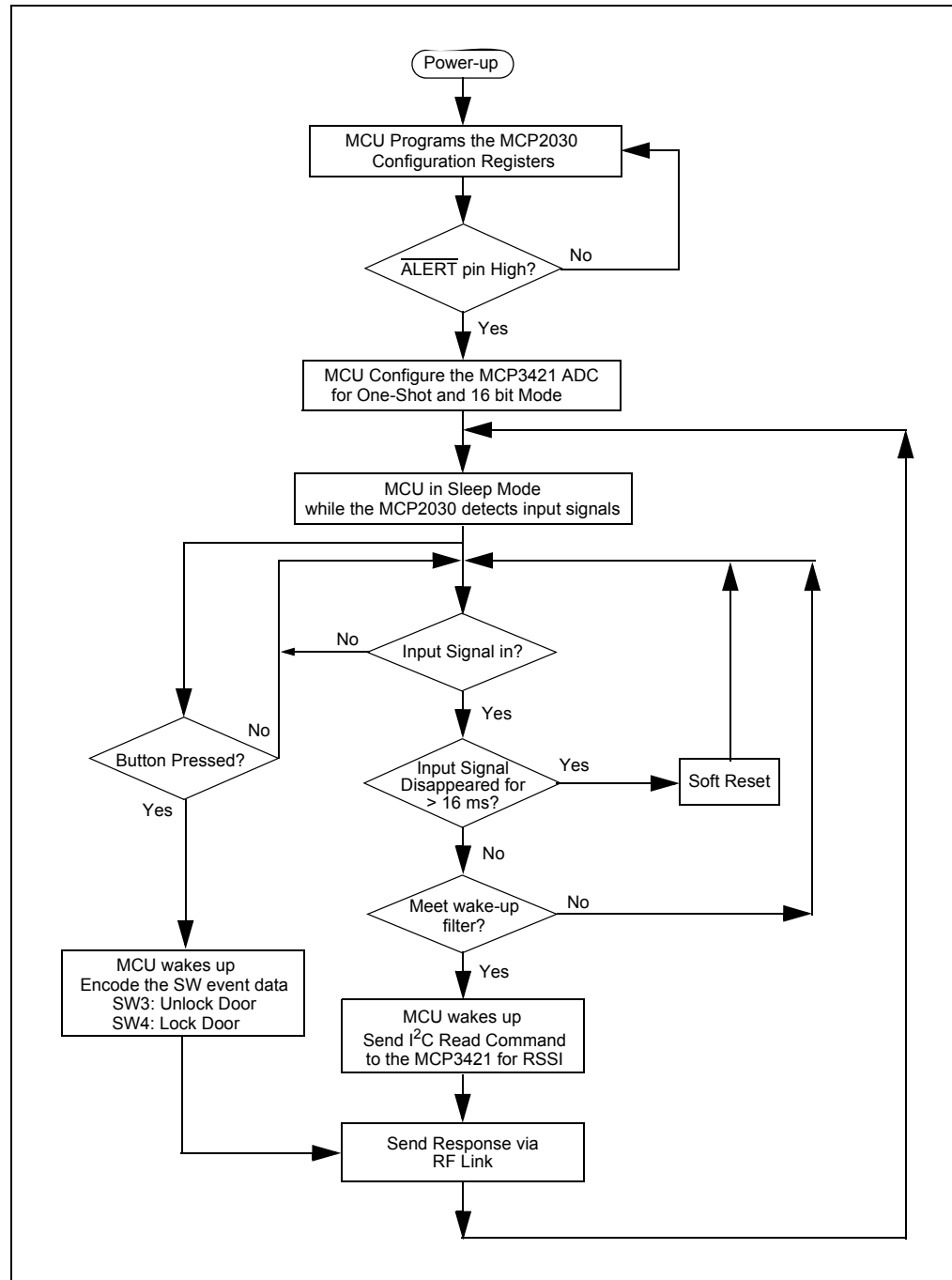

FIGURE 3-4: Communication Flow-Chart of the Transponder Demo Board.

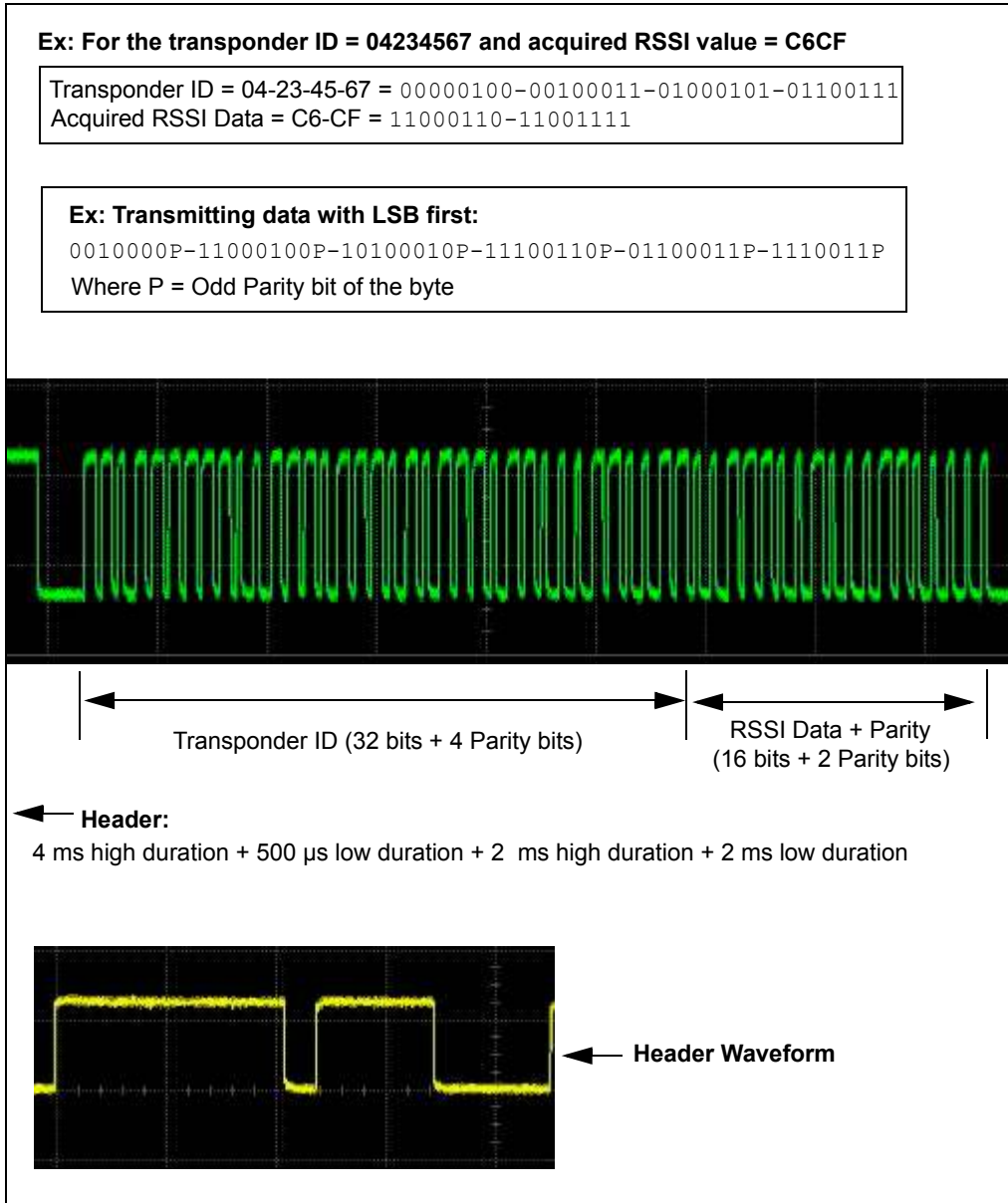

FIGURE 3-5: EXAMPLE: Transponder Response for ID and RSSI



MCP2030 BIDIRECTIONAL COMMUNICATION DEMO KIT USER'S GUIDE

Appendix A. Schematic and Layouts

A.1 INTRODUCTION

This appendix contains the schematics and PCB layouts for the MCP2030 Bidirectional Communication Demo Kit. This Appendix includes:

- Transponder Demo Board - Schematic (102-00104)
- Transponder Demo Board - Top Layer (with silk screen)
- Transponder Demo Board - Bottom Layer
- Base Station Demo Board - Schematic (Page 1) (102-00105)
- Base Station Demo Board - Schematic (Page 2) (102-00105)
- Base Station Demo Board - Top Layer (with silk screen)
- Base Station Demo Board - Bottom Layer

MCP2030 Bidirectional Communication Demo Kit User's Guide

A.2 TRANSPONDER DEMO BOARD - SCHEMATIC

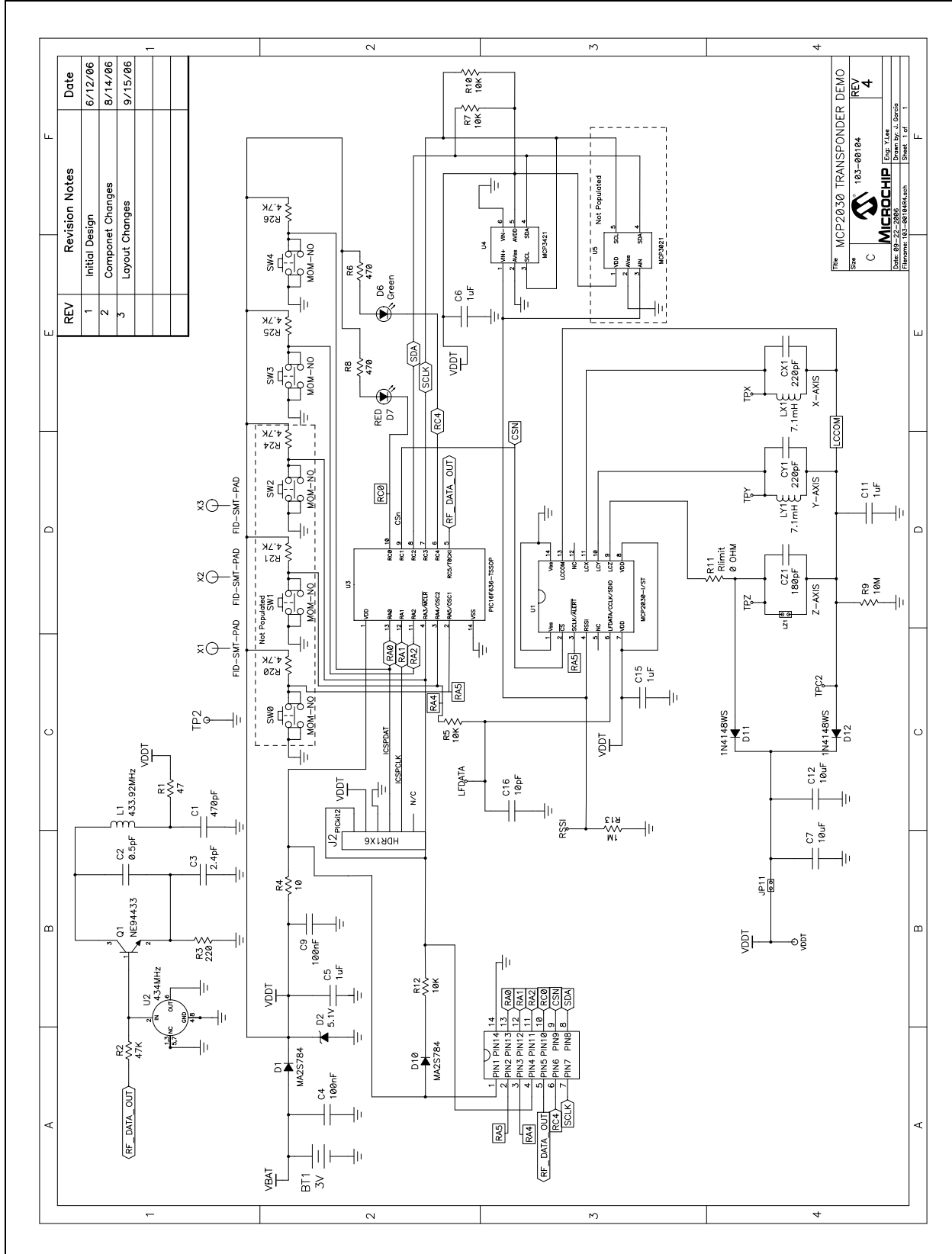

A.3 TRANSPONDER DEMO BOARD - TOP LAYER AND SILK SCREEN

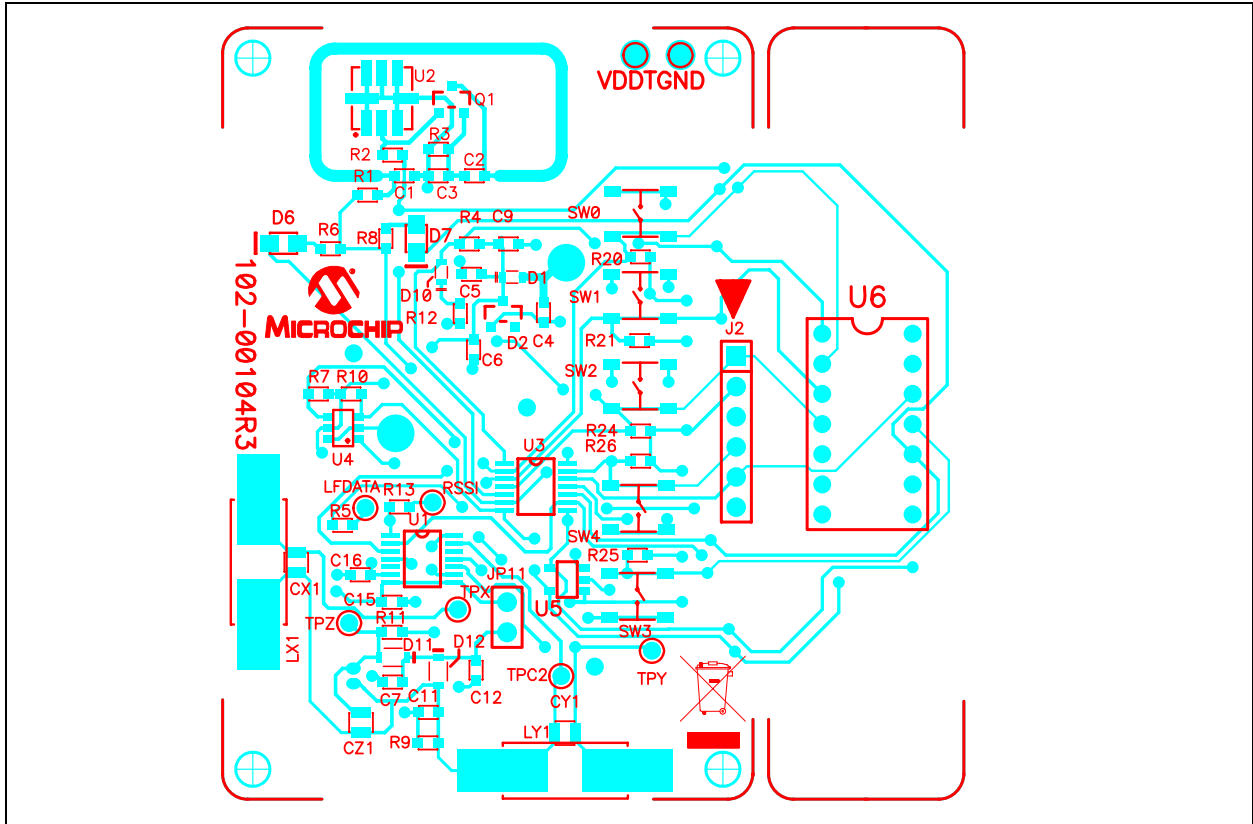

A.4 TRANSPONDER DEMO BOARD - BOTTOM LAYER

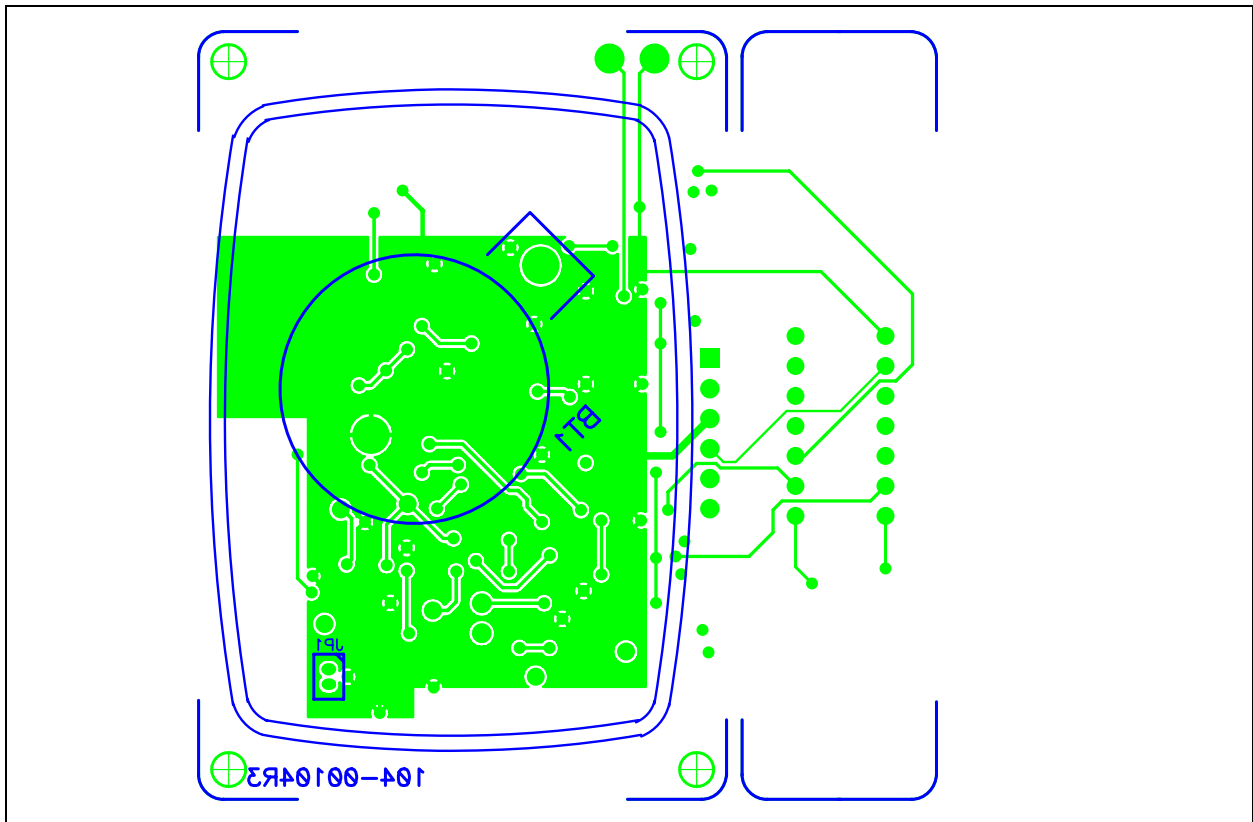

A.5 BASE STATION DEMO BOARD - SCHEMATIC (PAGE 1)

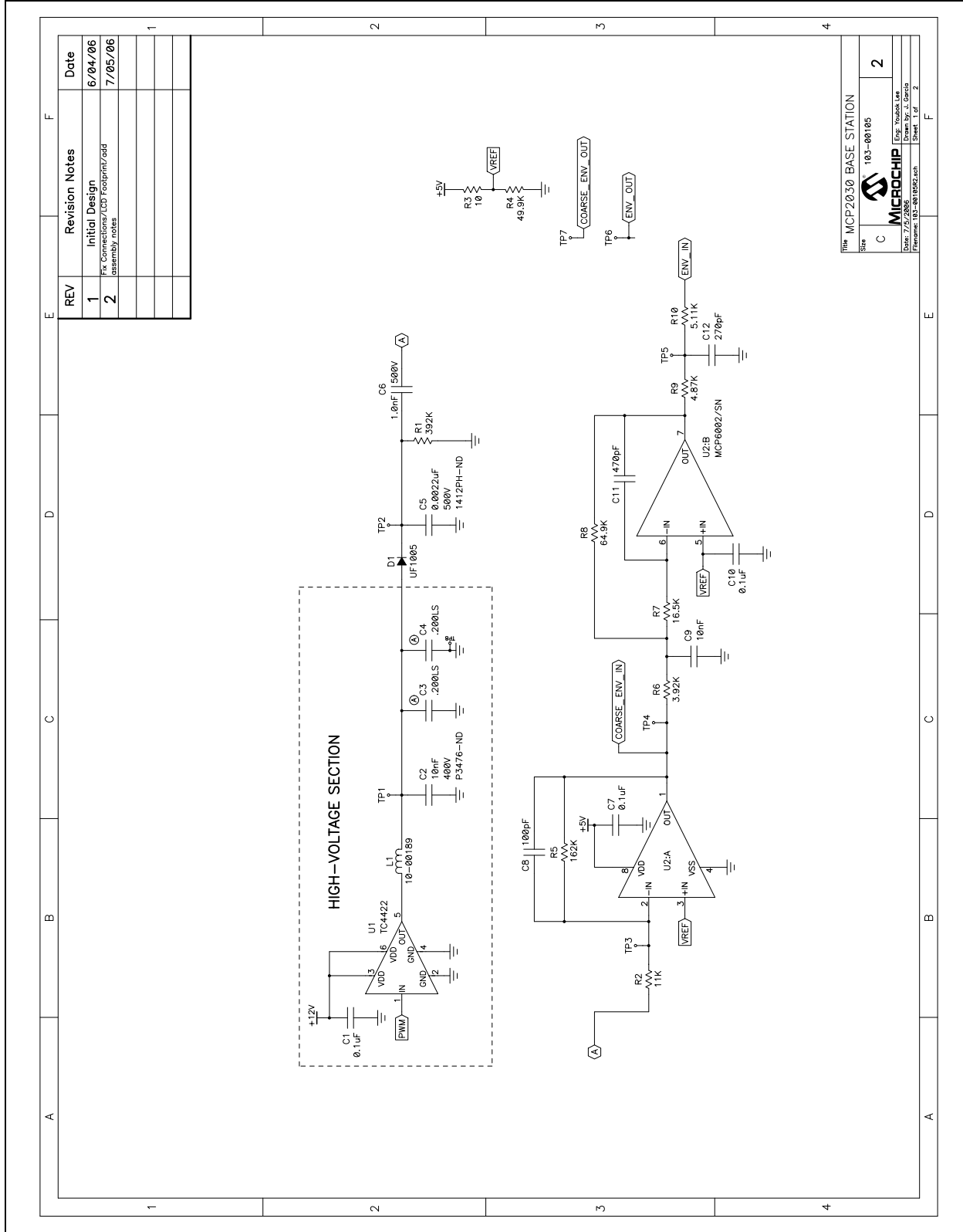

MCP2030 Bidirectional Communication Demo Kit User's Guide

A.6 BASE STATION DEMO BOARD - SCHEMATIC (PAGE 2)

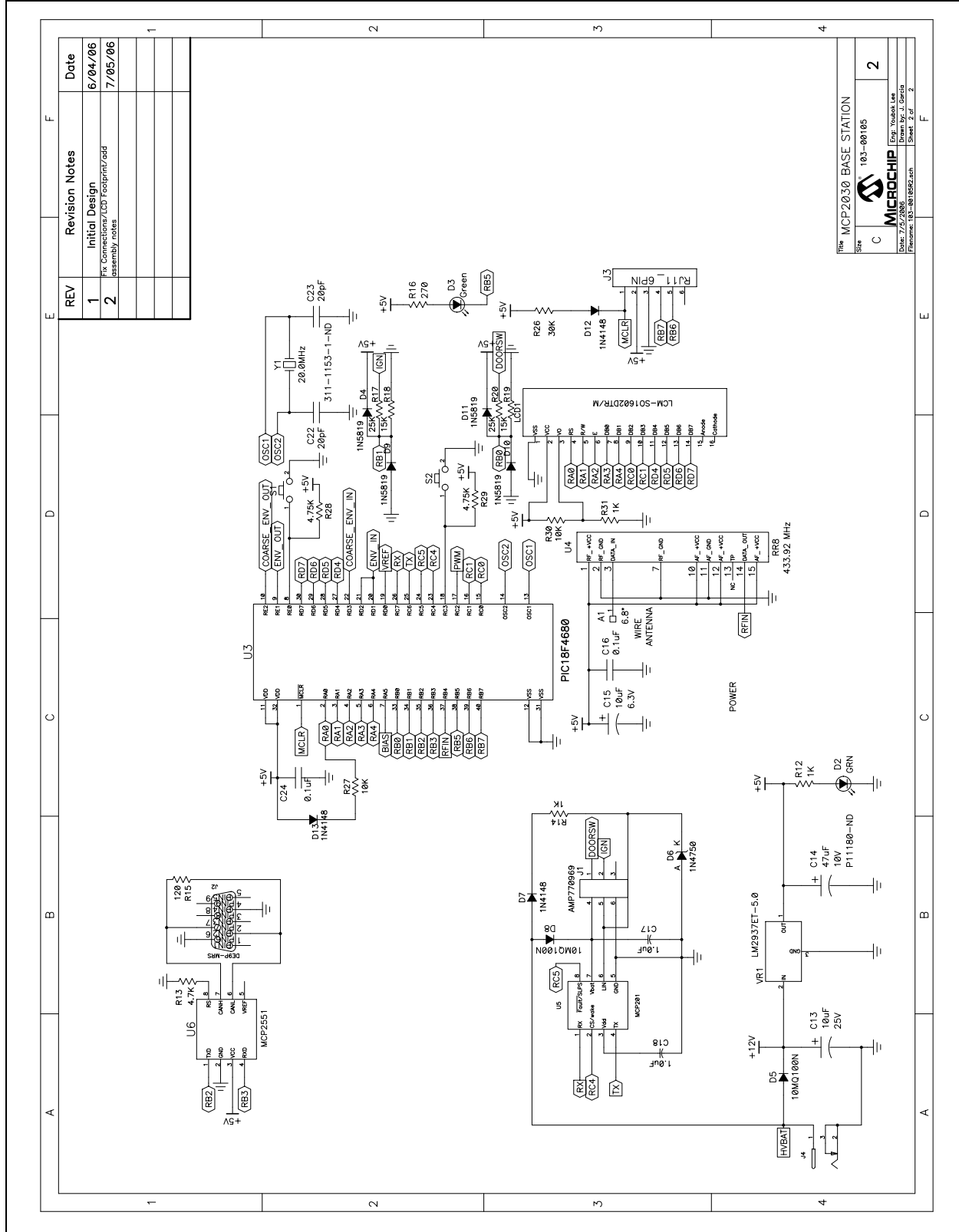

MCP2030 Bidirectional Communication Demo Kit User's Guide

A.7 BASE STATION DEMO BOARD - TOP LAYER AND SILK SCREEN

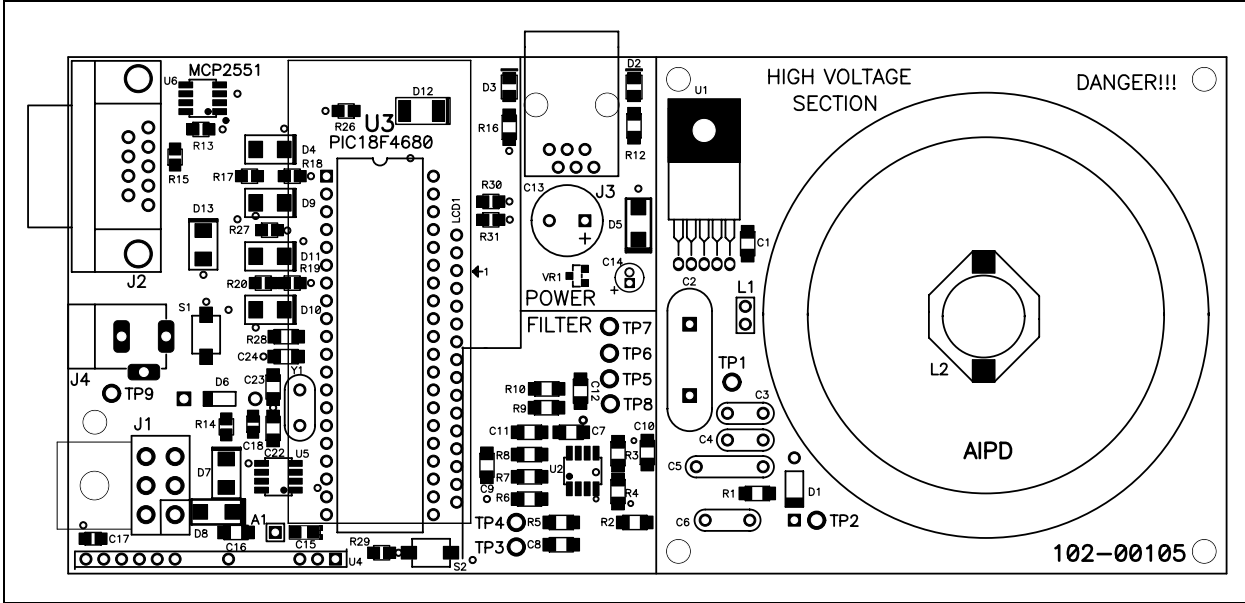

A.8 BASE STATION DEMO BOARD - BOTTOM LAYER

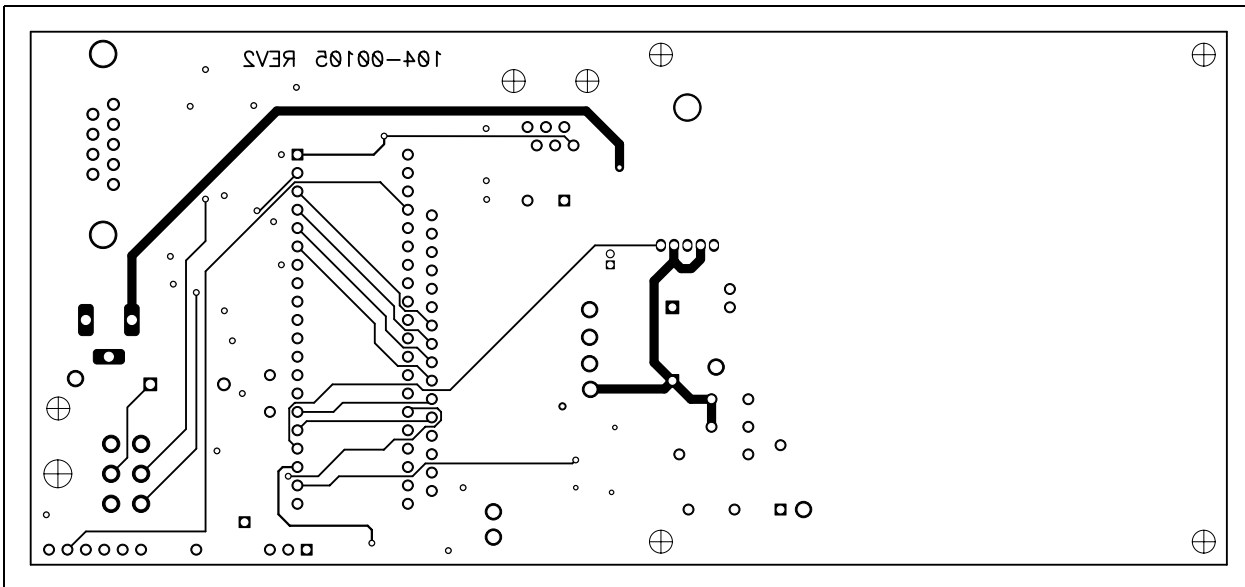



MCP2030 BIDIRECTIONAL COMMUNICATION DEMO KIT USER'S GUIDE

Appendix B. Bill of Materials (BOM)

B.1 INTRODUCTION

This appendix contains the bill of materials of the MCP2030 Bidirectional Communication Demo Kit. This Appendix includes:

- Transponder Demo Board - Bill of Materials
- Base Station Demo Board - Bill of Materials

TABLE B-1: TRANSPONDER DEMO BOARD - BILL OF MATERIALS

Qty	Reference Designator	Description	Manufacturer	Part Number
1	BT1	HOLDER BATTERY COIN 20MM 1-CELL	Keystone Electronics®	103
1	C1	CAP CERAMIC 470PF 50V NP0 0603	Panasonic® - ECG	ECJ-1VC1H471J
1	C2	CAP 0.5PF 50V CERAMIC 0603 SMD	Panasonic - ECG	ECJ-1VC1H0R5C
1	C3	CAP CERAMIC 2.4PF 50V C0G 0603	Rohm	MCH185A2R4CK
2	C4, C9	CAP .10UF 16V CERAMIC X7R 0603	Kemet® Electronics Corp	C0603C104K4RACTU
4	C5, C6, C11, C15	CAP 1UF 16V CERAMIC F 0603	Panasonic - ECG	ECJ-1VF1C105Z
2	C7, C12	CAP CERAMIC 10UF 6.3V X5R 0603	Panasonic - ECG	ECJ-1VB0J106M
1	C16	CAP CERM 10PF 10% 100V NP0 0603	AVX Corporation	06031A100KAT2A
1	Coin Battery	BATTERY LITHIUM COIN 3 VOLT 20MM	Energizer Battery Company	CR2012
2	CY1, CX1	CAP CERAMIC 220PF 50V 0603 SMD	Panasonic - ECG	ECJ-1VC1H221J
1	CZ1	CAP CERAMIC 180PF 50V 0603 SMD	Panasonic - ECG	ECJ-1VC1H181J
2	D1, D10	DIODE SCHOTTKY 30V 100MA SS-MINI	Panasonic - SSG	MA2S78400L
1	D2	DIODE ZENER 5.1V 0.35W SOT-23	Fairchild Semiconductor®	BZX84C5V1
1	D6	LED GREEN CLEAR 0805 SMD	LITE-ON INC	LTST-C170GKT
1	D7	LED RED CLEAR 0805 SMD	LITE-ON INC	LTST-C170CKT
2	D11, D12	DIODE SWITCH 75V 200MW SOD323	Diodes Inc	1N4148WS-7-F
1	J2	LOW PROFILE, SOLDER TAIL HEADER, .1" ST MALE, 1RW, 6PIN,	—	—
1	JP11	HEADER, .1" ST MALE, 1RW, 2PIN, (10) .025" PST, .23GOLD TAIL	—	—
1	JP11 Shunt	SHUNT, SHORTING BLOCKS, BLK, OPEN	JAMECO VALUEPRO	7600-B-R
2	LY1, LX1	INDUCTOR, RFID TRANSPONDER	Coilcraft	4308RV-715X_LB
1	LZ1	Precision wound Air Coils Part will be Provided	—	—
1	Q1	TRANSISTOR NPN OSC FT=2GHZ SOT23	NEC	NE94433-T1B-A
1	R1	RES 47.5 OHM 1/10W 1% 0603 SMD	Panasonic - ECG	ERJ-3EKF47R5V
1	R2	RES 47.5K OHM 1/10W 1% 0603 SMD	Panasonic - ECG	ERJ-3EKF4752V

Note 1: The components listed in this Bill of Materials are representative of the PCB assembly. The released BOM used in manufacturing uses all RoHS-compliant components

MCP2030 Bidirectional Communication Demo Kit User's Guide

TABLE B-1: TRANSPONDER DEMO BOARD - BILL OF MATERIALS (CONTINUED)

Qty	Reference Designator	Description	Manufacturer	Part Number
1	R3	RES 221 OHM 1/10W 1% 0603 SMD	Panasonic - ECG	ERJ-3EKF2210V
1	R4	RES 10.0 OHM 1/10W 1% 0603 SMD	Panasonic - ECG	ERJ-3EKF10R0V
4	R5, R7, R10, R12	RES 10.0K OHM 1/10W 1% 0603 SMD	Panasonic - ECG	ERJ-3EKF1002V
2	R6, R8	RES 475 OHM 1/10W 1% 0603 SMD	Panasonic - ECG	ERJ-3EKF4750V
1	R9	RES 10.0M OHM 1/10W 1% 0603 SMD	Yageo® Corporation	RC0603FR-0710ML
1	R11	RES ZERO OHM 1/10W 5% 0603 SMD	Panasonic - ECG	ERJ-3GEY0R00V
1	R13	RES 1.00M OHM 1/10W 1% 0603 SMD	Yageo Corporation	RC0603FR-071ML
3	R20, R21, R24	DO NOT POPULATE	—	—
2	R25, R26	RES 4.75K OHM 1/10W 1% 0603 SMD	Panasonic - ECG	ERJ-3EKF4751V
3	SW0, SW1, SW2	LIGHT TOUCH SWITCH SMD 260GF 5MM - DO NOT POPULATE	—	—
2	SW3, SW4	LIGHT TOUCH SWITCH SMD 260GF 5MM	Panasonic - ECG	EVQ-PLMA15
1	U1	Three-Channel Analog Front-End Device	Microchip Technology Inc.	MCP2030-I/ST
1	U2	RESONATOR SAW 433.92MHZ 1 PORT	ECS Inc	ECS-SDR1-4339-TR
1	U3	PIC16F636-TSSOP	Microchip Technology Inc.	PIC16F636-ST
1	U4	18-Bit Analog-to-Digital Converter with I2C Interface and On-Board Reference	Microchip Technology Inc.	PIC18F4680-I/P
1	U5	DO NOT POPULATE	—	—
1	U6	SOCKET,IC,14PIN,MACHINE TOOLED LOW PROFILE,SOLDERTAIL	JAMECO VALUEPRO	6100-14-R

Note 1: The components listed in this Bill of Materials are representative of the PCB assembly. The released BOM used in manufacturing uses all RoHS-compliant components

TABLE B-2: BASE STATION DEMO BOARD - BILL OF MATERIALS

Qty	Reference Designator	Description	Manufacturer	Part Number
1	ANTENNA LEAD	WIRE 24AWG STRAND BLACK 6.8 INCHES LONG	Alpha Wire Company	3050 BK005
5	C1, C7, C10, C16, C24	CAP .1UF 50V CERM CHIP 1206 X7R	Panasonic® - ECG	ECJ-3VB1H104K
1	C2	CAP .01UF 400V POLYPROPYLENE	Panasonic - ECG	ECQ-P4103JU
1	C5	CAP 2200PF 500V CERAMIC DISC Y5P	Panasonic - ECG	D222K33Y5PL63L0R
1	C6	CAP CER 1UF 10V X5R RAD	TDK® Corporation	FK28X5R1A105K
1	C8	CAP CERAMIC 100PF 50V NP0 1206	Yageo Corporation®	CC1206JRNPO9BN101
1	C9	CAP CERAMIC 10000PF 50V NP0 1206	Panasonic - ECG	ECJ-3FC1H103J
1	C11	CAP CERAMIC 470PF 50V NP0 1206	Kemet® Electronics Corp	C1206C471J5GACTU
1	C12	CAP 270PF 50V CERAMIC X7R 1206	Yageo Corporation	CC1206KRX7R9BB271
1	C13	CAP 100UF 50V ELECT FC RADIAL	Panasonic - ECG	EEU-FC1H101
1	C14	CAP 47UF 10V ELECT FC RADIAL	Panasonic - ECG	EEU-FC1A470
1	C15	CAP 10UF 10V TANTALUM TE SMD	Kemet® Electronics Corp	T491A106K010AT

Note 1: The components listed in this Bill of Materials are representative of the PCB assembly. The released BOM used in manufacturing uses all RoHS-compliant components.

MCP2030 Bidirectional Communication Demo Kit User's Guide

TABLE B-2: BASE STATION DEMO BOARD - BILL OF MATERIALS (CONTINUED)

Qty	Reference Designator	Description	Manufacturer	Part Number
2	C17, C18,	CAP 1UF 16V CERAMIC 0805 X5R	Panasonic - ECG	ECJ-2FB1C105K
2	C22, C23	CAP CERAMIC 20PF 50V NPO 1206	Yageo Corporation	CC1206JRNPO9BN200
1	D1	DIODE ULTRA FST SW 600V 1A DO-41	Diodes Inc	UF1005-T
2	D2, D3	LED 2X3MM 565NM GRN WTR CLR SMD	Lumex Opto/Components Inc	SML-LX23GC-TR
4	D4, D9, D10, D11	1N5819 RECT SCHOTTKY 1A 40V DO-214AA	Micro Commercial Co.	SK14-TP
2	D5, D8	DIODE SCHOTTKY 100V 1.5A D-64	International Rectifier	10MQ100NPBF
1	D6	DIODE ZENER 27V 1W 5% DO-41	Diodes Inc	1N4750A-T
2	D7, D13	DIODE SWITCH 75V 500MW MIN-IMELF	Diodes Inc	LL4148-13
1	J1	CONN HEADER 6PS R/A DL .163 GOLD	Tyco [®] Electronics/Amp	1-770969-1
1	J2	CONN D-SUB PLUG R/A 9POS PCB AU	Tyco Electronics/Amp	5747250-4
1	J3	CONN MOD JACK 6-6 R/A PCB 50AU	Tyco Electronics/Amp	5520470-3
1	J4	CONN POWER JACK 2.5MM PCB CIRC	CUI Inc	PJ-102B
1	L1	IND 160UH 500V AIR	MC Davis	Microchip-160mH
1	LCD1	LCD MODULE 16X2 CHARACTER	Lumex [®] Opto/Components Inc	LCM-S01602DTR/M
1	LCD Connector	CONN SOCKET 16 PIN STRIP	SAMTEC	SSW-116-02-G-S
1	LCD HEADER	CONN HEADER 17POS .100 VERT TIN	ValuePro	7000-1X17SG
1	R1	RES 392K OHM 1/4W 1% 1206 SMD	Panasonic - ECG	ERJ-8ENF3923V
1	R2	RES 11.0K OHM 1/4W 1% 1206 SMD	Panasonic - ECG	ERJ-8ENF1102V
1	R3	RES 10 OHM 1/4W 1% 1206 SMD	Panasonic - ECG	ERJ-8ENF10R0V
1	R4	RES 49.9 OHM 1/4W 1% 1206 SMD	Panasonic - ECG	ERJ-8ENF49R9V
1	R5	RES 162K OHM 1/4W 1% 1206 SMD	Yageo Corporation	9C12063A1623FKHFT
1	R6	RES 3.92K OHM 1/4W 1% 1206 SMD	Panasonic - ECG	ERJ-8ENF3921V
1	R7	RES 16.5K OHM 1/4W 1% 1206 SMD	Yageo Corporation	9C12063A1652FKHFT
1	R8	RES 64.9 OHM 1/4W 1% 1206 SMD	Panasonic - ECG	ERJ-8ENF64R9V
1	R9	RES 4.87K OHM 1/4W 1% 1206 SMD	Yageo Corporation	9C12063A4871FKHFT
1	R10	RES 5.11K OHM 1/4W 1% 1206 SMD	Panasonic - ECG	ERJ-8ENF5111V
1	R12	RES 1.00K OHM 1/4W 1% 1206 SMD	Panasonic - ECG	ERJ-8ENF1001V
1	R13	RES 4.75K OHM 1/8W 1% 0805 SMD	Yageo Corporation	9C08052A4751FKHFT
1	R14	RES 1.00K OHM 1/8W 1% 0805 SMD	Panasonic - ECG	ERJ-6ENF1001V
1	R15	RES 121 OHM 1/8W 1% 0805 SMD	Panasonic - ECG	ERJ-6ENF1210V
1	R16	RES 274 OHM 1/4W 1% 1206 SMD	Panasonic - ECG	ERJ-8ENF2740V
2	R18, R19	RES 15.0K OHM 1/8W 1% 0805 SMD	Panasonic - ECG	ERJ-6ENF1502V
1	R20	RES 24.9K OHM 1/8W 1% 0805 SMD	Panasonic - ECG	ERJ-6ENF2492V
1	R26	RES 30K OHM 1/8W 5% 0805 SMD	Panasonic - ECG	ERJ-6GEYJ303V
1	R27	RES 10.0K OHM 1/4W 1% 1206 SMD	Panasonic - ECG	ERJ-8ENF1002V

Note 1: The components listed in this Bill of Materials are representative of the PCB assembly. The released BOM used in manufacturing uses all RoHS-compliant components.

MCP2030 Bidirectional Communication Demo Kit User's Guide

TABLE B-2: BASE STATION DEMO BOARD - BILL OF MATERIALS (CONTINUED)

Qty	Reference Designator	Description	Manufacturer	Part Number
2	R28,R29	RES 4.75K OHM 1/4W 1% 1206 SMD	Panasonic - ECG	ERJ-8ENF4751V
2	S1, S2	SWITCH LT TOUCH 6X3.5 100GF SMD	Panasonic - ECG	EVQ-PJS04K
7	TP1 - TP7	TEST POINT PC MULTI PURPOSE WHT	Keystone Electronics®	5012
2	TP8 & TP9	TEST POINT PC MULTI PURPOSE BLK	Keystone Electronics	5011
1	U1	9A High Speed MOSFET Driver	Microchip Technology Inc.	TC4422CAT
1	U2	Rail-to-Rail Input/Output, 10 MHz Op Amp	Microchip Technology Inc.	MCP6022-I/SN
1	U3	28/40-Pin High-Performance, Enhanced Flash	Microchip Technology Inc.	PIC18F4680-I/P
1	U3 Socket	IC Socket 40 PIN .600 GOLD	Mill-Max Manufacturing Corp.	110-43-640-41-001000
1	U4	Receiver AM Hybrid 433 MHz Module	http://www.okwelectronics.com/index.html	AMHRR3-433
1	U5	LIN Transceiver with Voltage Regulator	Microchip Technology Inc.	MCP201-I/SN
1	U6	Microcontroller with CAN High-Speed CAN Transceiver	Microchip Technology Inc	MCP2551-I/SN
1	VR1	IC 5.0 100MA LDO VREG SOT23	National Semiconductor®	LM3480IM3-5.0
1	Y1	CRYSTAL 20.000MHZ 20PF HC-49/US	ECS Inc	ECS-200-20-4X

Note 1: The components listed in this Bill of Materials are representative of the PCB assembly. The released BOM used in manufacturing uses all RoHS-compliant components.

NOTES:



MICROCHIP

WORLDWIDE SALES AND SERVICE

AMERICAS

Corporate Office

2355 West Chandler Blvd.
Chandler, AZ 85224-6199
Tel: 480-792-7200
Fax: 480-792-7277
Technical Support:
<http://support.microchip.com>
Web Address:
www.microchip.com

Atlanta

Duluth, GA
Tel: 678-957-9614
Fax: 678-957-1455

Boston

Westborough, MA
Tel: 774-760-0087
Fax: 774-760-0088

Chicago

Itasca, IL
Tel: 630-285-0071
Fax: 630-285-0075

Dallas

Addison, TX
Tel: 972-818-7423
Fax: 972-818-2924

Detroit

Farmington Hills, MI
Tel: 248-538-2250
Fax: 248-538-2260

Kokomo

Kokomo, IN
Tel: 765-864-8360
Fax: 765-864-8387

Los Angeles

Mission Viejo, CA
Tel: 949-462-9523
Fax: 949-462-9608

Santa Clara

Santa Clara, CA
Tel: 408-961-6444
Fax: 408-961-6445

Toronto

Mississauga, Ontario,
Canada
Tel: 905-673-0699
Fax: 905-673-6509

ASIA/PACIFIC

Asia Pacific Office

Suites 3707-14, 37th Floor
Tower 6, The Gateway
Harbour City, Kowloon
Hong Kong
Tel: 852-2401-1200
Fax: 852-2401-3431

Australia - Sydney

Tel: 61-2-9868-6733
Fax: 61-2-9868-6755

China - Beijing

Tel: 86-10-8528-2100
Fax: 86-10-8528-2104

China - Chengdu

Tel: 86-28-8665-5511
Fax: 86-28-8665-7889

China - Fuzhou

Tel: 86-591-8750-3506
Fax: 86-591-8750-3521

China - Hong Kong SAR

Tel: 852-2401-1200
Fax: 852-2401-3431

China - Qingdao

Tel: 86-532-8502-7355
Fax: 86-532-8502-7205

China - Shanghai

Tel: 86-21-5407-5533
Fax: 86-21-5407-5066

China - Shenyang

Tel: 86-24-2334-2829
Fax: 86-24-2334-2393

China - Shenzhen

Tel: 86-755-8203-2660
Fax: 86-755-8203-1760

China - Shunde

Tel: 86-757-2839-5507
Fax: 86-757-2839-5571

China - Wuhan

Tel: 86-27-5980-5300
Fax: 86-27-5980-5118

China - Xian

Tel: 86-29-8833-7250
Fax: 86-29-8833-7256

ASIA/PACIFIC

India - Bangalore

Tel: 91-80-4182-8400
Fax: 91-80-4182-8422

India - New Delhi

Tel: 91-11-4160-8631
Fax: 91-11-4160-8632

India - Pune

Tel: 91-20-2566-1512
Fax: 91-20-2566-1513

Japan - Yokohama

Tel: 81-45-471-6166
Fax: 81-45-471-6122

Korea - Gumi

Tel: 82-54-473-4301
Fax: 82-54-473-4302

Korea - Seoul

Tel: 82-2-554-7200
Fax: 82-2-558-5932 or
82-2-558-5934

Malaysia - Penang

Tel: 60-4-646-8870
Fax: 60-4-646-5086

Philippines - Manila

Tel: 63-2-634-9065
Fax: 63-2-634-9069

Singapore

Tel: 65-6334-8870
Fax: 65-6334-8850

Taiwan - Hsin Chu

Tel: 886-3-572-9526
Fax: 886-3-572-6459

Taiwan - Kaohsiung

Tel: 886-7-536-4818
Fax: 886-7-536-4803

Taiwan - Taipei

Tel: 886-2-2500-6610
Fax: 886-2-2508-0102

Thailand - Bangkok

Tel: 66-2-694-1351
Fax: 66-2-694-1350

EUROPE

Austria - Wels

Tel: 43-7242-2244-39
Fax: 43-7242-2244-393

Denmark - Copenhagen

Tel: 45-4450-2828
Fax: 45-4485-2829

France - Paris

Tel: 33-1-69-53-63-20
Fax: 33-1-69-30-90-79

Germany - Munich

Tel: 49-89-627-144-0
Fax: 49-89-627-144-44

Italy - Milan

Tel: 39-0331-742611
Fax: 39-0331-466781

Netherlands - Drunen

Tel: 31-416-690399
Fax: 31-416-690340

Spain - Madrid

Tel: 34-91-708-08-90
Fax: 34-91-708-08-91

UK - Wokingham

Tel: 44-118-921-5869
Fax: 44-118-921-5820

12/08/06