

Fast and easy migration from USB micro-B to Type-C



Features

- USB Type-C SINK port
- Short-to VBUS protection up to 28 V
- Low bill of material cost, small footprint
- Source power budget reporting LEDs

Description

The **EVAL-SCS002V1** shows minimum USB-C sink implementation. It can be used as a small footprint reference design for fast migration of any USB mini-B, micro-B or STD-B application to USB-C.

It is based on the STUSB4500L USB controller IC and is certified as “Power Sinking Device” (TID #1455).

Product status link

[EVAL-SCS002V1](#)

Related product

Stand-alone USB-C sink controller	STUSB4500L
-----------------------------------	------------

1 Application schematic

Figure 1. Application schematic

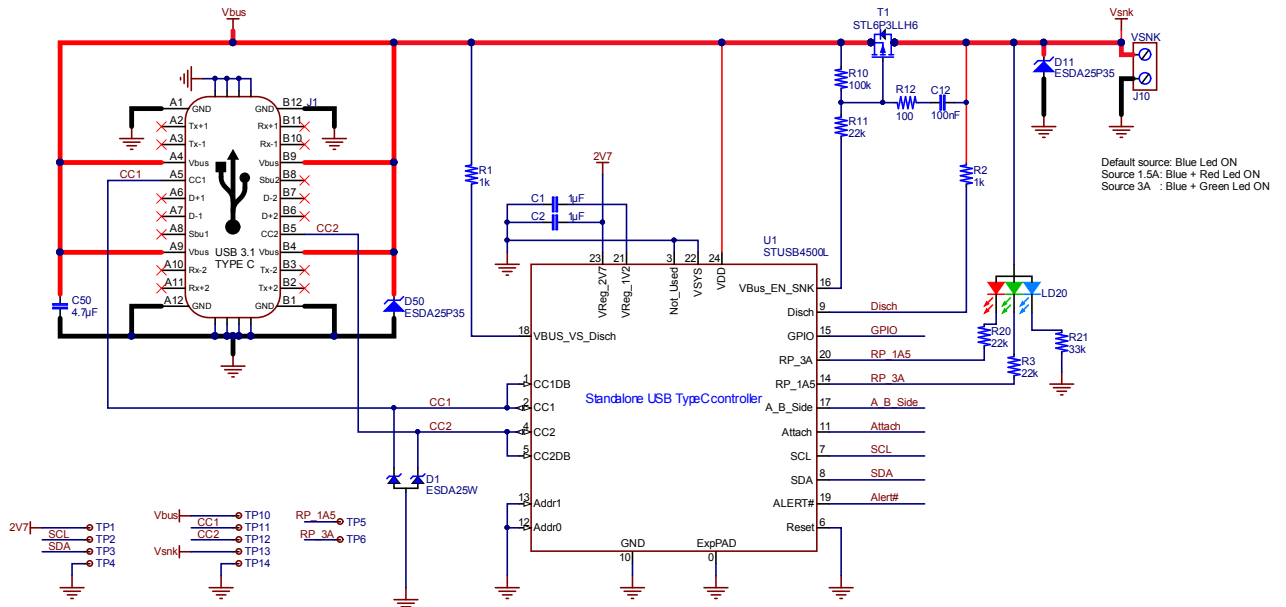

Revision history

Table 1. Document revision history

Date	Version	Changes
04-Oct-2019	1	Initial release.
20-Dec-2019	2	Updated the cover page.
10-May-2021	3	Updated cover image.

IMPORTANT NOTICE – PLEASE READ CAREFULLY

STMicroelectronics NV and its subsidiaries (“ST”) reserve the right to make changes, corrections, enhancements, modifications, and improvements to ST products and/or to this document at any time without notice. Purchasers should obtain the latest relevant information on ST products before placing orders. ST products are sold pursuant to ST’s terms and conditions of sale in place at the time of order acknowledgement.

Purchasers are solely responsible for the choice, selection, and use of ST products and ST assumes no liability for application assistance or the design of Purchasers’ products.

No license, express or implied, to any intellectual property right is granted by ST herein.

Resale of ST products with provisions different from the information set forth herein shall void any warranty granted by ST for such product.

ST and the ST logo are trademarks of ST. For additional information about ST trademarks, please refer to www.st.com/trademarks. All other product or service names are the property of their respective owners.

Information in this document supersedes and replaces information previously supplied in any prior versions of this document.

© 2021 STMicroelectronics – All rights reserved