

REVISIONS					
REV	ECO	DESCRIPTION	DATE	BY	APPR
B1	-	RELEASED DRAWING	JULY-1-2014	BEN	TOMMY

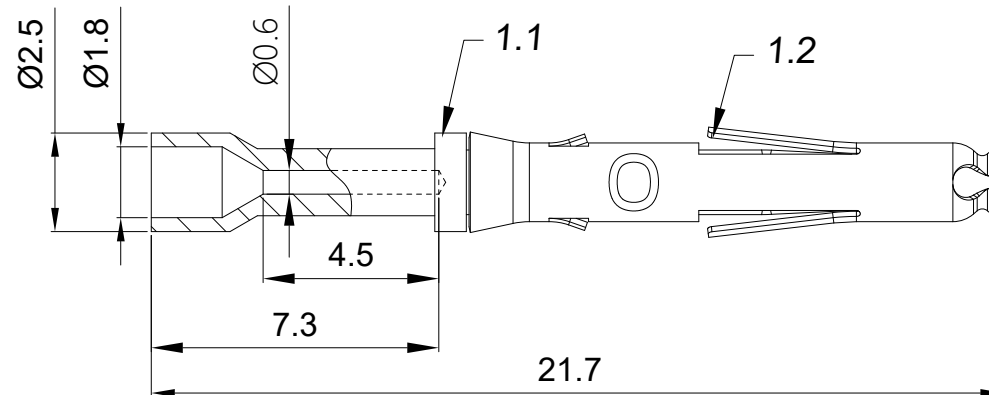

NOTES: (UNLESS OTHERWISE SPECIFIED)

1. MATERIAL:

- 1.1. CONTACT BODY: COPPER ALLOY.
- 1.2. POSITIONING CLIP: STAINLESS STEEL.

2. SPECIFICATIONS:

- 2.1 CURRENT RATING: 7.5A(MAX).
- 2.2 TERMINATION TYPE: CRIMPING.
- 2.3 CRIMP WIRE RANGE: 30~28AWG.

3. SUITABLE SOCKET TYPE: MP28W23xx .

4. ALL DIMENSION ARE FOR REFERENCE USE ONLY.

5. ROHS COMPLIANT.

P/N	CONTACT PLATING(MATING AREA)
MS28W23F	GOLD FLASH PLATING OVER NICKEL.
MS28W23G10	10μ" GOLD PLATING OVER NICKEL.
MS28W23G15	15μ" GOLD PLATING OVER NICKEL.
MS28W23G30	30μ" GOLD PLATING OVER NICKEL.

QUANTITY	PART NUMBER	DESCRIPTION	ITEM
MATERIALS LIST			
<small>UNLESS OTHERWISE SPECIFIED: 1) All dimensions are in metric(mm). 2) Tolerances are as follows: 1 PL DEC ±0.30 2 PL DEC ±0.15 3 PL DEC ±0.08 Fractions ±1/64 Angles ±1° 3) Note reference = </small>		SIGNATURES DRAWN: BEN CHECKED: ENGINEER: APPROVAL: CUSTOMER:	DATE JULY-1-2014
<small>MATERIAL SPECIFICATIONS: PROCESS SPECIFICATIONS: NEXT ASSY:</small>		<div style="text-align: center;"> Sine Systems - www.amphenol-sine.com 44724 Morley Drive Clinton Township, MI 48036 ECO-MATE, SOCKET CONTACT MACHINE, 30-28AWG, SIZE 20 </div>	
<small>THIS DRAWING IS SUPPLIED FOR INFORMATION ONLY. DESIGN FEATURES, SPECIFICATIONS AND PERFORMANCE DATA SHOWN HEREON ARE THE PROPERTY OF THE AMPHENOL CORPORATION. NO RIGHTS OF REPRODUCTION ARE IMPLIED. ALL DIMENSIONS ARE SUBJECT TO NORMAL MANUFACTURING VARIATIONS.</small>		SIZE: B TYPE: C- SCALE: NONE	DWG NO.: MS28W23xx REVISION: B1 SHEET 1 OF 1

TITLE: ECO-MATE SOCKET CONTACT MACHINE, 30-28AWG, SIZE 20
 DWG NO: MS28W23xx
 REV: B1
 SH: 1
 OF: 1