

STRAIGHT PLUG FULL CRIMP TYPE

R143.082.027

CABLE 5/50S

Series : TNC

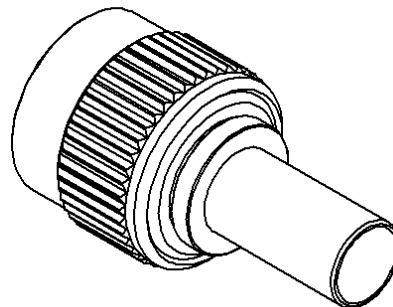
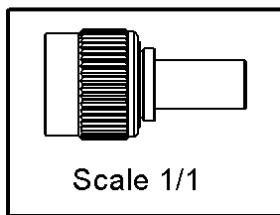
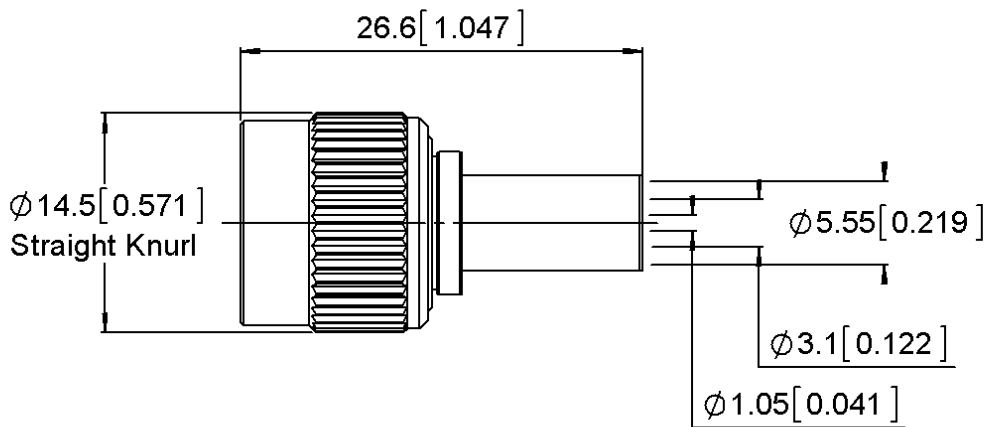

All dimensions are in mm.

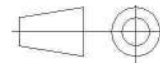

COMPONENTS	MATERIALS	PLATING (µm)
BODY	BRASS.	BBR 2
CENTER CONTACT	BERYLLIUM COPPER	GOLD 0.5 OVER COPPER 2.5
OUTER CONTACT	-	-
INSULATOR	PTFE	-
GASKET	SILICONE RUBBER	-
OTHERS PARTS	BRASS.	BBR 2
-	-	-
-	-	-

Issue : 1307 A

In the effort to improve our products, we reserve the right to make changes judged to be necessary.



STRAIGHT PLUG FULL CRIMP TYPE

R143.082.027

CABLE 5/50S

Series : TNC

PACKAGING

Standard	Unit	Other
100	'W' option	Contact us

SPECIFICATION

ELECTRICAL CHARACTERISTICS

Impedance	50	Ω
Frequency	0-11	GHz
VSWR	TBD + 0,0000	x F(GHz) Maxi
Insertion loss	TBD	\sqrt{F} (GHz) dB Maxi
RF leakage	- (**)	- F(GHz)) dB Maxi
Voltage rating	500	Veff Maxi
Dielectric withstanding voltage	1500	Veff mini
Insulation resistance	5000	M Ω mini

CABLE ASSEMBLY

Stripping	a	b	c	d	e	f
mm	5,20	8,50	15,8	0,00	10,6	0,00

Assembly instruction : **Crimp 03***

Recommended cable(s)
LMR 195
AEP-195FR

Characteristics indicated on this data sheet are those that can be achieved with the highest performance cable. Intrinsic limitations of the cable may diminish the performance of the assembly

Cable retention

- pull off **90** N mini
- torque **NA** N.cm

MECHANICAL CHARACTERISTICS

Center contact retention		
Axial force – Mating end	27	N mini
Axial force – Opposite end	27	N mini
Torque	NA	N.cm mini

TOOLING

Part Number	Description	Hexagon
.	.	.
R282.235.011	CRIMPING DIES M22520/5-11	1.73- 5.41
R282.293.000	CRIMPING TOOL M22520/5-01	-
R282.223.000	CRIMPING TOOL	1.73- 5.41

Recommended torque		
Mating	46	N.cm
Panel nut	NA	N.cm
Clamp nut	NA	N.cm
A/F clamp nut	0,0000	mm

Mating life	500	Cycles mini
Weight	6,8500	g

OTHER CHARACTERISTICS

** RF Leakage = -60 dB min. at 2-3 GHz
*prior to step two of Crimp 03, slide disk insulator onto center conductor, And bottom contact on disk insulator

ENVIRONMENTAL

Operating temperature	-65/+165	$^{\circ}$ C
Hermetic seal	NA	Atm.cm3/s
Panel leakage	NA	

Issue : 1307 A

In the effort to improve our products, we reserve the right to make changes judged to be necessary.

