

REVISIONS					
REV	ECO	DESCRIPTION	DATE	BY	APPR
B1	-	RELEASED DRAWING	JUN-23-2014	BEN	TOMMY

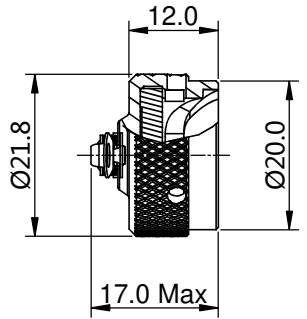
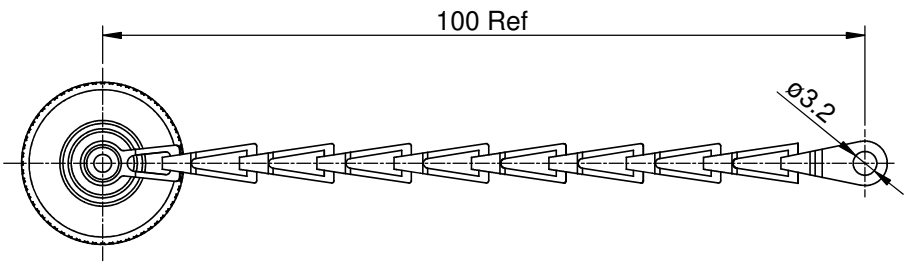

RT010DC X X
① ②

P/N	①	②	CHAIN	PLATING
RT010DC	---	---	NO CHAIN	NICKEL PLTING
RT010DCA	---	A	NO CHAIN	BLACK ANODIZING
RT010DCG	G	---	CHAIN	NICKEL PLTING
RT010DCGA	G	A	CHAIN	BLACK ANODIZING

- NOTES : (UNLESS OTHERWISE SPECIFIED)**
- MATERIAL :**
 RIVET : COPPER ALLOY,NICKEL PLATING
 CHAIN : STAINLESS STEEL.
 DUST CAP : AL ALLOY , NICKEL PLATED.
 O-RING : NBR.
 - SPECIFICATIONS :**
 2.1 OPERATING TEMPERATURE : -40°C ~ +105°C.
 2.2 IP--CLASS : IP67.
 2.3 MATING CYCLES DURABILITY : 500 CYCLES MIN.
 2.4 ROHS COMPLIANT.
 - ALL DIMENSIONS ARE FOR REFERENCE USE ONLY.

SEE PART NUMBER CHART		DESCRIPTION		ITEM
QUANTITY	PART NUMBER			
MATERIALS LIST				
<small>UNLESS OTHERWISE SPECIFIED</small> 1) All dimensions are in metric(mm). 2) Tolerances are as follows: 1 PL DEC ±0.30 Fractions: ±1/64 2 PL DEC ±0.15 Angles ±1° 3 PL DEC ±0.08 3) Note reference =		SIGNATURES DRAWN: BEN CHECKED: ENGINEER: APPROVAL:		DATE JUN-23-2014
<small>MATERIAL SPECIFICATIONS:</small> CUSTOMER:		 Sine Systems - www.amphenol-sine.com 44724 Morley Drive Clinton Township, MI 48036		
<small>PROCESS SPECIFICATIONS:</small> NEXT ASSY:		<small>THIS DRAWING IS SUPPLIED FOR INFORMATION ONLY. DESIGN FEATURES, SPECIFICATIONS AND PERFORMANCE DATA SHOWN HEREON ARE THE PROPERTY OF THE AMPHENOL CORPORATION. NO RIGHTS OF REPRODUCTION ARE IMPLIED. ALL DIMENSIONS ARE SUBJECT TO NORMAL MANUFACTURING VARIATIONS.</small>		<small>REVISION</small> B1
		<small>SIZE</small> B	<small>TYPE</small> C-	<small>DWG NO.</small> RT010DCxx
		<small>SCALE</small> NONE	<small>SHEET</small> 1 <small>OF</small> 1	

TITLE: ECO-MATE,DUST CAP FOR RECEPTACLES SIZE 10
 DWG NO.: RT010DCxx
 REV: B1
 SH: 1
 OF: 1