

ITEM	QTY	PART NUMBER	PART DESCRIPTION
1	1	C-174	T-1¼ (5mm) LED CLIP
2	1	R-174	T-1¼ (5mm) LED RING

REV.	DESCRIPTION	DATE	APPROVED
B	Engineering Update w/o Changes	02/26/04	M. C.
C	Remove Material Code	05/28/16	J. C.

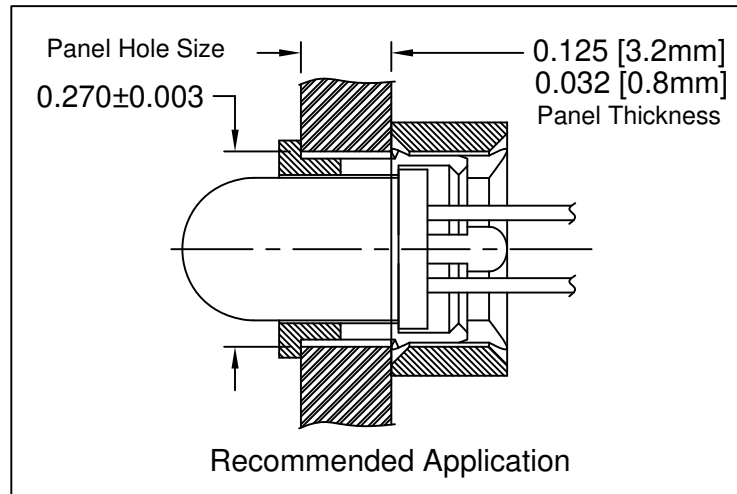
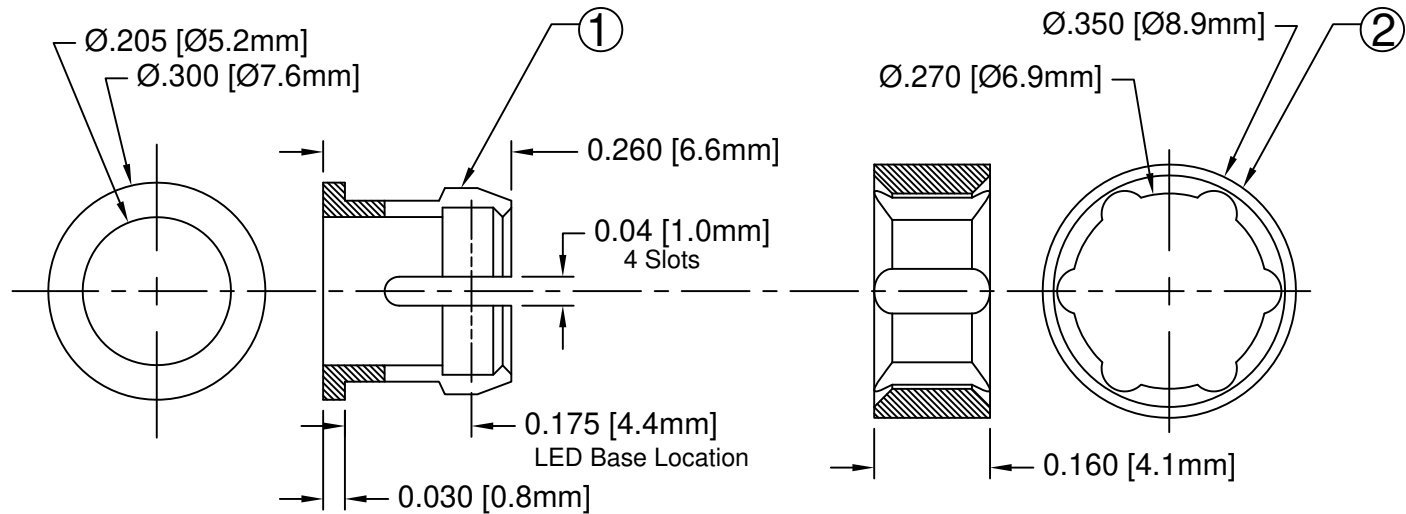

STANDARD TOLERANCE (UNLESS OTHERWISE SPECIFIED)	
DECIMALS	ANGULAR
.X ±.1	X° ± 1°
.XX ±.01	
.XXX ±.005	

BIVAR®

4 THOMAS, IRVINE, CA. 92618
TEL: (949) 951-8808 FAX: (949) 951-3974



TITLE:
T-1¼ LED CLIP AND RING SET

DESIGNED:
S. Irving

DATE:
11/24/98

PART NO: CR-174
REVISION: C

CHECKED:
M. Chen

DATE:
05/17/02

CAGE CODE : 32559 **SHEET #** 1 **OF** 1
CAD GENERATED DOCUMENT. DO NOT MEASURE DRAWING.

2. MATERIAL: NYLON 6/6, 94V-2, BLACK.

1. GENERAL SPECIFICATIONS: BIVAR MOLDED COMPONENT SPECIFICATION BV00-E101.