

250 W mainstream compressor solution based on STSPIN32F0601Q and STGD5H60DF



Features

- Complete system solution made by ready-to-use hardware and firmware
- Fitting wide range of applications supplied from the mains, rated up to 250 W:
 - refrigerator compressors
 - pumps and fans
 - industrial appliances
- High efficiency value:
 - Inverter efficiency > 96.5% at 3000 rpm
- Very low stand-by power consumption and overcurrent/undervoltage protections
- Based on [STSPIN32F0601Q](#) intelligent 3-phase motor controller with embedded STM32
- Power supply based on [VIPER122](#) in buck configuration to generate on-board DC voltages
- Inverter power stage based on [STGD5H60DF](#) IGBT rated 600 V and 5 A
- Compact size: 7.5 x 11.2 cm
- Equipped with proven sensorless field-oriented control (FOC) firmware in one-shunt or 2+1 shunt topology
- RoHS compliant

Description

The [STEVAL-CTM011V1](#) is a three-phase inverter based on the [STSPIN32F0601Q](#) controller, which embeds a 3-phase 600 V gate driver and an Arm® Cortex®-M0 STM32 MCU. The power stage features [STGD5H60DF](#) IGBTs.

The board supports one-shunt and two- plus one-shunt sensing topology. You can properly set the shunt topology by populating the related shunt resistors (RS1, RS2, and RS3).

Moreover, you can implement a sensorless field-oriented control (FOC). This allows driving permanent magnet synchronous motors (PMSMs) and brushless DC (BLDC) motors to cover a wide range of applications, such as refrigerator compressors, pumps, fans, and industrial appliances.

The [STEVAL-CTM011V1](#) evaluation board is compatible with a wide range of input voltages. It includes a power supply stage with the [VIPER122](#) in buck configuration that generates +15 V and +3.3 V supply voltages required by the application.

The companion firmware is [X-CUBE-MCSDK](#), available for download on www.st.com, to be used with the [STSW-CTM011](#) firmware example for compressor motors.

You can compile, debug, and configure the firmware through the [STM32CubeIDE](#) and [B-STLINK-ISOL](#) plus [STLINK-V3SET](#).

SWD and UART TX-RX connectors are also available.

Product summary

250 W mainstream compressor solution based on STSPIN32F0601Q and STGD5H60DF	STEVAL-CTM011V1
Firmware example for compressor motors	STSW-CTM011
STM32 motor control software development kit	X-CUBE-MCSDK
600 V three-phase controller with MCU	STSPIN32F0601Q
H-series, 600 V, 5 A high-speed trench gate field-stop IGBT	STGD5H60DF
Applications	Motor Control

1 Schematic diagrams

Figure 1. STEVAL-CTM011V1 circuit schematic (1 of 2)

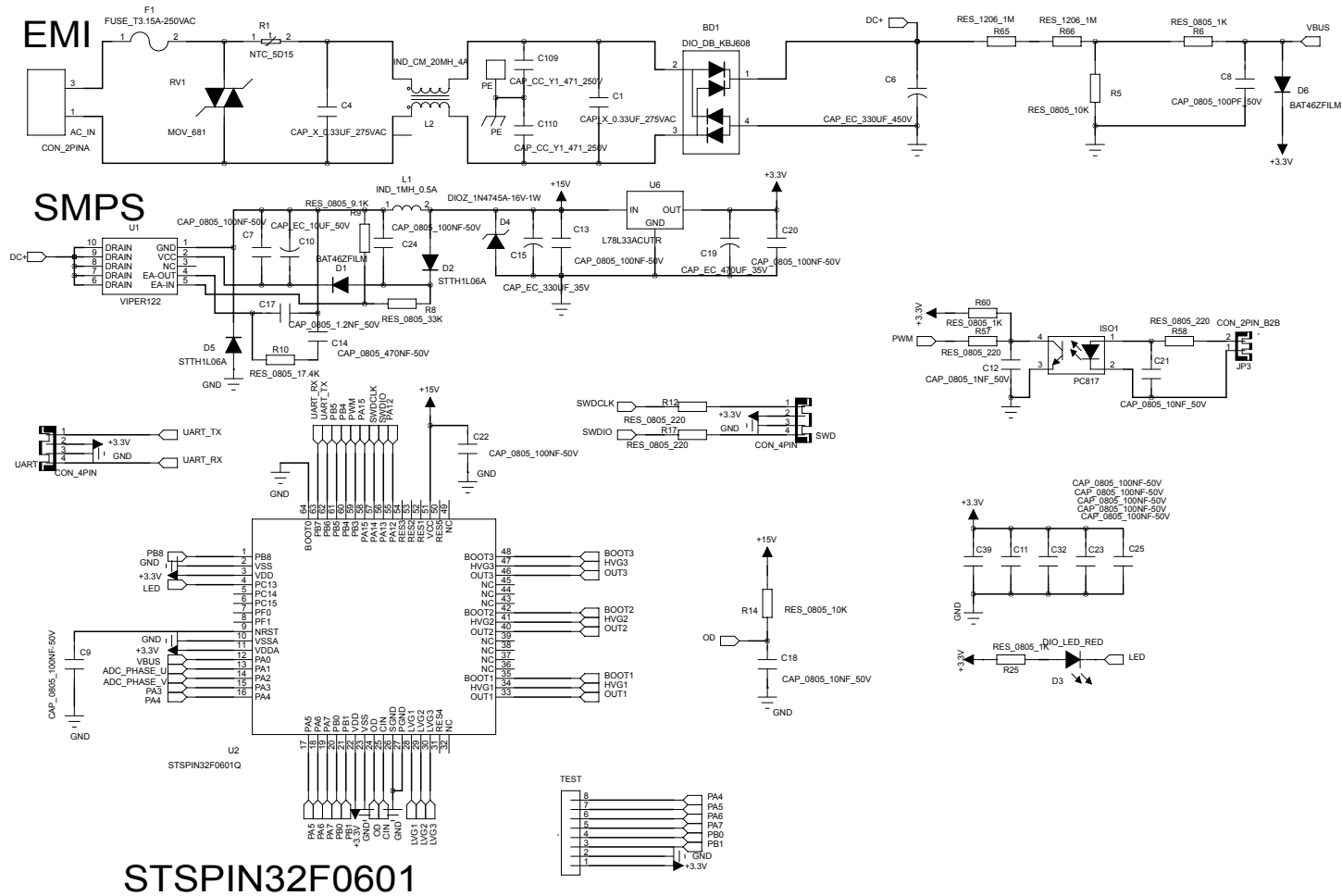
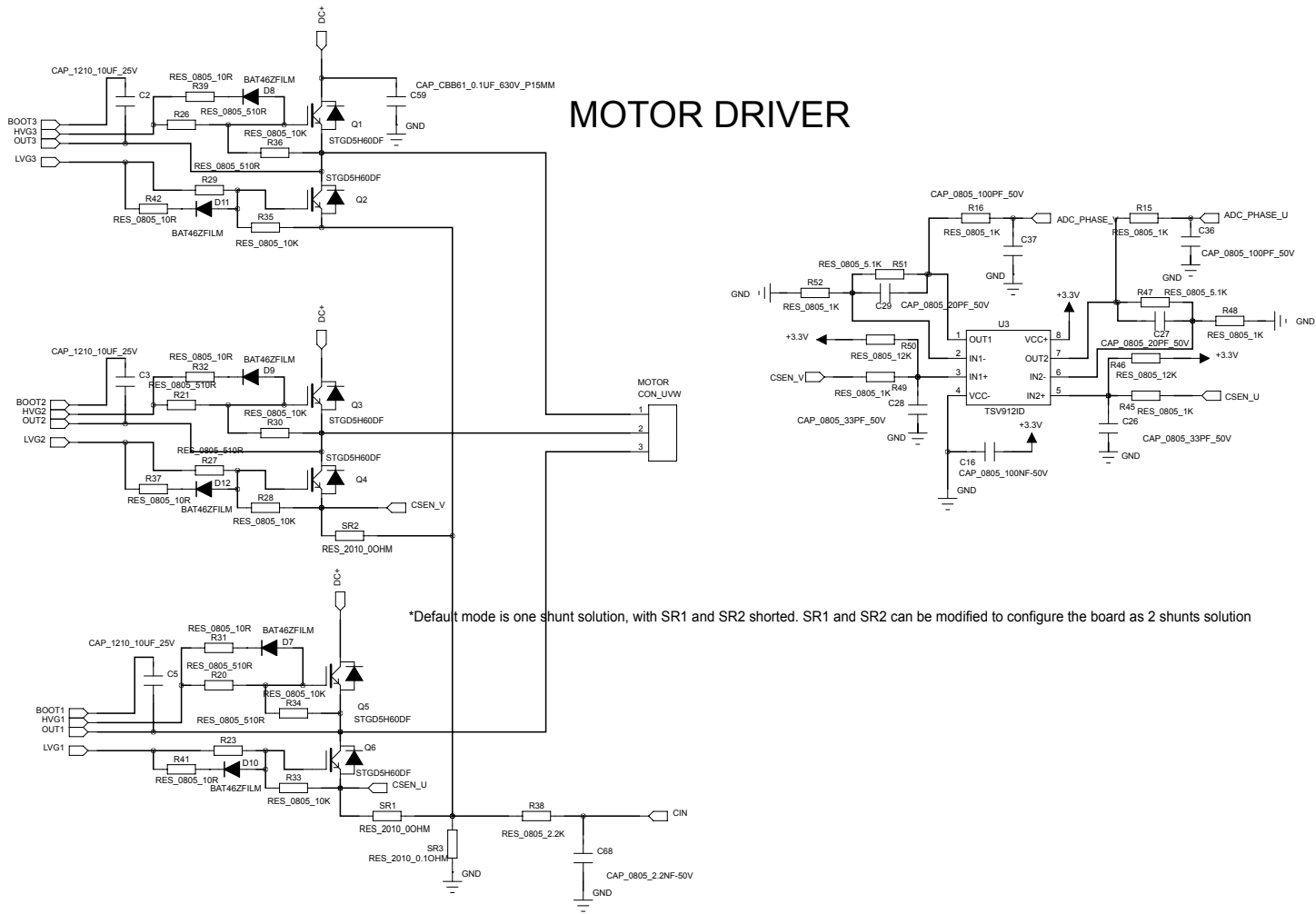

Figure 2. STEVAL-CTM011V1 circuit schematic (2 of 2)



2 Board versions

Table 1. STEVAL-CTM011V1 versions

Finished good	Schematic diagrams	Bill of materials
STEVAL\$CTM011V1A ⁽¹⁾	STEVAL\$CTM011V1A schematic diagrams	STEVAL\$CTM011V1A bill of materials

1. This code identifies the STEVAL-CTM011V1 evaluation board first version.

Revision history

Table 2. Document revision history

Date	Revision	Changes
18-Jan-2021	1	Initial release.
10-Mar-2022	2	Updated cover page features.
04-May-2022	3	Updated cover page features and description.
05-Jul-2022	4	Updated cover page features.

IMPORTANT NOTICE – READ CAREFULLY

STMicroelectronics NV and its subsidiaries (“ST”) reserve the right to make changes, corrections, enhancements, modifications, and improvements to ST products and/or to this document at any time without notice. Purchasers should obtain the latest relevant information on ST products before placing orders. ST products are sold pursuant to ST’s terms and conditions of sale in place at the time of order acknowledgment.

Purchasers are solely responsible for the choice, selection, and use of ST products and ST assumes no liability for application assistance or the design of purchasers’ products.

No license, express or implied, to any intellectual property right is granted by ST herein.

Resale of ST products with provisions different from the information set forth herein shall void any warranty granted by ST for such product.

ST and the ST logo are trademarks of ST. For additional information about ST trademarks, refer to www.st.com/trademarks. All other product or service names are the property of their respective owners.

Information in this document supersedes and replaces information previously supplied in any prior versions of this document.

© 2022 STMicroelectronics – All rights reserved