



THERMO click™

1. Introduction



THERMO Click™ is an accessory board in **mikroBUS™** form factor. It's a compact solution for adding thermocouple to your device. It features **MAX31855K** thermocouple-to-digital converter as well as **PCC-SMP** connector for K-type thermocouple probes. THERMO Click™ communicates with the target board via SPI interface (Read-only). The board is designed to use 3.3V power supply only. It has a LED diode (GREEN) that indicates the presence of power supply.

2. Soldering the headers

Before using your click board™, make sure to solder 1x8 male headers to both left and right side of the board. Two 1x8 male headers are included with the board in the package.



1

2

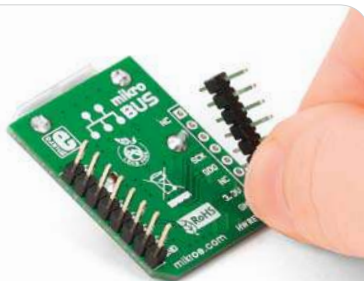

Turn the board upside down so that bottom side is facing you upwards. Place shorter parts of the header pins in both soldering pad locations.

3



Turn the board upward again. Make sure to align the headers so that they are perpendicular to the board, then solder the pins carefully.

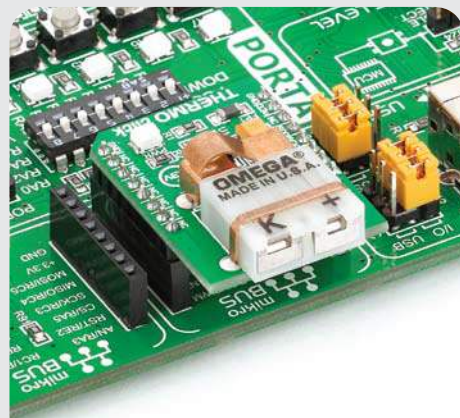

4. Essential features

The combination of the **MAX31855K** and **PCC-SMP** connector results in support for high accuracy temperature measurement. The **MAX31855K** has a temperature range between -270 and 1372°C with sensitivity of about 41µV/°C. It has a built-in 14-bit ADC converter. All these features make this board ideal for thermostatic, process-control, monitoring applications and more.

3. Plugging the board in

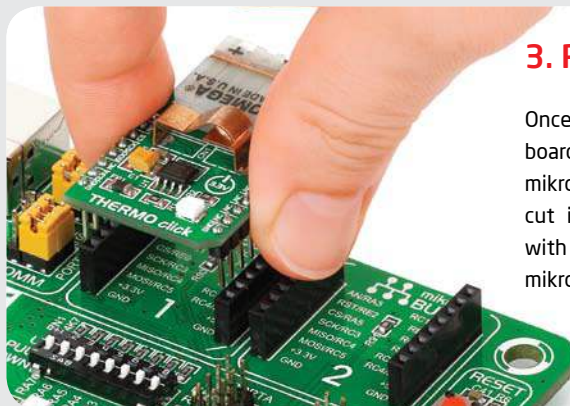

Once you have soldered the headers your board is ready to be placed into desired mikroBUS™ socket. Make sure to align the cut in the lower-right part of the board with the markings on the silkscreen at the mikroBUS™ socket. If all of the pins are aligned correctly, push the board all the way into the socket.

click™
BOARD
www.mikroe.com



Thermo click Manual
ver. 1.00



0 10000 020975

5. THERMO Click™ Board Schematic

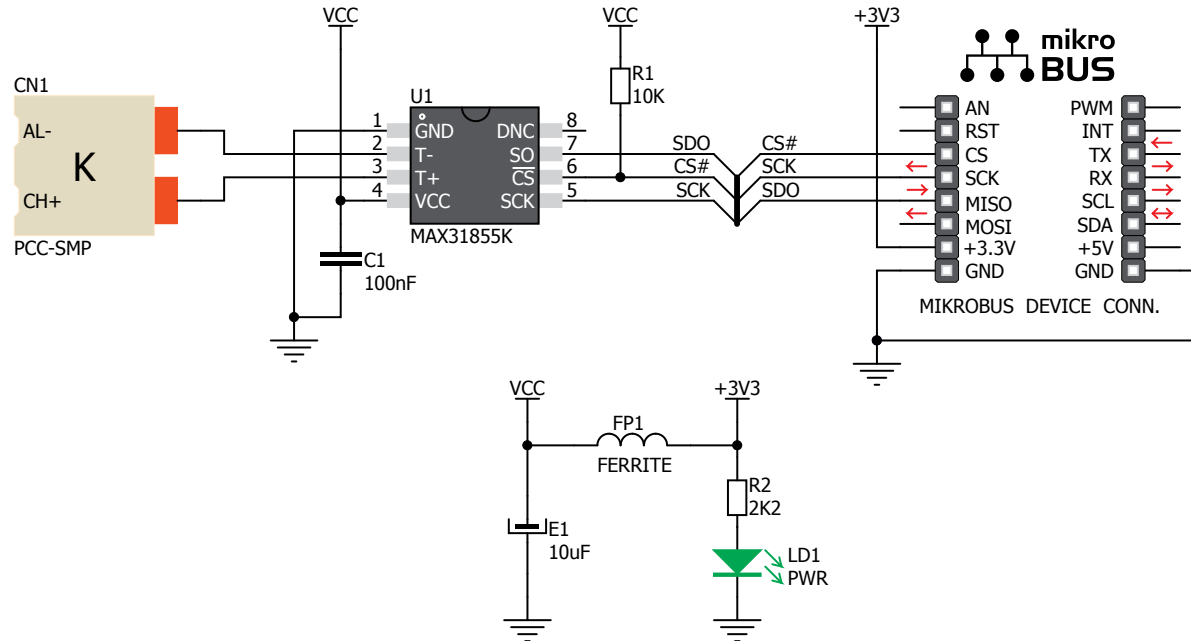

6. Thermocouple probe

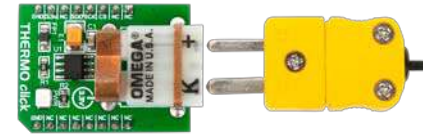

In order to use THERMO Click™ board you need to connect the appropriate K-type thermocouple probe (not included in the package) into the PCC-SMP connector, as shown in figure above.

7. Code Examples

Once you have done all the necessary preparations, it's time to get your click board up and running. We have provided the examples for mikroC, mikroBasic and mikroPascal compilers on our [Libstock](http://www.libstock.com) website. Just download them and you are ready to start.



8. Support

MikroElektronika offers **Free Tech Support** (www.mikroe.com/esupport) until the end of product lifetime, so if something goes wrong, we are ready and willing to help!