

NCV70628

Micro-stepping Motor Driver

Introduction

The NCV70628 is a single-chip micro-stepping motor driver with position controller and control/diagnostic interface. It is ready to build dedicated mechatronics solutions connected remotely with a LIN master.

The chip receives positioning instructions through the bus and subsequently drives the motor coils to the desired position. The on-chip position controller is configurable (OTP or RAM) for different motor types, positioning ranges and parameters for speed, acceleration and deceleration. The NCV70628 acts as a slave on the LIN bus and the master can fetch specific status information like actual position, error flags, etc. from each individual slave node.

An integrated sensor-less step-loss detection prevents the positioner from loosing steps and stops the motor when running into stall. This enables silent, yet accurate position calibrations during a referencing run and allows semi-closed loop operation when approaching the mechanical end-stops.

The chip is implemented in I3T50 technology, enabling both high voltage analog circuitry and digital functionality on the same chip. The NCV70628 is fully compatible with the automotive voltage requirements. Due to the technology, the device is especially suited for use in applications with fluctuating battery supplies.

PRODUCT FEATURES

Motordriver

- Micro-stepping Technology
- Sensorless Step-loss Detection
- Peak Current up to 800 mA
- Low Temperature Boost Current up to 1100 mA
- Programmable Current Stabilization Phase
- Fixed Frequency PWM Current-control
- Automatic Selection of Fast and Slow Decay Mode
- No External Fly-back Diodes Required
- Compliant with 14 V Automotive Systems

Controller with RAM and OTP Memory

- Position Controller
- Configurable Speeds and Acceleration
- Input to Connect Optional Motion Switch

LIN Interface

- Physical Layer Compliant to LIN rev. 2.2. Data-link Layer Compatible with LIN rev. 2.2
- Field-programmable Node Addresses
- Dynamically Allocated Identifiers
- Diagnostics and Status Information



ON Semiconductor®

www.onsemi.com

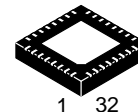

**QFN32, 5x5x1
CASE 484AB**

ORDERING INFORMATION

See detailed ordering, marking and shipping information in the package dimensions section on page 2 of this data sheet.

Protection

- Overcurrent Protection
- Open-circuit Detection
- High Temperature Warning and Management
- Low Temperature Flag
- LIN Bus Short-circuit Protection to Supply and Ground
- Lost LIN Safe Operation
- Enhanced Under Voltage Management

Power Saving

- Powerdown Supply Current < 150 μ A
- 3.3 V Regulator with Wake-up On LIN Activity

EMI Compatibility

- LIN Bus Integrated Slope Control
- HV Outputs with Slope Control
- This is a Pb-Free Device

NCV70628

Applications

The NCV70628 is ideally suited for small positioning applications. Target markets include: automotive (headlamp alignment, HVAC, idle control, cruise control), industrial equipment (lighting, fluid control, labeling, process control, XYZ tables, robots...) and building automation (HVAC,

surveillance, satellite dish, renewable energy systems). Suitable applications typically have multiple axes or require mechatronics solutions with the driver chip mounted directly on the motor.

Table 1. ORDERING INFORMATION

Part No.	Peak Current	End Market/Version	Package*	Shipping†
NCV70628MW001R2G	800/1100 mA (Note 1)	Automotive	QFN32 with step-cut wettable flank (Pb-Free)	5000 / Tape & Reel

*For additional information on our Pb-Free strategy and soldering details, please download the ON Semiconductor Soldering and Mounting Techniques Reference Manual, SOLDERRM/D.

†For information on tape and reel specifications, including part orientation and tape sizes, please refer to our Tape and Reel Packaging Specifications Brochure, BRD8011/D.

1. The device boost current. This applies for operation under the thermal warning level only.

MARKING DIAGRAM

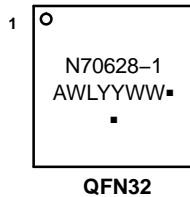

A = Assembly Location
 WL = Wafer Lot
 YY = Year
 WW = Work Week
 G or ■ = Pb-Free Package

(Note: Microdot may be in either location)

Table 2. ABSOLUTE MAXIMUM RATINGS

Parameter		Min	Max	Unit
V _{bb} , V _{hw2} , V _{swi}	Supply voltage, hardwired address pin	-0.3	+40 (Note 2)	V
V _{lin}	Bus input voltage (Note 3)	-40	+40	V
T _J	Junction temperature range (Note 4)	-45	+175	°C
T _{stg}	Storage temperature range (Note 5)	-55	+160	°C
V _{esd} (Note 6)	HBM Electrostatic discharge voltage on LIN pin	-4	+4	kV
	HBM Electrostatic discharge voltage on other pins	-2	+2	kV
	MM Electrostatic discharge voltage on other pins	-200	+200	V

Stresses exceeding those listed in the Maximum Ratings table may damage the device. If any of these limits are exceeded, device functionality should not be assumed, damage may occur and reliability may be affected.

NOTE: A mission profile (Note 4) is a substantial part of the operation conditions; hence the Customer must contact ON Semiconductor in order to mutually agree in writing on the allowed missions profile(s) in the application.

2. For limited time: V_{BB} < 0.5 s, SWI and HW2 pins < 1.0 s.

3. Maximum allowed voltage between two device pins is 60 V.

4. The circuit functionality is not guaranteed outside the Operating junction temperature range.

A mission profile describes the application specific conditions such as, but not limited to, the cumulative operating conditions over life time, the system power dissipation, the system's environmental conditions, the thermal design of the customer's system, the modes, in which the device is operated by the customer, etc.

5. For limited time up to 100 hours. Otherwise the maximum storage temperature is 85°C.

6. HBM according to AEC-Q100: EIA-JESD22-A114-B (100 pF via 1.5 kΩ) and MM according to AEC-Q100: EIA-JESD22-A115-A.

Table 3. OPERATING RANGES

Parameter		Min	Max	Unit
V _{BB}	Supply voltage	+5.5	+29	V
T _{JP}	Parametric Operating junction temperature range (Note 7)	-40	+145	°C
T _{JF}	Functional Operating junction temperature range (Note 8)	-40	+160	°C

7. The parametric characteristics of the circuit are not guaranteed outside the parametric operating junction temperature range.

8. The maximum functional operating temperature range can be limited by thermal shutdown T_{tsd}.

NCV70628

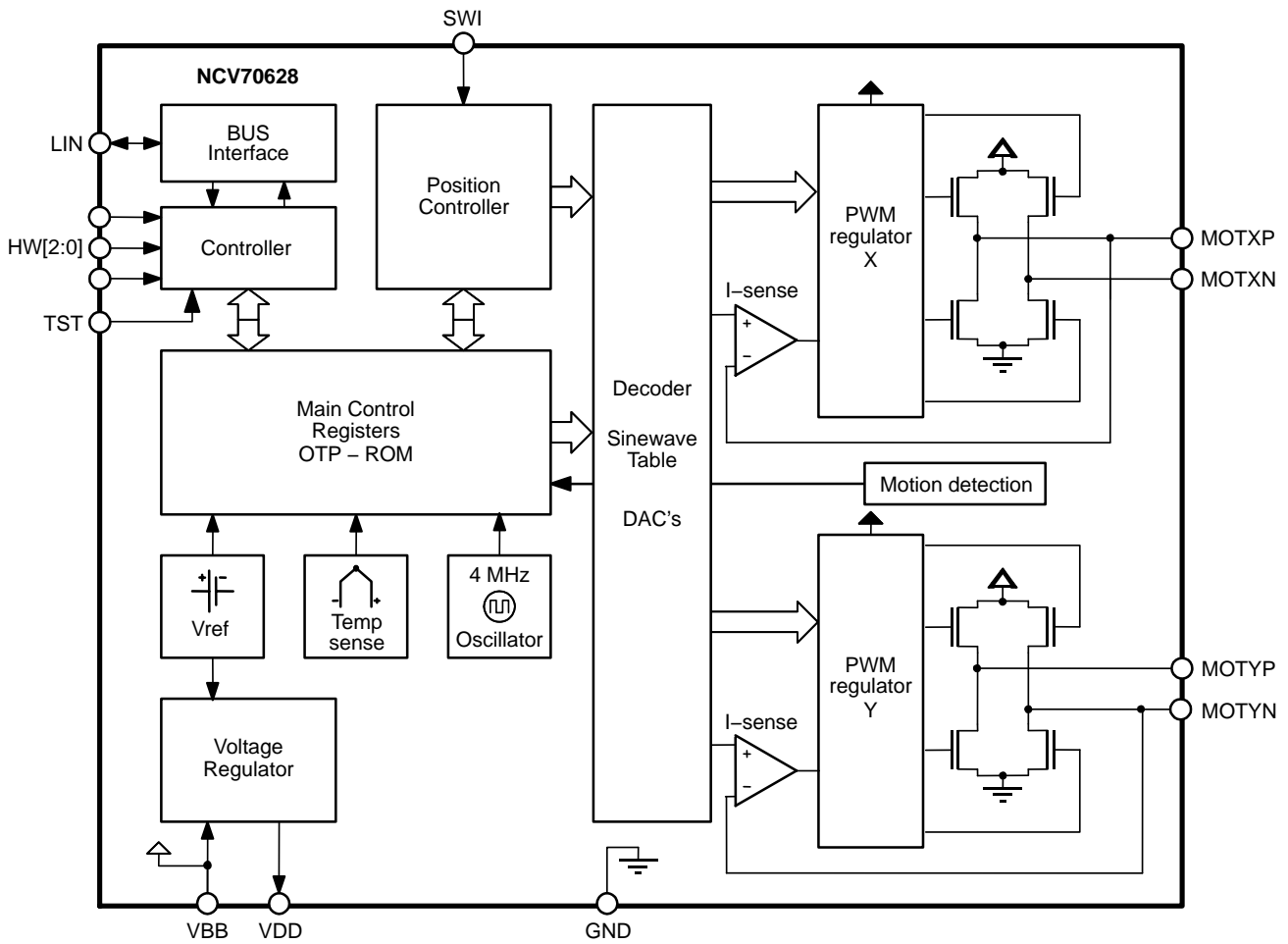

Figure 1. Block Diagram

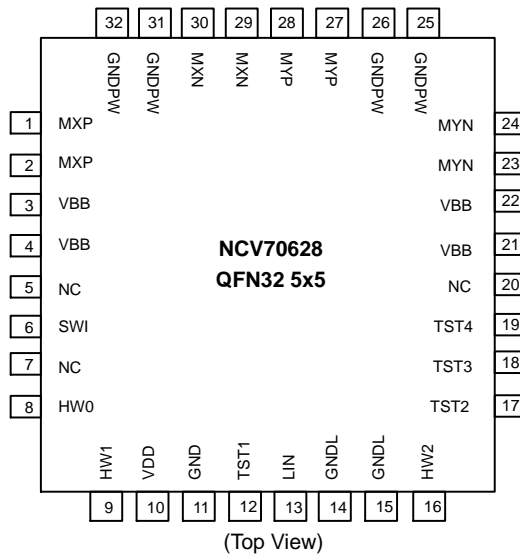

Figure 2. Pinout Diagram

NCV70628

Table 4. PIN DESCRIPTIONS – QFN PACKAGE

Pin No.	Pin Name	Pin Description	
1, 2	MXP	Positive end of phase X coil	
3, 4, 21, 22	VBB	Battery voltage supply	
5, 7, 20	NC	Not used	
6	SWI	Switch input	
8	HW0	Bit 0 of LIN-ADD	To be tied to GND or V _{DD}
9	HW1	Bit 1 of LIN-ADD	
10	VDD	Internal supply (needs external decoupling capacitor)	
11	GND	Ground	
12	TST1	Test pin (to be tied to ground in normal operation)	
13	LIN	LIN-bus connection	
14, 15	GNDL	Ground	
16	HW2	Bit 2 LIN-ADD	
17	TST2	Test pin (to be tied to ground in normal operation)	
18	TST3	Test pin (to be tied to ground in normal operation)	
19	TST4	Test pin (to be tied to ground in normal operation)	
23, 24	MYN	Negative end of phase Y coil	
25, 26, 31, 32	GNDPW	Ground	
27, 28	MYP	Positive end of phase Y coil	
29, 30	MXN	Negative end of phase X coil	

Package Thermal Resistance

The NCV70628 is available in thermally optimized QFN32 package. For the optimizations, the package has an exposed thermal pad which has to be soldered to the PCB ground plane. The ground plane needs thermal vias to

conduct the heat to the bottom layer. Figure 3 gives examples for good power distribution solutions.

The thermal resistances are presented in Table 5: Thermal resistance.

Table 5. THERMAL RESISTANCE

Characteristics	Package	Symbol	Min	Typ	Max	Unit
Thermal Resistance, Junction-to-Exposed Pad (Note 9)	QFN32	R _{θJP}	–	14	–	K/W

9. Also includes typical solder thickness under the Exposed Pad (EP).

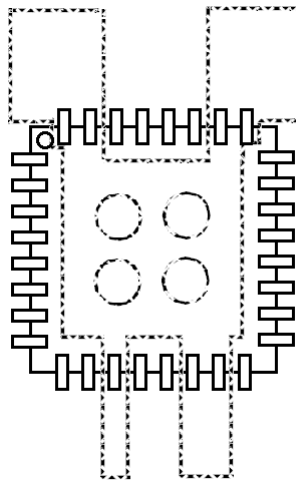

Figure 3. Example of QFN32 PCB Ground Plane Layout. Preferred layout at top and bottom connected with through-hole filled vias

NCV70628

DC Parameters

The DC parameters are guaranteed over junction temperature from -40 to 145°C and V_{BB} in the operating range from 5.5 to 29 V, unless otherwise specified. Convention: currents flowing into the circuit are defined as positive.

Table 6. DC PARAMETERS

Symbol	Pin(s)	Parameter	Test Conditions	Min	Typ	Max	Unit
MOTORDRIVER							
$I_{\text{MS-max,Peak}}$	MOTXP MOTXN MOTYP MOTYN	Max current through motor coil in normal operation	$V_{\text{BB}} = 14 \text{ V}$		800		mA
$I_{\text{MS-max,RMS}}$		Max rms current through coil in normal operation	$V_{\text{BB}} = 14 \text{ V}$		570		mA
I_{MSabs}		Absolute error on coil current (Note 10)	$V_{\text{BB}} = 14 \text{ V}, T_j = 145^{\circ}\text{C}$	-10		10	%
I_{MSrel}		Matching of X & Y coil currents	$V_{\text{BB}} = 14 \text{ V}$	-7	0	7	%
$I_{\text{MS-boost_Peak}}$		Max peak current during booster function	$V_{\text{BB}} = 14 \text{ V}, T < T_{\text{tw}}$		1100		mA
$R_{\text{DS(on)}}$		On resistance of High side + Low side Driver at I_{MSmax}	$T_j \leq 25^{\circ}\text{C}$ $T_j = 145^{\circ}\text{C}$			1.8 2.4	Ω Ω

LIN TRANSMITTER (Note 21)

$I_{\text{bus_off}}$	LIN	Dominant state, driver off	$V_{\text{bus}} = 0 \text{ V}, V_{\text{BB}} = 7 \text{ V} \& 18 \text{ V}$	-1			mA
$I_{\text{bus_off}}$		Recessive state, driver off	$V_{\text{bus}} = V_{\text{bat}}, V_{\text{BB}} = 7 \text{ V} \& 18 \text{ V}$			10	μA
$I_{\text{bus_off}}$		Recessive state, driver off	$V_{\text{BB}} = 0 \text{ V}$ (Note 10)			10	μA
$I_{\text{bus_lim}}$		Current limitation	$V_{\text{BB}} = 7 \text{ V} \& 18 \text{ V}$	40	75	200	mA
$I_{\text{bus_no_gnd}}$		Control unit disconnected from GND	$V_{\text{BB}} = \text{GND} = 18 \text{ V}, V_{\text{bus}} = 0 \& 18 \text{ V}$	-1		1	mA
$I_{\text{bus_no_bat}}$		V_{bat} disconnected	$V_{\text{BB}} = \text{GND} = 0 \text{ V}, V_{\text{bus}} = 0 \& 18 \text{ V}$			100	μA
C_{LIN}		Capacitance on the pin			20	30	pF
R_{slave}		Pullup resistance	$V_{\text{BB}} = 7 \text{ V} \& 18 \text{ V}$	20	30	47	k Ω

LIN RECEIVER (Note 21)

$V_{\text{bus_dom}}$	LIN	Receiver dominant state	$V_{\text{BB}} = 7 \text{ V} \& 18 \text{ V}$	0		$0.4 * V_{\text{BB}}$	V
$V_{\text{bus_rec}}$		Receiver recessive state	$V_{\text{BB}} = 7 \text{ V} \& 18 \text{ V}$	$0.6 * V_{\text{BB}}$		V_{BB}	V
$V_{\text{bus_hys}}$		Receiver hysteresis (Note 11)	$V_{\text{BB}} = 7 \text{ V} \& 18 \text{ V}$	$0.05 * V_{\text{BB}}$		$0.175 * V_{\text{BB}}$	V
$V_{\text{rec_cnt}}$		Receiver center voltage (Note 12)	$V_{\text{BB}} = 7 \text{ V} \& 18 \text{ V}$	$0.475 * V_{\text{BB}}$	$0.5 * V_{\text{BB}}$	$0.525 * V_{\text{BB}}$	V

THERMAL WARNING & SHUTDOWN

T_{tw}		Thermal warning (Notes 13 and 14)	150	157	165	$^{\circ}\text{C}$
T_{tsd}		Thermal shutdown (Note 15)		$T_{\text{tw}} + 10$		$^{\circ}\text{C}$
T_{low}		Low temperature warning (Note 15)		$T_{\text{tw}} - 157$		$^{\circ}\text{C}$

10. Tested in production for 800 mA, 400 mA, 200 mA and 100 mA current settings for both X and Y coil.

11. $V_{\text{bus_hys}} = V_{\text{th_rec}} - V_{\text{th_dom}}$

12. $V_{\text{rec_cnt}} = 1/2 * (V_{\text{th_dom}} + V_{\text{th_rec}})$, $V_{\text{th_dom}}$: receiver threshold of the recessive to dominant LIN bus edge,

$V_{\text{th_rec}}$: receiver threshold of the dominant to recessive LIN bus edge

13. Parameter guaranteed by trimming relevant OTPs in production.

14. No more than 100 cumulated hours in life time above T_{tw} .

15. Thermal shutdown and low temperature warning are derived from thermal warning. Guaranteed by design.

16. A buffer capacitor of minimum 100 μF is needed between V_{BB} and GND. Short connections to the power supply are recommended.

17. Typical value is valid for the junction temperature $< 130^{\circ}\text{C}$

18. Pin V_{DD} must not be used for any external supply

19. The RAM content will not be altered above this voltage.

20. External resistance value seen from pin SW1 or HW2, including 1 k Ω series resistor. For the switch OPEN, the maximum allowed leakage current is represented by a minimum resistance seen from the pin.

21. While LIN is only specified for operation above 7 V V_{BB} , the device can operate LIN at lower voltages down to UV2 voltage level. Under these conditions the LIN specific parameters are not guaranteed.

Table 6. DC PARAMETERS

Symbol	Pin(s)	Parameter	Test Conditions	Min	Typ	Max	Unit
SUPPLY AND VOLTAGE REGULATOR							
V_{bbOTP}	V_{BB}	Supply voltage for OTP zapping (Note 16)		14.0		18.0	V
UV_2		Stop voltage low threshold		5.48	5.90	6.32	V
UV_3	V_{BB}	Decelerated stop voltage low threshold	$UV3Thr[2:0] = 000$	5.48	5.90	6.32	V
			$UV3Thr[2:0] = 001$	5.86	6.30	6.74	V
$UV3Thr[2:0] = 010$			6.23	6.70	7.17	V	
$UV3Thr[2:0] = 011$			6.60	7.10	7.60	V	
UV_3		Decelerated stop voltage low threshold	$UV3Thr[2:0] = 100$	6.97	7.50	8.03	V
			$UV3Thr[2:0] = 101$	7.34	7.90	8.46	V
			$UV3Thr[2:0] = 110$	7.71	8.30	8.89	V
			$UV3Thr[2:0] = 111$	8.09	8.70	9.31	V
UV_1	V_{BB}	Stop voltage high threshold, Ratio metric coupled to $UV3Thr[2:0]$.	$UV3Thr[2:0] = 000$	6.18	6.62	7.06	V
			$UV3Thr[2:0] = 001$	6.60	7.07	7.54	V
			$UV3Thr[2:0] = 010$	7.02	7.52	8.01	V
			$UV3Thr[2:0] = 011$	7.44	7.97	8.49	V
			$UV3Thr[2:0] = 100$	7.86	8.41	8.97	V
			$UV3Thr[2:0] = 101$	8.28	8.86	9.45	V
			$UV3Thr[2:0] = 110$	8.70	9.31	9.93	V
			$UV3Thr[2:0] = 111$	9.12	9.76	10.41	V
I_{bat}		Total current consumption	Unloaded outputs, $V_{BB} = 29\text{ V}$		3.50	10.0	mA
I_{bat_s}		Sleep mode current consumption (Note 17)	$V_{BB} = 5.5\text{ V} \& 18\text{ V}$		65	100	μA
V_{DD}	V_{DD}	Regulated internal supply (Note 18)	$5.5\text{ V} < V_{BB} < 29\text{ V}$	3.0	3.3	3.6	V
		Digital supply reset level @ power down (Note 19)				2.85	V
I_{ddLim}		Current limitation	Pin shorted to ground $V_{BB} = 14\text{ V}$				80

SWITCH INPUT AND HARDWARE ADDRESS INPUT

R_{t_OFF}	SWI HW2	Switch OPEN resistance (Note 20)		10			k Ω
R_{t_ON}		Switch ON resistance (Note 20)	Switch to GND or V_{BB}			1.9	k Ω
V_{bb_sw}		V_{BB} range for guaranteed operation of SWI and HW2		5.5		29	V
I_{lim_sw}		Current limitation	Short to GND or V_{bat} $V_{BB} = 29\text{ V}$	20	30	45	mA

HARDWIRED ADDRESS INPUTS AND TEST PIN

V_{ihigh}	HW0 HW1 TST	Input level high	$V_{BB} = 14\text{ V}$	$0.75 \cdot V_{DD}$			V
V_{ilow}		Input level low	$V_{BB} = 14\text{ V}$			$0.25 \cdot V_{DD}$	V
HW_{hyst}		Hysteresis	$V_{BB} = 14\text{ V}$	$0.3 \cdot V_{DD}$		$0.5 \cdot V_{DD}$	V

10. Tested in production for 800 mA, 400 mA, 200 mA and 100 mA current settings for both X and Y coil.
11. $V_{bus_hys} = V_{th_rec} - V_{th_dom}$
12. $V_{rec_cnt} = 1/2 \cdot (V_{th_dom} + V_{th_rec})$, V_{th_dom} : receiver threshold of the recessive to dominant LIN bus edge, V_{th_rec} : receiver threshold of the dominant to recessive LIN bus edge
13. Parameter guaranteed by trimming relevant OTPs in production.
14. No more than 100 cumulated hours in life time above T_w .
15. Thermal shutdown and low temperature warning are derived from thermal warning. Guaranteed by design.
16. A buffer capacitor of minimum 100 μF is needed between V_{BB} and GND. Short connections to the power supply are recommended.
17. Typical value is valid for the junction temperature $< 130^\circ\text{C}$
18. Pin V_{DD} must not be used for any external supply
19. The RAM content will not be altered above this voltage.
20. External resistance value seen from pin SWI or HW2, including 1 k Ω series resistor. For the switch OPEN, the maximum allowed leakage current is represented by a minimum resistance seen from the pin.
21. While LIN is only specified for operation above 7 V V_{BB} , the device can operate LIN at lower voltages down to UV_2 voltage level. Under these conditions the LIN specific parameters are not guaranteed.

NCV70628

AC Parameters

The AC parameters are guaranteed over junction temperature from -40 to 145°C and V_{BB} in the operating range from 5.5 to 29 V, unless otherwise specified. The LIN transmitter and receiver physical layer parameters are compliant to LIN rev. 2.x.

Table 7. AC PARAMETERS

Symbol	Pin(s)	Parameter	Test Conditions	Min	Typ	Max	Unit
POWERUP							
T_{pu}		Power-up time	Guaranteed by design			10	ms
INTERNAL OSCILLATOR							
f_{osc}		Frequency of internal oscillator	$V_{\text{BB}} = 14 \text{ V}$	3.6	4.0	4.4	MHz
LIN TRANSMITTER CHARACTERISTICS ACCORDING TO LIN V2.x							
D1	LIN	Duty cycle 1 = $t_{\text{Bus_rec(min)}} / (2 \times t_{\text{Bit}})$; See Figure 4	THRec(max) = $0.744 \times V_{\text{BB}}$ THDom(max) = $0.581 \times V_{\text{BB}}$; $V_{\text{BB}} = 7.0 \text{ V} \dots 18 \text{ V}$; $t_{\text{Bit}} = 50 \mu\text{s}$	0.396			
D2		Duty cycle 2 = $t_{\text{Bus_rec(max)}} / (2 \times t_{\text{Bit}})$; See Figure 4	THRec(min) = $0.422 \times V_{\text{BB}}$ THDom(min) = $0.284 \times V_{\text{BB}}$; $V_{\text{BB}} = 7.6 \text{ V} \dots 18 \text{ V}$; $t_{\text{Bit}} = 50 \mu\text{s}$			0.581	
D3		Duty cycle 3 = $t_{\text{Bus_rec(min)}} / (2 \times t_{\text{Bit}})$	THRec(max) = $0.778 \times V_{\text{BB}}$ THDom(max) = $0.616 \times V_{\text{BB}}$; $V_{\text{BB}} = 7.0 \text{ V} \dots 18 \text{ V}$; $t_{\text{Bit}} = 96 \mu\text{s}$	0.417			
D4		Duty cycle 4 = $t_{\text{Bus_rec(max)}} / (2 \times t_{\text{Bit}})$	THRec(min) = $0.389 \times V_{\text{BB}}$ THDom(min) = $0.251 \times V_{\text{BB}}$; $V_{\text{BB}} = 7.6 \text{ V} \dots 18 \text{ V}$; $t_{\text{Bit}} = 96 \mu\text{s}$			0.590	
LIN RECEIVER CHARACTERISTICS ACCORDING TO LIN V2.x							
trx_pdr	LIN	Propagation delay bus dominant to RxD = low	$V_{\text{BB}} = 7.0 \text{ V} \ \& \ 18 \text{ V}$; See Figure 4			6	μs
trx_pdf		Propagation delay bus recessive to RxD = high	$V_{\text{BB}} = 7.0 \text{ V} \ \& \ 18 \text{ V}$; See Figure 4			6	μs
trx_sym		Symmetry of receiver propagation delay	trx_pdr – trx_pdf	-2		+2	μs
SWITCH INPUT AND HARDWARE ADDRESS INPUT							
T_{sw}	SW1 HW2	Scan pulse period (Note 22)	$V_{\text{BB}} = 14 \text{ V}$		1024		μs
$T_{\text{sw_on}}$		Scan pulse duration (Note 22)	$V_{\text{BB}} = 14 \text{ V}$		128		μs

22. Derived from the internal oscillator

23. See [SetMotorParam](#) and [PWM Regulator](#)

Table 7. AC PARAMETERS

Symbol	Pin(s)	Parameter	Test Conditions	Min	Typ	Max	Unit	
MOTORDRIVER								
F _{pwm}	MOTx	PWM frequency (Note 22)	PWMfreq = 0 (Note 23)	20.6	22.8	25.0	kHz	
			PWMfreq = 1 (Note 23)	41.2	45.6	50.0	kHz	
F _{jit_depth}		PWM jitter modulation depth	PWMJen = 1 (Note 23)		10		%	
T _{brise}		Turn-on transient time	Between 10% and 90%		300		ns	
T _{bfall}					300		ns	
T _{stab}		Run current stabilization time (Note 22)		TStab[2:0] = 000	14.4	16	17.6	ms
				TStab[2:0] = 001	19.8	22	24.2	ms
				TStab[2:0] = 010	25.2	28	30.8	ms
	TStab[2:0] = 011			28.8	32	35.2	ms	
	TStab[2:0] = 100			34.2	38	41.8	ms	
	TStab[2:0] = 101			39.6	44	48.4	ms	
	TStab[2:0] = 110			45	50	55	ms	
	TStab[2:0] = 111			50.4	56	61.6	ms	
SUPPLY								
T _{UV1_deb}	VBB	UV1 level debounce time (Note 22)	UV3debT = 0		256		μs	
			UV3debT = 1		2000		μs	

22. Derived from the internal oscillator
 23. See [SetMotorParam](#) and [PWM Regulator](#)

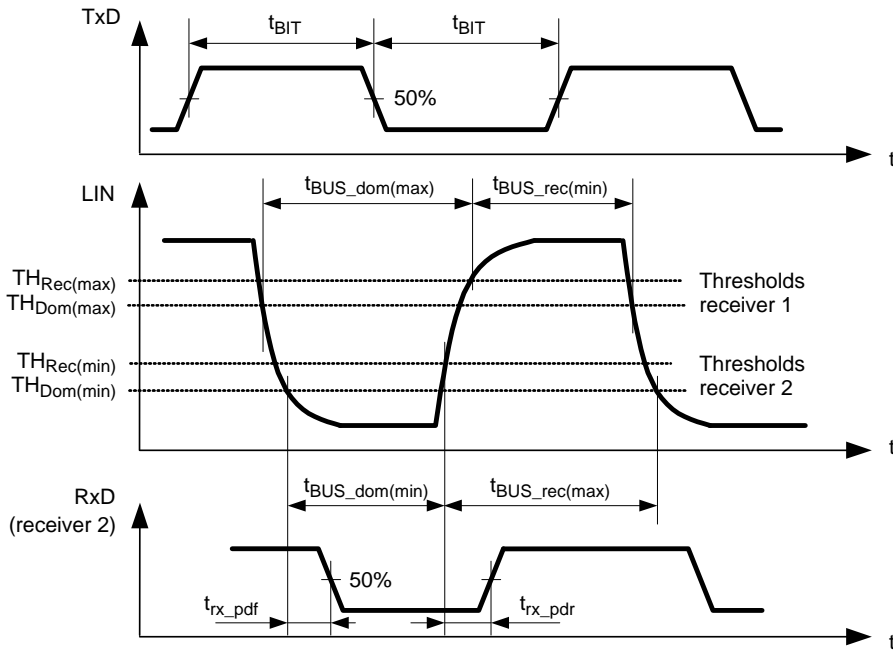

Figure 4. Timing Diagram for AC Characteristics According to LIN 2.x

NCV70628

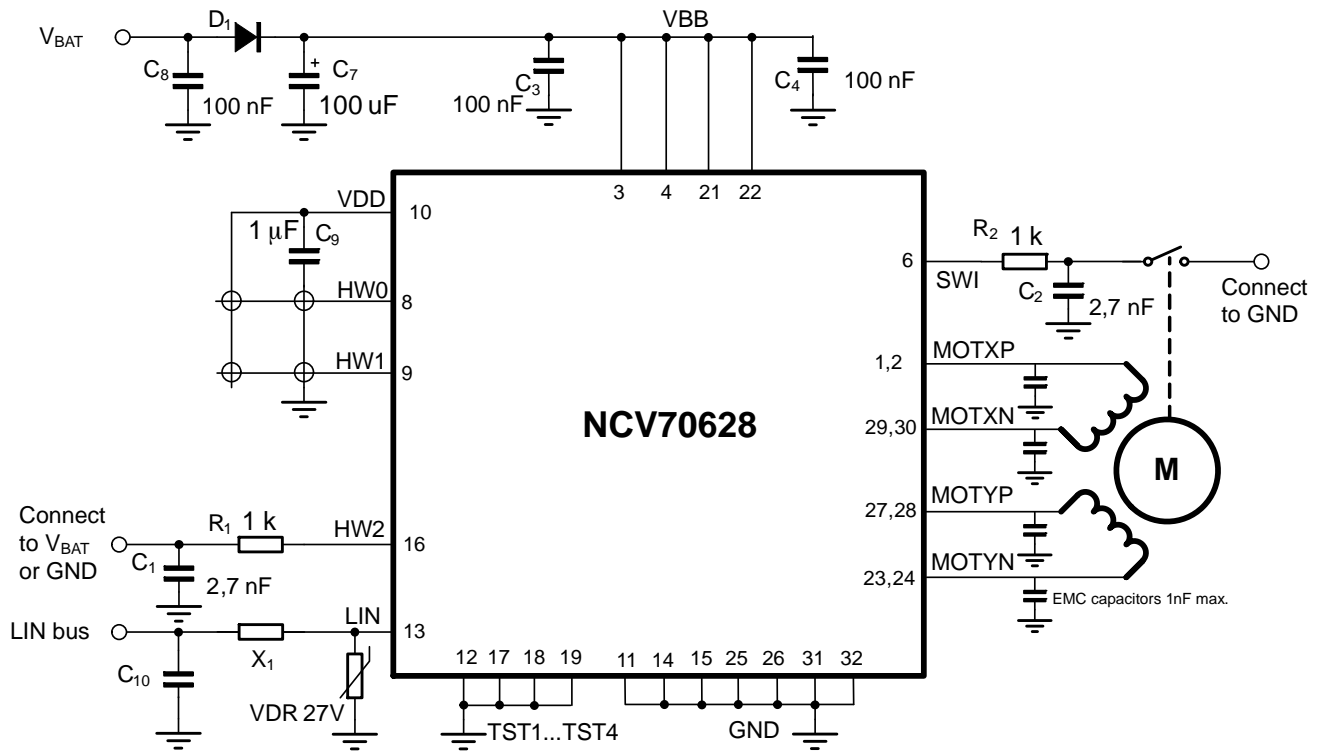

Figure 5. Typical Application

Table 8. APPLICATION DIAGRAM COMPONENT VALUES

Comp	Function	Typ. Value	Tol.	Units	Voltage / Power Dissipation
R ₁	Switch inout protection	1	±5%	kΩ	250 mW
R ₂	Addressing protection	1	±5%	kΩ	250 mW
C ₁	Switch inout filter	2.7	±20%	nF	50 V
C ₂	Addressing inout filter	2.7	±20%	nF	50 V
C ₃	High voltage supply decoupling	100	±20%	nF	50 V
C ₄	High voltage supply decoupling	100	±20%	nF	50 V
C ₆	Low voltage supply decoupling	100	±20%	nF	10 V
C ₇	High voltage supply filter	100	±20%	μF	50 V
C ₈	High voltage supply decoupling	100	±20%	nF	50 V
C ₉	Low voltage supply stabilization	1	±20%	μF	10 V
C ₁₀	EMC filtering capacitors	1	±20%	nF	50 V

NOTES: All resistors are ± 5%, 1/4 W

C₁, C₂ minimum value is 2.7 nF, maximum value is 10 nF

Depending on the application, the ESR value and working voltage of C₇ must be carefully chosen

C₃ and C₄ must be close to pins V_{BB} and coupled GND directly

C₉ must be a ceramic capacitor to assure low ESR

C₁₀ is placed for system level EMC reasons; value depends on EMC requirements of the application, recommended 200 pF

X₁ is placed for system level EMC and ESD reasons. Use e.g. BLM18AG601SN1D 600 OHM or resistor 50 Ω

Positioning Parameters

Stepping Modes

One of four possible stepping modes can be programmed:

- Half-stepping
- 1/4 micro-stepping
- 1/8 micro-stepping
- 1/16 micro-stepping

Maximum Velocity

For each stepping mode, the maximum velocity Vmax can be programmed to 16 possible values given in the table below.

The accuracy of Vmax is derived from the internal oscillator. Under special circumstances it is possible to change the Vmax parameter while a motion is ongoing. All 16 entries for the Vmax parameter are divided into four groups. When changing Vmax during a motion the application must take care that the new Vmax parameter stays within the same group.

Table 9. MAXIMUM VELOCITY SELECTION TABLE

Vmax Index		Vmax (full step/s)	Group	Stepping Mode			
Hex	Dec			Half-stepping (half-step/s)	1/4 th Micro-stepping (micro-step/s)	1/8 th Micro-stepping (micro-step/s)	1/16 th Micro-stepping (micro-step/s)
0	0	99	A	197	395	790	1579
1	1	136	B	273	546	1091	2182
2	2	167		334	668	1335	2670
3	3	197		395	790	1579	3159
4	4	213		425	851	1701	3403
5	5	228		456	912	1823	3647
6	6	243		486	973	1945	3891
7	7	273		C	546	1091	2182
8	8	303	607		1213	2426	4852
9	9	334	668		1335	2670	5341
A	10	364	729		1457	2914	5829
B	11	395	790		1579	3159	6317
C	12	456	912		1823	3647	7294
D	13	546	D		1091	2182	4364
E	14	729		1457	2914	5829	11658
F	15	973		1945	3891	7782	15564

NCV70628

Minimum Velocity

Once the maximum velocity is chosen, 16 possible values can be programmed for the minimum velocity Vmin. The table below provides the obtainable values in full-step/s.

The accuracy of Vmin is derived from the internal oscillator. It is not recommended to change the Vmin while a motion is ongoing.

Table 10. OBTAINABLE VALUES IN FULL-STEP/s FOR THE MINIMUM VELOCITY

Vmin Index		Vmax Factor	Vmax (Full-step/s)															
			A	B					C					D				
Hex	Dec		99	136	167	197	213	228	243	273	303	334	364	395	456	546	729	973
0	0	1	99	136	167	197	213	228	243	273	303	334	364	395	456	546	729	973
1	1	1/32	3	4	5	6	6	7	7	8	8	10	10	11	13	15	19	27
2	2	2/32	6	8	10	11	12	13	14	15	17	19	21	23	27	31	42	57
3	3	3/32	9	12	15	18	19	21	22	25	27	31	32	36	42	50	65	88
4	4	4/32	12	16	20	24	26	28	30	32	36	40	44	48	55	65	88	118
5	5	5/32	15	21	26	31	32	35	37	42	46	51	55	61	71	84	111	149
6	6	6/32	18	25	31	36	39	42	45	50	55	61	67	72	84	99	134	179
7	7	7/32	21	30	36	43	46	50	52	59	65	72	78	86	99	118	156	210
8	8	8/32	24	33	41	49	52	56	60	67	74	82	90	97	113	134	179	240
9	9	9/32	28	38	47	55	59	64	68	76	84	93	101	111	128	153	202	271
A	10	10/32	31	42	51	61	66	71	75	84	93	103	113	122	141	168	225	301
B	11	11/32	34	47	57	68	72	78	83	93	103	114	124	135	156	187	248	332
C	12	12/32	37	51	62	73	79	85	91	101	113	124	135	147	170	202	271	362
D	13	13/32	40	55	68	80	86	93	98	111	122	135	147	160	185	221	294	393
E	14	14/32	43	59	72	86	93	99	106	118	132	145	158	172	198	237	317	423
F	15	15/32	46	64	78	93	99	107	113	128	141	156	170	185	214	256	340	454

NOTES: The Vmax factor is an approximation.

In case of motion without acceleration (**AccShape = 1**) the length of the steps = $1/V_{min}$. In case of accelerated motion (**AccShape = 0**) the length of the first step is shorter than $1/V_{min}$ depending of **Vmin**, **Vmax** and **Acc**.

Acceleration and Deceleration

Sixteen possible values can be programmed for Acc (acceleration and deceleration between Vmin and Vmax). The table below provides the obtainable values in full-step/s². One observes restrictions for some combinations of acceleration index and maximum speed. It

is not recommended to change the Acc value while a motion is ongoing.

The accuracy of Acc is derived from the internal oscillator.

Table 11. ACCELERATION AND DECELERATION SELECTION TABLE

Vmax (FS/s) →		99	136	167	197	213	228	243	273	303	334	364	395	456	546	729	973
↓ Acc Index																	
Hex	Dec	Acceleration (Full-step/s ²)															
0	0	49						106						473			
1	1	218												735			
2	2	1004															
3	3	3609															
4	4	6228															
5	5	8848															
6	6	11409															
7	7	13970															
8	8	16531															
9	9	14785	19092														
A	10		21886														
B	11		24447														
C	12		27008														
D	13		29570														
E	14		29570						34925								
F	15								40047								

The formula to compute the number of equivalent full-steps during acceleration phase is:

$$Nstep = \frac{Vmax^2 - Vmin^2}{2 \times Acc}$$

Positioning

The position programmed in commands SetPosition is given as a number of (micro-) steps. According to the chosen stepping mode, the internal position words is aligned

as described in the table below. The Secure Position is given in a number of two Full Steps. The position data is aligned automatically.

Table 12. POSITION WORD ALIGNMENT

Stepping Mode	Position Word: Pos [15:0]															Shift	
1/16 th	S	B14	B13	B12	B11	B10	B9	B8	B7	B6	B5	B4	B3	B2	B1	LSB	No shift
1/8 th	S	B13	B12	B11	B10	B9	B8	B7	B6	B5	B4	B3	B2	B1	LSB	0	1-bit left ⇔ ×2
1/4 th	S	B12	B11	B10	B9	B8	B7	B6	B5	B4	B3	B2	B1	LSB	0	0	2-bit left ⇔ ×4
Half-stepping	S	B11	B10	B9	B8	B7	B6	B5	B4	B3	B2	B1	LSB	0	0	0	3-bit left ⇔ ×8
Position Short	S	S	S	B9	B8	B7	B6	B5	B4	B3	B2	B1	LSB	0	0	0	No shift
Secure Position	S	B9	B8	B7	B6	B5	B4	B3	B2	B1	LSB	0	0	0	0	0	No shift

NOTES: LSB: Least Significant Bit
S: Sign bit

Position Ranges

A position is coded by using the binary two’s complement format. According to the positioning commands used and to the chosen stepping mode, the position range will be as shown in the following table.

Table 13. POSITION RANGE

Command	Stepping Mode	Position Range	Full Range Excursion	Number of Bits in micro stepping
SetPosition	Half-stepping	-4096 to +4095	8192 half-steps	13
	1/4 th micro-stepping	-8192 to +8191	16384 micro-steps	14
	1/8 th micro-stepping	-16384 to +16383	32768 micro-steps	15
	1/16 th micro-stepping	-32768 to +32767	65536 micro-steps	16

When using the command SetPosition, although coded on 16 bits, the position word is shifted to the left by a certain number of bits, according to the stepping mode.

Secure Position

A secure position can be programmed. It is mapped to the positioned full range but coded in 11-bits, thus having a lower resolution than normal positions, as shown in the following table. See also command GotoSecurePosition and LIN lost behavior.

Table 14. SECURE POSITION

Stepping Mode	Secure Position Resolution
Half-stepping	4 half-steps
1/4 th micro-stepping	8 micro-steps (1/4 th)
1/8 th micro-stepping	16 micro-steps (1/8 th)
1/16 th micro-stepping	32 micro-steps (1/16 th)

Important

NOTES: For the FailSafe functionality and SetDualPosition command, the secure position is disabled in case the programmed value has the code "1000000000" (0x400 or most negative position). For the GotoSecurePosition command there is no disabling possible. By receiving this command the secure positioning is always executed, even when the secure position has the value 0x400.

The resolution of the secure position is limited to 9 bit at start-up. The OTP register is copied in RAM as illustrated below. The RAM bits SecPos1 and SecPos0 are set to 0.

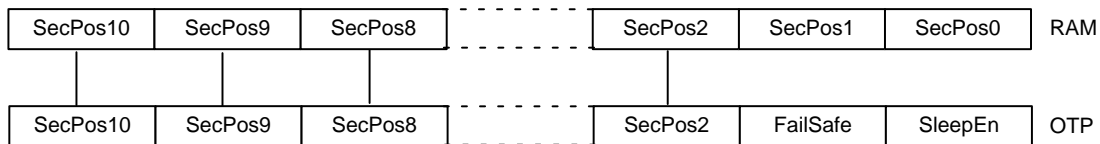

Shaft

A shaft bit, which can be programmed in OTP or with command SetMotorParam, defines whether a positive motion is a clockwise (CW) or counter-clockwise rotation (CCW) (an outer or an inner motion for linear actuators):

- Shaft = 0 ⇒ MOTXP is used as positive pin of the X coil, while MOTXN is the negative one.
- Shaft = 1 ⇒ opposite situation

Structural Description

Refer to the Block Diagram in Figure 1.

Stepper Motordriver

The Motordriver receives the control signals from the control logic. The main features are:

- Two H-bridges, designed to drive a stepper motor with two separated coils. Each coil (X and Y) is driven by one H-bridge, and the driver controls the currents flowing through the coils. The rotational position of the rotor, in unloaded condition, is defined by the ratio of current flowing in X and Y. The torque of the stepper motor when unloaded is controlled by the magnitude of the currents in X and Y.
- The control block for the H-bridges, including the PWM control, the synchronous rectification and the internal current sensing circuitry.
- Two pre-scale 4-bit DAC's to set the maximum magnitude of the current through X and Y.
- Two DAC's to set the correct current ratio through X and Y.
- A boost function that increases the current during cold conditions.

Battery voltage monitoring is also performed by this block, which provides the required information to the control logic part. The same applies for detection and reporting of an electrical problem that could occur on the coils.

Control Logic (Position Controller and Main Control)

The control logic block stores the information provided by the LIN interface (in a RAM or an OTP memory) and digitally controls the positioning of the stepper motor in terms of speed and acceleration, by feeding the right signals to the motor driver state machine.

It will take into account the successive positioning commands to properly initiate or stop the stepper motor in order to reach the set point in a minimum time.

It also receives feedback from the motor driver part in order to manage possible problems and decide on internal actions and reporting to the LIN interface.

Motion Detection

Motion detection is based on the back-emf generated internally in the running motor. When the motor is blocked, e.g. when it hits the end position, the velocity, and as a result also the generated back-emf, is disturbed. The NCV70628 senses the back-emf and compares the value with an independent threshold level. If the back-emf becomes lower than the threshold, the running motor is stopped.

LIN Interface

The LIN interface implements the physical layer and the MAC and LLC layers according to the OSI reference model. It provides and gets information to and from the control logic block, in order to drive the stepper motor, to configure the way this motor must be driven, or to get information such as actual position or diagnosis (temperature, battery voltage, electrical status...) and pass it to the LIN master node.

Miscellaneous

The NCV70628 also contains the following:

- An internal oscillator, needed for the LIN protocol handler as well as the control logic and the PWM control of the motor driver.
- An internal trimmed voltage source for precise referencing.
- A protection block featuring a thermal shutdown and a power-on-reset circuit.
- A 3.3 V regulator (from the battery supply) to supply the internal logic circuitry.

Functions Description

This chapter describes the following functional blocks in more detail:

- Position controller
- Main control and register, OTP memory + ROM
- Motor driver

The Motion detection and LIN controller are discussed in separate chapters.

Position Controller

Positioning and Motion Control

A positioning command will produce a motion as illustrated in Figure 6. A motion starts with an acceleration phase from minimum velocity (V_{min}) to maximum velocity (V_{max}) and ends with a symmetrical deceleration. This is

defined by the control logic according to the position required by the application and the parameters programmed by the application during the configuration phase. The current in the coils is also programmable.

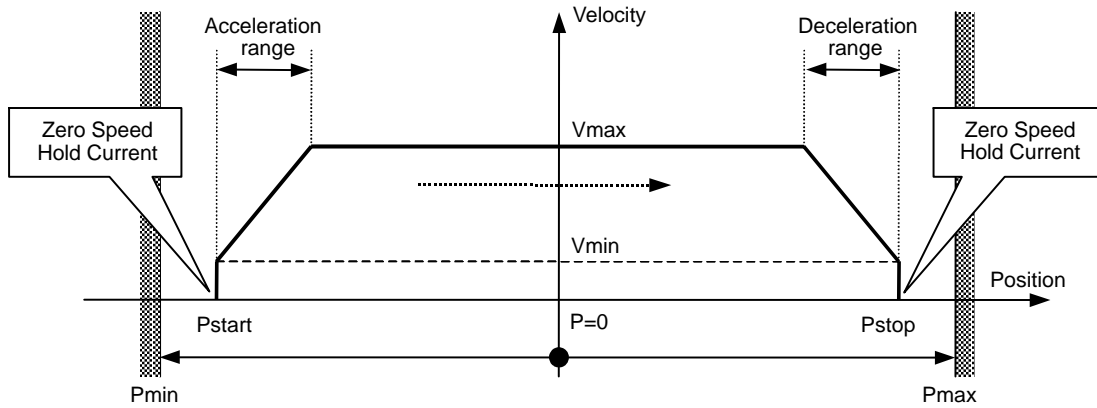

Figure 6. Position and Motion Control

Table 15. POSITION RELATED PARAMETERS

Parameter	Reference
$P_{max} - P_{min}$	See Positioning
Zero Speed Hold Current	See Ihold
Maximum Current	See Irun
Acceleration and Deceleration	See Acceleration and Deceleration
V_{min}	See Minimum Velocity
V_{max}	See Maximum Velocity
Stabilization Time	See Stabilization Time

Different positioning examples are shown in the next table.

Table 16. POSITIONING EXAMPLES

<p>Short motion.</p>	
<p>New positioning command in same direction, shorter or longer, while a motion is running at maximum velocity.</p>	
<p>New positioning command in same direction while in deceleration phase (Note 24) Note: there is no wait time between the deceleration phase and the new acceleration phase.</p>	
<p>New positioning command in reverse direction while motion is running at maximum velocity.</p>	
<p>New positioning command in reverse direction while in deceleration phase.</p>	
<p>New velocity Vmax programming while motion is running.</p>	

24. Reaching the end position is always guaranteed, however velocity rounding errors might occur. The device is automatically compensating the position error. The velocity rounding error will be removed at Vmin (e.g. at end of acceleration or when AccShape=1) by a corrective motion action.

Dual Positioning

A SetDualPosition command allows the user to perform a positioning using two different velocities. The first motion is done with the specified Vmin and Vmax velocities in the SetDualPosition command, with the acceleration (deceleration) parameter already in RAM, to a position Pos1 [15:0] also specified in SetDualPosition.

Then a second relative motion to a physical position Pos1 [15:0] + Pos2 [15:0] is done at the specified Vmin velocity in the SetDualPosition command (no

acceleration). Once the second motion is achieved, the ActPos register is reset to zero, whereas TagPos register is cleared (or set to SecPos value when Secure Position is enabled).

When the Secure position is enabled, after the dual positioning, the secure positioning is executed. The figure below gives a detailed overview of the dual positioning function. After the dual positioning is executed an internal flag is set to indicate the NCV70628 is referenced.

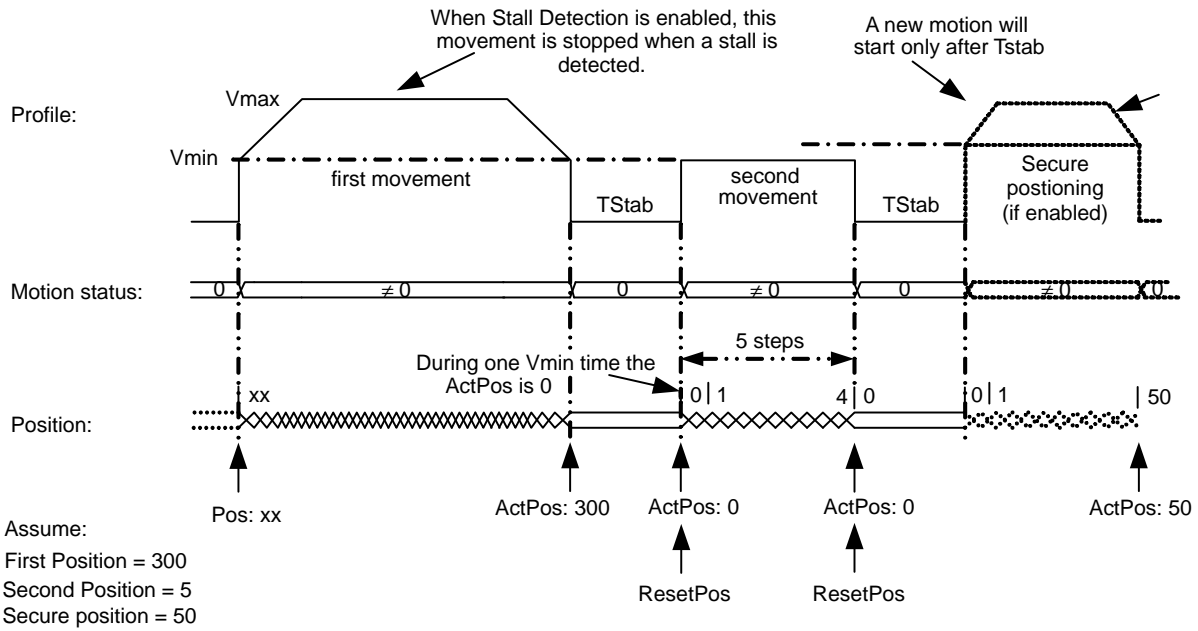

Figure 7. Dual Position

Remark: This operation cannot be interrupted or influenced by any further command unless the occurrence of the conditions driving to a motor shutdown or by a HardStop command. Sending a SetDualPosition command while a motion is already ongoing is not recommended.

25. The priority encoder is describing the management of states and commands.
26. A DualPosition sequence starts by setting TagPos buffer register to SecPos value, provided secure position is enabled otherwise TagPos is reset to zero. If a SetPosition command is issued during a DualPosition sequence, it will be kept in the position buffer memory and executed afterwards. This applies also for the commands Sleep, SetPosParam and GotoSecurePosition.
27. Commands such as GetActualPos or GetFullStatus will be executed while a Dual Positioning is running. This applies also for all LIN standard diagnostic and configuration frames.
28. The Pos1, Pos2, Vmax and Vmin values programmed in a SetDualPosition command apply only for this sequence. All other motion parameters are used from the RAM registers (programmed for instance by a former SetMotorParam command). After the DualPosition motion is completed, the former Vmin and Vmax become active again.
29. Commands ResetPosition, SetDualPosition, and SoftStop will be ignored while a DualPosition sequence is ongoing, and will not be executed afterwards.
30. Recommendation: a SetMotorParam command should not be sent during a SetDualPosition sequence: all the motion parameters defined in the command, except Vmin and Vmax, become active immediately.
31. When during the Dual positioning an under voltage UV2 or UV3 happens, the motor will stop (hardstop for UV2 or softstop for UV3). The device will go into the under-voltage and autarkic operational handler function (refer to battery voltage management and autarkic function). Especially for the dual positioning it should be stated that after passing the UV1 level the motion is continued with the parameters Vmax, Vmin and Acceleration from RAM registers and not from the SetDualPosition command.

Position Periodicity

Depending on the stepping mode the position can range from -4096 to +4095 in half-step to -32768 to +32767 in 1/16th micro-stepping mode. One can project all these positions lying on a circle. When executing the command SetPosition, the position controller will set the movement direction in such a way that the traveled distance is minimal.

The figure below illustrates that the moving direction going from ActPos = +30000 to TagPos = -30000 is clockwise.

If a counter clockwise motion is required in this example, several consecutive SetPosition commands can be used.

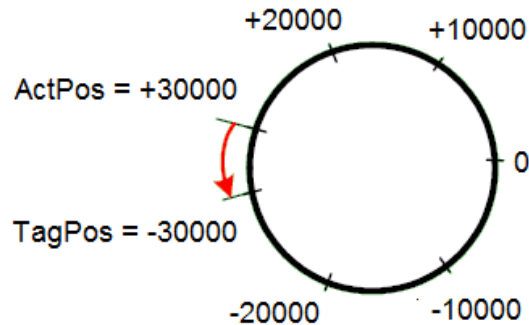

Figure 8. Motion Direction is Function of the Difference between ActPos and TagPos

Hardwired Address HW2

In the drawing below, a simplified schematic diagram is shown of the HW2 comparator circuit.

The HW2 pin is sensed via 2 switches. The DriveHS and DriveLS control lines are alternatively closing the top and bottom switch connecting HW2 pin with a current to resistor converter. Closing S_{TOP} (DriveHS = 1) will sense a current

to GND. In that case the top I → R converter output is low, via the closed passing switch S_{PASS_T} this signal is fed to the “R” comparator which output HW2_Cmp is high. Closing bottom switch S_{BOT} (DriveLS = 1) will sense a current to V_{BAT} . The corresponding I → R converter output is low and via S_{PASS_B} fed to the comparator. The output HW2_Cmp will be high.

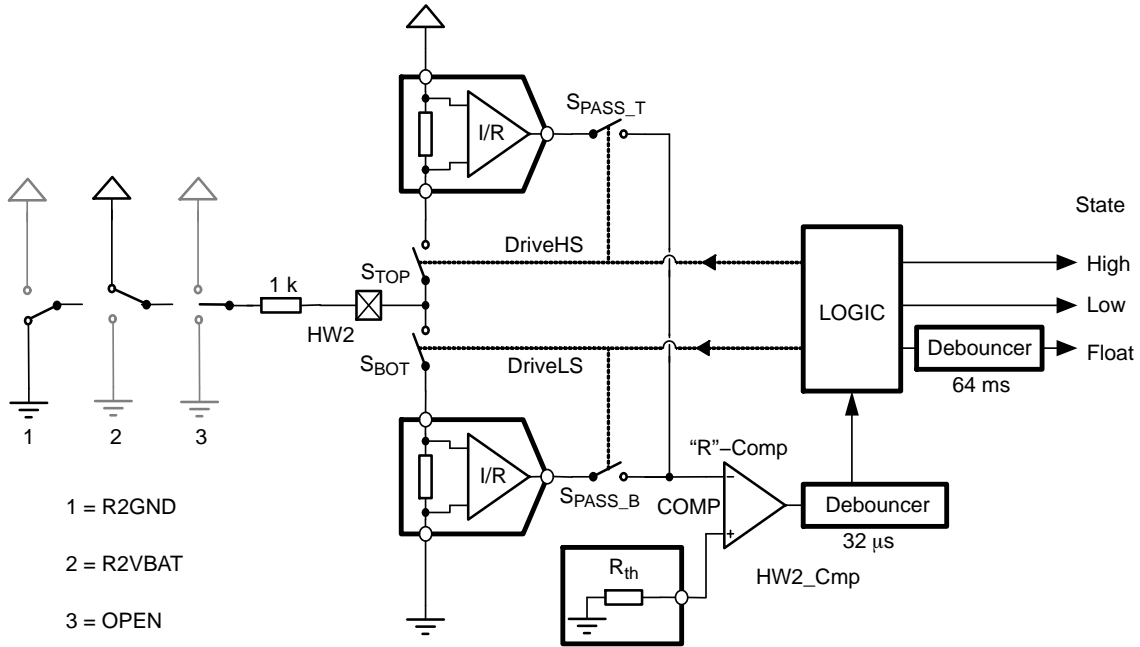

Figure 9.

3 cases can be distinguished (see also Figure 9 above):

- HW2 is connected to ground: R2GND or drawing 1
- HW2 is connected to VBAT: R2VBAT or drawing 2
- HW2 is floating: OPEN or drawing 3

Table 17. STATE DIAGRAM OF THE HW2 COMPARATOR

Previous State	DriveLS	DriveHS	HW2_Cmp	New State	Condition	Drawing
Float	1	0	0	Float	R2GND or OPEN	1 or 3
Float	1	0	1	High	R2VBAT	2
Float	0	1	0	Float	R2VBAT or OPEN	2 or 3
Float	0	1	1	Low	R2GND	1
Low	1	0	0	Low	R2GND or OPEN	1 or 3
Low	1	0	1	High	R2VBAT	2
Low	0	1	0	Float	R2VBAT or OPEN	2 or 3
Low	0	1	1	Low	R2GND	1
High	1	0	0	Float	R2GND or OPEN	1 or 3
High	1	0	1	High	R2VBAT	2
High	0	1	0	High	R2VBAT or OPEN	2 or 3
High	0	1	1	Low	R2GND	1

The logic is controlling the correct sequence in closing the switches and in interpreting the 32 μ s debounced HW2_Cmp output accordingly. The output of this small state-machine is corresponding to:

- High or address = 1
- Low or address = 0
- Floating

As illustrated in the table above (Table 17), the state is depending on the previous state, the condition of the 2 switch controls (DriveLS and DriveHS) and the output of HW2_Cmp. Figure 10 shows an example of a practical case where a connection to VBAT is interrupted.

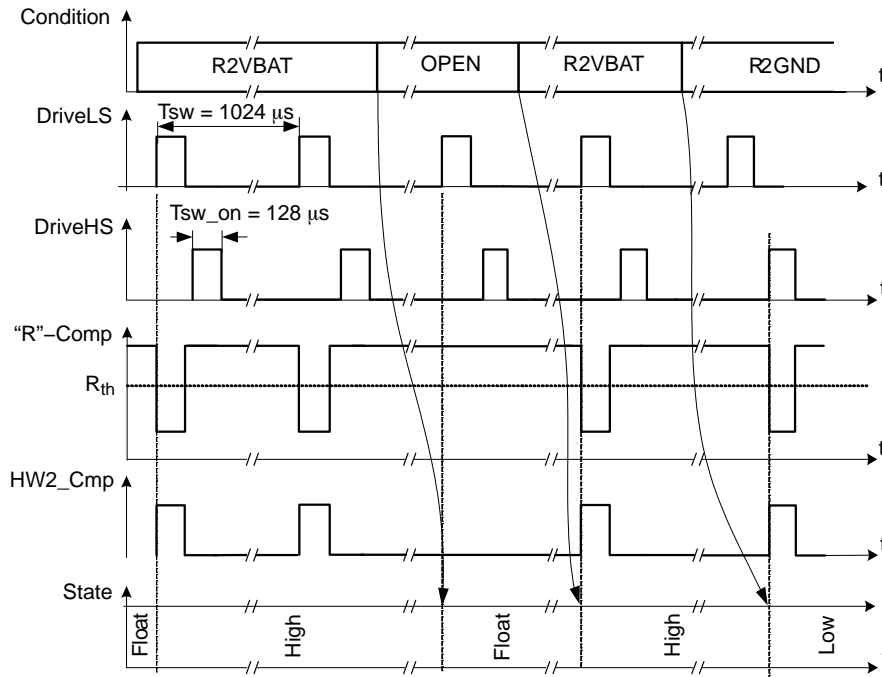

Figure 10. Timing Diagram Showing the Change in State for HW2 Comparator

R2VBAT

A resistor is connected between VBAT and HW2. Every 1024 μ s S_{BOT} is closed and a current is sensed. The output of the $I \Rightarrow R$ converter is low and the HW2_Cmp output is high. Assuming the previous state was floating, the internal logic will interpret this as a change of state and the new state will be high (see also Table 17). The next time S_{BOT} is closed the same conditions are observed. The previous state was high so based on Table 17 the new state remains unchanged. This high state will be interpreted as HW2 address = 1.

OPEN

In case the HW2 connection is lost (broken wire, bad contact in connector) the next time S_{BOT} is closed, this will be sensed. There will be no current, the output of the corresponding $I \Rightarrow R$ converter is high and the HW2_Cmp will be low. The previous state was high. Based in Table 17 one can see that the state changes to float. This will trigger

a motion to secure position after a debounce time of 64 ms, which prevents false triggering in case of micro-interruptions of the power supply.

R2GND

If a resistor is connected between HW2 and the GND, a current is sensed every 1024 μ s when S_{TOP} is closed. The output of the top $I \Rightarrow R$ converter is low and as a result the HW2_Cmp output switches to high. Again based on the stated diagram in Table 17 one can see that the state will change to Low. This low state will be interpreted as HW2 address = 0.

External Switch SWI

As illustrated in Figure 11 the SWI comparator is almost identical to HW2. The major difference is in the limited number of states. Only open or closed is recognized leading to respectively $ESW = 0$ and $ESW = 1$.

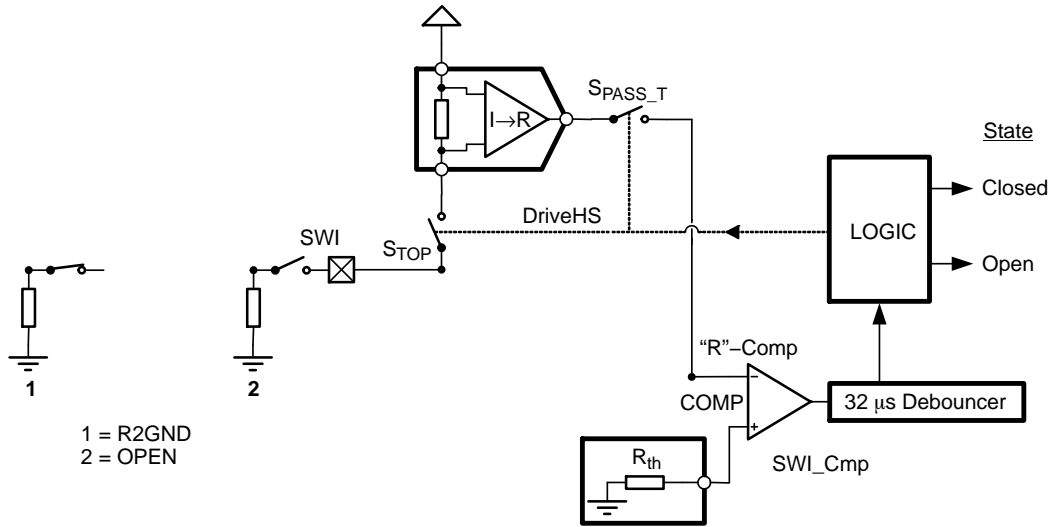

Figure 11. Simplified Schematic Diagram of the SWI Comparator

As illustrated in the drawing above, a change in state is always synchronized with DriveHS or DriveLS. The same synchronization is valid for updating the internal position register. This means that after every current pulse (or closing of S_{TOP} or S_{BOT}) the state of the position switch together with the corresponding position is memorized.

The `GetActualPos` command reads back the `<ActPos>` register and the status of ESW. In this way the master node may get synchronous information about the state of the switch together with the position of the motor. See Table 18 below.

Table 18. GetActualPos READING FRAME

Byte	Content	Structure							
		Bit 7	Bit 6	Bit 5	Bit 4	Bit 3	Bit 2	Bit 1	Bit 0
0	PID	PID(6)							
1	Data 1	ActPos[7:0]							
2	Data 2	ActPos[15:8]							
3	Data 3	ESW	StepLoss	EIDef	UV	TSD	TW	Tinfo[1:0]	
4	Data 4	Motion[2:0]			Stall	LIN_E	UV2	UV3	VddReset
5	Checksum	Enhanced Checksum							

NCV70628

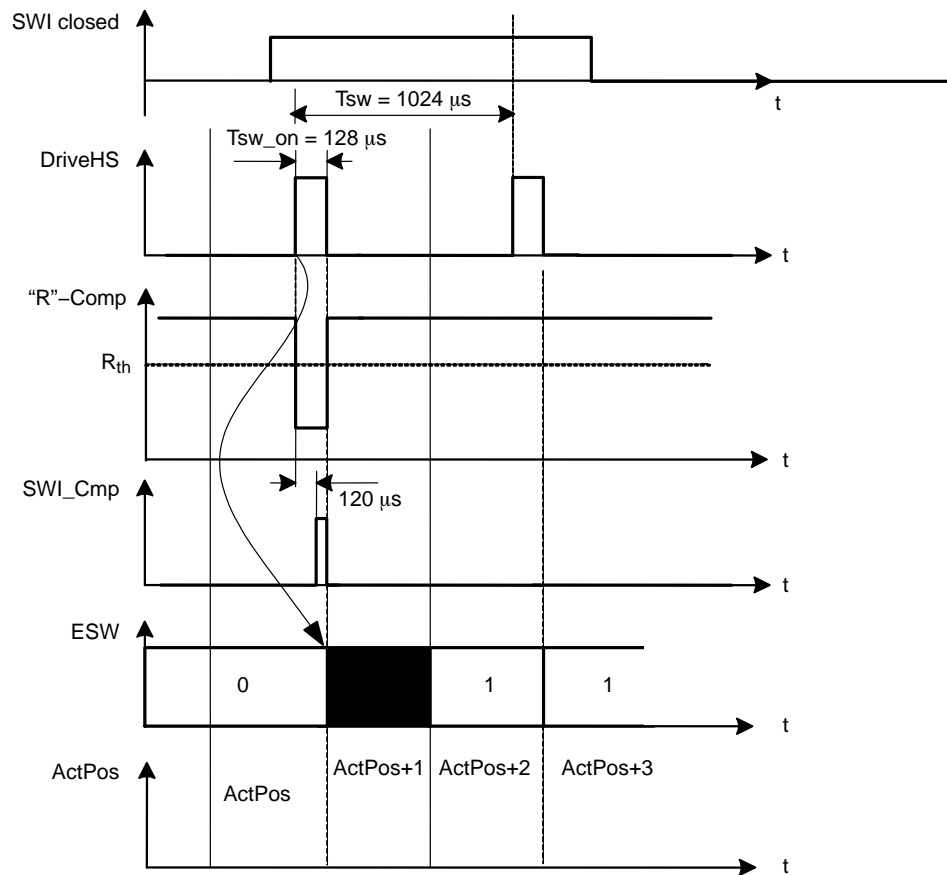

Figure 12. Timing Diagram Showing the Change in States for SWI Comparator

Main Control and Register, OTP memory + ROM

Power-up Phase

Power-up phase of the NCV70628 will not exceed 10 ms. After this phase, the NCV70628 is in standby mode, ready to receive LIN messages and execute the associated commands. After power-up, the registers and flags are in the reset state, while some of them are being loaded with the OTP memory content (see Table 21: RAM Registers).

Reset

After power-up, or after a reset occurrence (e.g. a micro-cut on pin V_{BB} has made V_{DD} to go below V_{ddReset} level), the H-bridges will be in high-impedance mode, and the registers and flags will be in a predetermined position. This is documented in Table 21: RAM Registers and Table 22: Flags Table.

Soft-stop

A soft-stop is an immediate interruption of a motion, but with a deceleration phase. At the end of this action, the register <TagPos> is loaded with the value contained in register <ActPos>, (see Table 21: Ram Registers). The circuit is then ready to execute a new positioning command, provided thermal and electrical conditions allow for it.

Sleep Mode

When entering sleep mode, the stepper-motor can be driven to its secure position. After which, the circuit is

completely powered down, apart from the LIN receiver, which remains active to detect a dominant state on the bus. In case sleep mode is entered while a motion is ongoing, a transition will occur towards secure position as described in Positioning and Motion Control provided <SecPos> is enabled. Otherwise, <SoftStop> is performed.

Sleep mode can be entered in the following cases:

- The circuit receives a LIN go to sleep command (frame with identifier 0x3C and first data byte containing 0x00, as required by LIN specification rev. 2.2 and <SleepEn> bit = 1. See also Sleep in the LIN Application Command section.
- In case the <SleepEn> bit = 1 and the LIN bus remains inactive (or is lost) during more than 4.46 s, a time-out signal switches the circuit to sleep mode.

The circuit will return to normal mode if a valid LIN frame is received. During sleep mode the digital part of NCV70628 is powered off so all internal registers and LIN related settings are cleared. Pre-load of internal registers from OTPs is executed after wake-up from sleep mode. For more information see LIN wake-up functionality description.

Thermal Shutdown Mode

When thermal shutdown occurs, the circuit performs a <SoftStop> command and goes to motor shutdown mode (see Figure 13: State Diagram Temperature Management).

Temperature Management

The NCV70628 monitors temperature by means of two thresholds and one shutdown level, as illustrated in the state diagram and illustration of Figure 13: State Diagram Temperature Management below. The only condition to

reset flags <TW> and <TSD> (respectively thermal warning and thermal shutdown) is to be at a temperature lower than T_{tw} and to get the occurrence of a GetStatus or a GetFullStatus LIN frame.

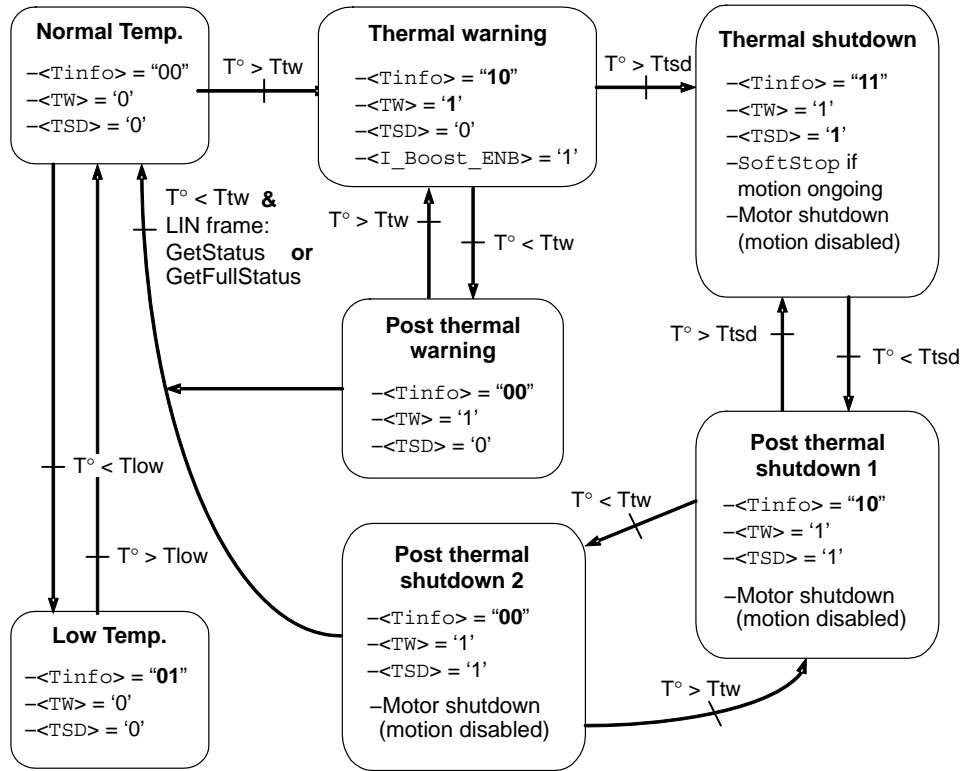

Figure 13. State Diagram Temperature Management

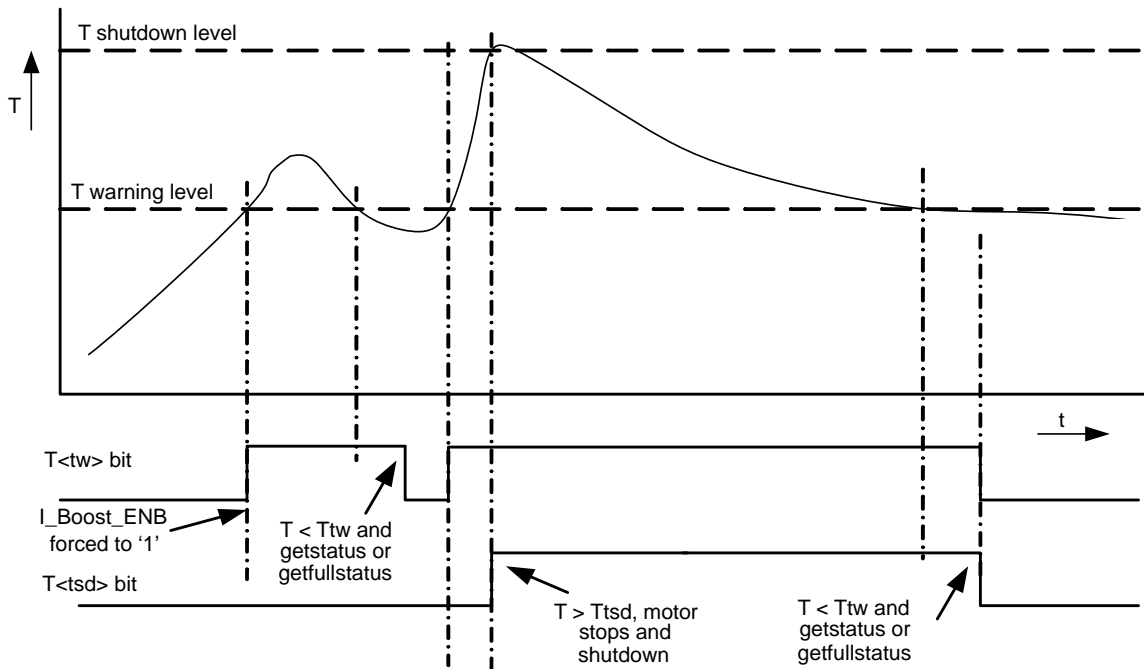

Figure 14. Illustration of Thermal Management Situation

Under-Voltage Condition and Autarkic Functionality

Battery Voltage Management

The NCV70628 monitors the V_{BB} voltage by means of two under voltage threshold UV3 and UV2 and one shutdown level. The only condition to go back to normal operation is to recover by a V_{BB} voltage higher than UV1. The flags <UV2> and <UV3> can only be cleared by receiving the header of a GetStatus or a GetFullStatus command after the V_{BB} voltage higher than UV1.

The UV3 and UV1 levels are programmable by a LIN command. There are 8 levels available for the UV3 threshold voltage. The UV1 level is ratio metric coupled with UV3. UV2 has only a fixed threshold level. Refer to the DC parameter table for the different under voltage levels.

When the battery voltage drops below UV3, the <UV3> flag will be set and a Soft Stop is performed to stop the motion. If during this decelerated motion the battery voltage does not go under the UV2 level, the NCV70628 will go to state <StoppedUnder UV1>” and the original Target Position (TagPos) is saved while the motor is kept in position by the Hold current*. As soon as the V_{BB} voltage rises above the UV1 level the NCV70628 will continue the motion the (TagPos) and will go to the normal <Stopped> state afterwards.

When during a motion the battery voltage drops below the UV2 level, the NCV70628 will stop immediately by a Hard Stop and directly enters the state <HardUnder> followed by <ShutUnder>. The motor is placed in HiZ and the flags <UV2> and <Steploss> are set (see Figure 15).

Note*: In this situation the <Steploss> flag is not set.

Remarks:

If V_{BB} voltage drops below the UV2 level while the NCV70628 is in the motion “stabilization phase”, only the <UV2> flag is set; the <Steploss> flag is not set.

When the NCV70628 is in a stopped states <Stopped> or <StoppedUnder UV1> and the V_{BB} voltage drops below UV2 level, the device will directly go to the state <ShutUnder>, but does not raise the <Steploss> flag.

At the UV3 comparator output, there is implemented an unsymmetrical debouncer which will filter immediate actions during unwanted spikes at the battery supply. For transitions, when supply voltage V_{BB} drops below UV3 level, a 32 μ s debouncer is implemented that is derived from the internal oscillator. For transitions when supply voltage

V_{BB} rises above UV1 level, the NCV70628 reacts after 256 μ s debounce time typically (OTP bit UV3debT is not set). This time is increased to 2 ms when OTP bit UV3debT is zapped to “1”. Zapping can be done via the SetOTPparam command.

Autarkic Function

From above described states the device can enter the state <ShutUnder>. When in the <ShutUnder> state, the device will perform the Autarkic Function:

- If in this state V_{BB} becomes $> UV1$ within 15 seconds, the NCV70628 still will resume the motion to the saved (TagPos) and will go to the <Stopped> state afterwards. It accepts updates of the target position by means of the commands SetPosition, SetPosition2motors, SetPosParam and GotoSecurePosition, even if the <UV2> flag and <Steploss> flags are NOT cleared.
- If however the V_{BB} voltage remains below UV2 level voltage level for more than 15 seconds, the device will enter <Shutdown> state and the target position is overwritten by Actual Position. This state can be exited only if V_{BB} is $> UV1$ voltage level and an incoming command GetStatus or GetFullStatus is received.

Important Notes:

1. In the case of Autarkic positioning, care needs to be taken because accumulated steploss can cause a significant deviation between physical and stored actual position.
2. The SetDualPosition command will only be executed after clearing the <UV2> and <Steploss> flags.
3. RAM reset occurs when $V_{dd} < V_{ddReset}$ (digital Power-On-Reset level).
4. The Autarkic function remains active as long as $V_{DD} > V_{ddReset}$.
5. LIN timeout is not being monitored in Autarkic mode in <ShutUnder> state to avoid LIN lost procedure activation in Autarkic mode or right after $V_{dd} > UV1$ (LIN communication is disabled when $V_{dd} < UV2$).

OTP Register

OTP Memory Structure

The table below shows how the parameters to be stored in the OTP memory are located.

Table 19. OTP MEMORY STRUCTURE

Address	Bit 7	Bit 6	Bit 5	Bit 4	Bit 3	Bit 2	Bit 1	Bit 0
0x00	TSD2	TSD1	TSD0	IREF4	IREF3	IREF2	IREF1	IREF0
0x01	SecPosA	ADM	BG4	BG3	BG2	BG1	BG0	TSD3
0x02	AbsThr3	AbsThr2	AbsThr1	AbsThr0	PA3	PA2	PA1	PA0
0x03	Irun3	Irun2	Irun1	Irun0	lhold3	lhold2	lhold1	lhold0
0x04	Vmax3	Vmax2	Vmax1	Vmax0	Vmin3	Vmin2	Vmin1	Vmin0
0x05	SecPos10	SecPos9	SecPos8	Shaft	Acc3	Acc2	Acc1	Acc0
0x06	SecPos7	SecPos6	SecPos5	SecPos4	SecPos3	SecPos2	Failsafe	SleepEn
0x07	UV3debT	UV3Thr2	UV3Thr1	UV3Thr0	StepMode1	StepMode0	LOCKBT	LOCKBG
0x08	SecPos10A	SecPos9A	SecPos8A	OSC4	OSC3	OSC2	OSC1	OSC0
0x09	SecPos7A	SecPos6A	SecPos5A	SecPos4A	SecPos3A	SecPos2A	FailsafeA	SleepEnA

Parameters stored at address 0x00[6:0], 0x01[5:0], 0x08[4:0] and bit <LOCKBT> are already programmed in the OTP memory at circuit delivery. They correspond to the calibration of the circuit and are just documented here as an indication.

Each OTP bit is at '0' when not zapped. Zapping a bit will set it to '1'. Thus only bits having to be at '1' must be zapped. Zapping of a bit already at '1' is disabled. Each OTP byte will be programmed separately (see command SetOTPparam). Once OTP programming is completed, bit <LOCKBG> can be zapped to disable future zapping, otherwise any OTP bit at '0' could still be zapped by using a SetOTPparam command.

Table 20. OTP OVERWRITE PROTECTION

Lock Bit	Protected Bytes
LOCKBT (factory zapped before delivery)	0x00[6:0], 0x01[5:0], 0x08[4:0]
LOCKBG	0x00 to 0x09

The command used to load the application parameters via the LIN bus in the RAM prior to an OTP Memory programming is SetMotorParam. This allows for a functional verification before using a SetOTPparam command to program and zap separately one OTP memory byte. A GetOTPparam command issued after each SetOTPparam command allows verifying the correct byte zapping.

Note: Zapped bits will become active only after a power cycle. After programming the LIN bits the power cycle has to be performed first to guarantee further communication with the device at the new address.

Application Parameters Stored in OTP Memory

Except for the physical address <PA[3:0]> these parameters, although programmed in a non-volatile memory can still be overwritten in RAM by a LIN SetMotorParam writing operation.

PA[3:0] In combination with HW[2:0] it forms the physical address NAD[7:0] of the stepper-motor. Up to 125 stepper-motors can theoretically be connected to the same LIN bus.

AbsThr[3:0] Absolute threshold used for the motion detection

Index	AbsThr			AbsThr level (V) (*)
0	0	0	0	Disable
1	0	0	1	0.6
2	0	0	1	1.3
3	0	0	1	1.9
4	0	1	0	2.6
5	0	1	0	3.2
6	0	1	1	3.9
7	0	1	1	4.5
8	1	0	0	5.1
9	1	0	0	5.8
A	1	0	1	6.4
B	1	0	1	7.1
C	1	1	0	7.7
D	1	1	0	8.3
E	1	1	1	9.0
F	1	1	1	9.6

(*) Not tested in production. Values are approximations.

UV3Thr [2 : 0] Under voltage threshold voltage for UV3 and UV1.

Index	UV3Thr			UV3 Level	UV1 Level
0	0	0	0	5.90	6.62
1	0	0	1	6.30	7.07
2	0	1	0	6.70	7.52
3	0	1	1	7.10	7.97
4	1	0	0	7.50	8.41
5	1	0	1	7.90	8.86
6	1	1	0	8.30	9.31
7	1	1	1	8.70	9.76

IrUn[3:0] Current amplitude value to be fed to each coil of the stepper-motor. The table below provides the 16 possible values for <IRUN>.

Index	IrUn					Run Current (mA)	Run Boost Current (mA)
0	0	0	0	0	0	59	81
1	0	0	0	1	1	71	98
2	0	0	1	0	0	84	116
3	0	0	1	1	1	100	138
4	0	1	0	0	0	119	164
5	0	1	0	1	1	141	194
6	0	1	1	0	0	168	231
7	0	1	1	1	1	200	275
8	1	0	0	0	0	238	327
9	1	0	0	1	1	283	389
A	1	0	1	0	0	336	462
B	1	0	1	1	1	400	550
C	1	1	0	0	0	476	655
D	1	1	0	1	1	566	778
E	1	1	1	0	0	673	925
F	1	1	1	1	1	800	1100

Shaft This bit distinguishes between a clock-wise or counter-clock-wise rotation.

SecPos[10:2] Secure Position of the stepper-motor. This is the position to which the motor is driven in case of a LIN communication loss or when the LIN error-counter overflows. If <SecPos[10:2]> = "100 0000 00xx", secure positioning is disabled. The stepper motor will be kept in the position occupied at the moment these events occur (does not affect GoToSecurePosition command).

Note: The Secure Position is coded on 11 bits only, providing actually the most significant bits of the position, the non coded least significant bits being set to '0'. The Secure

Ihold[3:0] Hold current for each coil of the stepper-motor. The table below provides the 16 possible values for <IHOLD>.

Index	Ihold					Hold Current (mA)	Hold Boost Current (mA)
0	0	0	0	0	0	59	81
1	0	0	0	1	1	71	98
2	0	0	1	0	0	84	116
3	0	0	1	1	1	100	138
4	0	1	0	0	0	119	164
5	0	1	0	1	1	141	194
6	0	1	1	0	0	168	231
7	0	1	1	1	1	200	275
8	1	0	0	0	0	238	327
9	1	0	0	1	1	283	389
A	1	0	1	0	0	336	462
B	1	0	1	1	1	400	550
C	1	1	0	0	0	476	655
D	1	1	0	1	1	566	778
E	1	1	1	0	0	673	925
F	1	1	1	1	1	0	0

Note: When the motor is stopped, the current is reduced from <IRUN> to <IHOLD>. In the case of 0 mA hold current (1111 in the hold current table), the following sequence is applied:

1. The current is first reduced to 59 mA or 81 mA during I_Boost function (corresponding to 0000 value in the table).
2. The PWM regulator is switched off; the bottom transistors of the bridges are grounded.

Step Mode Setting of step modes.

Step Mode		Step Mode
0	0	1/2 stepping
0	1	1/4 stepping
1	0	1/8 stepping
1	1	1/16 stepping

Position in OTP has only 9 bits. The two least significant bits are loaded as '0' to RAM when copied from OTP.

SecPosA If <SecPosA> = 0 then <SecPos[10:2]>, <Failsafe> and <SleepEn> stored in bytes 0x05 and 0x06 are used during operation
 If <SecPosA> = 1 then <SecPos[10:2]>, <Failsafe> and <SleepEn> stored in bytes 0x08 and 0x09 are used during operation

Programming SecPosA with "1" makes the OTP bytes 0x05 and 0x06 obsolete. In this case the OTP bytes at 0x08 and 0x09 will be read at the positions of bytes 0x05 and 0x06 when reading the OTP via the GetOTPparam command.

NCV70628

Vmax[3:0] Maximum velocity

Index	Vmax				Vmax(full step/s)	Group
0	0	0	0	0	99	A
1	0	0	0	1	136	B
2	0	0	1	0	167	
3	0	0	1	1	197	
4	0	1	0	0	213	
5	0	1	0	1	228	
6	0	1	1	0	243	
7	0	1	1	1	273	C
8	1	0	0	0	303	
9	1	0	0	1	334	
A	1	0	1	0	364	
B	1	0	1	1	395	
C	1	1	0	0	456	
D	1	1	0	1	546	D
E	1	1	1	0	729	
F	1	1	1	1	973	

Vmin[3:0] Minimum velocity.

Index	Vmin				Vmax Factor
0	0	0	0	0	1
1	0	0	0	1	1/32
2	0	0	1	0	2/32
3	0	0	1	1	3/32
4	0	1	0	0	4/32
5	0	1	0	1	5/32
6	0	1	1	0	6/32
7	0	1	1	1	7/32
8	1	0	0	0	8/32
9	1	0	0	1	9/32
A	1	0	1	0	10/32
B	1	0	1	1	11/32
C	1	1	0	0	12/32
D	1	1	0	1	13/32
E	1	1	1	0	14/32
F	1	1	1	1	15/32

Acc[3:0] Acceleration and deceleration between Vmax and Vmin.

Index	Acc				Acceleration (Full-step/s ²)
0	0	0	0	0	49 (*)
1	0	0	0	1	218 (*)
2	0	0	1	0	1004 .
3	0	0	1	1	3609 .
4	0	1	0	0	6228 .
5	0	1	0	1	8848 .
6	0	1	1	0	11409 .
7	0	1	1	1	13970 .
8	1	0	0	0	16531 .
9	1	0	0	1	19092 (*)
A	1	0	1	0	21886 (*)
B	1	0	1	1	24447 (*)
C	1	1	0	0	27008 (*)
D	1	1	0	1	29570 (*)
E	1	1	1	0	34925 (*)
F	1	1	1	1	40047 (*)

(*) restriction on speed

SleepEn IF <SleepEn> = 1 -> NCV70628 always goes to low-power sleep mode incase of LIN timeout.

IF <SleepEn> = 0, there is no more automatic transition to low-current sleep mode (i.e. stay in stop mode with applied hold current, unless there are failures). Exception to this rule are the states <Standby> and <Shutdown>, in which the device can enter sleep regardless of the state of SleepEn.

Note: The <SleepEn> function acts for the LIN Go to sleep command too. When <SleepEn> = 1 and the Go to sleep command is received the NCV70628 will go into Sleep. In case the <SleepEn> = 0 the NCV70628 will go into stop mode.

FailSafe

Description: see section LIN Lost Behavior.

ADM <ADM> controls how the OTP bits and hardwired LIN address bits are combined into the LIN node address (see also LIN Address section).

UV3DepT Debounce time after passing the UV1 level of the rising battery voltage slope. The debouce time is specified in the AC parameter table.

Table 21. RAM REGISTERS

Register	Mnemonic	Length (bit)	Related Commands	Comment	Reset State
Actual position	ActPos	16	GetActualPos GetFullStatus GotoSecurePosition ResetPosition	16-bit signed	
Last programmed Position	Pos/TagPos	16/11	GetFullStatus GotoSecurePosition ResetPosition SetPosition SetPosition2Motors SetPosParam	16-bit signed or 11-bit signed for half stepping (see Positioning)	
Acceleration shape	AccShape	1	GetFullStatus SetMotorParam SetStallParam	'0' ⇒ normal acceleration from Vmin to Vmax '1' ⇒ motion at Vmin without acceleration	'0'
Coil peak current	Irun	4	GetFullStatus SetMotorParam SetStallParam	Operating current See look-up table Irun	From OTP memory
Coil hold current	Ihold	4	GetFullStatus SetMotorParam SetStallParam	Standstill current See look-up table Ihold	
Minimum Velocity	Vmin	4	GetFullStatus SetMotorParam SetPosParam SetStallParam	See Section Minimum Velocity See look-up table Vmin	
Maximum Velocity	Vmax	4	GetFullStatus SetMotorParam SetPosParam SetStallParam	See Section Maximum Velocity See look-up table Vmax	
Shaft	Shaft	1	GetFullStatus SetMotorParam SetStallParam	Direction of movement	
Acceleration/ deceleration	Acc	4	GetFullStatus SetMotorParam SetPosParam SetStallParam	See Section Acceleration See look-up table Acc	
Secure Position	SecPos	11	GetFullStatus SetMotorParam	Target position when LIN connection fails; 11 MSB's of 16-bit position (LSB's fixed to '0')	
Stepping mode	StepMode	2	GetFullStatus SetStallParam SetStallParam	See Section Stepping Modes See look-up table StepMode	
Stall detection absolute threshold	AbsThr	4	GetFullStatus SetStallParam SetPosParam	The B-emf voltage threshold level at which stall is detected.	
Under voltage UV3	UV3Thr	3	GetFullStatus SetStallParam	Under voltage UV3 and UV1 level	
Sleep Enable	SleepEn	1	SetOTPParam	Enables entering sleep mode after LIN lost. See also LIN lost behavior	
Fail Safe	FailSafe	1	SetOTPParam	Triggers autonomous motion after LIN lost at POR. See also LIN lost behavior	
Stall detection delay	FS2StallEn	3	GetFullStatus SetStallParam	Delays the stall detection after acceleration	'000'
Stall detection sampling	MinSamples	4	GetFullStatus SetStallParam	Duration of the zero current step in number of PWM cycles.	'0000'
PWM Jitter	PWMJEn	1	GetFullStatus SetStallParam	'1' means jitter is added	'0'

Table 21. RAM REGISTERS

Register	Mnemonic	Length (bit)	Related Commands	Comment	Reset State
100% duty cycle Stall Enable	DC100StEn	1	GetFullStatus SetStallParam	'1' means stall detection is enabled in case PWM regulator runs at $\delta = 100\%$	'0'
PWM frequency	PWMFreq	1	GetFullStatus SetMotorParam	'0' means ~ 22 KHz, '1' means ~ 44 KHz	'0'
Boost function	I_BOOST_ENB	1	GetFullStatus SetMotorParam	'0' means boost function is enabled. See also Motor current boost function	'1'
Stabilization time	Tstab	3	GetFullStatus SetMotorParam	See also Motor stopping phase and Motion detection	'011'

Table 22. FLAGS TABLE

Flag	Mnemonic	Length (bit)	Related Commands	Comment	Reset State
LIN Timeout Error	TimE	1	GetFullStatus	Timeout error occurred	'0'
LIN Data Error	DataE	1	Internal use	'1' when one of the three errors occurred: checksum error, stop bit error or frame length error	'0'
LIN Header Error	HeadE	1	GetFullStatus	PID Parity error or PID stop bit error occurred	'0'
LIN Bit Error	BitE	1	Internal use	'1' when received bit value is different from the one being transmitted	'0'
LIN Response Error	LIN_E	1	GetActualPos GetFullStatus	LIN response error occurred (Checksum error, Stop bit error, Frame length error or difference in bit sent and bit monitored on LIN bus)	'0'
Electrical defect	EIDef	1	GetActualPos GetStatus GetFullStatus	<OVC1> or <OVC2> or 'open-load on coil X' or 'open-load on coil Y' Resets only after Get(Full)Status	'0'
External switch status	ESW	1	GetActualPos GetStatus GetFullStatus	'0' = open '1' = close	'0'
Electrical flag	HS	1	Internal use	<UV2> or <EIDef> or <VDDreset>	'0'
Motion status	Motion	3	GetActualPos GetFullStatus	"000" = Stop, last movement was inner (CCW) motion "100" = Stop, last movement was outer (CW) motion "001" = inner (CCW) motion acceleration "010" = inner (CCW) motion deceleration "011" = inner (CCW) motion max. speed "101" = outer (CW) motion acceleration "110" = outer (CW) motion deceleration "111" = outer (CW) motion max. speed	"000"
Over current in coil X	OVC1	1	GetFullStatus	'1' = over current; reset only after GetFullStatus	'0'
Over current in coil Y	OVC2	1	GetFullStatus	'1' = over current; reset only after GetFullStatus	'0'
Secure position enabled	SecEn	1	Internal use	'0' if <SecPos> = "100 0000 0000" '1' otherwise	n.a.
Circuit going to Sleep mode	Sleep	1	Internal use	'1' = Sleep mode reset by LIN command	'0'
Step loss	StepLoss	1	GetActualPos GetStatus GetFullStatus	'1' = step loss due to under voltage, over current, open circuit or stall; Resets only after Get (Full) Status	'1'
Absolute Stall	AbsStall	1	GetFullStatus	'1' = $V_{bemf} < AbsThr$	'0'
Stall	Stall	1	GetActualPos GetFullStatus GetStatus		'0'
Motor stop	Stop	1	Internal use		'0'

Table 22. FLAGS TABLE

Flag	Mnemonic	Length (bit)	Related Commands	Comment	Reset State
Temperature info	Tinfo	2	GetActualPos GetStatus GetFullStatus	"00" = normal temperature range "01" = low temperature warning "10" = high temperature warning "11" = motor shutdown	"00"
Thermal shutdown	TSD	1	GetActualPos GetStatus GetFullStatus	'1' = shutdown ($T_j > T_{tsd}$) Resets only after Get(Full)Status and if <Tinfo> = "00"	'0'
Thermal warning	TW	1	GetActualPos GetStatus GetFullStatus	'1' = over temperature ($T_j > T_{tw}$) Resets only after Get(Full)Status and if <Tinfo> = "00"	'0'
Battery decelerated stop voltage	UV3	1	GetActualPos GetStatus GetFullStatus	'0' = $V_{BB} > UV3$ '1' = $V_{BB} \leq UV3$ Resets only after reception of header of Get(Full)Status and if $V_{BB} > UV1$	'0'
Battery hard stop voltage	UV2	1	GetActualPos GetStatus GetFullStatus	'0' = $V_{BB} > UV2$ '1' = $V_{BB} \leq UV2$ Resets only after reception of header of Get(Full)Status and if $V_{BB} > UV1$	'0'
Overall UV flag	UV	1	GetActualPos GetStatus GetFullStatus	Is the OR function of UV2 and UV3 Resets only after reception of header of Get(Full)Status and if $V_{BB} > UV1$	'0'
Digital supply reset	VddReset	1	GetActualPos GetStatus GetFullStatus	Set at '1' after power-up of the circuit. If this was due to a supply micro-cut, it warns that the RAM contents may have been lost; can be reset to '0' with a Get-Status or a Get(Full)Status command	'1'
Back EMF voltage	BEMF_OUT	5	GetBemf	Result of last back EMF measurement $BEMF_OUT = (v_{MOTdiff} * R_{div_gain} * 5/4 * 2^5) / 2,41$	"00000"
BEMF_OUT affected by 100% duty cycle	BEMF_DC100	1	GetBemf	Set to '1' if last back EMF measurement was performed under 100% PWM duty cycle conditions.	'0'

Priority Encoder

The table below describes the simplified state management performed by the main control block.

Table 23. PRIORITY ENCODER (See table notes on the following page.)

State →	Standby	Stopped	GotoPos	Dual Position	SoftStop	HardStop	ShutDown	Sleep	HardUnder	ShutUnder
Command ↓		Motor Stopped, hold in Coils	Motor Motion Ongoing	No Influence on RAM and TagPos	Motor Decelerating	Motor Forced to Stop	Motor Stopped, H-bridges in Hi-Z	No Power (Note 32)		
GetActualPos	LIN in-frame response	LIN in-frame response	LIN in-frame response	LIN in-frame response	LIN in-frame response	LIN in-frame response	LIN in-frame response		LIN in-frame response	LIN in-frame response
GetOTParam	LIN in-frame response	LIN in-frame response	LIN in-frame response	LIN in-frame response	LIN in-frame response	LIN in-frame response	LIN in-frame response		LIN in-frame response	LIN in-frame response
GetFullStatus or GetStatus [attempt to clear <TSD> and <HS> flags]	LIN in-frame response; if (<TSD> or <HS>) = '0' then → Stopped	LIN in-frame response	LIN in-frame response	LIN in-frame response	LIN in-frame response	LIN in-frame response	LIN in-frame response; if (<TSD> or <HS>) = '0' then → Stopped		LIN in-frame response	LIN in-frame response
SetMotorParam [Master takes care about proper update]	RAM update	RAM update	RAM update	RAM update	RAM update	RAM update	RAM update		RAM update	RAM update
ResetPosition		<TagPos> and <ActPos> reset					<TagPos> and <ActPos> reset			<TagPos> and <ActPos> reset
SetPosition		<TagPos> updated; → GotoPos	<TagPos> updated	<TagPos> updated after DualPosition						
SetPosition 2Motors		<TagPos> updated; → GotoPos	<TagPos> updated	<TagPos> updated after DualPosition						
GotoSec Position		<TagPos> = <SecPos>; → GotoPos	<TagPos> = <SecPos>							
DualPosition		→ Dual Position								
SoftStop			→ SoftStop							
Sleep or LIN timeout [⇒ <Sleep> = '1', reset by any LIN command received later]	→ Sleep	(Note 39)	If <SecEn> = '1' then <TagPos> = <SecPos> else → Soft-Stop	If <SecEn> = '1' then <Tag Pos> = <SecPos>; evaluated after DualPosition	No action; <Sleep> flag evaluated when motor stops	No action; <Sleep> flag evaluated when motor stops	→ Sleep		No action; <Sleep> flag evaluated when motor stops	→ Sleep (LIN timeout ignored)
HardStop			→ Hard Stop	→ Hard Stop	→ Hard Stop					
V _{BB} < UV2 and t > 15 seconds		→ Hard Under	→ Hard Under	→ Hard Stop	→ Hard Under					
V _{BB} < UV2 and t < 15 seconds										→ Stopped
<ElDef> = '1' ⇒ <HS> = '1'		→ Shutdown	→ HardStop; <StepLoss> = '1'	→ HardStop; <StepLoss> = '1'	→ HardStop; <StepLoss> = '1'					→ Shutdown
Thermal shutdown [<TSD> = '1']		→ Shutdown	→ SoftStop	→ SoftStop						→ Shutdown
Motion finished		n.a.	→ Stopped	→ Stopped	→ Stopped; <TagPos> = <ActPos> Goto stopped only if V _{bb} > UV1	→ Stopped; <TagPos> = <ActPos> <StepLoss> = 1	n.a.	n.a.	→ ShutUnder	n.a.

With the Following Color Code:

<input type="checkbox"/> Command Ignored	<input type="checkbox"/> Transition to Another State	<input type="checkbox"/> Master is responsible for proper update (see Note 37)
--	--	--

32. Leaving <Sleep> state is equivalent to power-on-reset.
33. After power-on-reset, the <Standby> state is entered.
34. A Dual Position sequence runs with a separate set of RAM registers. The parameters that are not specified in a Dual Position command are loaded with the values stored in RAM at the moment the Dual Position sequence starts. <AccShape> is forced to '1' during second motion. <AccShape> at '0' will be taken into account after the Dual Position sequence. A GetFullStatus command will return the default parameters for <Vmax> and <Vmin> stored in RAM.
35. The <Sleep> flag is set to '1' when LIN timeout or GotoSleep command occurs. It is reset by the next LIN command (<Sleep> is cancelled if not activated yet).
36. Shutdown state can be left only when <TSD> and <HS> flags are reset.
37. Flags can be reset only after the master could read them via a GetStatus or GetFullStatus command, and provided the physical conditions allow for it (normal temperature, correct battery voltage and no electrical defect).
38. A SetMotorParam command sent while a motion is ongoing (state <GotoPos>) should not attempt to modify <Acc> and <Vmin> values. This can be done during a Dual Position sequence since this motion uses its own parameters, the new parameters will be taken into account at the next SetPosition or SetPosition2Motors command.
39. Some transitions like <GotoPos> → <Sleep> are actually done via several states: <GotoPos> → <SoftStop> → <Stopped> → <Sleep> (see diagram below).
40. Two transitions are possible from state <Stopped> when <Sleep> = '1':
 - 1) Transition to state <Sleep> if <SleepEn> = '0' and (<SecEn> = '0' or secure position reached or <Stop> = '1').
 - 2) Otherwise transition to state <GotoPos>, with <TagPos> = <SecPos>
41. <Stop> flag allows distinguishing whether state <Stopped> was entered after HardStop/SoftStop or not. <Stop> is set to '1' when leaving state <HardStop> or <SoftStop> and is reset during first clock edge occurring in state <Stopped>.
42. Assign PID range command is decoded in all states except <Sleep> and has no effect on the current state. This applies for all standard LIN diagnostic and configuration frames.
43. While in state <Stopped>, if <ActPos> is not equal to <TagPos> there is a transition to state <GotoPos>. This transition has the lowest priority, meaning that <Sleep>, <Stop>, <TSD>, etceteras are first evaluated for possible transitions.
44. If <StepLoss> is active, then SetPosition, SetPosition2Motors, SetPosParam and GotoSecurePosition commands **are not** ignored. <StepLoss> can only be cleared by a GetStatus or GetFullStatus command.

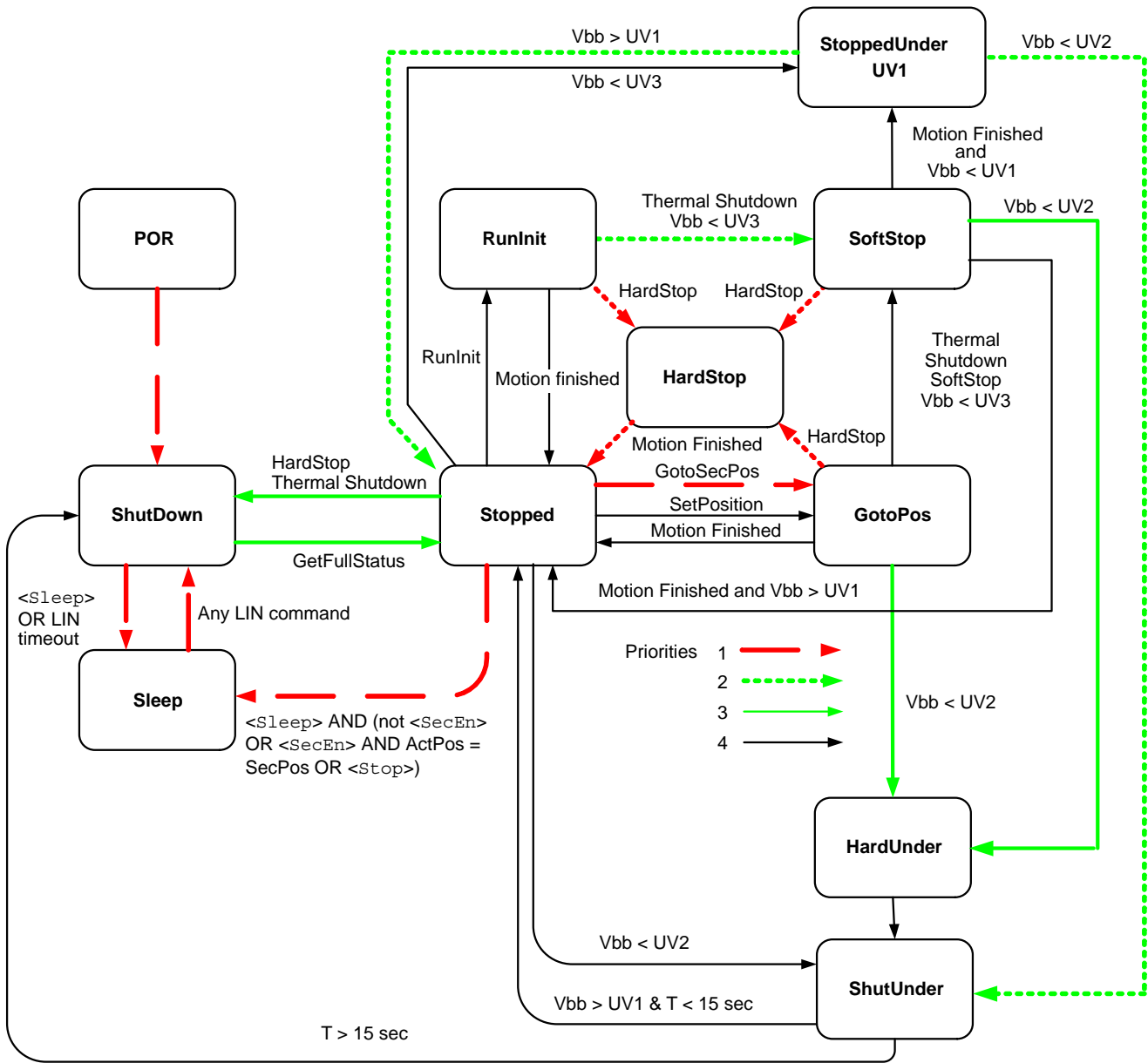

Figure 15. Simplified State Diagram

Remark: IF <SleepEn> = 0, then the arrow from stopped state to sleep state does not exist.

Motordriver

Current Waveforms in the Coils

Figure 16 below illustrates the current fed to the motor coils by the motor driver in half-step mode.

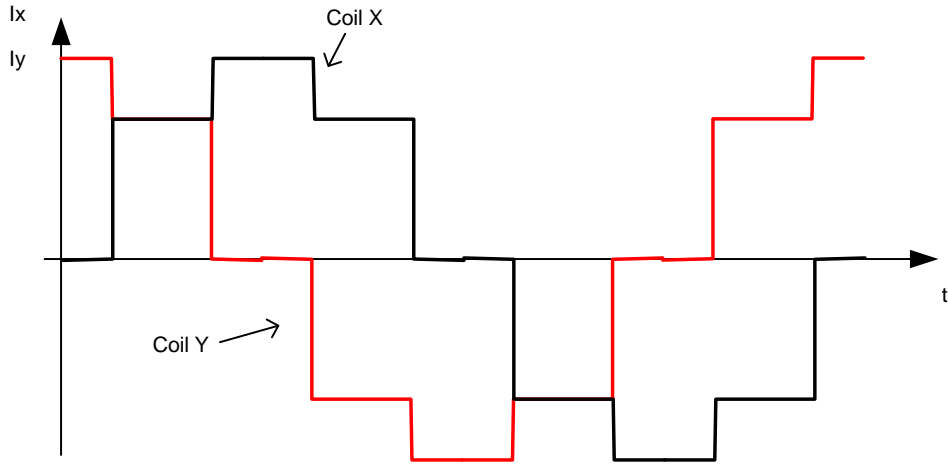

Figure 16. Current Waveforms in Motor Coils X and Y in Halfstep Mode

Whereas Figure 17 below shows the current fed to the coils in 1/16th micro stepping (1 electrical period).

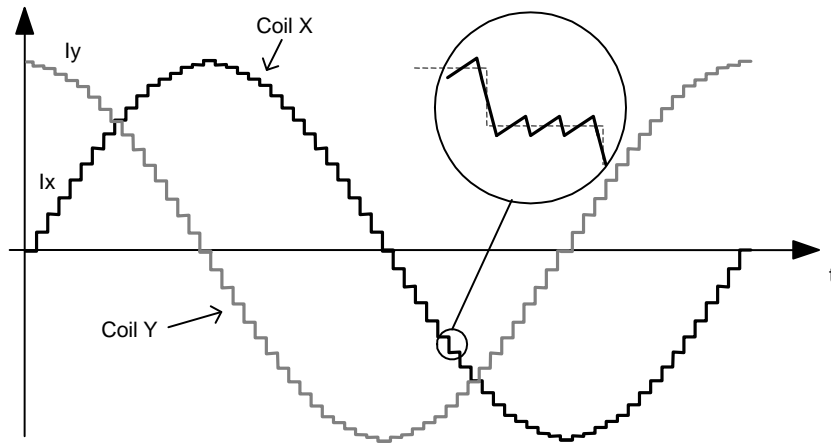

Figure 17. Current Waveforms in Motor Coils X and Y in 1/16th Micro-Step Mode

Motor Current Boost Function

Under certain conditions it can happen that the normal motor currents are not sufficiently high enough to achieve the proper torque for bursting out the motor axis (Especially under cold conditions). For this reason the NCV70628 can be forced to boost mode by setting the <I_BOOST_ENB> bit to ‘0’ via the SetMotorParam command. The boost function increases the current as described in the Irun and Ihold tables. It can only be activated if the junction temperature is lower than t_{low} . When the temperature rises above t_{tw} , the <I_BOOST_ENB> bit is automatically set back to ‘1’ causing that the current is switched back to the normal current set point values.

PWM Regulation

In order to force a given current (determined by <Irun> or <Ihold> and the current position of the rotor) through

the motor coil while ensuring high energy transfer efficiency, a regulation based on PWM principle is used. The regulation loop performs a comparison of the sensed output current to an internal reference, and features a digital regulation generating the PWM signal that drives the output switches. The zoom over one micro-step in the Figure 17 above shows how the PWM circuit performs this regulation. To reduce the current ripple, a higher PWM frequency is selectable. The RAM register PWMfreq is used for this.

Table 24. PWM FREQUENCY SELECTION

PWMfreq	Applied PWM Frequency
0	22,8 kHz
1	45,6 kHz

PWM Jitter

To lower the power spectrum for the fundamental and higher harmonics of the PWM frequency, jitter can be added to the PWM clock. The RAM register <PWMJEN> is used for this.

Table 25. PWM JITTER SELECTION

PWMJEN	Status
0	Single PWM frequency
1	Added jitter to PWM frequency

Motor Starting Phase

At motion start, the currents in the coils are directly switched from <Ihold> to <Irun> with a new

sine/cosine ratio corresponding to the first half (or micro-) step of the motion.

Motor Stopping Phase

At the end of the deceleration phase, the currents are maintained in the coils at their actual DC level (hence keeping the sine/cosine ratio between coils) during the stabilization time t_{stab} (see [AC Table](#)). The currents are then set to the hold values, respectively $I_{hold} \times \sin(TagPos)$ and $I_{hold} \times \cos(TagPos)$, as illustrated below. A new positioning order can then be executed. The stabilization time t_{stab} is programmable via a LIN command. There are 8 values possible that can be set dependant the requirement of the motor application.

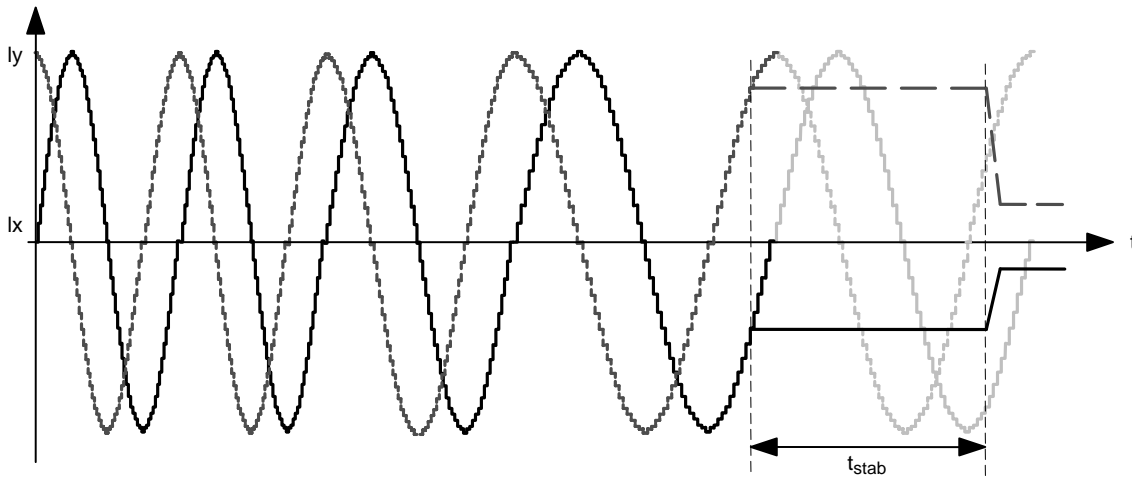

Figure 18. Motor Stopping Phase

Electrical Defect on Coils, Detection and Confirmation

The principle relies on the detection of a voltage drop on at least one transistor of the H-bridge. Then the decision is taken to open the transistors of the defective bridge.

This allows the detection the following short circuits:

- External coil short circuit
- Short between one terminal of the coil and Vbat or Gnd

One cannot detect an internal short in the motor.

Open circuits are detected by 100% PWM duty cycle value during one electrical period with duration, determined by Vmin.

The open coil detection works only in hold current mode (no motor run). More precisely the 100% duty cycle must be present for duration longer than 1/Vmin.

Table 26. ELECTRICAL DEFECT DETECTION

Pins	Fault Mode
Yi or Xi	Short-circuit to GND
Yi or Xi	Short-circuit to Vbat
Yi or Xi	Open
Y1 and Y2	Short circuited
X1 and X2	Short circuited
Xi and Yi	Short circuited

Motor Shutdown Mode

A motor shutdown occurs when:

- The chip temperature rises above the thermal shutdown threshold Ttsd (see [Thermal Shutdown Mode](#)).
- The battery voltage goes below UV2 for longer than 15 seconds (see [Under-Voltage Condition and Autarkic Functionality](#)).
- Flag <ElDef> = '1', meaning an electrical problem is detected on one or both coils, e.g. a short circuit.

A motor shutdown leads to the following:

- H-bridges in high impedance mode.
- The <TagPos> register is loaded with the <ActPos>, except in autarkic states.
- The LIN interface remains active, being able to receive orders or send status.

The conditions to get out of a motor shutdown mode are:

- Reception of a [GetStatus](#) or [GetFullStatus](#) command [AND](#)
- The four above causes are no longer detected

This leads to H-bridges going in Ihold mode. Hence, the circuit is ready to execute any positioning command.

This can be illustrated in the following sequence given as an application example. The master can check whether there is a problem or not and decide which application strategy to adopt.

Table 27. EXAMPLE OF POSSIBLE SEQUENCE USED TO DETECT AND DETERMINE CAUSE OF MOTOR SHUTDOWN

$T_j \geq T_{tsd}$ or $V_{BB} \leq UV2$ ($>15s$) or $\langle ElDef \rangle = '1'$ ↓	SetPosition frame ↓	GetFullStatus or Get-Status frame ↓	GetFullStatus or Get-Status frame ↓...
<ul style="list-style-type: none"> - The circuit is driven in motor shutdown mode - The application is <u>not</u> aware of this 	<ul style="list-style-type: none"> - The position set-point is updated by the LIN Master - Motor shutdown mode \Rightarrow no motion - The application is still unaware 	<ul style="list-style-type: none"> - The application is aware of a problem 	<ul style="list-style-type: none"> - Possible confirmation of the problem
		<ul style="list-style-type: none"> - Reset $\langle TSD \rangle$ or $\langle UV2 \rangle$ or $\langle StepLoss \rangle$ or $\langle ElDef \rangle$ by the application - Possible new detection of over temperature or low voltage or electrical problem \Rightarrow Circuit sets $\langle TW \rangle$ or $\langle TSD \rangle$ or $\langle UV2 \rangle$ or $\langle StepLoss \rangle$ or $\langle ElDef \rangle$ again at '1' 	

Important: While in shutdown mode, since there is no hold current in the coils, the mechanical load can cause a step loss, which indeed cannot be flagged by the NCV70628.

If the LIN communication is lost while in shutdown mode, the circuit enters the sleep mode immediately.

Note: The Priority Encoder is describing the management of states and commands.

Warning: The application should limit the number of consecutive GetStatus or GetFullStatus commands to try to get the NCV70628 out of shutdown mode when this proves to be unsuccessful, e.g. there is a permanent defect. The reliability of the circuit could be altered since Get(Full)Status attempts to disable the protection of the H-bridges.

Motion Detection

Motion detection is based on the back emf generated internally in the running motor. When the motor is blocked, e.g. when it hits the end-stop, the velocity and as a result also the generated back emf, is disturbed. The NCV70628 senses the back emf, applies moving average filter and compares the value with an absolute threshold (AbsThr[3:0]). Instructions for correct use of this level in combination with three additional parameters (MinSamples, FS2StallEn and DC100StEn) are available in a dedicated Application Note “Robust Motion Control with AMIS-3062x Stepper Motor Drivers”.

When the motor is blocked and the velocity is zero after the acceleration phase, the back emf is low or zero. When this value is below the Absolute threshold, Stall is set.

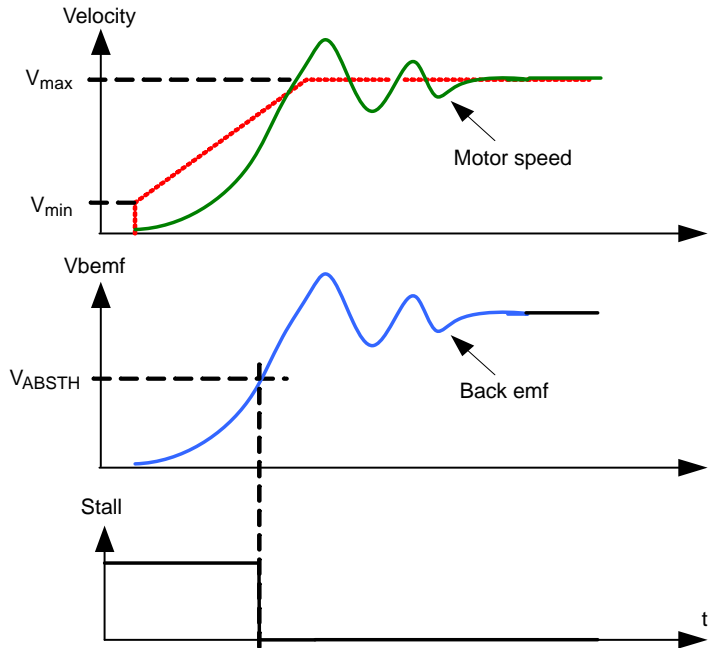

Figure 19. Triggers of the Stall Flag as a function of the measured backemf

By design, the motion will only be detected when the motor is running at the maximum velocity, not during the acceleration or deceleration.

If the motor is positioning when Stall is detected, an (internal) HardStop of the motor is generated and the

<StepLoss> and <Stall> flags are set. These flags can only be reset by sending a GetFullStatus command.

If Stall appears during DualPosition then the first phase is cancelled (via internal hardstop) and after timeout Tstab (see AC table) the second phase at Vmin starts.

When the <Stall> flag is set, the position controller will generate an internal HardStop. As a consequence also the <StepLoss> flag will be set. The position in the internal counter will be copied to the <ActPos> register. All flags can be read out with the GetStatus or GetFullStatus command.

**Important Remark
(limited to motion detection flags / parameters):**

Using GetFullStatus will read **AND** clear the following flags: <StepLoss>, <Stall> and <AbsStall>. New positioning is possible and the <ActPos> register will be further updated.

Using GetStatus will read **AND** clear **ONLY** the <StepLoss> flag. The <Stall> and <AbsStall> flags are **NOT** cleared. New positioning is possible and the <ActPos> register will be further updated.

Motion detection is disabled when the RAM registers <AbsThr[3:0]> is zero. The level can be programmed using the LIN command SetStallParam in the register <AbsThr[3:0]>. Also the OTP register <AbsThr[3:0]> can be set using the LIN command SetOTPParam. These values are copied in the RAM registers during power on reset.

Table 28. ABSOLUTE THRESHOLD SETTINGS

AbsThr Index	AbsThr Level (V) (*)
0	Disabled
1	0.64
2	1.28
3	1.92
4	2.56
5	3.19
6	3.83
7	4.47
8	5.11
9	5.75
A	6.38
B	7.03
C	7.67
D	8.30
E	8.94
F	9.58

NOTE: (*) Not tested in production. Values are typical levels with spread of 0,48V.

MinSamples

<MinSamples[3:0]> is a programmable delay timer. After the zero crossing is detected, the delay counter is started. After the delay time-out (t_{delay}) the back-emf sample is taken. For more information please refer to the Application

Note “Robust Motion Control with AMIS–3062x Stepper Motor Drivers”.

Table 29. BACK EMF SAMPLE DELAY TIME

Index	MinSamples[2:0]	t _{DELAY} (µs)
0	0000	88
1	0001	132
2	0010	175
3	0011	219
4	0100	307
5	0101	395
6	0110	482
7	0111	570
8	1000	658
9	1001	746
A	1010	833
B	1011	921
C	1100	1009
D	1101	1097
E	1110	1184
F	1111	1272

FS2StallEn

If <AbsThr> <> 0 (i.e. motion detection is enabled), then stall detection will be activated AFTER the acceleration ramp + an additional number of full-steps, according to the following table:

Table 30. ACTIVATION DELAY OF MOTION DETECTION

Index	FS2StallEn[2:0]	Delay (Full Steps)
0	000	0
1	001	1
2	010	2
3	011	3
4	100	4
5	101	5
6	110	6
7	111	7

DC100StEn

When a motor with large bemf is operated at high speed and low supply voltage, then the PWM duty cycle can be as high as 100%. This indicates that the supply is too low to generate the required torque and might also result in erroneously triggering the stall detection. The bit <DC100StEn> enables stall detection when duty cycle is 100%. For more information please refer to the Application Note “Robust Motion Control with AMIS–3062x Stepper Motor Drivers”.

Important remark: It is recommended to perform first positioning command (right after the Power–On Reset of the chip or waking–up from Sleep mode) with stall detection feature disabled. Subsequent positioning command (to detect end–position) then may have the stall detection mode enabled.

Lin Controller

General Description

The LIN (local interconnect network) is a serial communications protocol that efficiently supports the control of mechatronics nodes in distributed automotive applications. The physical interface implemented in the NCV70628 is compliant to the LIN rev. 2.2a specification. It features a slave node, thus allowing for:

- single-master / multiple-slave communication
- self synchronization without quartz or ceramics resonator in the slave nodes
- guaranteed latency times for signal transmission
- single-signal-wire communication
- automatic transmission speed detection (between 1 and 19.2 kbit/s)
- configuration flexibility
- data and protected identifier checksum (classic checksum for LIN diagnostic and configuration frames, enhanced checksum for other frames) security and error detection
- detection of defective nodes in the network

It includes the analog physical layer and the digital protocol handler.

The analog circuitry implements a low side driver with a pull-up resistor as a transmitter, and a resistive divider with a comparator as a receiver. The specification of the line driver/receiver follows the ISO 9141 standard with some enhancements regarding the EMI behavior.

Slave Operational Range for Proper Self Synchronization

The LIN interface will synchronize properly in the following conditions:

- Vbat ≥ 8 V
- LIN communication is disabled when Vbat < UV2
- Ground shift between master node and slave node < ±1 V

It is highly recommended to use the same type of reverse battery voltage protection diode for the Master and the Slave nodes.

Functional Description

Analog Part

The transmitter is a low-side driver with a pull-up resistor and slope control. The receiver mainly consists of a comparator with a threshold equal to $V_{BB}/2$. Figure 4 shows the characteristics of the transmitted and received signal. See [AC Parameters](#) for timing values.

Bit Sample Timing

The LIN uses a clock whose frequency is $16 \cdot (1/t_{bit})$. The byte field is synchronized at the falling edge of the start bit. The byte field synchronization has an accuracy of t_{BFS} .

After the byte field synchronization the data bit itself is sampled within the window between the earliest bit sample time and the latest bit sample time. The majority of the samples define the bit level.

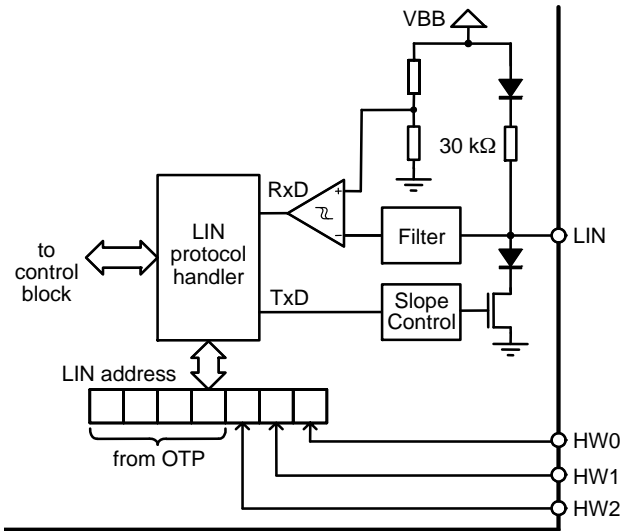

Figure 20. LIN Interface

Table 31. BIT SAMPLE TIMING

Parameter	Comment	Test Condition	Min	Typ	Max	Unit
t_{BFS}	Value of accuracy of the byte field detection	Guaranteed by a digital test			2/16	T_{bit}
t_{EBS}	Earliest bit sample time, $t_{EBS} \leq t_{LBS}$	Guaranteed by a digital test	7/16			T_{bit}
t_{LBS}	Latest bit sample $t_{LBS} \geq t_{EBS}$ $t_{LBS} = 10/16 \cdot T_{bit} - t_{BFS}$	Guaranteed by a digital test				T_{bit}

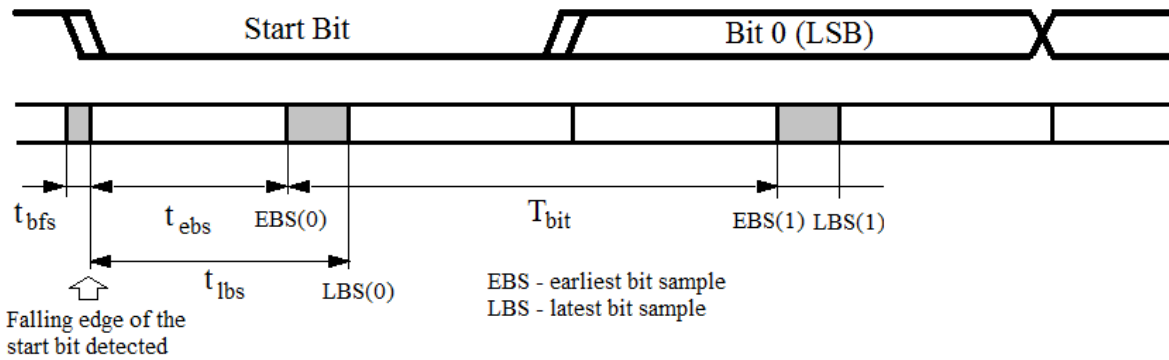

Figure 21. Bit Sample Timing

Protocol Handler

This block implements:

- Bit synchronization
- Bit timing
- The MAC layer
- The LLC layer

- The supervisor

LIN Error Register

The LIN interface implements a register containing an error status of the LIN communication. This register is as follows:

Table 32. LIN ERROR REGISTER

Bit 7	Bit 6	Bit 5	Bit 4	Bit 3	Bit 2	Bit 1	Bit 0
Not used	Not used	Not used	Response error flag (LIN_E)	Time out error flag	Data error Flag	Header error Flag	Bit error Flag

With:

Response error flag (LIN_E): OR function of Data error flag, Bit error flag

Data error flag: Checksum error, data stop bit error or frame length error

Header error flag: PID parity error or PID stop bit error or sync field stop bit error

Time out error flag: Detected dominant pulse duration is greater than maximum allowed header duration (invalid break + sync detected)

Bit error flag: Difference in bit sent and bit monitored on the LIN bus

Time out error flag has only informational purpose. Flags Response error, Data error and Bit error are reset by GetFullStatus and GetActualPos frames. Flags Header error and Time out error are reset by GetFullStatus frame.

Physical Address of the Circuit

The circuit must be provided with a physical address in order to discriminate this circuit from other ones on the LIN bus. This address is coded on 7 bits, yielding the theoretical possibility of 125 different circuits on the same bus due to LIN NAD field restriction (only addresses from 1 to 125 are allowed). If node address 127 is supplied, all slave nodes shall react to the frame (broadcast function). However the maximum number of nodes in a LIN network is also limited by the physical properties of the bus line. It is recommended to limit the number of nodes in a LIN network to not exceed 16. Otherwise the reduced network impedance may prohibit a fault free communication under worst case conditions. Every additional node lowers the network impedance by approximately 3%.

Node address is supplied in 8-bit NAD field within the LIN writing or preparing frames. Lower 7 bits of the NAD field represent the node address, the MSB bit of NAD field shall be always zero since LIN user diagnostic frames are not used on NCV70628. See Table 33 for detailed NAD field description:

Table 33. LIN NAD FIELD

NAD	Description
0	Reserved for go to sleep command
1 – 125	Node address
126	Functional NAD (not used on NCV70628)
127	Broadcast
128 – 255	Free usage (user diagnostics, not used on NCV70628)

The node address is a combination of 4 OTP memory bits and 3 hardwired address bits (pins HW[2:0]). Depending on the Addressing Mode (<ADM> bit in OTP) the bits of the address are combined as illustrated below. OTP bit PA0 is always inverted. Due to restriction in LIN specification rev. 2.2 such combination of hardwired bits and OTP memory bits that would result into node address being 0, 126 or 127 shall be avoided.

Node address is assigned when first break and sync field is detected on LIN bus after power-on-reset. In case of HW2 float state, node address assignment is performed after

HW2 state changes to low or high and next break and sync field is detected on LIN bus. LIN communication is disabled until node address is assigned. Once node address is assigned, it cannot be changed (e.g. via HW[2:0] reconfiguration) until power-on-reset occurs.

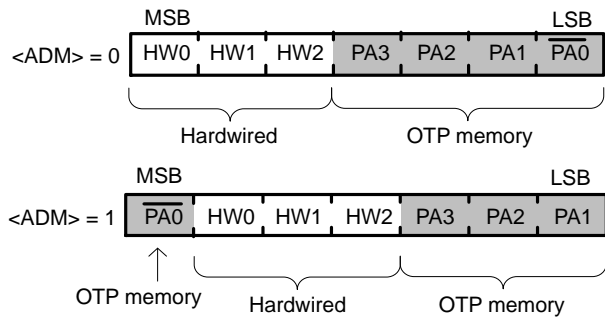

Figure 22. Combination of OTP and Hardwired address bits in function of ADM (Address Mode)

NOTE: Pins HW0 and HW1 are 3.3 V digital inputs, whereas pin HW2 is compliant with a 12 V level, e.g. it can be connected to Vbat or Gnd via a terminal of the PCB.

LIN Frames

LIN frames can be divided into writing and reading frames. A frame is composed of an 8-bit Protected identifier followed by 1 to 8 data-bytes and a checksum byte. The checksum of LIN standard diagnostic and configuration

frames is calculated over only data bytes (so called “classic checksum”). The checksum of other frames is calculated over Protected identifier byte and data bytes (so called “Enhanced checksum”). The checksum is an inverted 8-bit sum with carry.

Writing frames will be used to:

- Program the OTP Memory;
- Configure the component with the stepper-motor parameters (current, speed, stepping-mode, etc.);
- Provide set-point position for the stepper-motor;
- Control the motion state machine.

Whereas reading frames will be used to:

- Get the actual position of the stepper-motor;
- Get status information such as error flags;
- Verify the right programming and configuration of the component.

Writing Frames

The LIN master sends commands and/or information to the slave nodes by means of a writing frame. According to the LIN specification, identifiers are to be used to determine a specific action. If a physical addressing is needed, then first data byte can be dedicated to this, as illustrated in the example below.

Identifier Byte								Data Byte 1							Data Byte 2										
ID0	ID1	ID2	ID3	ID4	ID5	ID6	ID7	NA D0	NA D1	NA D2	NA D3	NA D4	NA D5	NA D6	NA D7										
								node address (NAD field)							command or command parameters										

<ID6> and <ID7> are used for parity check over <ID0> to <ID5>, conform LIN specification. <ID6> = <ID0> ⊗ <ID1> ⊗ <ID2> ⊗ <ID4> (even parity) and <ID7> = NOT(<ID1> ⊗ <ID3> ⊗ <ID4> ⊗ <ID5>) (odd parity).

Reading Frames

A reading frame uses an in-frame response mechanism. That is: the master initiates the frame by sending frame header (synchronization field + protected identifier field), and one slave sends back the data field together with the checksum field. Hence, two types of identifiers can be used for a reading frame:

- Direct ID, which points at a particular slave node, indicating at the same time which kind of information is awaited from this slave node, thus triggering a specific command. This ID provides the fastest access to a read command but is forbidden for any other action since only frame header is sent by master and no other parameters can be passed to the slave node.
- Indirect ID, which only specifies a reading command, the physical address of the slave node that must answer having been passed in a previous writing frame, called a preparing frame. Indirect ID gives more flexibility than a direct one, but provides a slower access to a read command. This sequence of preparing and reading

frame can be used only in case of standard diagnostic and configurations frames (protected identifiers 0x3C and 0x7D).

1. A reading frame with indirect ID must always be consecutive to a preparing frame. Otherwise it will not be taken into account.
2. A reading frame with indirect ID will always return the physical address of the answering slave node in order to ensure robustness in the communication (see definition of LIN standard diagnostic and configuration frames supported by NCV70628).

Preparing Frames

A preparing frame is a frame from the master that warns a particular slave node that it will have to answer in the next frame (being a reading frame). A preparing frame is needed when a reading frame does not use a dynamically assigned direct ID. Preparing and reading frames must be consecutive. A preparing frame will contain the physical address of the LIN slave node that shall answer in the

reading frame and will also contain a command indicating which kind of information is awaited from the slave (see definition of LIN standard diagnostic and configuration frames supported by NCV70628).

Dynamic Assignment of Identifiers

The protected identifier field in the LIN datagram denotes the content of the message. Six identifier bits PID[5:0] and two parity bits PID[7:6] are used to represent the content. Identifiers 0x3C and 0x3D are reserved for LIN diagnostic and configuration frames. Identifiers 0x3E and 0x3F are reserved for future LIN extensions. Slave nodes need to be

very flexible to adapt itself to a given LIN network in order to avoid conflicts with slave nodes from different manufacturers. Standard LIN configuration frame Assign frame ID range issued by the LIN master will write dynamic identifiers into the RAM. Structure of Assign frame ID range LIN frame is described in Table 34. One writing frame is able to assign up to 4 identifiers; therefore 3 frames are needed to assign all 11 NCV70628 identifiers. It is not mandatory to assign all identifiers, only those that are needed by actual application can be assigned. See also description of color code used in the definition of LIN frames in Table 40.

Table 34. DYNAMIC IDENTIFIERS WRITING FRAME (Assign frame ID range)

Byte	Content	Structure							
		Bit 7	Bit 6	Bit 5	Bit 4	Bit 3	Bit 2	Bit 1	Bit 0
0	PID	0x3C							
1	NAD	NAD[7:0] (0x7F for broadcast)							
2	PCI	0x06							
3	SID	0xB7 (Assign PID range)							
4	Data 1	start index							
5	Data 2	PID(start index)							
6	Data 3	PID(start index + 1)							
7	Data 4	PID(start index + 2)							
8	Data 5	PID(start index + 3)							
9	Checksum	Classic Checksum							

Where:

start index: Initial index of PID that shall be assigned, e.g. when start index = 0 then byte Data 2 contains PID(0) code, Data 3 byte contains PID(1) code, Data 4 byte contains PID(2) code and Data 5 byte contains PID(3) code.

PID(index): Complete 8 bits of protected identifier code (including parity bits) that shall be assigned. If PID code is 0 then the corresponding PID will get unassigned. If PID code is 255 then the corresponding PID will remain unchanged.

Complete 8 bits of protected identifier code (including parity bits) shall be supplied. The slave node shall not verify the parity of assigned PID code i.e. it will accept also PID code with incorrect parity. However, in case such PID code is supplied, slave node will not react to LIN frames with this PID code due to incorrect parity. In case PID code 0 is supplied the corresponding PID will be unassigned (slave node will not react to such PID in the future). In case PID

code 255 is supplied the corresponding PID will remain unchanged (don't care value). PID code 255 is required for protected identifier indexes that do not exist in the slave node (indexes 11 and higher in case of NCV70628). Besides these two special PID codes, only PID[5:0] values from 0 to 59 shall be supplied not to interfere with diagnostic and reserved frames identifiers.

Verification of PID assignment shall be performed by issuing reading frame after each Assign frame ID range writing frame. In case NCV70628 can process all requests for PID code assignment within the writing frame, it will respond with Assign frame ID range – positive response frame (see Table 35). Otherwise no response is issued.

NCV70628

Table 35. ASSIGN FRAME ID RANGE – POSITIVE RESPONSE

Byte	Content	Structure							
		Bit 7	Bit 6	Bit 5	Bit 4	Bit 3	Bit 2	Bit 1	Bit 0
0	PID	0x7D							
1	NAD	NAD[7:0]							
2	PCI	0x01							
3	RSID	0xF7							
4	Data 1	0xFF							
5	Data 2	0xFF							
6	Data 3	0xFF							
7	Data 4	0xFF							
8	Data 5	0xFF							
9	Checksum	Classic Checksum							

After each power-up of NCV70628 all PIDs are unassigned therefore PID assignment shall be performed to allow communication using NCV70628 commands. The summary of supported LIN commands and initial PID assignment can be found in Table 36.

Table 36. NCV70628 LIN COMMANDS WITH CORRESPONDING PID INDEX

Command	PID Code Index	PID Assignable	PID After Power-up
<u>SetDualPosition</u>	PID(0)	Yes	Unassigned
<u>SetMotorParam</u>	PID(0)	Yes	Unassigned
<u>SetOtpParam</u>	PID(0)	Yes	Unassigned
<u>SetStallParam</u>	PID(0)	Yes	Unassigned
<u>SetPosParam</u>	PID(0)	Yes	Unassigned
<u>GotoSecurePosition</u>	PID(1)	Yes	Unassigned
<u>GotoSecurePosition</u>	PID(2)	Yes	Unassigned
<u>HardStop</u>	PID(1)	Yes	Unassigned
<u>HardStop</u>	PID(2)	Yes	Unassigned
<u>ResetPosition</u>	PID(1)	Yes	Unassigned
<u>ResetPosition</u>	PID(2)	Yes	Unassigned
<u>SoftStop</u>	PID(1)	Yes	Unassigned
<u>SoftStop</u>	PID(2)	Yes	Unassigned
<u>SetPosition</u>	PID(3)	Yes	Unassigned
<u>SetPosition</u>	PID(4)	Yes	Unassigned
<u>SetPosition2Motors</u>	PID(5)	Yes	Unassigned
<u>GetActualPos</u>	PID(6)	Yes	Unassigned
<u>GetFullStatus</u>	PID(7)	Yes	Unassigned
<u>GetOtpParam</u>	PID(8)	Yes	Unassigned
<u>GetStatus</u>	PID(9)	Yes	Unassigned
<u>GetBemf</u>	PID(10)	Yes	Unassigned
<u>Assign frame ID range</u>	n/a	No	0x3C
<u>Go to sleep</u>	n/a	No	0x3C
<u>Read by identifier ID_0</u>	n/a	No	0x3C

LIN Lost Behavior

Introduction

When the LIN communication is inactive (stable recessive or dominant value) for duration of 4.46 s NCV70628 sets an internal flag called “LIN lost”. The functional behavior depends on the state of OTP bits <SleepEn> and <FailSafe>, and if this loss in LIN communication occurred at (or before) power on reset or in normal powered operation.

Sleep Enable

The OTP bit <SleepEn> enables or disables the entering to low-power sleep mode in case of LIN time-out. By default the entering to sleep-mode is disabled.

Table 37. SLEEP ENABLE SELECTION

<SleepEn>	Behavior
0	Entering low-power sleep mode is disabled except from <Standby> and <Shutdown>
1	Entering low-power sleep mode enabled

Fail Safe Motion

The OTP bit <FailSafe> enables or disables an automatic motion to a predefined secure position. See also Autonomous Motion.

Table 38. FAIL SAFE ENABLE SELECTION

<FailSafe>	Behavior
0	No reference motion in case of LIN – lost
1	Enables reference motion to a secure position in case of LIN–lost (if the device has not been yet referenced with SetDualPosition command)

NCV70628 is able to perform an autonomous secure positioning motion to a preferred position. This positioning starts after the detection of lost LIN communication and depends on OTP bit <FailSafe> RAM register <SecPos [10:0]>. The functional behavior depends on whether LIN communication is lost during start up (see Figure 2) or during normal operation (see Figure 3).

LIN Lost During Start Up

If LIN communication is lost during power up, the <ActPos> register does not reflect the “real” actual position. So at LIN – lost a referencing is started using Dual Positioning. A first negative motion for half the positioner range is initiated until the stall position is reached. The motion parameters stored in OTP will be used for this. After this mechanical end position is reached, <ActPos> will be reset to zero. A second motion of 10 Fullsteps is executed to assure that the motion is really at the end position. The direction of the motion is given by the Shaft bit. Another motion will then start to the Secure Position also stored in OTP.

If LIN is lost during power up, following sequence will be performed:

1. If LIN communication is lost due to LIN timeout NCV70628 will enter <Sleep> mode.
2. If LIN communication is lost (due to HW2 pin floating) AND <FailSafe> = 1 a referencing is started using Dual Positioning and then secure positioning will be performed unless disabled (<SecPos [10:0]> = 0x400).
3. Otherwise no motion is performed.
4. Then NCV70628 will enter <Stop> state.

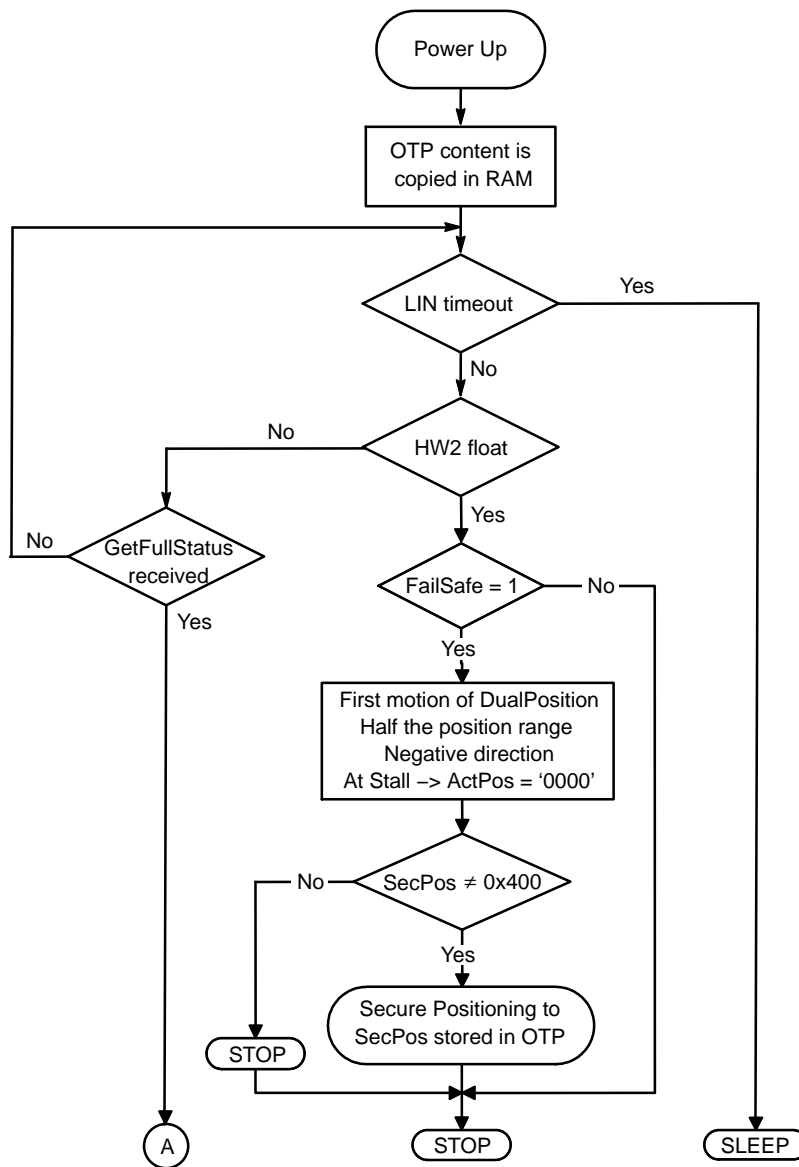

Figure 23. LIN Lost during Start-Up

LIN Lost During Normal Operation

If the LIN communication is lost during normal operation and NCV70628 is referenced (by SetDualPosition or ResetPosition) the <ActPos> register contains the “real” actual position. At LIN – lost an absolute positioning to the stored secure position <SecPos> is done (Secure Positioning).

If the device was not referenced yet, the <ActPos> register does not contain a valid position. At LIN – lost a referencing is started using Dual Positioning in case OTP bit <FailSafe> = 1. A first negative motion of half the positioner range is initiated until the stall position is reached. The motion parameters stored in RAM registers will be used for this. After this mechanical end–position is reached, <ActPos> will be reset to zero. A second motion of 10 Fullsteps is executed to assure that the motion is really at the end position. After the second motion, a third motion is executed to the Secure Position stored in RAM register.

Following sequence will be performed:

5. If LIN communication is lost, NCV70628 was not referenced yet and <FailSafe> = 1 a referencing is started using Dual Positioning. If device was already referenced or <FailSafe> = 0 no referencing motion is performed.
6. If <SecPos[10:0]> ≠ 0x400 a Secure Positioning motion is executed and <SecPos[10:0]> will be copied in <TagPos>. <SecPos[10:0]> from RAM register will be used. This can be different from OTP register if earlier LIN master communication has updated this.
7. Otherwise Secure Positioning is not performed.
8. Depending on <SleepEn> NCV70628 will enter the <Stopped> state or the <Sleep> state.

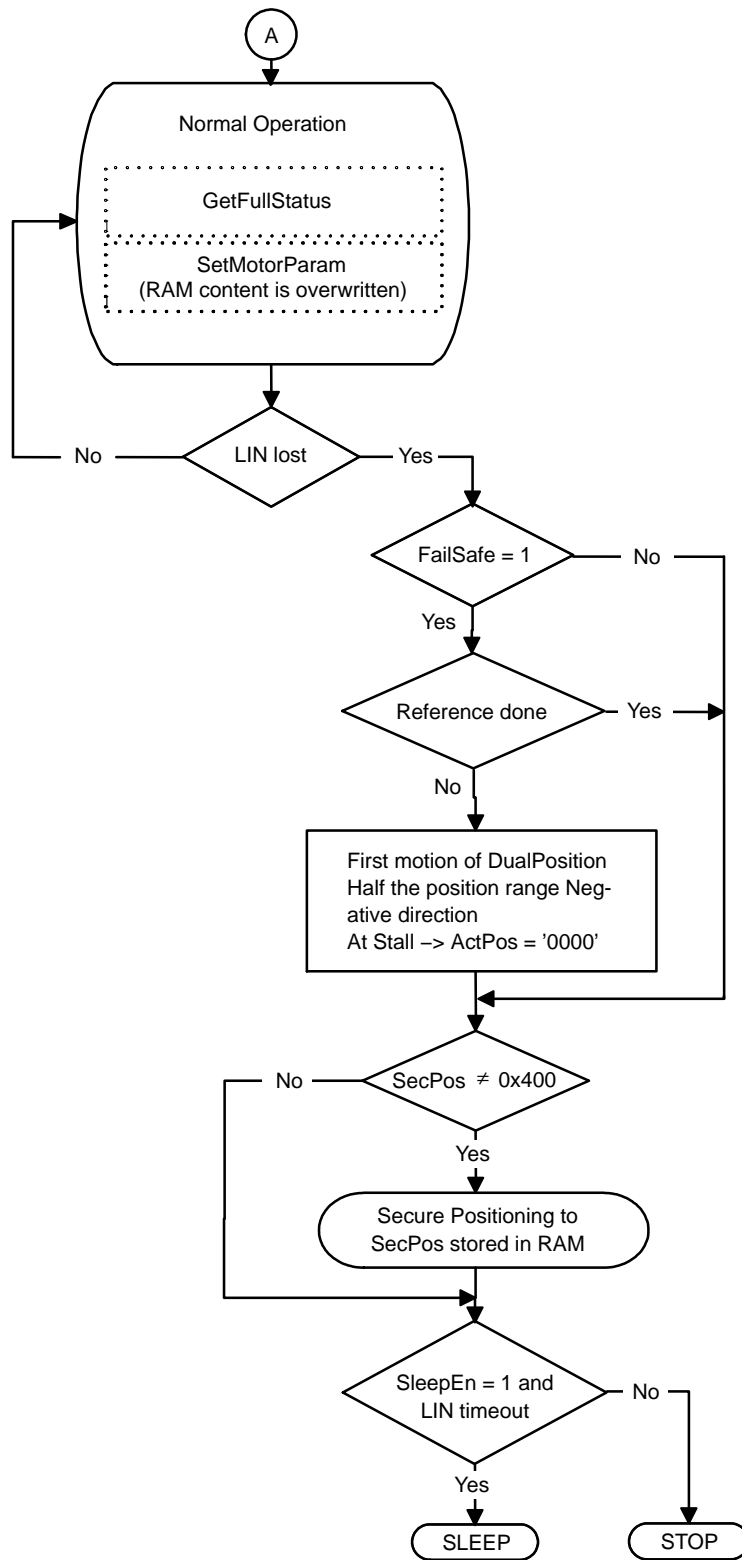

Figure 24. LIN Lost During Normal Operation

Important Remarks:

1. The Secure Position has a resolution of 11 bit (2Fs resolution on positions).
2. If HW2 pin is floating but there is LIN communication, Sleep mode is not entered.

LIN Application Commands

Introduction

The LIN Master will have to use commands to manage the different application tasks the NCV70628 can feature. The commands summary is given in Table 39. below.

Table 39. LIN COMMANDS SUMMARY

Command		Frame PID			Description
Mnemonic	Code	Prep.	Read	Write	
READING COMMAND					
<u>Read by identifier ID 0</u>		0x3C	0x7D		Returns device identification (LIN Supplier ID, Function ID)
<u>GetActualPos</u>			PID(6)		Returns the actual position of the motor
<u>GetFullStatus</u>			PID(7)		Returns a complete status of the circuit
<u>GetOtpParam</u>			PID(8)		Returns the OTP memory content
<u>GetStatus</u>			PID(9)		Returns a short status of the circuit
<u>GetBemf</u>			PID(10)		Returns last back EMF measurement result
WRITING COMMANDS					
<u>Assign frame ID range</u>			0x7D	0x3C	Assigns or disables frame identifiers (PIDs)
<u>GotoSecurePosition</u>	0x04			PID(1) PID(2)	Drives the motor to its secure position
<u>HardStop</u>	0x05			PID(1) PID(2)	Immediate motor stop
<u>ResetPosition</u>	0x06			PID(1) PID(2)	Actual position becomes the zero position
<u>SetDualPosition</u>	0x08			PID(0)	Drives the motor to 2 different positions with different speeds
<u>SetMotorParam</u>	0x09			PID(0)	Programs the motion parameters and values for the current in the motor's coils
<u>SetOtpParam</u>	0x10			PID(0)	Programs (and zaps) a selected byte of the OTP memory
<u>SetStallParam</u>	0x16			PID(0)	Programs the motion detection parameters
<u>SetPosition</u>				PID(3) PID(4)	Drives the motor to a given position
<u>SetPosition2Motors</u>				PID(5)	Drives two motors to two given positions
<u>SetPosParam</u>	0x2F			PID(0)	Drives the motor to a given position and programs some of the motion parameters.
SERVICE COMMANDS					
<u>Go to sleep</u>				0x3C	Drives circuit into sleep mode if <SleepEn> = 1 Drives circuit into stopped mode if <SleepEn> = 0
<u>SoftStop</u>	0x0F			PID(1) PID(2)	Motor stopping with a deceleration phase

These commands are described hereafter, with their corresponding LIN frames. Refer to LIN Frames for more details on LIN frames, particularly for what concerns dynamic assignment of identifiers. A color coding is used to distinguish between master and slave parts within the frames and to highlight dynamic identifiers. An example is shown below.

Table 40. COLOR CODE USED IN THE DEFINITION OF LIN FRAMES

Byte	Content	Structure							
		Bit 7	Bit 6	Bit 5	Bit 4	Bit 3	Bit 2	Bit 1	Bit 0
0	PID	PID(9)							
1	Data 1	ESW	StepLoss	EIDef	UV	TSD	TW	Tinfo[1:0]	
2	Checksum	Enhanced Checksum							

The Identifier is part of LIN frame header and it is always sent by LIN master.
 Convention: – The Identifier and Data sent by the master are in gray presented.
 – The Data sent by the slave is in white presented.

NCV70628

The NCV70628 makes use of dynamic identifiers for all writing and reading frames except standard LIN diagnostic and configuration frames (PIDs 0x3C and 0x7D).

Frame length and content is determined by protected identifier (PID). In case some commands make use of the same PID code, the frame contains also CMD byte to distinguish these commands by command code (see Table 39).

Some of the writing frames contain also node address specification in NAD byte. In means that equal identifier codes (PIDs) can be assigned to multiple slave nodes and the NAD field determines the recipient node. This mechanism also allows usage of broadcast NAD (0x7F) which means that all slave nodes that have subscribed the actual PID shall receive the frame and execute given command.

In case of reading frames (except standard LIN diagnostic and configuration frames), all slave nodes shall have unique PIDs assigned. Since only PID code is sent by the master and there is no other way how to distinguish the slave node that shall accept the frame and transmit a response. If there are at least two slave nodes on LIN bus that have equal PID assigned to any of the reading frames, a conflict on LIN bus will occur when master transmits such PID header because all slave nodes will try to respond in the same time.

Structure of Common Command Frames

Some NCV70628 commands have common LIN frame structure. Thus they make use of the same PID and the actual command to be executed is determined by content of CMD data field. Description of structure of such frames follows.

Table 41. STRUCTURE OF PID(0) WRITING FRAME

Byte	Content	Structure							
		Bit 7	Bit 6	Bit 5	Bit 4	Bit 3	Bit 2	Bit 1	Bit 0
0	PID	PID(0)							
1	NAD	NAD[7:0] (0x7F for broadcast)							
2	CMD	Command							
3	Data 1	Data byte (0xFF if unused)							
4	Data 2	Data byte (0xFF if unused)							
5	Data 3	Data byte (0xFF if unused)							
6	Data 4	Data byte (0xFF if unused)							
7	Data 5	Data byte (0xFF if unused)							
8	Checksum	Enhanced Checksum							

Where:

NAD: Node address field determines receiver node. Broadcast NAD can be used.

Command: Can be 0x08 for SetDualPosition, 0x09 for SetMotorParam, 0x10 for SetOtpParam, 0x16 for SetStallParam or 0x2F for SetPosParam.

Data bytes: Different commands make use of different number of data bytes based on command parameters. If certain data byte is not used, it shall contain value 0xFF according to LIN specification.

Table 42. STRUCTURE OF PID(1) WRITING FRAME

Byte	Content	Structure							
		Bit 7	Bit 6	Bit 5	Bit 4	Bit 3	Bit 2	Bit 1	Bit 0
0	PID	PID(1)							
1	NAD	NAD[7:0] (0x7F for broadcast)							
2	CMD	Command							
3	Checksum	Enhanced Checksum							

Where:

NAD: Node address field determines receiver node. Broadcast NAD can be used.

Command: Can be 0x04 for GotoSecurePosition, 0x05 for HardStop, 0x06 for ResetPosition or 0x0F for SoftStop.

NCV70628

Table 43. STRUCTURE OF PID(2) WRITING FRAME

Byte	Content	Structure							
		Bit 7	Bit 6	Bit 5	Bit 4	Bit 3	Bit 2	Bit 1	Bit 0
0	PID	PID(2)							
1	CMD	Command							
2	Checksum	Enhanced Checksum							

Where:

Command: Can be 0x04 for GotoSecurePosition, 0x05 for HardStop, 0x06 for ResetPosition or 0x0F for SoftStop.

Application Commands

Read by identifier ID 0

Read by identifier is a standard LIN frame used for slave node identification. Response to this command varies based on supplied Identifier field (ID, Byte 4). NCV70628 implements only response to ID 0 which is the minimum required by LIN specification.

Read by identifier ID 0 provides the ability to read slave node Supplier ID, Function ID and Variant while knowing slave node address. This can be achieved by supplying node address in NAD field and using a wildcard value for Supplier ID and Function ID bytes. Slave node with specified node address shall then transmit the response to consecutive reading frame.

Table 44. READ BY IDENTIFIER ID 0 PREPARING FRAME

Byte	Content	Structure							
		Bit 7	Bit 6	Bit 5	Bit 4	Bit 3	Bit 2	Bit 1	Bit 0
0	PID	0x3C							
1	NAD	NAD[7:0] (0x7F if broadcast)							
2	PCI	0x06							
3	SID	0xB2 (Read by identifier)							
4	ID	0x0 (LIN product identification)							
5	Data 1	Supplier ID LSB (or wildcard)							
6	Data 2	Supplier ID MSB (or wildcard)							
7	Data 3	Function ID LSB (or wildcard)							
8	Data 4	Function ID MSB (or wildcard)							
9	Checksum	Classic Checksum							

Where:

Supplier ID: ON Semiconductor Supplier ID is 0x0024 or wildcard value 0x7FFF can be supplied.

Function ID: NCV70628 Function ID is 0x1028 or wildcard value 0xFFFF can be supplied.

Table 45. READ BY IDENTIFIER ID 0 READING FRAME

Byte	Content	Structure							
		Bit 7	Bit 6	Bit 5	Bit 4	Bit 3	Bit 2	Bit 1	Bit 0
0	PID	0x7D							
1	NAD	NAD[7:0]							
2	PCI	0x06							
3	RSID	0xF2							
4	Data 1	Supplier ID LSB							
5	Data 2	Supplier ID MSB							
6	Data 3	Function ID LSB							
7	Data 4	Function ID MSB							
8	Data 5	Variant							
9	Checksum	Classic Checksum							

Where:

- NAD: Node address of responding slave.
- Supplier ID: ON Semiconductor Supplier ID (0x0024).
- Function ID: NCV70628 Function ID (0x1028).
- Variant: NCV70628 version (0xE1).

In case Read by identifier frame with unsupported ID (other than 0) is received by NCV70628 it shall respond with Read by identifier negative response to consecutive reading frame.

Table 46. READ BY IDENTIFIER NEGATIVE RESPONSE READING FRAME

Byte	Content	Structure							
		Bit 7	Bit 6	Bit 5	Bit 4	Bit 3	Bit 2	Bit 1	Bit 0
0	PID	0x7D							
1	NAD	NAD[7:0]							
2	PCI	0x03							
3	RSID	0x7F							
4	Data 1	0xB2 (Requested SID)							
5	Data 2	0x12 (Error code)							
6	Data 3	0xFF							
7	Data 4	0xFF							
8	Data 5	0xFF							
9	Checksum	Classic Checksum							

Where:

- NAD: Node address of responding slave.

GetActualPos

This command is provided to the circuit by the LIN master to get the actual position of the stepper-motor. This position (<ActPos[15:0]>) is returned in signed two's complement 16-bit format. One should note that according to the programmed stepping mode, the LSB's of <ActPos[15:0]> may have no meaning and should be assumed to be '0', as prescribed in Position Ranges. GetActualPos also provides a quick status of the circuit

and the stepper-motor, identical to that obtained by command GetStatus (see further).

Note: A GetActualPos command will attempt to reset <LIN_E>, <DataE> and <BitE> flags.

GetActualPos corresponds to the following LIN reading frame.

Table 47. GetActualPos PID(6) READING FRAME

Byte	Content	Structure							
		Bit 7	Bit 6	Bit 5	Bit 4	Bit 3	Bit 2	Bit 1	Bit 0
0	PID	PID(6)							
1	Data 1	ActPos[7:0]							
2	Data 2	ActPos[15:8]							
3	Data 3	ESW	StepLoss	EIDef	UV	TSD	TW	Tinfo[1:0]	
4	Data 4	Motion[2:0]			Stall	LIN_E	UV2	UV3	VddReset
5	Checksum	Enhanced Checksum							

GetFullStatus

This command is provided to the circuit by the LIN master to get a complete status of the circuit and the stepper-motor. Refer to RAM Registers and Flags Table to see the meaning of the parameters sent to the LIN master.

Note: First response to GetFullStatus command will attempt to reset flags <TW>, <TSD>, <UV2>, <UV3>, <UV>, <ElDef>, <StepLoss>, <OVC1>, <OVC2>, <VddReset>, <LIN_E>, <DataE>, <BitE>, <HeadE> and <TimE>. Second response to GetFullStatus command will attempt to reset flags <Stall> and <AbsStall>.

The master sends PID(7) reading frame. GetFullStatus corresponds to 2 successive LIN in-frame responses to PID(7) reading frame. First response frame contains FrmSeq value equal to 0. Second response frame contains FrmSeq value equal to 1.

Note: It is not mandatory for the LIN master to initiate the second in-frame response if the data in the second response frame is not needed by the application.

Note: It is recommended to poll AbsStall bit (instead of Stall bit) in case LIN Master reads GetFullStatus first response followed by GetFullStatus second response.

Table 48. GetFullStatus PID(7) READING FRAME – FIRST RESPONSE

Byte	Content	Structure							
		Bit 7	Bit 6	Bit 5	Bit 4	Bit 3	Bit 2	Bit 1	Bit 0
0	PID	PID(7)							
1	Data 1	FrmSeq	NAD[6:0]						
2	Data 2	Irun[3:0]				Ihold[3:0]			
3	Data 3	Vmax[3:0]				Vmin[3:0]			
4	Data 4	AbsThr[3:0]				Acc[3:0]			
5	Data 5	Tstab[2:0]			StepMode[1:0]		UV3Thr[2:0]		
6	Data 6	AccShape	Shaft	I_BOOST_ENB	PWMFreq	TimeE	HeadE	OVC1	OVC2
7	Data 7	Motion[2:0]			Stall	LIN_E	UV2	UV3	VddReset
8	Data 8	ESW	StepLoss	EIDef	UV	TSD	TW	Tinfo[1:0]	
9	Checksum	Enhanced Checksum							

Where:

FrmSeq: Value is 0 to identify first response frame.

NAD[6:0]: Node address LSBs.

Table 49. GetFullStatus PID(7) READING FRAME – SECOND RESPONSE

Byte	Content	Structure							
		Bit 7	Bit 6	Bit 5	Bit 4	Bit 3	Bit 2	Bit 1	Bit 0
0	PID	PID(7)							
1	Data 1	FrmSeq	NAD[6:0]						
2	Data 2	ActPos[7:0]							
3	Data 3	ActPos[15:8]							
4	Data 4	TagPos[7:0]							
5	Data 5	TagPos[15:8]							
6	Data 6	SecPos[7:0]							
7	Data 7	FS2StallEn[2:0]			DC100StEn	LIN_E	SecPos[10:8]		
8	Data 8	AbsStall	1	PWMJEn	DC100	MinSamples[3:0]			
9	Checksum	Enhanced Checksum							

Where:

FrmSeq: Value is 1 to identify second response frame.

NAD[6:0]: Node address LSBs.

GetOtpParam

This command is provided to the circuit by the LIN master to read the content of an OTP memory of NCV70628.

GetOtpParam corresponds to following LIN reading frame.

Table 50. GetOtpParam PID(8) READING FRAME

Byte	Content	Structure							
		Bit 7	Bit 6	Bit 5	Bit 4	Bit 3	Bit 2	Bit 1	Bit 0
0	PID	PID(8)							
1	Data 1	OTP byte @0x00							
2	Data 2	OTP byte @0x01							
3	Data 3	OTP byte @0x02							
4	Data 4	OTP byte @0x03							
5	Data 5	OTP byte @0x04							
6	Data 6	If SecPosA = 0 OTP byte @0x05, else OTP byte @0x08							
7	Data 7	If SecPosA = 0 OTP byte @0x06, else OTP byte @0x09							
8	Data 8	OTP byte @0x07							
9	Checksum	Enhanced Checksum							

GetStatus

This command is provided to the circuit by the LIN master to get a quick status (compared to that of GetFullStatus command) of the circuit and of the stepper-motor. Refer to Flags Table to see the meaning of the parameters sent to the LIN master.

Note: A GetStatus command will attempt to reset flags <TW>, <TSD>, <UV>, <UV2>, <UV3>, <ElDef> and <StepLoss>.

If there is only an open coil detected the <ElDef> flag will be cleared after the GetStatus command. If <ElDef> is set due to a short on one of the coils, the <ElDef> can only be cleared via a GetFullStatus command.

GetStatus corresponds to following LIN PID(9) frame.

Table 51. GetStatus PID(9) READING FRAME

Byte	Content	Structure							
		Bit 7	Bit 6	Bit 5	Bit 4	Bit 3	Bit 2	Bit 1	Bit 0
0	PID	PID(9)							
1	Data 1	ESW	StepLoss	ElDef	UV	TSD	TW	Tinfo[1:0]	
2	Checksum	Enhanced Checksum							

GetBemf

This command is provided to the circuit by the LIN master to get a result of last back EMF measurement. The Coil bit determines whether the measurement was performed on coil

X (Coil = 0) or Y (Coil = 1). Refer to [Flags Table](#) to see the meaning of the parameters sent to the LIN master.

GetBemf corresponds to following LIN PID(10) frame.

Table 52. GetBemf PID(10) READING FRAME

Byte	Content	Structure							
		Bit 7	Bit 6	Bit 5	Bit 4	Bit 3	Bit 2	Bit 1	Bit 0
0	PID	PID(10)							
1	Data 1	1	BEMF_DC100	Coil	BEMF_OUT[4:0]				
2	Checksum	Enhanced Checksum							

GotoSecurePosition

This command is provided by the LIN master to one, all or a group of the stepper-motors to move to the secure position <SecPos [10:0]>. It can also be internally triggered if the LIN bus communication is lost, after an initialization phase, or prior to going into sleep mode. See the [priority encoder](#) description for more details. The priority encoder table also acknowledges the cases where a GotoSecurePosition command will be ignored. This command is executed regardless of <SecEn> value.

Note: One slave node can be addressed using its node address in NAD field of PID(1) writing frame. All slave nodes can be addressed using broadcast NAD in PID(1) writing frame. A certain group of nodes can be addressed by first assigning equal PID(2) code and then issuing PID(2) writing frame.

GotoSecurePosition corresponds to the following LIN PID(1) and PID(2) writing frames.

Table 53. GotoSecurePosition PID(1) WRITING FRAME

Byte	Content	Structure							
		Bit 7	Bit 6	Bit 5	Bit 4	Bit 3	Bit 2	Bit 1	Bit 0
0	PID	PID(1)							
1	NAD	NAD[7:0] (0x7F for broadcast)							
2	CMD	0x04							
3	Checksum	Enhanced Checksum							

Table 54. GotoSecurePosition PID(2) WRITING FRAME

Byte	Content	Structure							
		Bit 7	Bit 6	Bit 5	Bit 4	Bit 3	Bit 2	Bit 1	Bit 0
0	PID	PID(2)							
1	CMD	0x04							
2	Checksum	Enhanced Checksum							

HardStop

This command will be internally triggered when an electrical problem is detected in one or both coils, leading to shutdown mode. If this occurs while the motor is moving, the <StepLoss> flag is raised to allow warning of the LIN master at the next GetStatus command that steps may have been lost. Once the motor is stopped, <ActPos> register is copied into <TagPos> register to ensure keeping the stop position. A HardStop command can also be issued by the LIN master for some safety reasons.

Note: One slave node can be addressed using its node address in NAD field of PID(1) writing frame. All slave nodes can be addressed using broadcast NAD in PID(1) writing frame. A certain group of nodes can be addressed by first assigning equal PID(2) code and then issuing PID(2) writing frame.

HardStop corresponds to the following LIN PID(1) and PID(2) writing frames.

Table 55. HardStop PID(1) WRITING FRAME

Byte	Content	Structure							
		Bit 7	Bit 6	Bit 5	Bit 4	Bit 3	Bit 2	Bit 1	Bit 0
0	PID	PID(1)							
1	NAD	NAD[7:0] (0x7F for broadcast)							
2	CMD	0x05							
3	Checksum	Enhanced Checksum							

Table 56. HardStop PID(2) WRITING FRAME

Byte	Content	Structure							
		Bit 7	Bit 6	Bit 5	Bit 4	Bit 3	Bit 2	Bit 1	Bit 0
0	PID	PID(2)							
1	CMD	0x05							
2	Checksum	Enhanced Checksum							

ResetPosition

This command is provided to the circuit by the LIN master to reset <ActPos> and <TagPos> registers to zero. This can be helpful to prepare for instance a relative positioning. The reset position command sets the internal flag “Reference done”.

Note: One slave node can be addressed using its node address in NAD field of PID(1) writing frame. All slave nodes can be addressed using broadcast NAD in PID(1) writing frame. A certain group of nodes can be addressed by first assigning equal PID(2) code and then issuing PID(2) writing frame.

ResetPosition corresponds to the following LIN PID(1) and PID(2) writing frames.

Table 57. ResetPosition PID(1) WRITING FRAME

Byte	Content	Structure							
		Bit 7	Bit 6	Bit 5	Bit 4	Bit 3	Bit 2	Bit 1	Bit 0
0	PID	PID(1)							
1	NAD	NAD[7:0] (0x7F for broadcast)							
2	CMD	0x06							
3	Checksum	Enhanced Checksum							

Table 58. ResetPosition PID(2) WRITING FRAME

Byte	Content	Structure							
		Bit 7	Bit 6	Bit 5	Bit 4	Bit 3	Bit 2	Bit 1	Bit 0
0	PID	PID(2)							
1	CMD	0x06							
2	Checksum	Enhanced Checksum							

SetDualPosition

This command is provided to the circuit by the LIN master in order to perform a positioning of the motor using two different velocities. See Dual Positioning. After Dual positioning the internal flag “Reference done” is set.

Note: This sequence cannot be interrupted by another positioning command.

NCV70628

SetDualPosition corresponds to the following LIN PID(0) writing frame.

Table 59. SetDualPosition PID(0) WRITING FRAME

Byte	Content	Structure							
		Bit 7	Bit 6	Bit 5	Bit 4	Bit 3	Bit 2	Bit 1	Bit 0
0	PID	PID(0)							
1	NAD	NAD[7:0] (0x7F for broadcast)							
2	CMD	0x08							
3	Data 1	Vmax[3:0]				Vmin[3:0]			
4	Data 2	Pos1[7:0]							
5	Data 3	Pos1[15:8]							
6	Data 4	Pos2[7:0]							
7	Data 5	Pos2[15:8]							
8	Checksum	Enhanced Checksum							

Where:

Vmax[3:0]: Max velocity for first motion

Vmin[3:0]: Min velocity for first motion and velocity for the second motion

Pos1[15:0]: First position to be reached during the first motion

Pos2[15:0]: Relative position of the second motion

SetMotorParam

This command is provided to the circuit by the LIN master to set the values for the stepper motor parameters (listed below) in RAM. Refer to RAM Registers to see the meaning of the parameters sent by the LIN master.

Important: If a SetMotorParam occurs while a motion is ongoing, it will modify at once the motion parameters (see

Position Controller). Therefore the application should not change other parameters than <Vmax> and <Vmin> while a motion is running, otherwise correct positioning cannot be guaranteed.

SetMotorParam corresponds to the following LIN PID(0) writing frame.

Table 60. SetMotorParam PID(0) WRITING FRAME

Byte	Content	Structure							
		Bit 7	Bit 6	Bit 5	Bit 4	Bit 3	Bit 2	Bit 1	Bit 0
0	PID	PID(0)							
1	NAD	NAD[7:0] (0x7F for broadcast)							
2	CMD	0x09							
3	Data 1	Irun[3:0]				Ihold[3:0]			
4	Data 2	Vmax[3:0]				Vmin[3:0]			
5	Data 3	AccShape	Shaft	I_BOOST_ENB	PWMFreq	Acc[3:0]			
6	Data 4	SecPos[7:0]							
7	Data 5	TStab[2:0]			StepMode[1:0]		SecPos[10:8]		
8	Checksum	Enhanced Checksum							

SetOtpParam

This command is provided to the circuit by the LIN master to program the content of the OTP memory byte on address OTPA[3:0] and to zap it.

Important: This command must be sent under a specific V_{BB} voltage value. See parameter VBBOTP in [DC](#)

Parameters. This is a mandatory condition to ensure reliable zapping.

SetOtpParam corresponds to the following LIN PID(0) writing frame.

Table 61. SetOtpParam PID(0) WRITING FRAME

Byte	Content	Structure							
		Bit 7	Bit 6	Bit 5	Bit 4	Bit 3	Bit 2	Bit 1	Bit 0
0	PID	PID(0)							
1	NAD	NAD[7:0] (0x7F for broadcast)							
2	CMD	0x10							
3	Data 1	1	1	1	1	OTPA[3:0]			
4	Data 2	D[7:0]							
5	Data 3	0xFF							
6	Data 4	0xFF							
7	Data 5	0xFF							
8	Checksum	Enhanced Checksum							

Where:

OTPA[3:0]: Address of OTP memory byte.

D[7:0]: Data to be programmed into OTP memory byte.

SetStallParam

This command sets the motion detection parameters and the related stepper–motor parameters, such as the minimum and maximum velocity, the run and hold current,

acceleration and step mode. See Motion detection for the meaning of the parameters sent by the LIN Master.

SetStallParam corresponds to the following LIN PID(0) writing frame.

Table 62. SetStallParam PID(0) WRITING FRAME

Byte	Content	Structure							
		Bit 7	Bit 6	Bit 5	Bit 4	Bit 3	Bit 2	Bit 1	Bit 0
0	PID	PID(0)							
1	NAD	NAD[7:0] (0x7F for broadcast)							
2	CMD	0x16							
3	Data 1	Irun[3:0]				Ihold[3:0]			
4	Data 2	Vmax[3:0]				Vmin[3:0]			
5	Data 3	AbsThr[3:0]				Acc[3:0]			
6	Data 4	FS2StallEn[2:0]			DC100StEn		MinSamples[3:0]		
7	Data 5	AccShape	Shaft	PWMJEn	StepMode[1:0]		UV3Thr[2:0]		
8	Checksum	Enhanced Checksum							

SetPosition

This command is provided to the circuit by the LIN master to drive one, all or a group of motors to one given absolute position. See [Positioning](#) for more details. The priority encoder table (see [Priority Encoder](#)) describes the cases where a [SetPosition](#) command will be ignored.

Note: One slave node can be addressed using its node address in NAD field of PID(3) writing frame. All slave

nodes can be addressed using broadcast NAD in PID(3) writing frame. A certain group of nodes can be addressed by first assigning equal PID(4) code and then issuing PID(4) writing frame.

SetPosition corresponds to the following PID(3) and PID(4) LIN writing frames.

Table 63. SetPosition PID(3) WRITING FRAME

Byte	Content	Structure							
		Bit 7	Bit 6	Bit 5	Bit 4	Bit 3	Bit 2	Bit 1	Bit 0
0	PID	PID(3)							
1	NAD	NAD[7:0] (0x7F for broadcast)							
2	Data 1	Pos[7:0]							
3	Data 2	Pos[15:8]							
4	Checksum	Enhanced Checksum							

Table 64. SetPosition PID(4) WRITING FRAME

Byte	Content	Structure							
		Bit 7	Bit 6	Bit 5	Bit 4	Bit 3	Bit 2	Bit 1	Bit 0
0	PID	PID(4)							
1	Data 1	Pos[7:0]							
2	Data 2	Pos[15:8]							
3	Checksum	Enhanced Checksum							

SetPosition2Motors

This command is provided to the circuit by the LIN Master to drive two motors to a given absolute position. See Positioning for more details.

The priority encoder table (see Priority Encoder) describes the cases where a SetPosition2Motors command will be ignored.

SetPosition2Motors corresponds to the following PID(5) LIN writing frame.

Table 65. SetPosition2Motors PID(5) WRITING FRAME

Byte	Content	Structure							
		Bit 7	Bit 6	Bit 5	Bit 4	Bit 3	Bit 2	Bit 1	Bit 0
0	PID	PID(5)							
1	Data 1	NAD1[7:0] (broadcast not allowed, broadcast NAD will cause the command will be ignored)							
2	Data 2	Pos1[7:0]							
3	Data 3	Pos1[15:8]							
4	Data 4	NAD2[7:0] (broadcast not allowed, broadcast NAD will cause the command will be ignored)							
5	Data 5	Pos2[7:0]							
6	Data 6	Pos2[15:8]							
7	Checksum	Enhanced Checksum							

Where:

NAD1[7:0]: Node address of the first slave. In case broadcast NAD is used, the slave node will ignore this command though slave node specified by NAD2[7:0] shall perform the command anyway.

NAD2[7:0]: Node address of the second slave. In case broadcast NAD is used, the slave node will ignore this command though slave node specified by NAD1[7:0] shall perform the command anyway.

Pos1[15:0]: Signed 16-bit target position of first motor.

Pos2[15:0]: Signed 16-bit target position of second motor.

SetPosParam

This command is provided to the circuit by the LIN Master to drive one motor to a given absolute position. It also sets some of the values for the stepper motor parameters such as minimum and maximum velocity.

SetPosParam corresponds to the following PID(0) LIN writing frame.

Table 66. SetPosParam PID(0) WRITING FRAME

Byte	Content	Structure							
		Bit 7	Bit 6	Bit 5	Bit 4	Bit 3	Bit 2	Bit 1	Bit 0
0	PID	PID(0)							
1	NAD	NAD[7:0] (0x7F for broadcast)							
2	CMD	0x2F							
3	Data 1	Pos[7:0]							
4	Data 2	Pos[15:8]							
5	Data 3	Vmax[3:0]				Vmin[3:0]			
6	Data 4	AbsThr[3:0]				Acc[3:0]			
7	Data 5	0xFF							
8	Checksum	Enhanced Checksum							

Where:

Pos[15:0]: Signed 16-bit position set-point.

Go to Sleep

This command is provided to the circuit by the LIN master to put all the slave nodes connected to the LIN bus into sleep mode. If this command occurs during a motion of the motor, TagPos is reprogrammed to SecPos (provided SecPos is different from “100 0000 0000”), or a SoftStop is executed before going to sleep mode. See LIN specification rev. 2.2 and Sleep Mode. The corresponding LIN frame is a master request command frame (identifier **0x3C**) with

data byte 1 containing value 0x00 while the following data bytes contain value 0xFF. However, according to LIN specification, slave node shall not verify whether the latter data bytes contain value 0xFF and shall accept the request anyway.

Note: <SleepEn> needs to be set to 1 in order to allow the device to go to sleep. If <SleepEn> is 0 the device will go into “stopped state”.

Table 67. GO TO SLEEP MASTER REQUEST FRAME

Byte	Content	Structure							
		Bit 7	Bit 6	Bit 5	Bit 4	Bit 3	Bit 2	Bit 1	Bit 0
0	PID	0x3C							
1	NAD	0x00 (Go to sleep)							
2	Data 1	0xFF							
3	Data 2	0xFF							
4	Data 3	0xFF							
5	Data 4	0xFF							
6	Data 5	0xFF							
7	Data 6	0xFF							
8	Data 7	0xFF							
9	Checksum	Classic Checksum							

SoftStop

If a SoftStop command occurs during a motion of the stepper motor, it provokes an immediate deceleration to V_{min} (see Minimum Velocity) followed by a stop, regardless of the position reached. Once the motor is stopped, $TagPos$ register is overwritten with value in $ActPos$ register to ensure keeping the stop position.

Command SoftStop occurs in the following cases:

- The chip temperature rises above the thermal shutdown threshold (see DC Parameters and Temperature Management);
- The VBB drops under the UV3 level; (see DC Parameters and Battery Voltage Management);

- The LIN master requests a SoftStop. Hence SoftStop will correspond to the following LIN PID(1) and PID(2) writing frames.

Note: One slave node can be addressed using its node address in NAD field of PID(1) writing frame. All slave nodes can be addressed using broadcast NAD in PID(1) writing frame. A certain group of nodes can be addressed by first assigning equal PID(2) code and then issuing PID(2) writing frame.

Note: A SoftStop command occurring during a Dual Positioning sequence is not taken into account.

Table 68. SoftStop PID(1) WRITING FRAME

Byte	Content	Structure							
		Bit 7	Bit 6	Bit 5	Bit 4	Bit 3	Bit 2	Bit 1	Bit 0
0	PID	PID(1)							
1	NAD	NAD[7:0] (0x7F for broadcast)							
2	CMD	0x0F							
3	Checksum	Enhanced Checksum							

Table 69. SoftStop PID(2) WRITING FRAME

Byte	Content	Structure							
		Bit 7	Bit 6	Bit 5	Bit 4	Bit 3	Bit 2	Bit 1	Bit 0
0	PID	PID(2)							
1	CMD	0x0F							
2	Checksum	Enhanced Checksum							

MECHANICAL CASE OUTLINE

PACKAGE DIMENSIONS

ON Semiconductor®

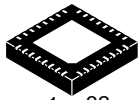

1 32

SCALE 2:1

QFNW32 5x5, 0.5P
CASE 484AB
ISSUE D

DATE 07 SEP 2018

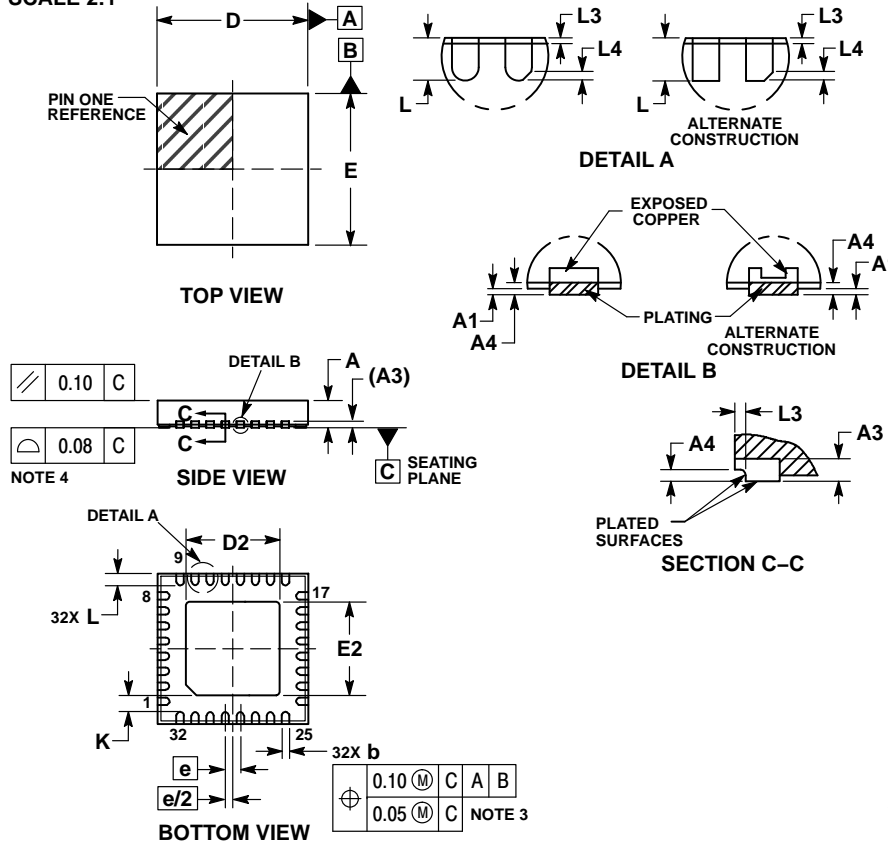

NOTES:

1. DIMENSIONS AND TOLERANCING PER ASME Y14.5M, 1994.
2. CONTROLLING DIMENSION: MILLIMETERS.
3. DIMENSION b APPLIES TO PLATED TERMINAL AND IS MEASURED BETWEEN 0.10 AND 0.20MM FROM THE TERMINAL TIP.
4. COPLANARITY APPLIES TO THE EXPOSED PAD AS WELL AS THE TERMINALS.

MILLIMETERS			
DIM	MIN	NOM	MAX
A	0.80	0.90	1.00
A1	---	---	0.05
A3	0.20 REF		
A4	0.10	---	---
b	0.20	0.25	0.30
D	4.90	5.00	5.10
D2	3.00	3.10	3.20
E	4.90	5.00	5.10
E2	3.00	3.10	3.20
e	0.50 BSC		
K	0.35	---	---
L	0.30	0.40	0.50
L3	---	---	0.10
L4	0.08 REF		

GENERIC MARKING DIAGRAM*

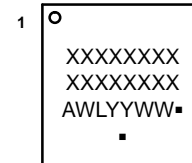

- XXXXX = Specific Device Code
- A = Assembly Location
- WL = Wafer Lot
- YY = Year
- WW = Work Week
- = Pb-Free Package

(Note: Microdot may be in either location)

*This information is generic. Please refer to device data sheet for actual part marking. Pb-Free indicator, "C" or microdot "▪", may or may not be present. Some products may not follow the Generic Marking.

RECOMMENDED SOLDERING FOOTPRINT*

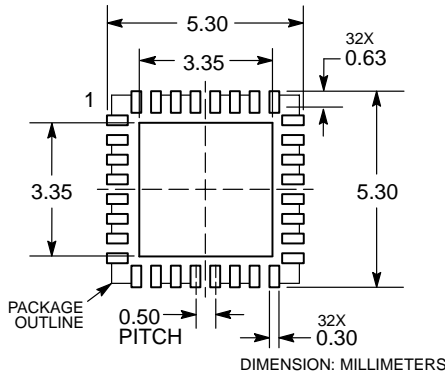

*For additional information on our Pb-Free strategy and soldering details, please download the ON Semiconductor Soldering and Mounting Techniques Reference Manual, SOLDERRM/D.

DOCUMENT NUMBER:	98AON14940G	Electronic versions are uncontrolled except when accessed directly from the Document Repository. Printed versions are uncontrolled except when stamped "CONTROLLED COPY" in red.
DESCRIPTION:	QFNW32 5x5, 0.5P	PAGE 1 OF 1

ON Semiconductor and ON are trademarks of Semiconductor Components Industries, LLC dba ON Semiconductor or its subsidiaries in the United States and/or other countries. ON Semiconductor reserves the right to make changes without further notice to any products herein. ON Semiconductor makes no warranty, representation or guarantee regarding the suitability of its products for any particular purpose, nor does ON Semiconductor assume any liability arising out of the application or use of any product or circuit, and specifically disclaims any and all liability, including without limitation special, consequential or incidental damages. ON Semiconductor does not convey any license under its patent rights nor the rights of others.

onsemi, **Onsemi**, and other names, marks, and brands are registered and/or common law trademarks of Semiconductor Components Industries, LLC dba "**onsemi**" or its affiliates and/or subsidiaries in the United States and/or other countries. **onsemi** owns the rights to a number of patents, trademarks, copyrights, trade secrets, and other intellectual property. A listing of **onsemi**'s product/patent coverage may be accessed at www.onsemi.com/site/pdf/Patent-Marking.pdf. **onsemi** reserves the right to make changes at any time to any products or information herein, without notice. The information herein is provided "as-is" and **onsemi** makes no warranty, representation or guarantee regarding the accuracy of the information, product features, availability, functionality, or suitability of its products for any particular purpose, nor does **onsemi** assume any liability arising out of the application or use of any product or circuit, and specifically disclaims any and all liability, including without limitation special, consequential or incidental damages. Buyer is responsible for its products and applications using **onsemi** products, including compliance with all laws, regulations and safety requirements or standards, regardless of any support or applications information provided by **onsemi**. "Typical" parameters which may be provided in **onsemi** data sheets and/or specifications can and do vary in different applications and actual performance may vary over time. All operating parameters, including "Typicals" must be validated for each customer application by customer's technical experts. **onsemi** does not convey any license under any of its intellectual property rights nor the rights of others. **onsemi** products are not designed, intended, or authorized for use as a critical component in life support systems or any FDA Class 3 medical devices or medical devices with a same or similar classification in a foreign jurisdiction or any devices intended for implantation in the human body. Should Buyer purchase or use **onsemi** products for any such unintended or unauthorized application, Buyer shall indemnify and hold **onsemi** and its officers, employees, subsidiaries, affiliates, and distributors harmless against all claims, costs, damages, and expenses, and reasonable attorney fees arising out of, directly or indirectly, any claim of personal injury or death associated with such unintended or unauthorized use, even if such claim alleges that **onsemi** was negligent regarding the design or manufacture of the part. **onsemi** is an Equal Opportunity/Affirmative Action Employer. This literature is subject to all applicable copyright laws and is not for resale in any manner.

ADDITIONAL INFORMATION

TECHNICAL PUBLICATIONS:

Technical Library: www.onsemi.com/design/resources/technical-documentation
onsemi Website: www.onsemi.com

ONLINE SUPPORT: www.onsemi.com/support

For additional information, please contact your local Sales Representative at www.onsemi.com/support/sales