

3.3V-5V VOLTAGE TRANSLATOR™

Manual

All Mikroelektronika's development systems feature a large number of peripheral modules expanding microcontroller's range of application and making the process of program testing easier. In addition to these modules, it is also possible to use numerous additional modules linked to the development system through the I/O port connectors. Some of these additional modules can operate as stand-alone devices without being connected to the microcontroller.

Additional board

 **MikroElektronika**

SOFTWARE AND HARDWARE SOLUTIONS FOR EMBEDDED WORLD ...making it simple

3.3V-5V VOLTAGE TRANSLATOR

The 3.3V-5V VOLTAGE TRANSLATOR additional board is used to adjust voltage levels of a development system sending voltage signals of 3.3V and a device receiving voltage signals of 5V.

How to connect the board?

The 3.3V-5V VOLTAGE TRANSLATOR board can be easily connected to a development system via a 2x5 connector CN1 and a flat cable with appropriate IDC10 connectors, Figure 1. The board is connected to a device via a 2x5 connector CN2.

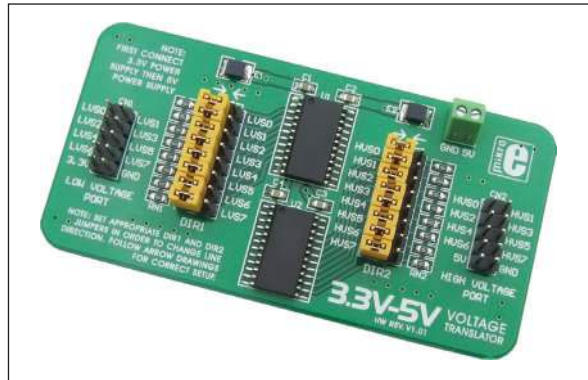

Figure 1: 3.3V-5V VOLTAGE TRANSLATOR board

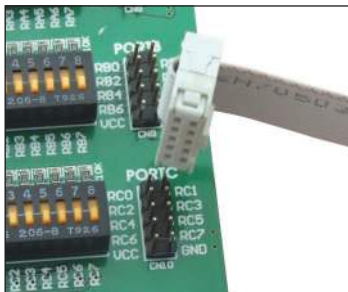

Figure 2: Connecting IDC10 connector to a development system



Figure 3: Flat cable with IDC10 connectors

How to use the board?

The additional board is used to adjust different voltage levels by means of two transceivers 74LVCC3245. The board comes with jumpers placed so as to adjust voltage signals of 3.3V to voltage signals of 5V. If necessary, voltage signal adjustment may also be performed in the opposite direction (from 5V to 3.3V).

The additional board is powered by 3.3V and 5V. The 3.3V power supply voltage is supplied from the development system, whereas the 5V DC power supply voltage is supplied from an external power supply source via the CN3 connector.

The 3.3V-5V VOLTAGE TRANSLATOR board is capable of bidirectional adjustment of voltage signals, which means that voltage signals may be sent and received at the same time (from 3.3V to 5V and vice versa). In bidirectional mode, the position of jumpers depends on the voltage signal direction. For example, if voltage signals are sent from a development system (3.3V) via the LVS0 pin, to a device (5V) via the HVS0 pin, it is necessary to place jumpers J1 and J9 in the position marked →. At the same time, voltage signals may be sent from a device (5V) to a development system (3.3V). In this case, voltage signals are sent from the HVS1 pin to the LVS1 pin, so that jumpers J10 and J2 should be placed in the position marked ←. These rules apply to all jumpers provided on the additional board. When placing jumpers, pay attention to arrows next to jumpers. If arrows are in the opposite directions (↔ ←), voltage signals will not be properly sent/received (from 3.3V to 5V and vice versa).

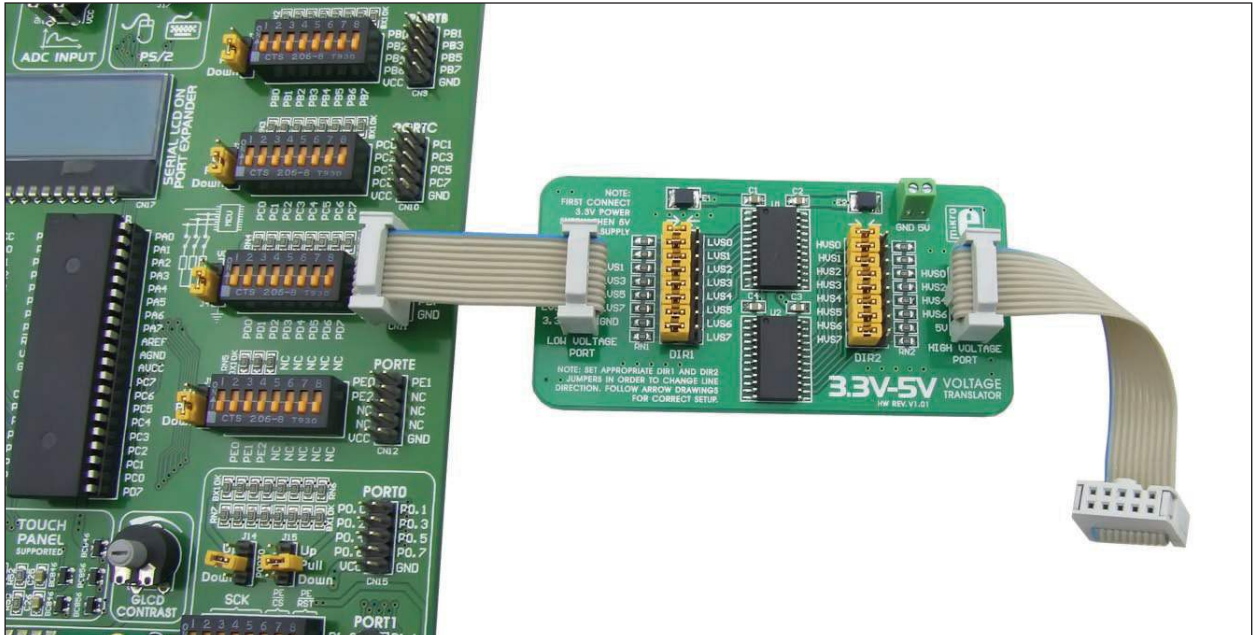

Figure 4: 3.3V-5V VOLTAGE TRANSLATOR board connected to a development system

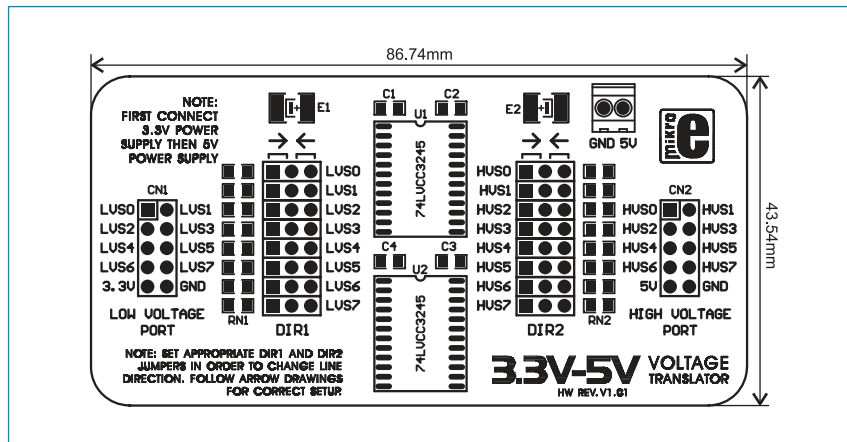

Figure 5: Dimensions of the additional board

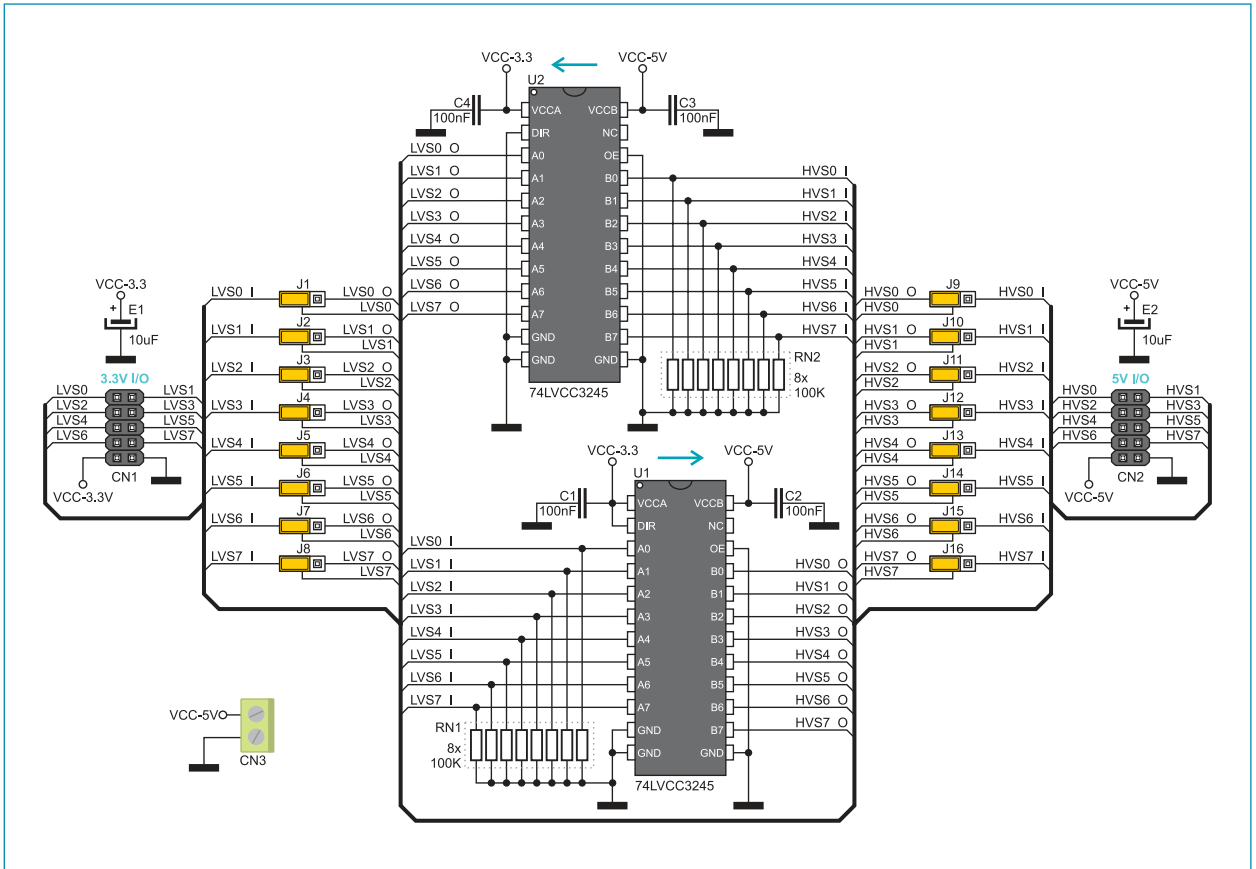

Figure 6: 3.3V-5V VOLTAGE TRANSLATOR board connection schematic



MikroElektronika
SOFTWARE AND HARDWARE SOLUTIONS FOR EMBEDDED WORLD ...making it simple

If you want to learn more about our products, please visit our website at www.mikroe.com

If you are experiencing some problems with any of our products or just need additional information, please place your ticket at www.mikroe.com/en/support

If you have any questions, comments or business proposals, do not hesitate to contact us at office@mikroe.com