

FEATURES



Q54SH12050

Quarter Brick DC/DC Power Module
40~60V in, 11.8V/51A out, 600W

The Q54SH12050 series, quarter brick, 40~60V input, single output 11.8V, isolated DC/DC converter is the latest offering from a world leader in power system and technology and manufacturing — Delta Electronics, Inc. This product provides up to 600 watts of power at 40~60V input in an industry standard footprint and pin out. With creative design technology and optimization of component placement, these converters possess outstanding electrical and thermal performances, as well as extremely high reliability under highly stressful operating conditions. The Q54SH12050 offers peak 97.8% high efficiency. The Q54SH12050 is fully protected from abnormal input/output voltage, current, and temperature conditions and meets 707V isolation. In addition, it can be connected in parallel directly for higher power without external oring-fet.

Electrical

- ◆ Peak Efficiency up to 97.8%
- ◆ PMBus Communication
- ◆ Fully regulated output voltage
- ◆ Fully protected: Input UVLO and OVP. Output OVP, OCP and OTP
- ◆ Monotonic and pre-biased startup
- ◆ No minimum load required
- ◆ Parallel Operation with Direct Output Connection
- ◆ 707Vdc isolation

Mechanical

With heat spreader size:

58.4 x 36.8 x 15.5mm (2.30"x1.45"x0.61")

With heat spreader and heat sink size:

58.4 x 36.8 x 26.5mm (2.30"x1.45"x1.04")

Safety & Reliability

- ◆ IEC/EN/UL/CSA 62368-1
- ◆ IEC/EN/UL/CSA 60950-1
- ◆ ISO 9001, TL 9000, ISO 14001, QS 9000, OHSAS18001 certified manufacturing facility

SOLDERING METHOD

- ◆ Wave soldering
- ◆ Hand soldering
- ◆ Reflow soldering (MSL of rating 3)

OPTIONS

- ◆ Negative/Positive Remote on/off
- ◆ Analog/Digital option

APPLICATIONS

- ◆ Optical Transport
- ◆ Data Networking
- ◆ Communications
- ◆ Servers

($T_a=25^{\circ}\text{C}$, airflow rate=300 LFM, $V_{in}=54\text{Vdc}$, nominal V_{out} unless otherwise noted.)

PARAMETER	NOTES and CONDITIONS				Units
		Min.	Typ.	Max.	
ABSOLUTE MAXIMUM RATINGS					
Input Voltage					Vdc
Continuous		0		60	Vdc
Transient	10mS			63	Vdc
Operating Ambient Temperature		-20		85	$^{\circ}\text{C}$
Storage Temperature		-55		125	$^{\circ}\text{C}$
Input/output Isolation Voltage				707	Vdc
INPUT CHARACTERISTICS					
Operating Input Voltage		40	54	60	Vdc
Input Under-Voltage Lockout					
Turn-On Voltage Threshold		39	39.5	40	Vdc
Turn-Off Voltage Threshold		37	38	39	Vdc
Lockout Hysteresis Voltage		1	1.5		Vdc
Input Over-Voltage Protection			62		Vdc
Maximum Input Current	Full Load, 40V _{in}		15.6	16	A
No-Load Input Current	$V_{in}=54\text{V}$, $I_o=0\text{A}$		115		mA
Off Converter Input Current	$V_{in}=54\text{V}$		15		mA
Internal Input Filter	L + C Structure		0.04+20		$\mu\text{H}+\mu\text{F}$
Internal Input Ripple Current			100		mArms
OUTPUT CHARACTERISTICS					
Output Voltage Set Point	$V_{in}=54\text{V}$, $I_o=\text{Open Load}$, $T_c=25^{\circ}\text{C}$ $V_{in}=54\text{V}$, $I_o=\text{Full Load}$, $T_c=25^{\circ}\text{C}$	12.16 11.76	12.20 11.80	12.24 11.84	Vdc Vdc
Output Regulation					
Load Regulation	$V_{in}=54\text{V}$, $I_o=I_o \text{ min to } I_o \text{ max}$		400		mV
Line Regulation	$V_{in}=40\text{V to } 60\text{V}$, $I_o=0$			0.4	% $V_{o,set}$
Temperature Regulation	$T_a=-20^{\circ}\text{C to } 85^{\circ}\text{C}$	-1	0	1	% $V_{o,set}$
Total Output Voltage Range	Over sample load, line and temperature	11.6		12.4	V
Output Voltage Ripple and Noise	5Hz to 20MHz bandwidth				
Peak-to-Peak	Full Load, $C_o=660\mu\text{F}(100\mu\text{F MLCC}+560\mu\text{F Oscon})$		85	120	mV
RMS	Full Load, $C_o=660\mu\text{F}(100\mu\text{F MLCC}+560\mu\text{F Oscon})$		25	50	mV
Operating Output Current Range		0		51	A
Output Over Current Protection(hiccup mode)	when $V_o<10\%V_{o,nom}$	110	120	130	% $I_{o,max}$
Output Over Voltage Protection(hiccup mode)				13.5	V
DYNAMIC CHARACTERISTICS					
Output Voltage Current Transient	$C_o=4500\mu\text{F}(100\mu\text{F MLCC}+4400\mu\text{F Oscon})$, 1A/ μs				
Positive Step Change in Output Current	75% $I_{o,max}$ to 50% $I_{o,max}$		125		mV
Negative Step Change in Output Current	50% $I_{o,max}$ to 75% $I_{o,max}$		125		mV
Settling Time (within 1% nominal V_{out})			200		μs
Turn-On Delay Time					
Start-Up Delay Time From Input Voltage	On/Off=On, from $V_{in}=\text{Turn-on threshold to } V_o=10\%V_{o,nom}$	30		70	mS
Start-Up Delay Time From On/Off Control	$V_{in}=V_{in,nom}$, from On/Off=On to $V_o=10\%V_{o,nom}$	0		10	mS
Output Voltage Rise Time	$V_o=10\%$ to $90\%V_{o,nom}$	5		40	mS
Output Capacitance Range		660		4500	μF
EFFICIENCY					
Peak Efficiency	65% Load @ $V_{in}=54\text{Vdc}$		97.8		%
Full Load Efficiency	100% Load @ $V_{in}=54\text{Vdc}$		97.5		%
ISOLATION CHARACTERISTICS					
Input to Output				707	Vdc
Isolation Capacitance			80		nF
FEATURE CHARACTERISTICS					
Switching Frequency	$V_{in}=40\text{--}60\text{V}$	290		1000	KHz
On/Off Control, Negative Remote On/Off logic					
Logic Low (Module On)	$V_{on/off}$			0.8	V
Logic High (Module Off)	$V_{on/off}$	2.4		20	V
ON/OFF Current	$I_{on/off}$ at $V_{on/off}=0.0\text{V}$			0.2	mA
Leakage Current	Logic High, $V_{on/off}=15\text{V}$	10		500	μA
GENERAL SPECIFICATIONS					
MTBF	$I_o=80\%$ of $I_{o,max}$; $T_a=25^{\circ}\text{C}$	2			Mhours
Weight	With Base-plate		80g		grams
Weight	With heat-spreader and heat-sink		103g		grams
Over-Temperature Shutdown (With Base-plate)	Refer to Figure 16 for Hot spot 1 location (54V _{in} , 80% I _o , 200LFM, Airflow from V _{in+} to V _{in-})		127		$^{\circ}\text{C}$
Over-Temperature Shutdown (With 0.5" Height Longitudinal Heat Sink QLL050A)	Refer to Figure 18 for Hot spot 2 location (54V _{in} , 80% I _o , 200LFM, Airflow from V _{out} to V _{in})		125		$^{\circ}\text{C}$
Over-Temperature Shutdown (NTC Resistor)			130		$^{\circ}\text{C}$

Note: Please attach thermocouple on NTC resistor to test OTP function, the hot spots' temperature is just for reference.

PARAMETER	NOTES and CONDITIONS	Min.	Typ.	Max.	Units
		PMBUS SIGNAL INTERFACE CHARACTERISTICS			
Logic Input Low (V_{IL})	Data, SMBAlert, Clock pin	0		0.8	V
Logic Input High (V_{IH})	Data, SMBAlert, Clock pin	2.4		3.6	V
Logic Output Low (V_{OL})	Data, SMBAlert, Clock pin; IOL=4mA			0.4	V
Logic Output High (V_{OH})	Data, SMBAlert, Clock pin; IOH=-4mA	2.5			V
PMBus Operating Frequency Range		100		400	KHz
PMBUS MONITORING CHARACTERISTICS					
Output Current Reading Accuracy	$V_{in}=54V, I_o=50\% \sim 100\%$ of I_o , max;	-5		+5	%
Output Voltage Reading Accuracy	$V_{in}=54V, I_o=5\% \sim 50\%$ of I_o , max;	-1.5		+1.5	A
Input Voltage Reading Accuracy		-2		+2	%
Temperature Reading Accuracy		-4		+4	%
		-5		+5	°C

PIN DEFINITION

Pin#	Name	Function	Pin#	Name	Function
1	VIN(+)	Source input voltage	7	Sig_GND	Signal ground
2	ON/OFF	Primary on/off control pin	8	Data	PMBus data line
3	VIN(-)	Input return	9	SMBAlert	PMBus SMBAlert line
4	VOUT(-)	Negative output voltage	10	Clock	PMBus clock line
5	VOUT(+)	Positive output voltage	11	Addr1	ADDR1 pin sets the high order digit of the address.
6	C2	PGOOD pin, and this pin also could be configured as secondary on/off control pin	12	Addr0	ADDR0 pin sets the low order digit of the address.

SIMPLIFIED APPLICATION CIRCUIT

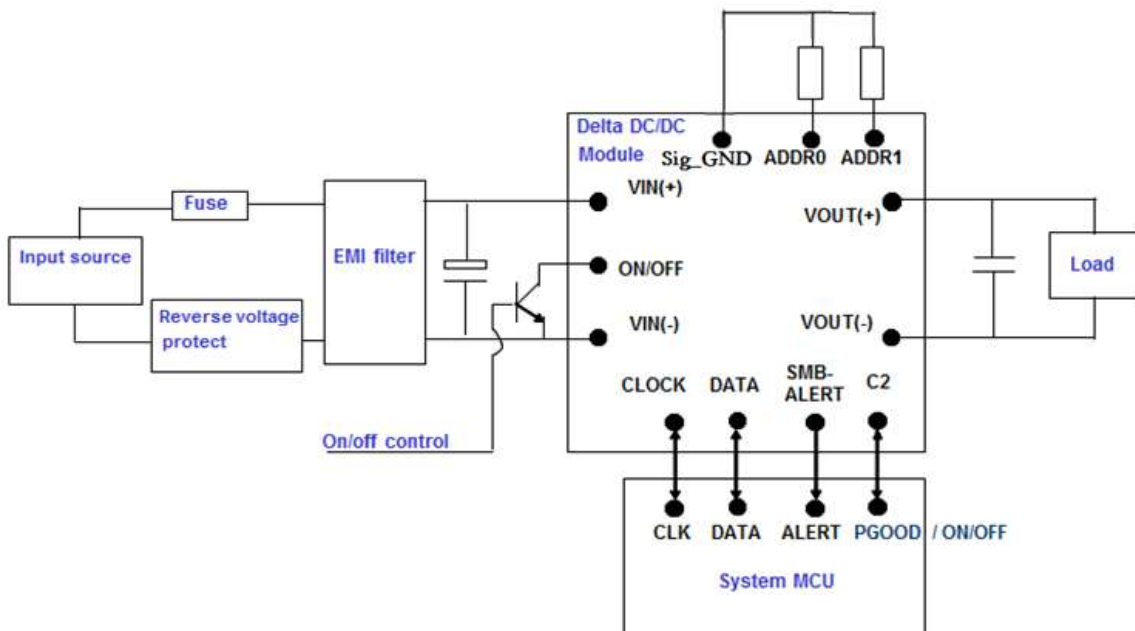

Ta=25°C

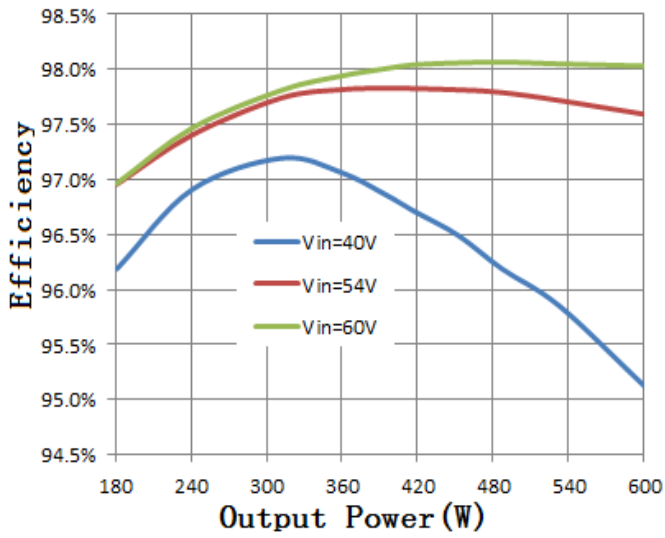

Figure 1: Efficiency vs. Output Power

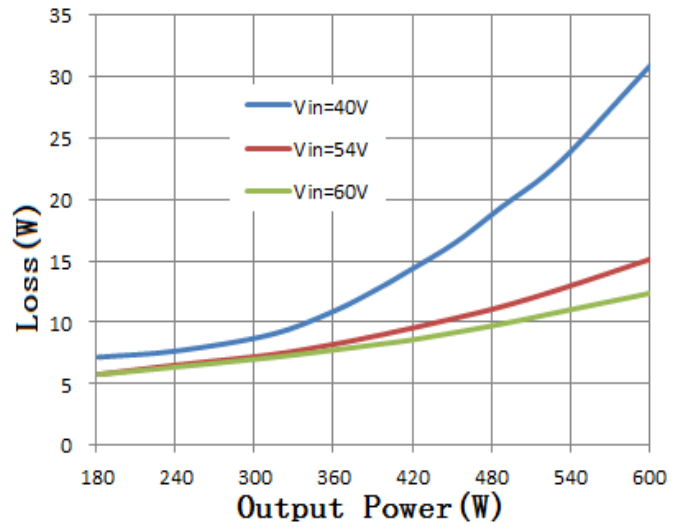

Figure 2: Loss vs. Output Power

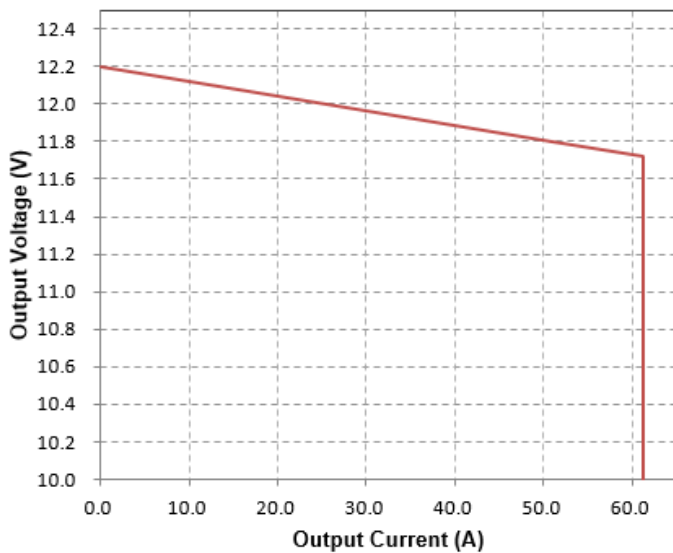

Figure 3: Output Voltage vs. Output Current showing typical current limit curves and converter shutdown points. Vin=54V

$T_A=25^{\circ}\text{C}$,

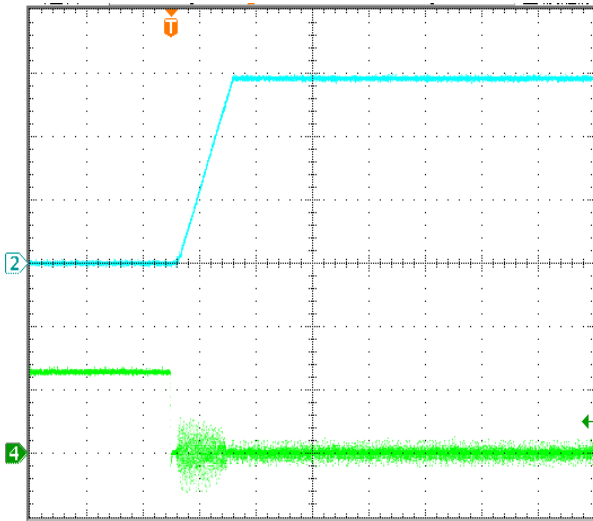

Figure 4: Remote On/Off (negative logic) at full load

$V_{in}=54\text{V}$, $I_{out} = I_{o, \max}$

Time: 10ms/div.

V_{out} (top trace): 4V/div;

$V_{\text{remote On/Off signal}}$ (bottom trace): 2V/div.

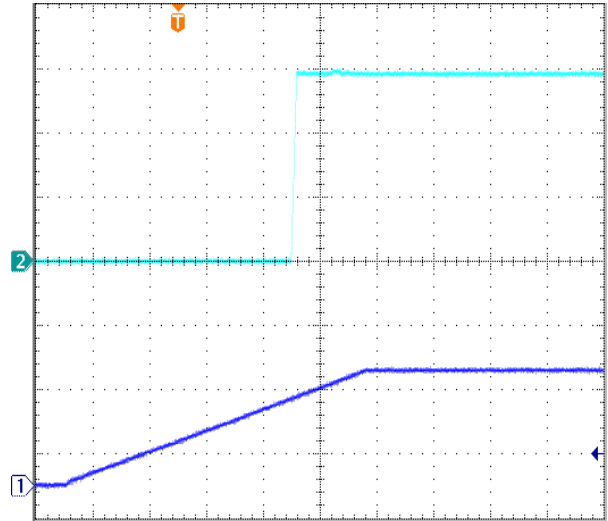

Figure 5: Input Voltage Start-up at full load

$V_{in}=54\text{V}$, $I_{out} = I_{o, \max}$

Time: 100ms/div.

V_{out} (top trace): 4V/div;

V_{in} (bottom trace): 30V/div.

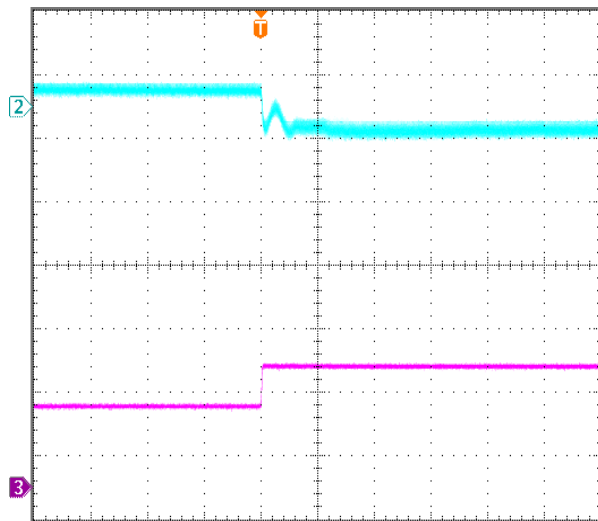

Figure 6: Transient Response

($V_{in}=54\text{V}$, 1A/ μs step change load from 50% to 75% of $I_{o, \max}$)

V_{out} (top trace): 0.2 V/div, 400us/div;

I_{out} (bottom trace): 20A/div.

Scope measurement should be made using a BNC cable (length shorter than 20 inches). Position the load between 51 mm to 76 mm (2 inches to 3 inches) from the module

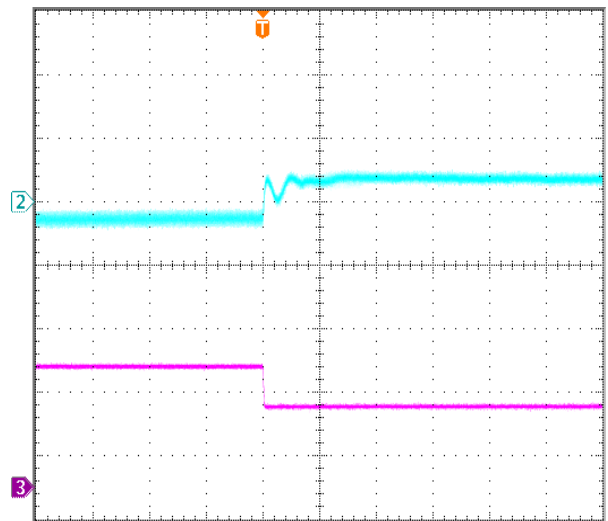

Figure 7: Transient Response

($V_{in}=54\text{V}$, 1A/ μs step change load from 75% to 50% of $I_{o, \max}$)

V_{out} (top trace): 0.2V/div, 400us/div;

I_{out} (bottom trace): 20A/div.

Scope measurement should be made using a BNC cable (length shorter than 20 inches). Position the load between 51 mm to 76 mm (2 inches to 3 inches) from the module

$T_A=25^{\circ}\text{C}$, $V_{in}=54\text{Vdc}$

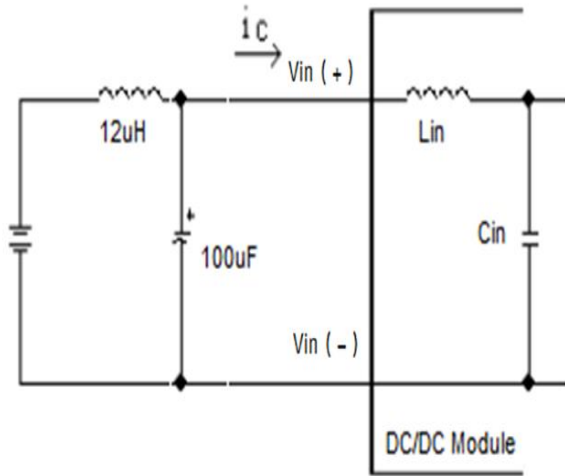

Figure 8: Test Setup Diagram for Input Ripple Current
 Note: Measured input reflected-ripple current with a simulated source Inductance of $12\mu\text{H}$. Measure current as shown above.

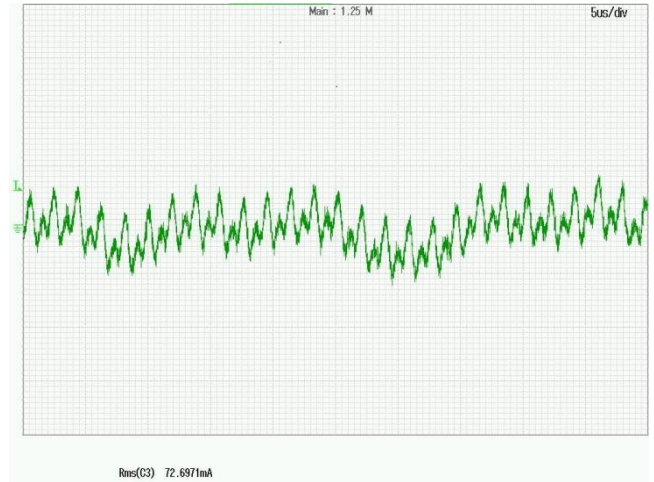

Figure 9: Input Terminal Ripple Current, i_c , at max output current and nominal input voltage with $12\mu\text{H}$ source impedance and $100\mu\text{F}$ electrolytic capacitor (200 mA/div, 5us/div).

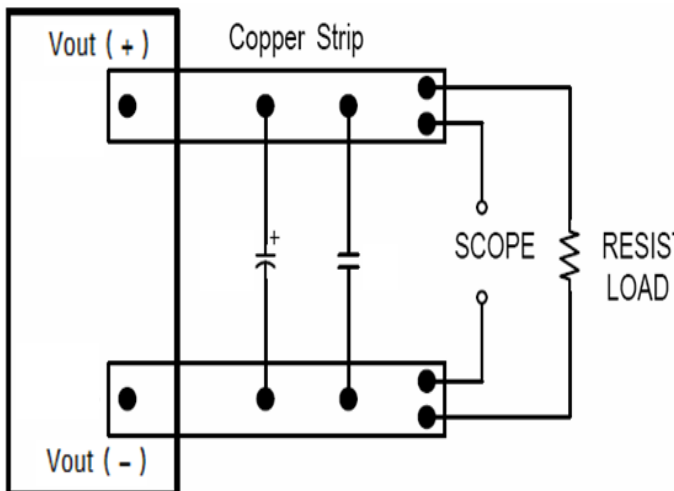

Figure 10: Test Setup for Output Voltage Noise and Ripple

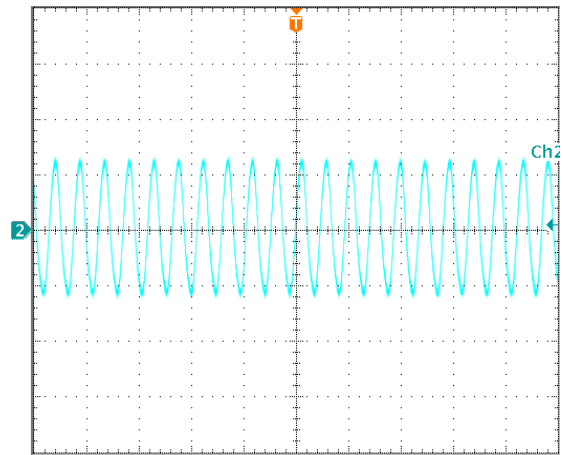

Figure 11: Output Voltage Ripple and Noise at nominal input voltage and max load current (20 mV/div, 2us/div)
 Load cap: $660\mu\text{F}$ ($100\mu\text{F}$ MLCC+ $560\mu\text{F}$ Oscon).
 Bandwidth: 20MHz.

Input Source Impedance

The impedance of the input source connecting to the DC/DC power modules will interact with the modules and affect the stability. A low ac-impedance input source is recommended. A low ESR electrolytic capacitor higher than 100 μ F (ESR < 0.7 Ω at 100kHz) is suggested.

Layout and EMC Considerations

Delta's DC/DC power modules are designed to operate in a wide variety of systems and applications. For design assistance with EMC compliance and related PWB layout issues, please contact Delta's technical support team. Below is the reference design for an input filter to meet class A in CISPR 22.

Schematic and Components List

- Cin is 100 μ F low ESR Aluminum cap \times 3pcs in parallel;
- CX1 is 2.2 μ F ceramic cap \times 2pcs in parallel;
- CY1 and CY2 are 33nF ceramic cap;
- CX2 is NC;
- CY is 33nF;
- L1 and L2 are 0.32mH;
- CY3 is 100nF, R3 is 1ohm;

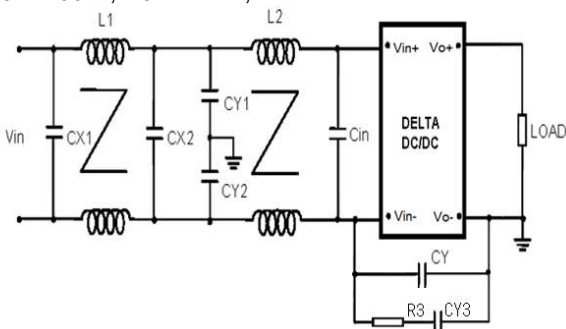

Figure 12-1: Recommended Input Filter

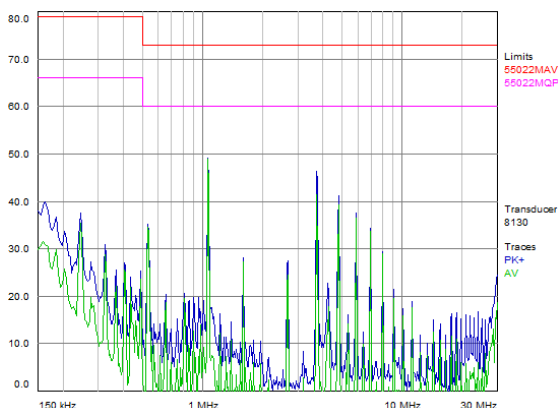

Figure 12-2: Test Result of EMC ($V_{in}=54V$, $I_o=51A$).

Note: Input EMI filter is recommended in front of power module application. For incomplete EMI circuit, EMI risk does exist in the system. For example, the parasitic inductance of long input cable may form LC resonant circuit with Y capacitance. Undesired oscillation may happen if the resonant frequency is within the switching frequency range of the power module. An RC circuit (R3/CY3 are 1ohm/100nF) as shown in Figure 12 is strongly recommended even there is no EMI requirement for the DCDC converter. If customer encounter any EMI issue. Please contact Delta design team for solution.

Safety Considerations

The power module must be installed in compliance with the spacing and separation requirements of the end user's safety agency standard, i.e., UL60950-1, CSA C22.2 NO. 60950-1 2nd and IEC 60950-1 2nd: 2005 and EN 60950-1 2nd: 2006+A11+A1: 2010, IEC 62368-1: 2014 (2nd edition), EN 62368-1: 2014 (2nd edition), UL 62368-1, 2nd Edition, 2014-12-01 and CSA C22.2 No. 62368-1-14, 2nd Edition, 2014-12. if the system in which the power module is to be used must meet safety agency requirements.

Both the input and output of this product meet SELV requirement. This module has function insulation with 707Vdc isolation. This power module is not internally fused. To achieve optimum safety and system protection, an input line fuse is highly recommended. The safety agencies require a fast-blow fuse with 20A maximum rating to be installed in the ungrounded lead. A lower rated fuse can be used based on the maximum inrush transient energy and maximum input current.

Soldering and Cleaning Considerations

Post solder cleaning is usually the final board assembly process before the board or system undergoes electrical testing. Inadequate cleaning and/or drying may lower the reliability of a power module and severely affect the finished circuit board assembly test. Adequate cleaning and/or drying is especially important for un-encapsulated and/or open frame type power modules. For assistance on appropriate soldering and cleaning procedures, please contact Delta's technical support team.

Remote On/Off

The remote on/off feature on the module is negative logic. Negative logic turns the module on during a logic low and off during a logic high. Remote on/off can be controlled by an external switch between the on/off terminal and the Vin (-) terminal. The switch can be an open collector or open drain. For negative logic if the remote on/off feature is not used, please short the on/off pin to Vin (-). If the remote on/off signal has a large noise, and a RC (R1 is 499 ohm; C1 is 4.7nF) filter circuit is recommended.

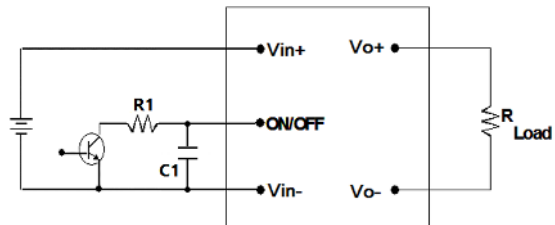

Figure 13: Remote On/Off Implementation

Over-Current Protection

The modules include an internal output over-current protection circuit, which will endure current limiting for an unlimited duration during output overload. If the output current exceeds the OCP set point, the modules will shut down (hiccup mode). The modules will try to restart after shutdown. If the overload condition still exists, the module will shut down again. This restart trial will continue until the

Over-Voltage Protection

The modules include an internal input over-voltage protection circuit, which monitors the voltage on the input terminals. If this voltage exceeds the over-voltage set point, the protection circuit will shut down, and then restart with a time delay after the fault no longer exist.

Over-Temperature Protection

The over-temperature protection consists of circuitry that provides protection from thermal damage. If the temperature exceeds the over-temperature threshold the module will shut down. The module will restart after the temperature is within specification.

Parallel and Droop Current Sharing

The modules are capable of operating in parallel, and realizing current sharing by droop current sharing method. There is about 400mV output voltage droop from 0A to full output Load, and there is no current sharing pin. By connecting the Vin pin and the Vo pin of the parallel module together, the current sharing can be realized automatically.

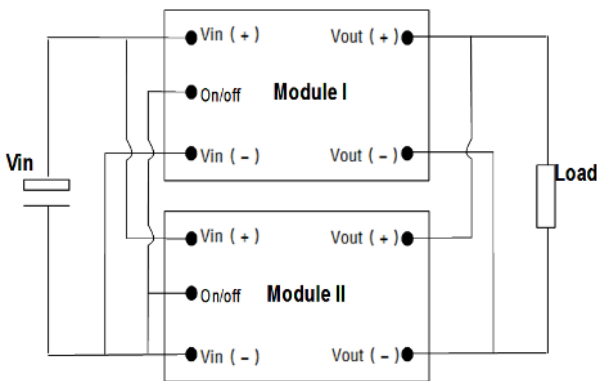

Figure 14: Parallel and droop current sharing configuration for no redundancy requirement system

If system has no redundancy requirement, the module can be parallel directly for higher power without adding external oring-fet; whereas, if the redundancy function is required, the external oring-fet should be added.

For a normal parallel operation, the following precautions must be observed:

1. The current sharing accuracy equation is:

$$X\% = \frac{|(I_{o1} + I_{o2})/2 - I_{o2}|}{I_{rated}}$$
 Where,
 I_{o1} is the output current of module1;
 I_{o2} is the output current of module2
 I_{rated} is the rated full load current of per module.
2. To ensure a better steady current sharing accuracy, below design guideline should be followed:
 - a) The inputs of the converters must be connected to the same voltage source; and the PCB trace resistance from Input voltage source to Vin+ and Vin- of each converter should be equalized as much as possible.
 - b) The PCB trace resistance from each converter's output to the load should be equalized as much as possible.

- c) For accurate current sharing accuracy test, the module should be soldered in order to avoid the unbalance of the touch resistance between the modules to the test board.

3. To ensure the parallel module can start up monotonically without triggering the OCP circuit, below design guideline should be followed:

- a) Before all the parallel modules finished start up, the total load current should be lower than the rated current of 1 module.

- b) The ON/OFF pin of the converters should be connected together to keep the parallel modules start up at the same time.

- c) The under voltage lockout point will slightly vary from unit to unit. The dv/dt of the rising edge of the input source voltage must be greater than 1V/ms to ensure that the parallel module start up at the same time.

Configurable Control Pins

The module contains one configurable control pins C2, referenced to the module secondary SIG_GND. See Mechanical Views for pin locations. The following table list the default factory configurations for the functions assigned to the pin.

Pin Designation/Function	Configuration
C2	
Power Good	Factory Default
On/Off	Optional Via PMBUS

Note: Power Good is Open-drain output.

DIGITAL FEATURE DESCRIPTIONS

The module has a digital PMBus interface to allow the module to be monitored, controlled and configured by the system. The module supports 4 PMBus signal lines, Data, Clock, SMBALERT (optional), Control (C2 pin, optional), and 2 Address line Addr0 and Addr1. More detail PMBus information can be found in the PMB Power Management Protocol Specification, Part I and part II, revision 1.2; which is shown in <http://pmbus.org>. 100kHz to 400kHz bus speeds are supported by the module. Connection for the PMBus interface should be following the High Power DC specifications given in section 3.1.3 in the SMBus specification V2.0 or the Low Power DC specifications in section 3.1.2. The complete SMBus specification is shown in <http://smbus.org>.

Note: If a series of commands consecutively sending to this module more than 30ms time, the bus free time between stop and start condition (TBUF) that defined in SMBUS AC specifications should not be all less than 200us in these commands.

The module supports the Packet Error Checking (PEC) protocol. It can check the PEC byte provided by the PMBus master, and include a PEC byte in all message responses to the master.

SMBALERT protocol is also supported by the module. SMBALERT line is also a wired-AND signal; by which the module can alert the PMBUS master via pulling the SMBALERT pin to an active low. There is only one way that the master and the module response to the alert of SMBALERT line.

This way is for the module used in a system that does not support Alert Response Address (ARA). The module is to retain its resistor programmed address, when it is in an ALERT active condition. The master will communicate with the slave module using the programmed address, and using the various READ_STATUS commands to find who cause for the SMBALERT. The CLEAR_FAULTS command will clear the SMBALERT.

The module contains a data flash used to store configuration settings, which will not be programmed into the device data flash automatically. The STORE_DEFAULT_ALL command must be used to commit the current settings are transfer from RAM to data flash as device defaults.

PMBUS Addressing

The Module has flexible PMBUS addressing capability. When connect different resistor from Addr0 and Addr1 pin to Sig_GND pin, 64 possible 7bits addresses can be acquired. The address is in the form of octal digits; each pin offers one octal digit, and then combine together as decimal format to form the decimal address as shown in below.

$$\text{Address} = 8 * \text{ADDR1} + \text{ADDR0}$$



Corresponded to each octal digit, the requested resistor values are shown in below, and +/-1% resistors accuracy can be accepted. If there are any resistances exceeding the requested range, address 126 will be return. 0-12 and 40, 44, 45, and 55 in decimal address can't be used, since they are reserved according to the SMBus specifications, and which will also return address 126.

Octal digit	Resistor(Kohm)
0	10
1	15.4
2	23.7
3	36.5
4	54.9
5	84.5
6	130
7	200

Black Box Function

There is a black box function realized by the page 44~63 of D-flash, which has 20K erase cycles up to 120C hotspot temp. Page 44~63, total 20 pages and 32 bytes per page, are assigned to record 20 history events. These 20 history events are recorded circularly, so the oldest event will be overwritten by new event if more than 20 events are recorded. Any shutdown events including the ENABLE ONOFF will trigger the black box to record data. The black box will stop recording data if the past 4 shutdown reason is the same. The black box will re-enable record function until it finds the past 4 shutdown reason is different. Every page has the same record content, which is shown as below:

Byte	Content
1 ~ 8	For Delta internal checking
9 ~ 11	Run_Time from turn on to off
12	For Delta internal checking
13 ~ 14	Module's temperature when off.
15 ~ 16	STATUS_WORD
17 ~ 18	Input voltage in PMBUS linear format, when module is off.
19 ~ 20	For Delta internal checking
21 ~ 22	Output current in PMBUS linear format, when module is off.
23 ~ 32	For Delta internal checking

For the Run_Time from Byte 8 to Byte 10, it records the total module run time from starting output power to module is off. After extracting Run_Time data, user should translate the Run_Time data to the actual run time, as below:
 If the Run_Time data < 65535, then the actual run time = (Run_Time) / 10000;
 If the Run_Time data >=65535, then the actual run time = (Run_Time - 65535) + 6.5535;
 The unit of the calculation result is second.
 The upper limit is (0x00FFFFE - 65535) + 6.5535 seconds. It's about 193 days. After reaching the upper limit, it will stay at the upper limit, not reset to 0.

PMBus Data Format

The module receives and report date in LINEAR format. The Exponent of the data words is fixed at a reasonable value for the command; altering the exponent is not supported. DIRECT format is not supported by the module.

For commands that set or report any voltage thresholds related to the output voltage, the module supports the linear data format consisting of a two-byte value with a 16-bit, unsigned mantissa, and a fixed exponent of -12. The format of the two data bytes is shown below:

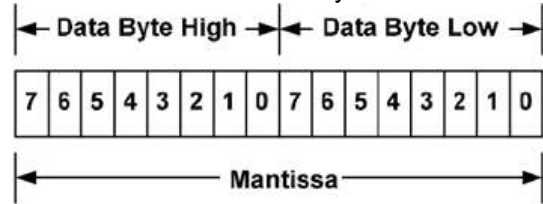

The equation can be written as:

$$V_{out} = \text{Mantissa} \times 2^{(-12)}$$

For example, considering set V_{out} to 12V by VOUT_COMMAND, the read/write data can be calculated refer to below process:

$$\text{Mantissa} = V_{out} / 2^{(-12)} = 12 / 2^{(-12)} = 49152;$$

Converter the calculated Mantissa to hexadecimal 0xC000.

For commands that set or report all other thresholds, including input voltages, output current, temperature, time and frequency, the supported linear data format is a two-byte value with: an 11 bit, two's complement mantissa, and a 5 bit, two's complement exponent (scaling factor). The format of the two data bytes is shown as in below.

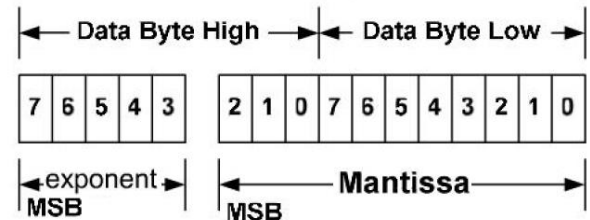

The equation can be written as:

$$\text{Value} = \text{Mantissa} \times 2^{(\text{exponent})}$$

For example, considering set the turn on threshold of input under voltage lockout to 34V by VIN_ON command; the read/write data can be calculated refer to below process:

Get the exponent of Vin, -3; whose binary is 11101
 $\text{Mantissa} = V_{in} / 2^{(-3)} = 34 / 2^{(-3)} = 272;$

Converter the calculated Mantissa to hexadecimal 110, then converter to binary 00100010000; Combine the exponent and the mantissa, 11101 and 00100010000; Converter binary 1110100100010000 to hexadecimal E910.

SUPPORTED PMBUS COMMANDS

The main PMBus commands described in the PMBus 1.2 specification are supported by the module. Partial PMBus commands are fully supported; Partial PMBus commands have difference with the definition in PMBus 1.2 specification. All the supported PMBus commands are detail summarized in below table.

Command	Command Code	Command description	Transfer type	Compatible with standard PMBus or not?	Data Format	Default value	Range limit	Data units	Exponent	Note
OPERATION	0x01	Turn the module on or off by PMBUS command	R/W byte	Refer to below description;	Bit field	0x80	/	/	/	/
ON_OFF_CONFIG	0x02	Configures the combination of primary on/off pin and PMBUS command	R/W byte	Yes	Bit field	0x1D	/	/	/	0x1D (Neg Logic); 0x1F (Pos Logic);
CLEAR_FAULTS	0x03	Clear any fault bits that have been set	Send byte	Yes	/	/	/	/	/	/
WRITE_PROTECT	0x10	Control writing to the PMBUS device.	R/W byte	Yes	/	0x80	/	/	/	The intent of this command is to provide protection against accidental changes.
STORE_DEFAULT_ALL	0x11	Stores operating parameters from RAM to data flash	Send byte	Yes	/	/	/	/	/	The FLASH must be unlocked (referring to Command 0xEC) before sending this command.
RESTORE_DEFAULT_ALL	0x12	Restores operating parameters from data flash to RAM	Send byte	Yes	/	/	/	/	/	This command can't be issued when the power unit is running.
CAPABILITY	0x19	provides some key information of a PMBus device	Read Byte	Yes	/	0xB0	/	/	/	
SMBALERT_MASK	0x1B	used to prevent a warning or fault condition from asserting the SMBALERT# signal	Write Word/ Block Wr. Block Rd. Proc. Call	Refer to below description;	/	/	/	/	/	PMBUS communication faults do not assert SMBALERT# signal by default.
VOUT_MODE	0x20	Read Vo data format	Read byte	Yes	mode+exp	0x14	/	/	/	/
VOUT_COMMAND	0x21	Read the output voltage	Read word	Yes	Vout Linear	12.2	/	Volts	-12	/
VIN_ON	0x35	Read the turn on voltage threshold of Vin under voltage lockout	Read word	Yes	Vin Linear	39.5		V	-3	/
VIN_OFF	0x36	Read the turn off voltage threshold of Vin under voltage lockout	Read word	Yes	Vin Linear	38		V	-3	/
VOUT_OV_FAULT_LIMIT	0x40	Set the output overvoltage fault threshold.	Read word	Yes	Vout Linear	13.5		V	-12	Must be higher than the value of VOUT_COMMAND and VOUT_OV_WARN_LIMIT;
VOUT_OV_WARN_LIMIT	0x42	Set a threshold causing an output voltage high warning.	R/W word	Yes	Vout Linear	13	12.5~13.5	V	-12	Must be the same or less than VOUT_OV_FAULT_LIMIT value
IOUT_OC_FAULT_LIMIT	0x46	Set the output overcurrent fault threshold.	Read word	Yes	Iout Linear	60		A	-3	Must be greater than IOUT_OC_WARN_LIMIT value
IOUT_OC_WARN_LIMIT	0x4A	Set a threshold causing an output current high warning.	R/W word	Yes	Iout Linear	55	45~55	A	-3	Must be less than IOUT_OC_FAULT_LIMIT value
OT_FAULT_LIMIT	0x4F	Set the over temperature fault threshold.	R/W word	Yes	TEMP Linear	135	100~135	°C	-2	Must be greater than OT_WARN_LIMIT value

Command	Command Code	Command description	Transfer type	Compatible with standard PMBUS or not?	Data Format	Default value	Range limit	Data units	Exponent	Note
OT_WARN_LIMIT	0x51	Set a threshold causing a temperature high warning.	R/W word	Yes	TEMP Linear	100	85~130	°C	-2	Must be less than OT_FAULT_LIMIT value
VIN_OV_FAULT_LIMIT	0x55	Set the input overvoltage fault threshold.	Read word	Yes	Vin Linear	62		V	-3	/
POWER_GOOD_ON	0x5E	Sets the output voltage at which the bit 3 of STATUS_WORD high byte should be asserted.	Read word	Yes	Vout Linear	11.4		V	-12	Must be greater than POWER_GOOD_OFF value
POWER_GOOD_OFF	0x5F	Sets the output voltage at which the bit 3 of STATUS_WORD high byte should be negated.	Read word	Yes	Vout Linear	11.2		V	-12	Must be less than POWER_GOOD_ON value
TON_DELAY	0x60	Sets the time from a start condition is received until the output voltage starts to rise	R/W word	Yes	Time Linear	22	22~500	ms	-1	/
TON_RISE	0x61	Sets the time from the output starts to rise until the voltage has entered the regulation band.	R/W word	Yes	Time Linear	10	10~30	ms	-1	/
STATUS_WORD	0x79	Returns the information with a summary of the module's fault/warning	Read word	Refer to below description;	Bit field	/	/	/	/	/
STATUS_VOUT	0x7A	Returns the information of the module's output voltage related fault/warning	Read byte	Refer to below description;	Bit field	/	/	/	/	/
STATUS_IOUT	0x7B	Returns the information of the module's output current related fault/warning	Read byte	Refer to below description;	Bit field	/	/	/	/	/
STATUS_INPUT	0x7C	Returns the information of the module's input over voltage and under voltage fault	Read byte	Refer to below description;	Bit field	/	/	/	/	/
STATUS_TEMPERATURE	0x7D	Returns the information of the module's temperature related fault/warning	Read byte	Refer to below description;	Bit field	/	/	/	/	/
STATUS_CML	0x7E	Returns the information of the module's communication related faults.	Read byte	Refer to below description;	Bit field	/	/	/	/	/
READ_VIN	0x88	Returns the input voltage of the module	Read word	Yes	Vin Linear	/	/	V	-3	/
READ_VOUT	0x8B	Returns the output voltage of the module	Read word	Yes	Vout Linear	/	/	V	-12	/
READ_IOUT	0x8C	Returns the output current of the module	Read word	Yes	Iout Linear	/	/	A	-3	/
READ_TEMPERATURE_1	0x8D	Returns the module's hot spot temperature of the module	Read word	Yes	TEMP Linear	/	/	°C	-2	/
FREQUENCY_SWITCH	0x95	Read the switching frequency	Read word	Yes	Frequency linear	NA		KHz	-1	/
PMBUS_REVISION	0x98	Reads the revision of the PMBus	Read byte	Yes	Bit field	0x22	/	/	/	/
MFR_REVISION	0x9B	Read the revision number of the module.	Read Block	Yes	ASCII	/	/	/	/	The format is "SX.X"
ERASE_BLACKBOX_DATA	0xD1	Erase all black box data.	Send byte	Refer to below description;	/	/	/	/	/	/
READ_HISTORY_EVENT_NUMBER	0xD2	Read the total number of history event in black box space.	Read byte	Refer to below description;	/	/	/	/	/	/
READ_HISTORY_EVENTS	0xD6	Read history event from black box	Read block	Refer to below description;	/	/	/	/	/	/
SET_HISTORY_EVENT_OFFSET	0xD7	Set history event offset	R/W byte	Refer to below description;	/	/	/	/	/	/
MFR_C1_C2_ARA_CONFIG	0xE0	Configure C2 pin function	R/W byte	Refer to below description;	Bit field	0x00	/	/	/	/
MFR_C2_Configure	0xE1	Configure C2 pin logic	R/W byte	Refer to below description;	Bit field	0x00	/	/	/	/
MFR_PGOOD_POLARITY	0xE2	Configure Power Good logic	R/W byte	Refer to below description;	Bit field	0x01	/	/	/	Default Positive PGOOD logic
PMBUS_CMD_FLASH_KEY_WRITE	0xE3	Write the key to unlock the Flash before Storing operating parameters from RAM to data flash	R/W Block	No	/	0xA5A5A5A5		/	/	A data block:7E,15,DC,42 should be send to unlock the FLASH.

OPERATION [0x01]

Bit number	Purpose	Bit Value	Meaning	Default Settings, 0x80
7:	Enable/Disable the module	1	Output is enabled	1
		0	Output is disabled	
6:0	Reserved			0000000

ON_OFF_CONFIG [0x02]

Bit number	Purpose	Bit Value	Meaning	Default Settings , 0x1D (negative) /0x1F (positive)
7:5	Reserved			000
4	Controls how the unit responds to the primary on/off pin and the OPERATION command;	1	Module does not power up until commanded by the primary ON/OFF pin and the OPERATION	1
		0	Module power up at any time regardless of the state of the primary ON/OFF pin and the OPERATION	
3	Controls how the unit responds to the OPERATION command	1	Module responds to the 7 bit in the OPERATION	1
		0	Module ignores the 7 bit in the OPERATION	
2	Controls how the unit responds to the primary on/off pin	1	Module requires the primary ON/OFF pin to be asserted to start the unit	1
		0	Module ignores the state of the primary ON/OFF pin	
1	Control logic of primary on/off pin	1	Positive Logic	0: Negative; 1: Positive.
		0	Negative Logic	
0	Unit turn off delay time control	1	Shut down the module with 0 delay cycle	1

SMBALERT_MASK [0x1B]

Byte0 (Command)	Bit number	Purpose	Bit Value	Meaning	Default value
STATUS_VOUT	7	Reserved			0
	6	Output over voltage warning	1	Mask	0
			0	Not mask	
STATUS_IOUT	5:0	Reserved			0
	7:6	Reserved			0
			5	Output over current warning	1
		0	Not mask		
STATUS_INPUT	4:0	Reserved			0
	7:0	Reserved			0
STATUS_TEMPERATURE	7	Reserved			0
	6	Over temperature warning			0
	5:0	Reserved			0
STATUS_CML	7	Invalid/Unsupported Command Received	1	Mask	1
			0	Not mask	
	6	Invalid/Unsupported Data Received	1	Mask	1
			0	Not mask	
	5	Packet Error Check Failed	1	Mask	1
0			Not mask		
4:0	Reserved			0	
STATUS_MFR	7:0	Reserved			0

STATUS_WORD [0x79]

High byte

Bit number	Purpose	Bit Value	Meaning
7	An output voltage fault or warning	1	Occurred
		0	No Occurred
6	An output over current fault or warning	1	Occurred
		0	No Occurred
5	An input voltage fault, including over voltage and under voltage	1	Occurred
		0	No Occurred
4	Reserved		
3	Power_Good	1	is negated
		0	ok
2:0	Reserved		

Low byte

Bit number	Purpose	Bit Value	Meaning
7	Reserved		
6	OFF (The unit is not providing power to the output, regardless of the reason)	1	Occurred
		0	No Occurred
5	An output over voltage fault	1	Occurred
		0	No Occurred
4	An output over current fault	1	Occurred
		0	No Occurred
3	An input under voltage fault	1	Occurred
		0	No Occurred
2	A temperature fault or warning	1	Occurred
		0	No Occurred
1	CML (A communications, memory or logic fault)	1	Occurred
		0	No Occurred
0	Reserved		

STATUS_VOUT [0x7A]

Bit number	Purpose	Bit Value	Meaning
7	Output over voltage fault	1	Occurred
		0	No Occurred
6	Output over voltage warning	1	Occurred
		0	No Occurred
5	Output under voltage warning	1	Occurred
		0	No Occurred
4	Output under voltage fault	1	Occurred
		0	No Occurred
3:0	Reserved		

STATUS_IOUT [0x7B]

Bit number	Purpose	Bit Value	Meaning
7	Output over current fault	1	Occurred
		0	No Occurred
6	Reserved		
5	Output over current warning	1	Occurred
		0	No Occurred
4:0	Reserved		

STATUS_INPUT [0x7C]

Bit number	Purpose	Bit Value	Meaning
7	Input over voltage fault	1	Occurred
		0	No Occurred
6:5	Reserved		
4	Input under voltage fault	1	Occurred
		0	No Occurred
3:0	Reserved		

STATUS_TEMPERATURE [0x7D]

Bit number	Purpose	Bit Value	Meaning
7	Over temperature fault	1	Occurred
		0	No Occurred
6	Over temperature warning	1	Occurred
		0	No Occurred
5:0	Reserved		

STATUS_CML [0x7E]

Bit number	Purpose	Bit Value	Meaning
7	Invalid/Unsupported Command Received	1	Occurred
		0	No Occurred
6	Invalid/Unsupported Data Received	1	Occurred
		0	No Occurred
5	Packet Error Check Failed	1	Occurred
		0	No Occurred
4:0	Reserved		

MFR_C1_C2_ARA_CONFIG [0xE0]

Bit number	Purpose	Bit Value	Meaning
7:5	Reserved	000	Reserved
4	ARA	0	ARA not functional, module remains at resistor programmed address when SMBLAERT is asserted
3:0	PIN Configuration	0000	C2 pin: POWER_GOOD
		0010	C2 pin: ON/OFF (Secondary)

MFR_C2_Configure [0xE1]

Bit number	Purpose	Bit Value	Meaning
7:2	Reserved	000000	Reserved
1	ON/OFF Configuration	0	Secondary side on/off pin state when mapped to C2 is ignored
		1	AND – Primary and Secondary side on/off
0	Secondary Side ON/OFF Logic	0	Negative Logic (Low Enable: Input < 0.8V wrt Vout(-))
		1	Positive Logic (High Enable: Input > 2.0V wrt Vout(-))

MFR_PGOOD_POLARITY [0xE2]

Bit number	Purpose	Bit Value	Meaning
7:1	Reserved	0000000	Reserved
0	Power Good Logic	0	Negative PGOOD logic
		1	Positive PGOOD logic

ERASE_BLACKBOX_DATA [0xD1]

This is a Delta MFR command which used to erase all black box data. After writing the command 0xD1, the module will be powered off automatically for erasing safely. After finishing the erasing task, the module will repower on itself again. The total time for erasing is about 400ms. So the module will be powered off at least 400ms if user send a 0xD1 command to erase black box data. User should pay attention to this feature before writing 0xD1 command.

READ_HISTORY_EVENT_NUMBER [0xD2]

This is a read-only Delta MFR command which used to get the total events number in black box.

READ_HISTORY_EVENTS [0xD6]

This is a read-only Delta MFR command which used to get the history events at an appointed offset. The appointed offset can be set by command 0xD7 SET_HISTORY_EVENT_OFFSET. This command is a read block PMBUS communication protocol. So the return data from PMBUS will be as below table shows.

Byte	Content
0	Byte Count = 32
1 ~ 8	For Delta internal checking
9 ~ 11	Run_Time from turn on to off
12	For Delta internal checking
13 ~ 14	Module's temperature when off.
15 ~ 16	STATUS_WORD
17 ~ 18	Input voltage in PMBUS linear format, when module is off.
19 ~ 20	For Delta internal checking
21 ~ 22	Output current in PMBUS linear format, when module is off.
23 ~ 32	For Delta internal checking

Note: The Byte Count at Byte0 is the content of PMBUS block read protocol, not the black box data.

SET_HISTORY_EVENT_OFFSET [0xD7]

This is a Delta MFR command which used to set offset value to decide which history data for read. The offset and the history data has the fix relationship, as below table shows.

Offset	History data	Offset	History data
0x30	The latest data	0x3A	The last 10 data
0x31	The last 1 data	0x3B	The last 11 data
0x32	The last 2 data	0x3C	The last 12 data
0x33	The last 3 data	0x3D	The last 13 data
0x34	The last 4 data	0x3E	The last 14 data
0x35	The last 5 data	0x3F	The last 15 data
0x36	The last 6 data	0x40	The last 16 data
0x37	The last 7 data	0x41	The last 17 data
0x38	The last 8 data	0x42	The last 18 data
0x39	The last 9 data	0x43	The last 19 data or the now black box data

Thermal Testing Setup

Thermal management is an important part of the system design. To ensure proper, reliable operation, sufficient cooling of the power module is needed over the entire temperature range of the module. Convection cooling is usually the dominant mode of heat transfer.

Hence, the choice of equipment to characterize the thermal performance of the power module is a wind tunnel.

Delta's DC/DC power modules are characterized in heated vertical wind tunnels that simulate the thermal environments encountered in most electronics equipment. This type of equipment commonly uses vertically mounted circuit cards in cabinet racks in which the power modules are mounted.

The following figure shows the wind tunnel characterization setup. The power module is mounted on a 185mmX185mm,105 μ m (3Oz),6 layers' test PWB and is vertically positioned within the wind tunnel. The space between the neighboring PWB and the top of the power module is constantly kept at 6.35mm (0.25").

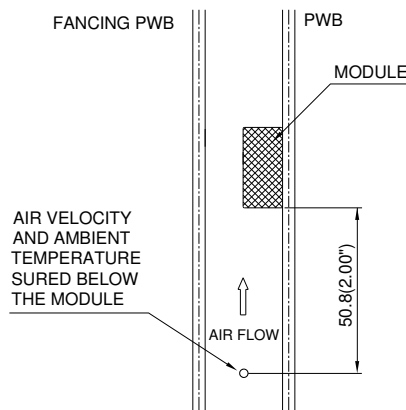

Note: Wind Tunnel Test Setup Figure Dimensions are in millimeters and (Inches)

Figure 15: Wind Tunnel Test Setup

Thermal Derating

Heat can be removed by increasing airflow over the module. To enhance system reliability, the power module should always be operated below the maximum operating temperature. If the temperature exceeds the maximum module temperature, reliability of the unit may be affected.

Thermal Curves (With Base-plate)

Thermal Curves (With 0.5" height heat sink QLL050A)

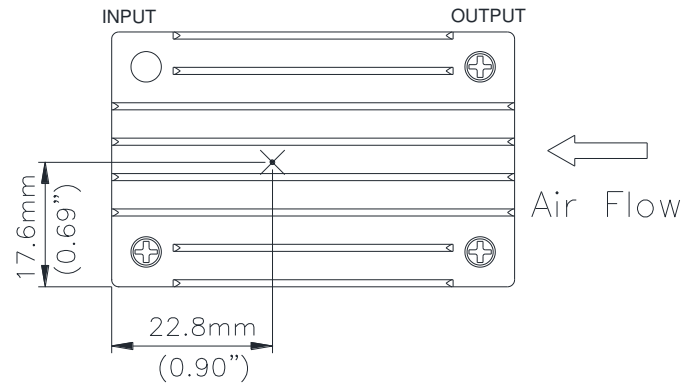
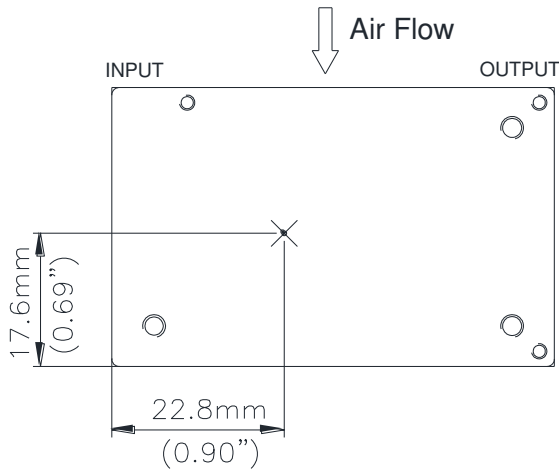

Figure 16: Hot spot 1 temperature measurement location
The allowed maximum hot spot 1 temperature is defined at 112 °C.

Figure 18: Hot spot 2 temperature measurement location
The allowed maximum hot spot 2 temperature is defined at 110 °C.

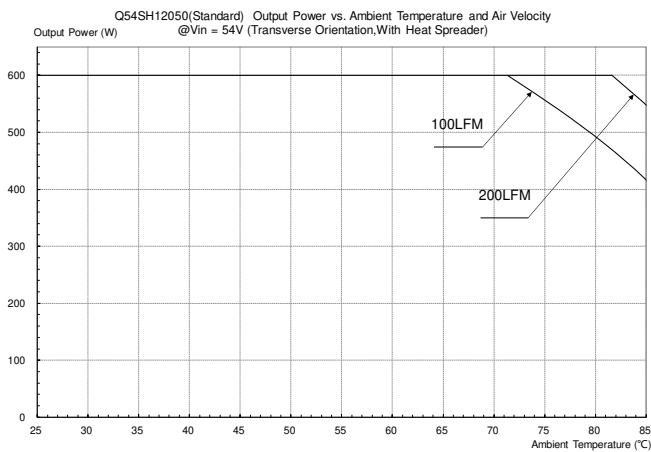

Figure 17: Output Power vs. Ambient Temperature and Air Velocity @ Vin = 54V (Transverse Orientation, Airflow from V_{in+} to V_{in-}, With Base-plate)

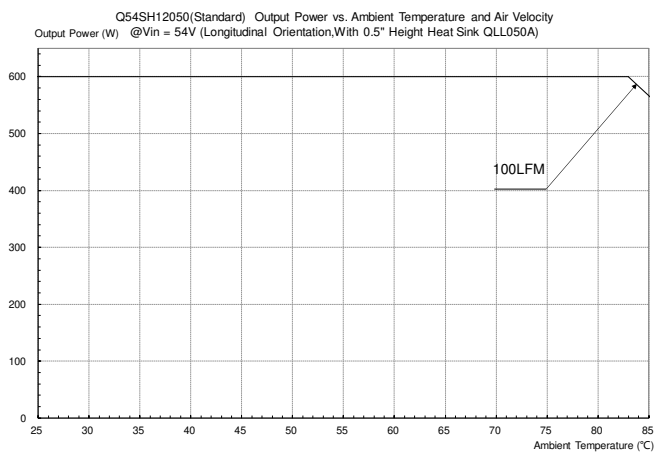
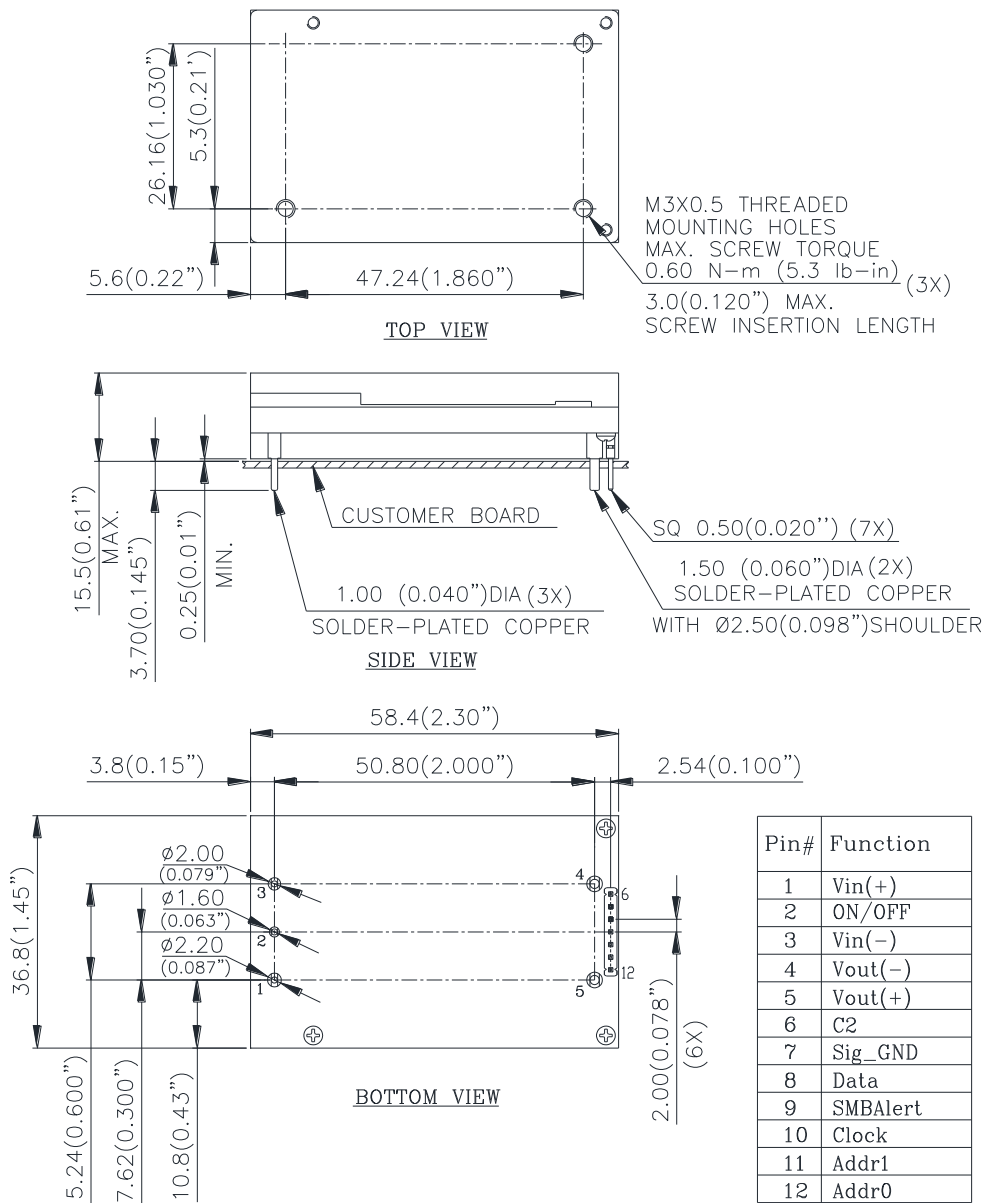

Figure 19: Output Power vs. Ambient Temperature and Air Velocity @ Vin = 54V (Longitudinal Orientation, Airflow from V_{out} to V_{in}, With 0.5" Height Heat Sink QLL050A)

Mechanical Drawing (With Baseplate)



NOTES:
DIMENSIONS ARE IN MILLIMETERS AND (INCHES)
TOLERANCES: X.Xmm±0.5mm(X.XX in.±0.02 in.)
X.XXmm±0.25mm(X.XXX in.±0.010 in.)

Pin No.	Name	Function
1	+Vin	Positive input voltage
2	ON/OFF	Remote ON/OFF
3	-Vin	Negative input voltage
4	-Vout	Negative output voltage
5	+Vout	Positive output voltage
6	C2	PGOOD pin, and this pin also could be configured as secondary on/off control pin
7	Sig_Gnd	Signal ground
8	Data	PMBus data line
9	SMBAlert	PMBus SMBAlert line
10	Clock	PMBus clock line
11	Addr1	ADDR1 pin sets the high order digit of the address.
12	Addr0	ADDR0 pin sets the low order digit of the address.

Pin Specification:

Pins 1,2,3 1.00mm (0.040") diameter; copper with matte Tin plating and Nickel under plating
Pins 4,5 1.50mm (0.060") diameter; copper with matte Tin plating and Nickel under plating
Pins 6~12 Digital pins; Square 0.50mm (0.020"); copper with golden flash plating

Mechanical Drawing (With Heat Spreader and Heat Sink)

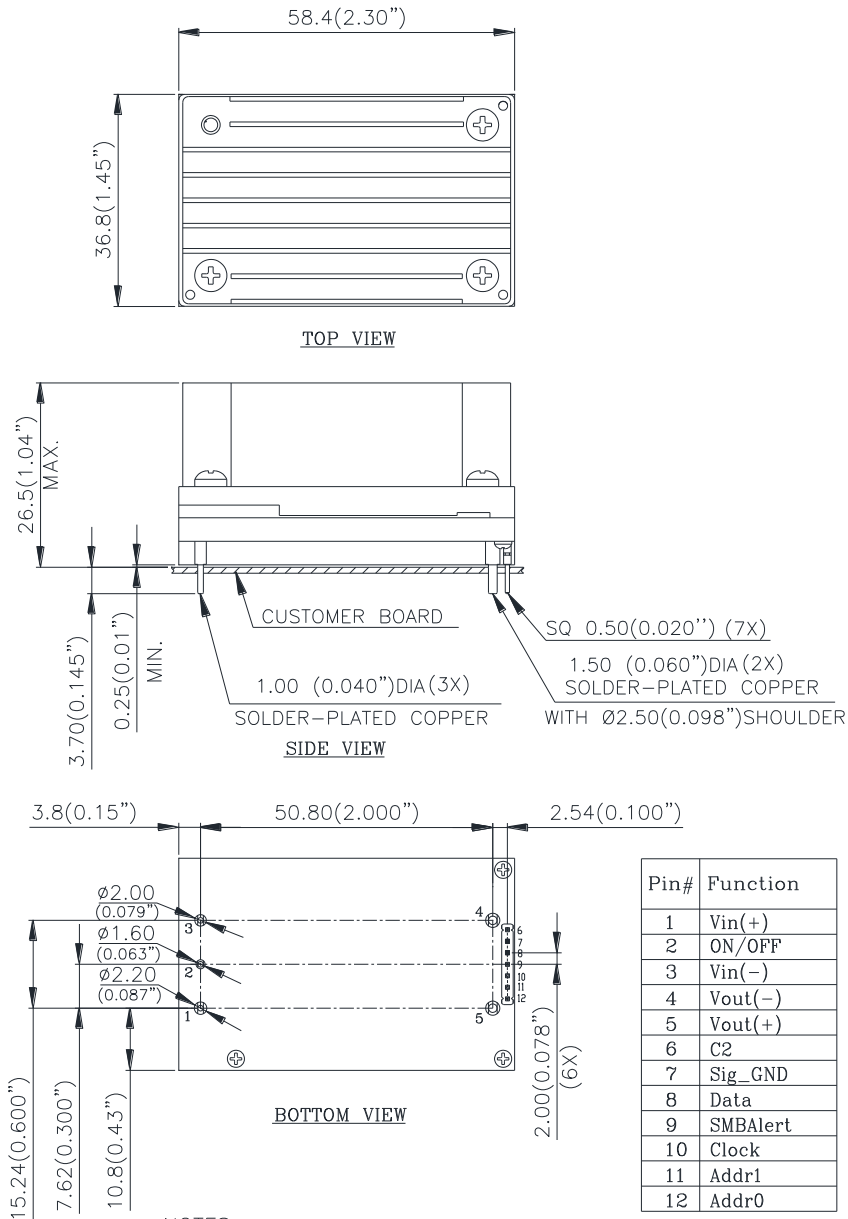

NOTES:
 DIMENSIONS ARE IN MILLIMETERS AND (INCHES)
 TOLERANCES: X.Xmm±0.5mm(X.XX in.±0.02 in.)
 X.XXmm±0.25mm(X.XXX in.±0.010 in.)

Pin No.	Name	Function
1	+Vin	Positive input voltage
2	ON/OFF	Remote ON/OFF
3	-Vin	Negative input voltage
4	-Vout	Negative output voltage
5	+Vout	Positive output voltage
6	C2	PGOOD pin, and this pin also could be configured as secondary on/off control pin
7	Sig_Gnd	Signal ground
8	Data	PMBus data line
9	SMBAlert	PMBus SMBAlert line
10	Clock	PMBus clock line
11	Addr1	ADDR1 pin sets the high order digit of the address.
12	Addr0	ADDR0 pin sets the low order digit of the address.

Pin Specification:

Pins 1,2,3 1.00mm (0.040") diameter; copper with matte Tin plating and Nickel under plating
 Pins 4,5 1.50mm (0.060") diameter; copper with matte Tin plating and Nickel under plating
 Pins 6~12 Digital pins; Square 0.50mm (0.020"); copper with golden flash plating

Recommended Pad Layout

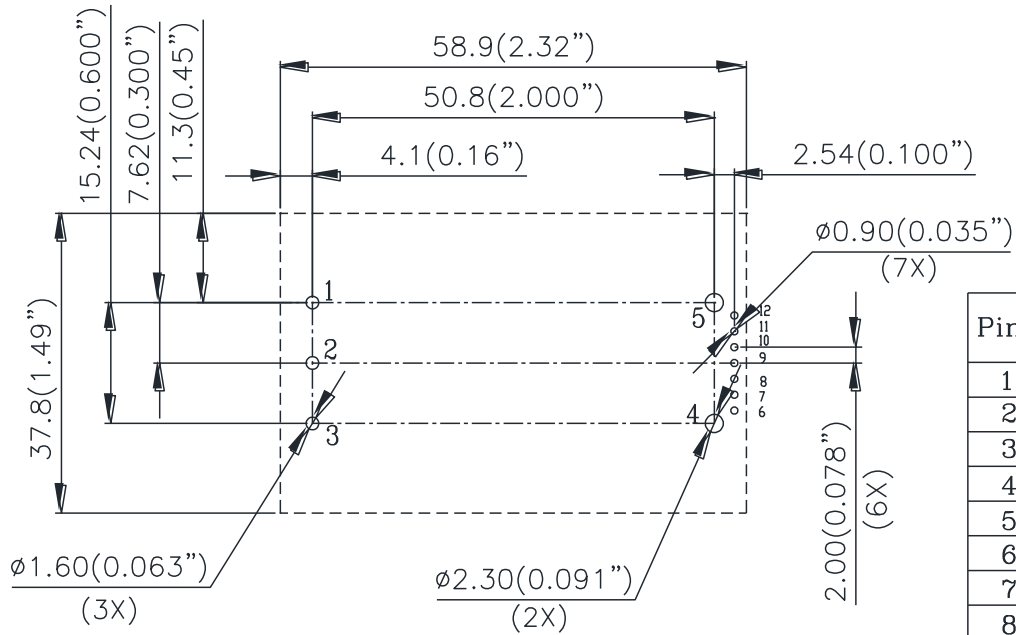

Pin#	Function
1	Vin(+)
2	ON/OFF
3	Vin(-)
4	Vout(-)
5	Vout(+)
6	C2
7	Sig_GND
8	Data
9	SMBAlert
10	Clock
11	Addr1
12	Addr0

NOTES:
 DIMENSIONS ARE IN MILLIMETERS AND (INCHES)
 TOLERANCES: X.Xmm±0.5mm(X.XX in.±0.02 in.)
 X.XXmm±0.25mm(X.XXX in.±0.010 in.)

Note: The recommended PCB hole is for reference, customer can modify system board hole design based on actual soldering performance.

Soldering method

Generally, as the most common mass soldering method for the solder attachment, wave soldering is used for through-hole power modules and reflow soldering is used for surface-mount ones. Delta recommended soldering methods and process parameters are provided in this document for solder attachment of power modules onto system board. SAC305 is the suggested lead-free solder alloy for all soldering methods.

Reflow soldering is not a suggested method for through-hole power modules due to many process and reliability concerns. If you have this kind of application requirement, please contact Delta sales or FAE for further confirmation.

Wave Soldering (Lead-free)

Delta's power modules are designed to be compatible with single-wave or dual wave soldering. The suggested soldering process must keep the power module's internal temperature below the critical temperature of 217°C continuously. The recommended wave-soldering profile is shown in following figure.

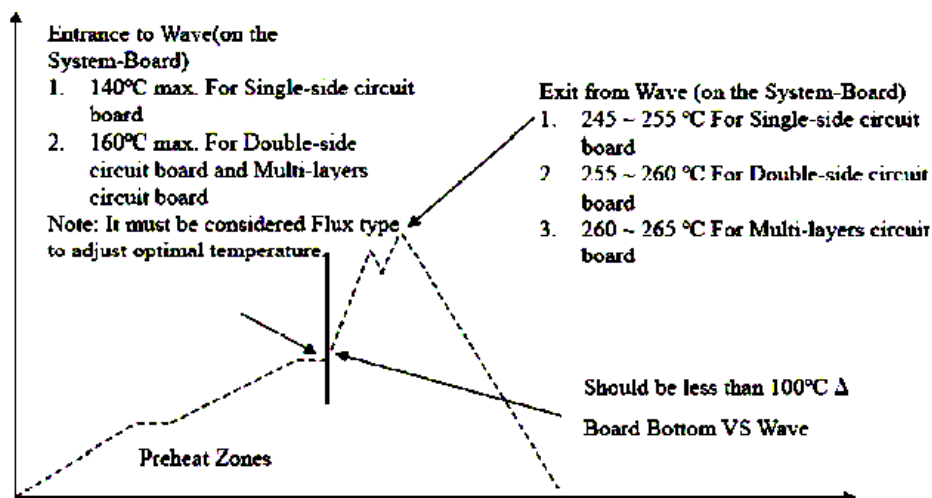

Recommended Temperature Profile for Lead-free Wave Soldering
Note: The temperature is measured on solder joint of pins of power module.

The typical recommended (for double-side circuit board) preheat temperature is 115+/-10°C on the top side (component side) of the circuit board. The circuit-board bottom-side preheat temperature is typically recommended to be greater than 135°C and preferably within 100°C of the solder-wave temperature. A maximum recommended preheat up rate is 3°C/s. A maximum recommended solder pot temperature is 255+/-5°C with solder-wave dwell time of 3~6 seconds. The cooling down rate is typically recommended to be 6°C/s maximum.

Hand Soldering (Lead Free)

Hand soldering is the least preferred method because the amount of solder applied, the time the soldering iron is held on the joint, the temperature of the iron, and the temperature of the solder joint are variable. The recommended hand soldering guideline is listed in following table. The suggested soldering process must keep the power module's internal temperature below the critical temperature of 217°C continuously.

Hand-Soldering Guideline

Parameter	Single-side Circuit Board	Double-side Circuit Board	Multi-layers Circuit Board
Soldering Iron Wattage	90	90	90
Tip Temperature	385+/-10°C	420+/-10°C	420+/-10°C
Soldering Time	2 ~ 6 seconds	4 ~ 10 seconds	4 ~ 10 seconds

Reflow Soldering (Lead-free)

High temperature and long soldering time will result in IMC layer increasing in thickness and thereby shorten the solder joint lifetime. Therefore the peak temperature over 245°C is not suggested due to the potential reliability risk of components under continuous high-temperature. In the meanwhile, the soldering time of temperature above 217°C should be less than 90 seconds. Please refer to following figure for recommended temperature profile parameters.

Shielding cap is requested to mount on DCDC module if with heat-spreader/heat-sink, to prevent the customer side high temperature of reflow to re-melt the DCDC module's internal component's soldering joint.

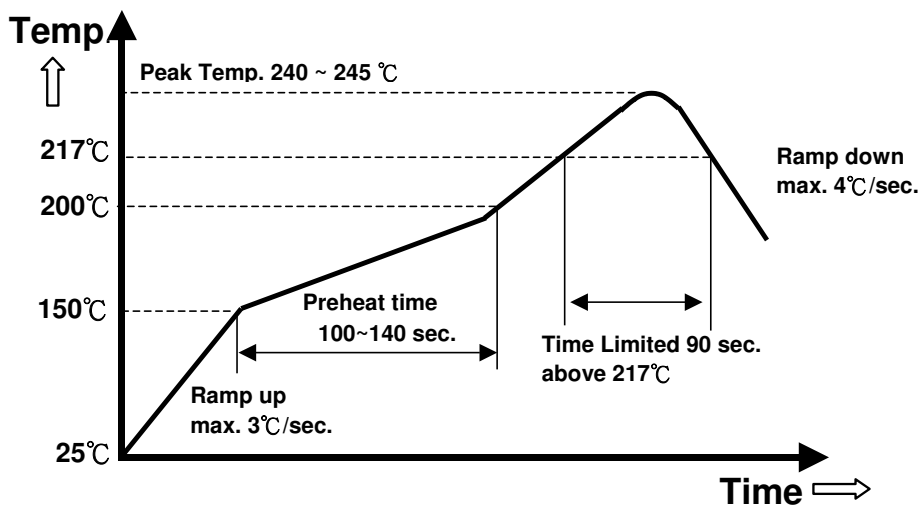

Recommended Temperature Profile for Lead-free Reflow Soldering
 Note: The temperature is measured on solder joint of pins of power module.



PART NUMBERING SYSTEM

Q	54	S	H	120	50	N	N	P ^{*note}	H
Type of Product	Input Voltage	Number of Outputs	Product Series	Output Voltage	Output Current	ON/OFF Logic	Pin Length /Type	Pin Assignment	Option Code
Q - Quarter Brick	54 - 40~60V	S - Single	H - Series Number	120 - 12V	50 - 51A	N - Negative	N - 0.145" K - 0.110"	D - Digital pins A - Analog pins P - PIH process	H - With heatspreader F - With heatspreader and heatsink

*Note: 1. D (Digital pins): With pin6~12
 2. A (Analog pins): Without pin6~12
 3. P (PIH process): With pin6~12 and support paste-in-hole reflow process with a shielding cap mounted on model.

* The Q54SH12050NNPH/Q54SH12050NKPH can be processed with paste-in-hole Pb or Pb-free reflow process, if customer using this process to mount the models and by using lead free solder paste, refer to the "Reflow soldering (lead free)" profile.

RECOMMENDED PART NUMBER

Model Name	Input		Output		Peak Eff.
Q54SH12050NNPH	40V~60V	16A	11.8V	51A	97.8%
Q54SH12050NKPH	40V~60V	16A	11.8V	51A	97.8%
Q54SH12050NKDH	40V~60V	16A	11.8V	51A	97.8%
Q54SH12050NNDH	40V~60V	16A	11.8V	51A	97.8%
Q54SH12050NNDF	40V~60V	16A	11.8V	51A	97.8%

Default remote On/Off logic is negative.
 Please contact with Delta sales/FAE for different optional functions.

CONTACT US:

Website: www.deltaww.com/dcdc

USA:

Telephone:
 East Coast: 978-656-3993
 West Coast: 510-668-5100
 Fax: (978) 656 3964

Email: dcdc@deltaww.com

Europe:

Telephone: +31-20-655-0967
 Fax: +31-20-655-0999

Asia & the rest of world:

Telephone: +886 3 4526107
 Ext. 6220~6226
 Fax: +886 3 4513485

WARRANTY

Delta offers a one (1) year limited warranty. Complete warranty information is listed on our web site or is available upon request from Delta.

Information furnished by Delta is believed to be accurate and reliable. However, no responsibility is assumed by Delta for its use, nor for any infringements of patents or other rights of third parties, which may result from its use. No license is granted by implication