

MODEL CTR - TRUE RMS AC CURRENT TRANSDUCER

- TRUE RMS OUTPUT
- JUMPER SELECTABLE RANGES
- OUTPUT IS MAGNETICALLY ISOLATED FROM THE INPUT
- SPLIT-CORE CASE



GENERAL DESCRIPTION

CTR Series transducers combine a current transformer and a signal conditioner into a single package. This provides higher accuracy, lower wiring costs, easier installation and saves valuable panel space.

The CTR Series transducers are available in 4-20 mA output only. The CTR Series provides a "True RMS" output on distorted waveforms found on VFD or SCR outputs, and on linear loads in "noisy" power environments. Select the CTR Series for variable speed or SCR controlled loads.

The current waveform of a typical linear load is a pure sine wave. In VFD and SCR applications, however, output waveforms are rough approximations of a sine wave. There are numerous spikes and dips in each cycle. CTR transducers use a mathematical algorithm called "True RMS", that integrates the actual waveform over time. The output is the amperage component of the true power (heating value) of the AC current waveform. True RMS is the only way to accurately measure distorted AC waveforms.

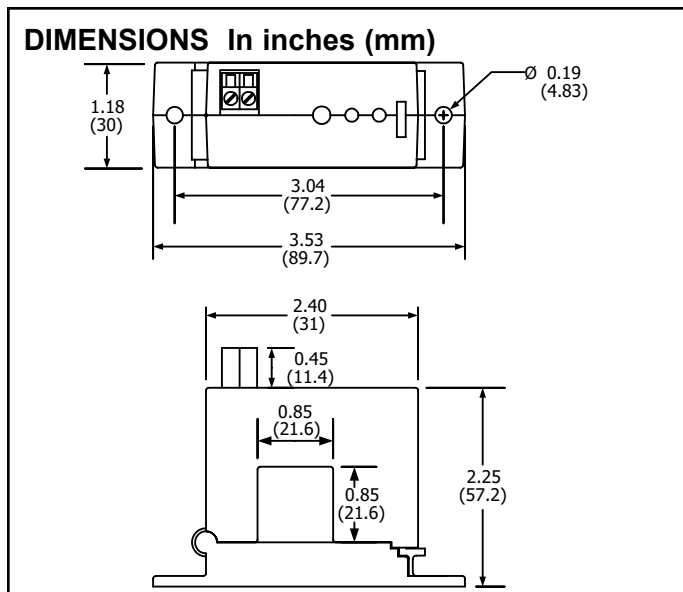
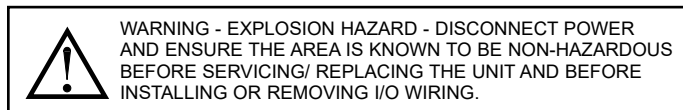

SAFETY SUMMARY

All safety related regulations, local codes and instructions that appear in the literature or on equipment must be observed to ensure personal safety and to prevent damage to either the instrument or equipment connected to it. If equipment is used in a manner not specified by the manufacturer, the protection provided by the equipment may be impaired.

Do not use this unit to directly command motors, valves, or other actuators not equipped with safeguards. To do so, can be potentially harmful to persons or equipment in the event of a fault to the unit.

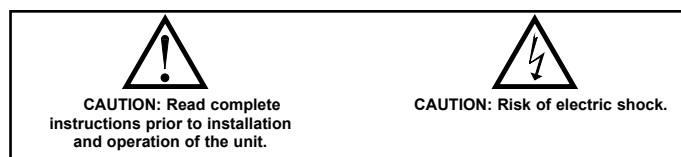

SPECIFICATIONS

1. OUTPUT SIGNAL: 4 to 20 mA DC, loop-powered, True RMS
2. OUTPUT LIMIT: 23 mA
3. FREQUENCY RANGE: 10-400 Hz (All Waveforms)
4. RESPONSE TIME: to 90% of step change 600 msec
5. ACCURACY: 0.8% FS
6. POWER SUPPLY: 24 VDC Nominal, 40 VDC Max. Must use an NEC Class 2 or Limited Power Source (LPS) rated power supply.
7. INPUT RANGES: (Jumper Selectable)

MODEL	RANGE	MAXIMUM		
		Continuous	6 sec	1 sec
CTR05	10 A	80 A	125 A	250 A
	20 A	110 A	150 A	300 A
	50 A	175 A	215 A	400 A
CTR2	100 A	200 A	300 A	600 A
	150 A	300 A	450 A	800 A
	200 A	400 A	500 A	1000 A

8. ISOLATION VOLTAGE: 3 kV
9. CASE: UL 94V-0 Flammability rated thermoplastic
10. ENVIRONMENTAL: -4 to 122 °F (-20 to 50 °C)
 0-95% RH, non-condensing
 Altitude: Up to 2000 meters
 Installation Category II, Pollution Degree 2 as defined in IEC/EN 60664-1.
11. TORQUE RATINGS: 9 in-lbs
12. LISTING: UL 508 Industrial Control Equipment, CSA C22.2 No. 14-M95, and CE Certified.

INSTALLATION

Run wire to be monitored through opening in the sensor. Be sure the monitored current flows in the same direction as the arrow on the sensor. The CTR Series transducers work in the same environment as motors, contactors, heaters, pull-boxes, and other electrical enclosures. They can be mounted in any position or hung directly on wires with a wire tie. Just leave at least one inch (25.4 mm) distance between sensor and other magnetic devices.

Split-Core Versions

Press the tab in the direction as shown to open the sensor. After placing the wire in the opening, press the hinged portion firmly downward until a definite click is heard and the tab pops out fully.

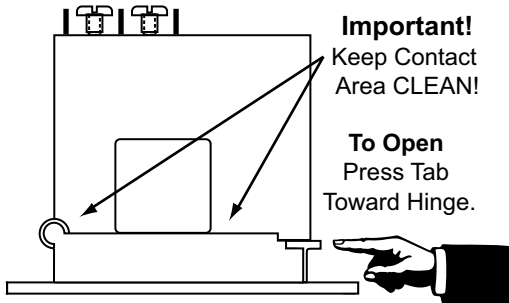

KEEP SPLIT-CORE SENSORS CLEAN.

Silicone grease is factory applied on the mating surfaces to prevent rust and improve performance. Be careful not to allow grit or dirt onto the grease in the contact area. Operation can be impaired if the mating surfaces do not have good contact. Check visually before closing.

OUTPUT WIRING

Connect control or monitoring wires to the sensor. Use 14 to 22 AWG copper wires rated at 75/90 °C. Terminals should be tightened to 5 to 7 in-lbs torque. Use copper conductors only. Be sure the output load or loop power requirements are met (see diagram).

Connection Notes:

- Captive screw terminals.
- 14 to 22 AWG solid or stranded.
- Observe Polarity
- See label for ranges & jumper positions

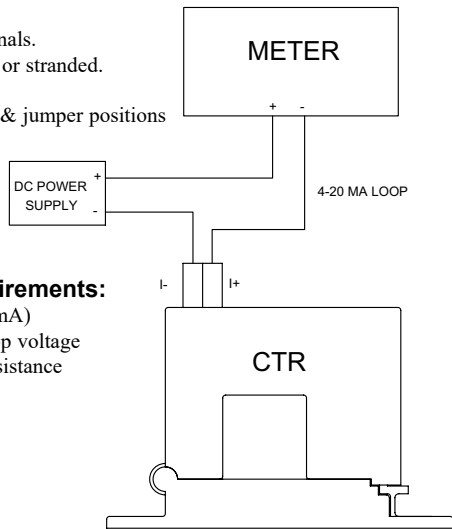

Loop Voltage Requirements:

$$V_L = 12V + (R_L \times 20 \text{ mA})$$

Where: V_L = Min. Loop voltage

R_L = Loop Resistance

RANGE SELECT

CTR series transducers feature field selectable ranges. The ranges are factory calibrated, eliminating time consuming and inaccurate field setting of zero or span.

1. Determine the normal operating amperage of your monitored circuit
2. Select the range that is equal to or slightly higher than the normal operating amperage.
3. Place the range jumper in the appropriate position.

TROUBLE SHOOTING

1. Sensor Has No Output

- A. Power supply is not properly sized. Check power supply voltage and current rating.
- B. Polarity is not properly matched. Check and correct wiring polarity.
- C. Split Core models: The core contact area may be dirty. Open the sensor and clean the contact area.

2. Output Signal Too Low

- A. The jumper may be set in a range that is too high for current being monitored. Move jumper to the correct range.
- B. Output load too high. Check output load, be sure that V_L does not exceed 40 VDC.
- C. Monitored current is below minimum required. Loop the monitored wire several times through the aperture until the "sensed" current rises above minimum. Sensed Amps = (Actual Amps) x (Number of Loops). Count loops on the inside of the aperture.

3. Output Signal Is Always At 4mA

- A. Monitored load is not AC or is not on. Check that the monitored load is AC and that it is actually on.

4. Output Signal Is Always At 20mA

- A. The jumper may be set in a range that is too low for current being monitored. Move jumper to the correct range.

RED LION CONTROLS TECHNICAL SUPPORT

If for any reason you have trouble operating, connecting, or simply have questions concerning your new unit, contact Red Lion's technical support.

Support: support.redlion.net

Website: www.redlion.net

Inside US: +1 (877) 432-9908

Outside US: +1 (717) 767-6511

ORDERING INFORMATION

MODEL NO.	DESCRIPTION	PART NUMBERS
CTR	50 A/4-20 mA, Split Case	CTR05000
	200 A/4-20 mA, Split Case	CTR20000

LIMITED WARRANTY

(a) Red Lion Controls Inc. (the "Company") warrants that all Products shall be free from defects in material and workmanship under normal use for the period of time provided in "Statement of Warranty Periods" (available at www.redlion.net) current at the time of shipment of the Products (the "Warranty Period"). **EXCEPT FOR THE ABOVE-STATED WARRANTY, COMPANY MAKES NO WARRANTY WHATSOEVER WITH RESPECT TO THE PRODUCTS, INCLUDING ANY (A) WARRANTY OF MERCHANTABILITY; (B) WARRANTY OF FITNESS FOR A PARTICULAR PURPOSE; OR (C) WARRANTY AGAINST INFRINGEMENT OF INTELLECTUAL PROPERTY RIGHTS OF A THIRD PARTY; WHETHER EXPRESS OR IMPLIED BY LAW, COURSE OF DEALING, COURSE OF PERFORMANCE, USAGE OF TRADE OR OTHERWISE.** Customer shall be responsible for determining that a Product is suitable for Customer's use and that such use complies with any applicable local, state or federal law.

(b) The Company shall not be liable for a breach of the warranty set forth in paragraph (a) if (i) the defect is a result of Customer's failure to store, install, commission or maintain the Product according to specifications; (ii) Customer alters or repairs such Product without the prior written consent of Company.

(c) Subject to paragraph (b), with respect to any such Product during the Warranty Period, Company shall, in its sole discretion, either (i) repair or replace the Product; or (ii) credit or refund the price of Product provided that, if Company so requests, Customer shall, at Company's expense, return such Product to Company.

(d) **THE REMEDIES SET FORTH IN PARAGRAPH (c) SHALL BE THE CUSTOMER'S SOLE AND EXCLUSIVE REMEDY AND COMPANY'S ENTIRE LIABILITY FOR ANY BREACH OF THE LIMITED WARRANTY SET FORTH IN PARAGRAPH (a).**