

# Serial EEPROM Series Standard EEPROM

## Plug & Play EEPROM

### BR34L02-W



#### ● General Description

BR34L02-W is 256 × 8 bit Electrically Erasable PROM (Based on Serial Presence Detect)

#### ● Features

- 256 × 8 bit architecture serial EEPROM
- Wide operating voltage range: 1.7V-5.5V
- Two-wire serial interface
- High reliability connection using Au pads and Au wires
- Self-Timed Erase and Write Cycle
- Page Write Function (16byte)
- Write Protect Mode
  - Write Protect 1 (Onetime Rom) : 00h-7Fh
  - Write Protect 2 (Hardwire WP PIN) : 00h-FFh
- Low Power consumption
  - Write ( at 5V ) :1.2mA (typ.)
  - Read ( at 5V ) :0.2mA(typ.)
  - Standby ( at 5V ) :0.1μA(typ.)
- DATA security
  - Write protect feature (WP pin)
  - Inhibit to WRITE at low Vcc
- High reliability fine pattern CMOS technology
- Rewriting possible up to 1,000,000 times
- Data retention: 40 years
- Noise reduction Filtered inputs in SCL / SDA
- Initial data FFh at all addresses

#### ● Packages W(Typ.) × D(Typ.) × H(Max.)

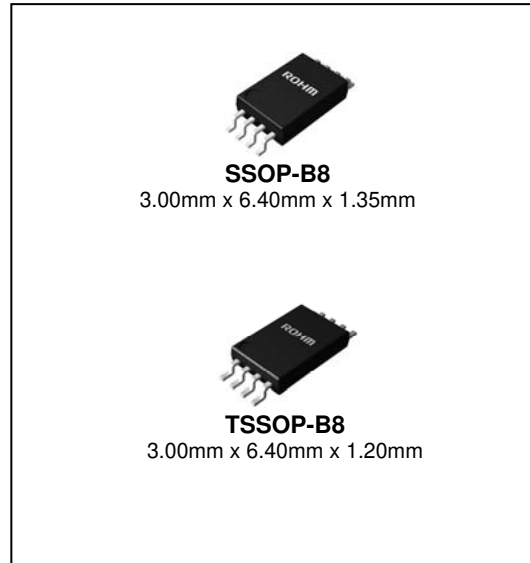

#### ● BR34L02-W

| Capacity | Bit format | Type      | Power Source Voltage | SSOP-B8 | TSSOP-B8 |
|----------|------------|-----------|----------------------|---------|----------|
| 2Kbit    | 256 x 8    | BR34L02-W | 1.7V to 5.5V         | ●       | ●        |

#### ● Absolute Maximum Ratings (Ta=25°C)

| Parameter             | Symbol | Rating          | Unit | Remarks                      |
|-----------------------|--------|-----------------|------|------------------------------|
| Supply Voltage        | Vcc    | -0.3 to +6.5    | V    |                              |
| Power Dissipation     | Pd     | 300 (SSOP-B8)   | mW   | Reduce by 3.0mW/°C over 25°C |
|                       |        | 330 (TSSOP-B8)  |      | Reduce by 3.3mW/°C over 25°C |
| Storage Temperature   | Tstg   | -65 to +125     | °C   |                              |
| Operating Temperature | Topr   | -40 to +85      | °C   |                              |
| Terminal Voltage      | -      | -0.3 to Vcc+0.3 | V    |                              |

**●Memory Cell Characteristics**( $T_a=25^{\circ}\text{C}$ ,  $V_{cc}=1.7\text{V}$  to  $5.5\text{V}$ )

| Parameter                         | Specification |      |      | Unit  |
|-----------------------------------|---------------|------|------|-------|
|                                   | Min.          | Typ. | Max. |       |
| Write / Erase Cycle <sup>*1</sup> | 1,000,000     | -    | -    | Times |
| Data Retention <sup>*1</sup>      | 40            | -    | -    | Years |

\*1: Not 100% TESTED

**●Recommended Operating Ratings**

| Parameter      | Symbol   | Rating        | Unit |
|----------------|----------|---------------|------|
| Supply Voltage | $V_{cc}$ | 1.7 to 5.5    | V    |
| Input Voltage  | $V_{IN}$ | 0 to $V_{cc}$ | V    |

**●Electrical Characteristics**
**DC**(Unless otherwise specified  $T_a=-40^{\circ}\text{C}$  to  $+85^{\circ}\text{C}$ ,  $V_{cc}=1.7\text{V}$  to  $5.5\text{V}$ )

| Parameter               | Symbol    | Specification |      |              | Unit          | Test Condition  |
|-------------------------|-----------|---------------|------|--------------|---------------|---|
|                         |           | Min.          | Typ. | Max.         |               |   |
| "H" Input Voltage 1     | $V_{IH1}$ | 0.7 $V_{cc}$  | -    | -            | V             | $2.5\text{V} \leq V_{cc} \leq 5.5\text{V}$  |
| "L" Input Voltage 1     | $V_{IL1}$ | -             | -    | 0.3 $V_{cc}$ | V             | $2.5\text{V} \leq V_{cc} \leq 5.5\text{V}$  |
| "H" Input Voltage 2     | $V_{IH2}$ | 0.8 $V_{cc}$  | -    | -            | V             | $1.7\text{V} \leq V_{cc} < 2.5\text{V}$   |
| "L" Input Voltage 2     | $V_{IL2}$ | -             | -    | 0.2 $V_{cc}$ | V             | $1.7\text{V} \leq V_{cc} < 2.5\text{V}$   |
| "L" Output Voltage 1    | $V_{OL1}$ | -             | -    | 0.4          | V             | $I_{OL}=3.0\text{mA}$ , $2.5\text{V} \leq V_{cc} \leq 5.5\text{V}$ (SDA)  |
| "L" Output Voltage 2    | $V_{OL2}$ | -             | -    | 0.2          | V             | $I_{OL}=0.7\text{mA}$ , $1.7\text{V} \leq V_{cc} < 2.5\text{V}$ (SDA)   |
| Input Leakage Current 1 | $I_{LI1}$ | -1            | -    | 1            | $\mu\text{A}$ | $V_{IN}=0\text{V}$ to $V_{cc}$ (A0,A1,A2,SCL)   |
| Input Leakage Current 2 | $I_{LI2}$ | -1            | -    | 15           | $\mu\text{A}$ | $V_{IN}=0\text{V}$ to $V_{cc}$ (WP)   |
| Output Leakage Current  | $I_{LO}$  | -1            | -    | 1            | $\mu\text{A}$ | $V_{OUT}=0\text{V}$ to $V_{cc}$ (SDA)   |
| Operating Current       | $I_{CC1}$ | -             | -    | 2.0          | mA            | $V_{cc}=5.5\text{V}$ , $f_{SCL}=400\text{kHz}$ , $t_{WR}=5\text{ms}$<br>Byte Write<br>Page Write<br>Write Protect |
|                         | $I_{CC2}$ | -             | -    | 0.5          | mA            | $V_{cc}=5.5\text{V}$ , $f_{SCL}=400\text{kHz}$<br>Random Read<br>Current Read<br>Sequential Read                  |
| Standby Current         | $I_{SB}$  | -             | -    | 2.0          | $\mu\text{A}$ | $V_{cc}=5.5\text{V}$ , SDA,SCL= $V_{cc}$<br>A0,A1,A2=GND, WP=GND  |

**AC**(Unless otherwise specified  $T_a=-40^{\circ}\text{C}$  to  $+85^{\circ}\text{C}$ ,  $V_{cc}=1.7\text{V}$  to  $5.5\text{V}$ )

| Parameter                           | Symbol        | FAST-MODE<br>$2.5\text{V} \leq V_{cc} \leq 5.5\text{V}$ |      |      | STANDARD-MODE<br>$1.7\text{V} \leq V_{cc} \leq 5.5\text{V}$ |      |      | Unit          |
|-------------------------------------|---------------|---|------|------|---|------|------|---------------|
|                                     |               | Min.  | Typ. | Max. | Min.  | Typ. | Max. |               |
| Clock Frequency                     | $f_{SCL}$     | -   | -    | 400  | -   | -    | 100  | kHz           |
| Data Clock High Period              | $t_{HIGH}$    | 0.6   | -    | -    | 4.0   | -    | -    | $\mu\text{s}$ |
| Data Clock Low Period               | $t_{LOW}$     | 1.2   | -    | -    | 4.7   | -    | -    | $\mu\text{s}$ |
| SDA and SCL Rise Time <sup>*1</sup> | $t_R$         | -   | -    | 0.3  | -   | -    | 1.0  | $\mu\text{s}$ |
| SDA and SCL Fall Time <sup>*1</sup> | $t_F$         | -   | -    | 0.3  | -   | -    | 0.3  | $\mu\text{s}$ |
| Start Condition Hold Time           | $t_{HD:STA}$  | 0.6   | -    | -    | 4.0   | -    | -    | $\mu\text{s}$ |
| Start Condition Setup Time          | $t_{SU:STA}$  | 0.6   | -    | -    | 4.7   | -    | -    | $\mu\text{s}$ |
| Input Data Hold Time                | $t_{HD:DAT}$  | 0   | -    | -    | 0   | -    | -    | ns            |
| Input Data Setup Time               | $t_{SU:DAT}$  | 50  | -    | -    | 50  | -    | -    | ns            |
| Output Data Delay Time              | $t_{PD}$      | 0.1   | -    | 0.9  | 0.2   | -    | 3.5  | $\mu\text{s}$ |
| Output Data Hold Time               | $t_{DH}$      | 0.1   | -    | -    | 0.2   | -    | -    | $\mu\text{s}$ |
| Stop Condition Setup Time           | $t_{SU:STO}$  | 0.6   | -    | -    | 4.7   | -    | -    | $\mu\text{s}$ |
| Bus Free Time                       | $t_{BUF}$     | 1.2   | -    | -    | 4.7   | -    | -    | $\mu\text{s}$ |
| Write Cycle Time                    | $t_{WR}$      | -   | -    | 5    | -   | -    | 5    | ms            |
| Noise Spike Width (SDA and SCL)     | $t_I$         | -   | -    | 0.1  | -   | -    | 0.1  | $\mu\text{s}$ |
| WP Hold Time                        | $t_{HD:WP}$   | 0   | -    | -    | 0   | -    | -    | ns            |
| WP Setup Time                       | $t_{SU:WP}$   | 0.1   | -    | -    | 0.1   | -    | -    | $\mu\text{s}$ |
| WP High Period                      | $t_{HIGH:WP}$ | 1.0   | -    | -    | 1.0   | -    | -    | $\mu\text{s}$ |

\*1 : Not 100% TESTED

### ■Fast / Standard Modes

Fast mode and Standard mode differ only in operation frequency. Operations performed at 100kHz are considered in "Standard-mode", while those conducted at 400kHz are in "Fast-mode".

Please note that these clock frequencies are maximum values. At lower power supply voltage it is difficult to operate at high speeds. The EEPROM can operate at 400kHz, between 2.5V and 5.5V, and at 100kHz from 1.7V-5.5V.

### ●Synchronous Data Timing

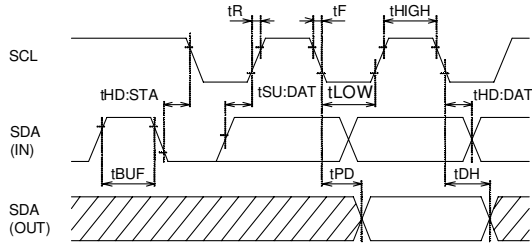

Figure 1-(a). Synchronous Data Timing

○SDA data is latched into the chip at the rising edge of SCL clock.

○Output data toggles at the falling edge of SCL clock.

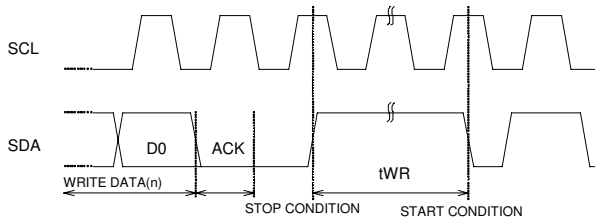

Figure 1-(c). Write Cycle Timing

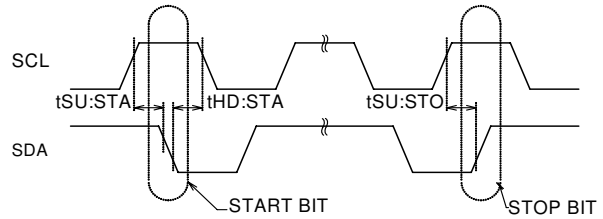

Figure 1-(b). Start/Stop Bit Timing

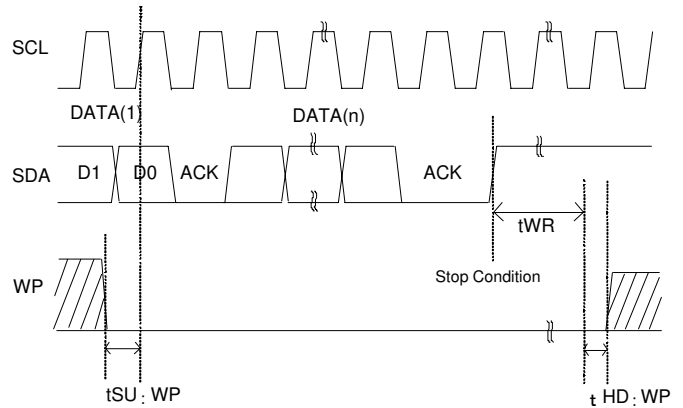

Figure 1-(d). WP Timing Of The Write Operation

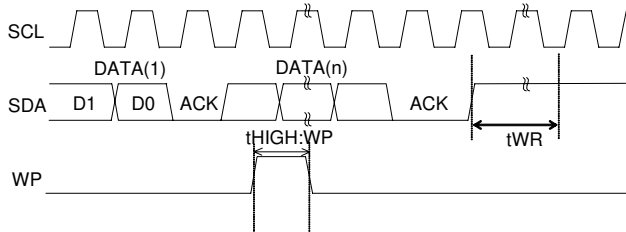
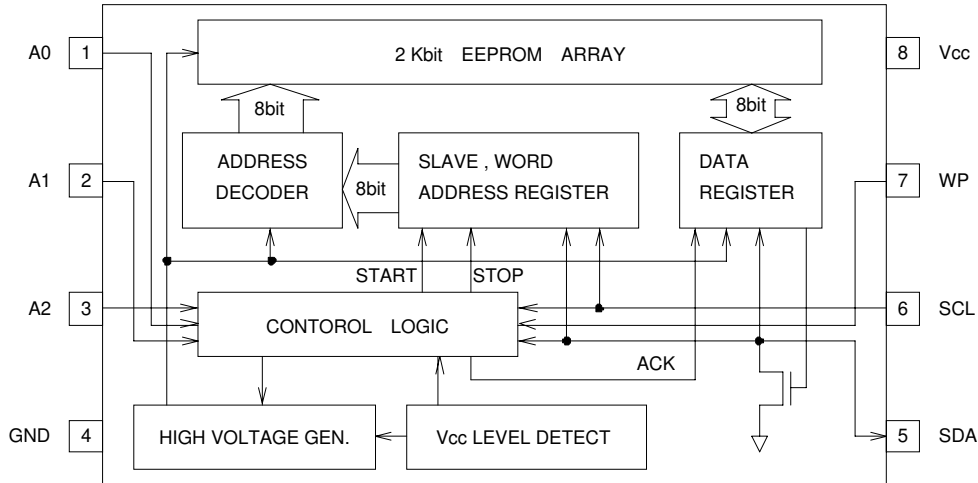

Figure 1-(e). WP Timing of The Write Cancel Operation

○For WRITE operation, WP must be "Low" from the rising edge of the clock (which takes in D0 of first byte) until the end of tWR. (See Figure 1-(d) ) During this period, WRITE operation can be canceled by setting WP "High". (See Figure 1-(e))

○When WP is set to "High" during tWR, WRITE operation is immediately ceased, making the data unreliable. It must then be re-written.

### ●Block Diagram



### ●Pin Configuration

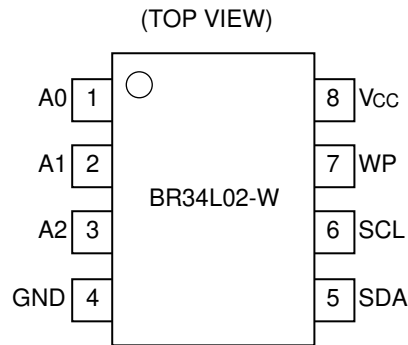

### ●Pin Descriptions

| Pin Name | Input/Output | Functions   |
|----------|--------------|---|
| Vcc      | -            | Power Supply  |
| GND      | -            | Ground 0V   |
| A0,A1,A2 | IN           | Slave Address Set.  |
| SCL      | IN           | Serial Clock Input  |
| SDA      | IN / OUT     | Slave and Word Address, Serial Data Input, Serial Data Output <sup>*1</sup> |
| WP       | IN           | Write Protect Input <sup>*2</sup>   |

<sup>\*1</sup> Open drain output requires a pull-up resistor.

<sup>\*2</sup> WP Pin has a Pull-Down resistor. Please leave unconnected or connect to GND when not in use.

● Typical Performance Curves

The following characteristic data are typ. value.

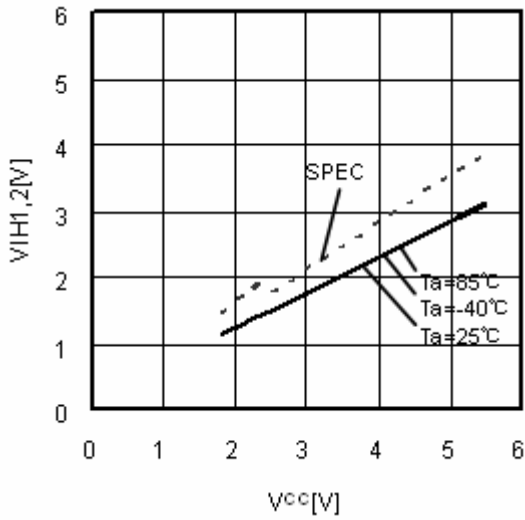

Figure 2. "H" Input Voltage  $V_{IH1,2}$   
(A0,A1,A2,SCL,SDA,WP)

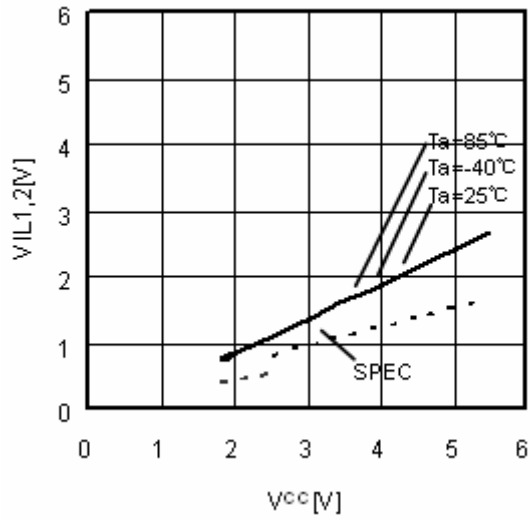

Figure 3. "L" Input Voltage  $V_{IL1,2}$   
(A0,A1,A2,SCL,SDA,WP)

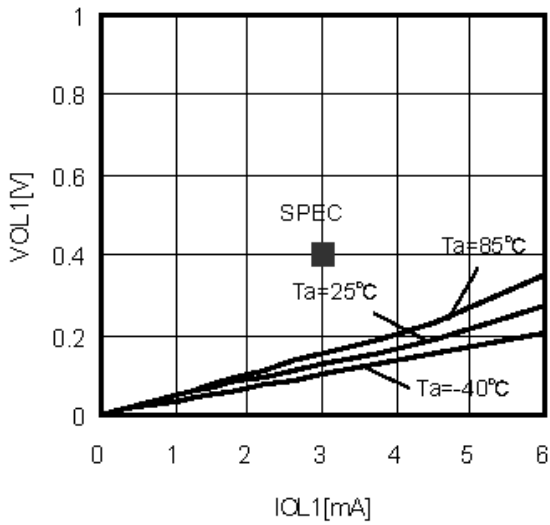

Figure 4. "L" Output Voltage  $V_{OL1}$ - $I_{OL1}$  ( $V_{cc}=2.5V$ )

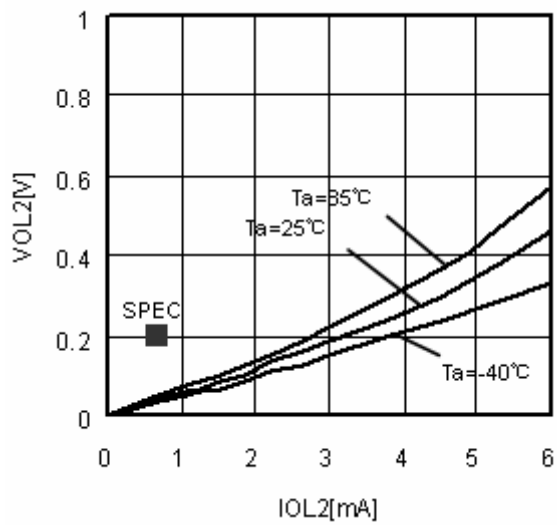

Figure 5. "L" Output Voltage  $V_{OL2}$ - $I_{OL2}$  ( $V_{cc}=1.7V$ )

● Typical Performance Curves - Continued

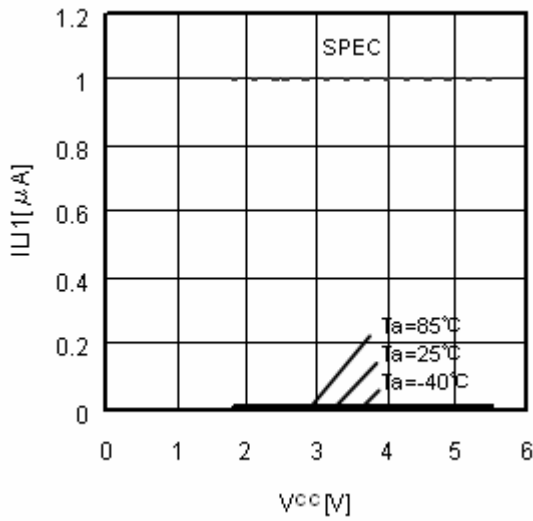

Figure 6. Input Leakage Current ILI1 (A0,A1,A2,SCL,SDA)

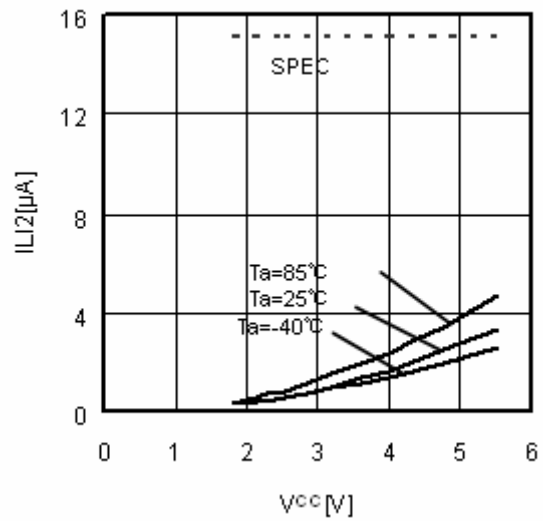

Figure 7. Input Leakage Current ILI2 (WP)

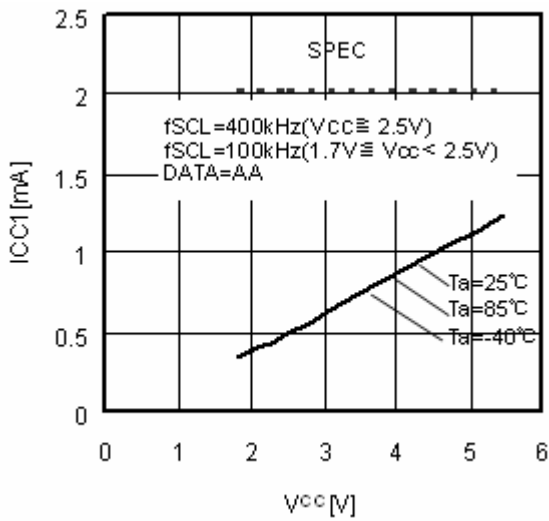

Figure 8. Write Operating Current ICC1 (fSCL=100kHz,400kHz)

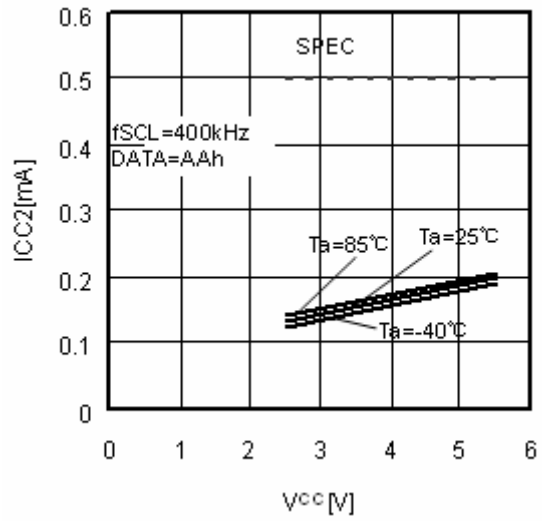

Figure 9. Read Operating Current ICC2 (fSCL=400kHz)

● Typical Performance Curves - Continued

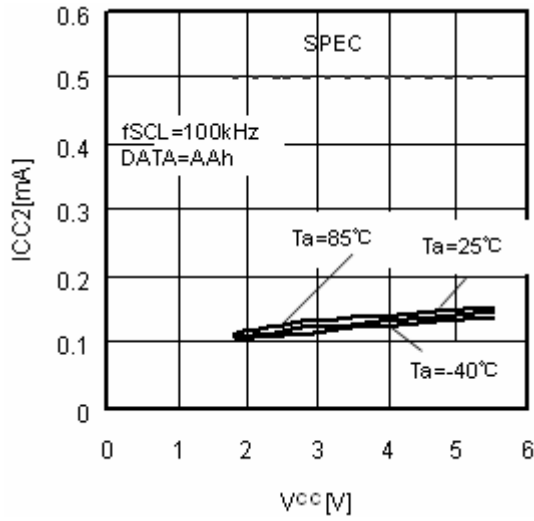

Figure 10. Read Operating Current ICC2 (fSCL=100kHz)

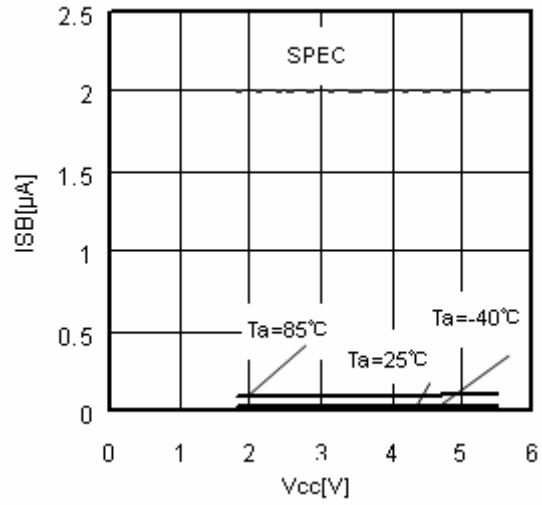

Figure 11. Standby Current ISB

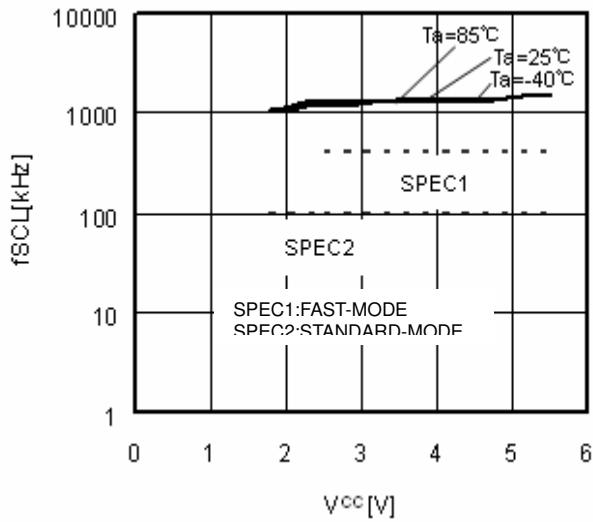

Figure 12. Clock Frequency fSCL

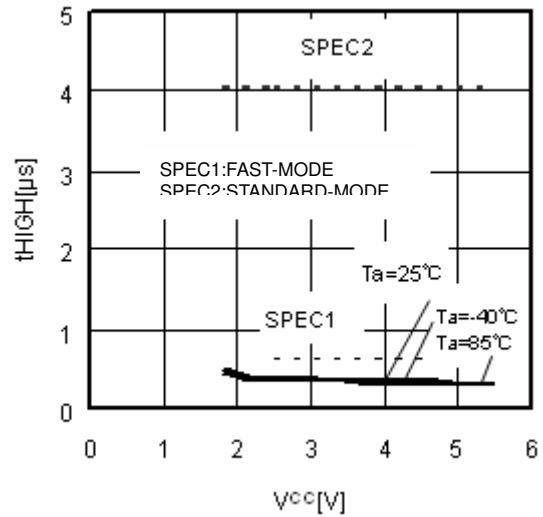

Figure 13. Data Clock High Period tHigh

● Typical Performance Curves - Continued

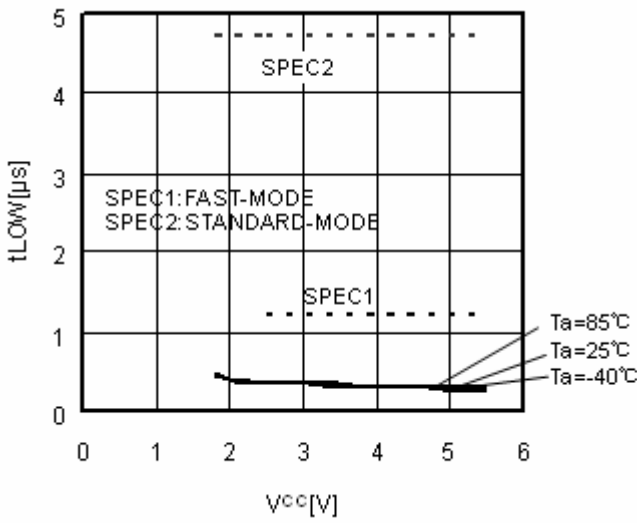

Figure 14. Data Clock Low Period  $t_{LOW}$

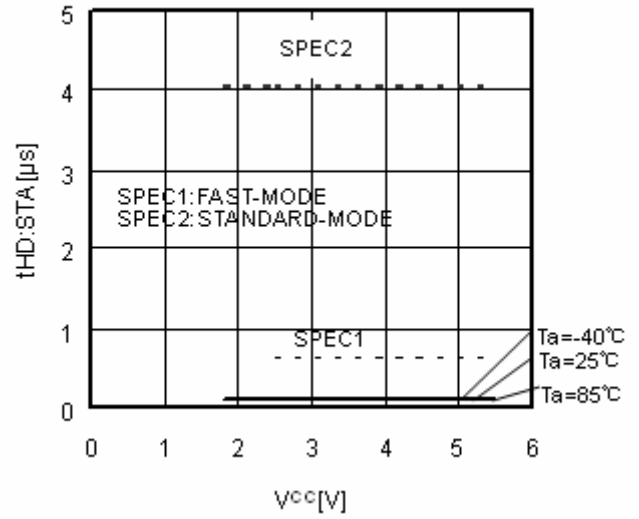

Figure 15. Start Condition Hold Time  $t_{HD:STA}$

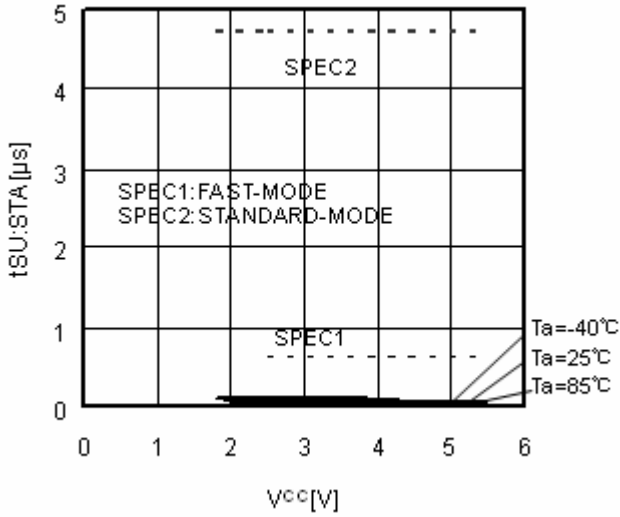

Figure 16. Start Condition Setup Time  $t_{SU:STA}$

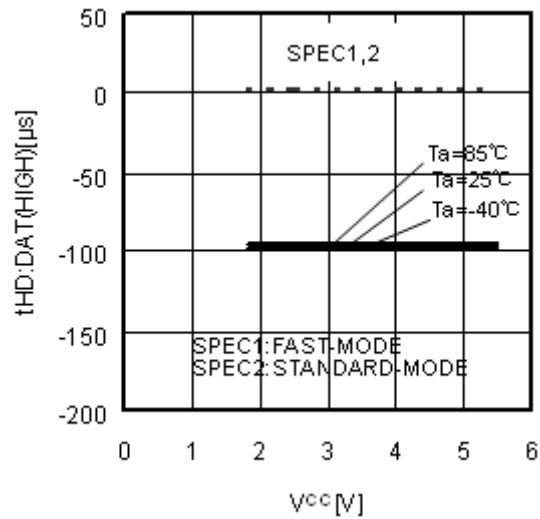

Figure 17. Input Data Hold Time  $t_{HD:DAT}$  (High)



● Typical Performance Curves - Continued

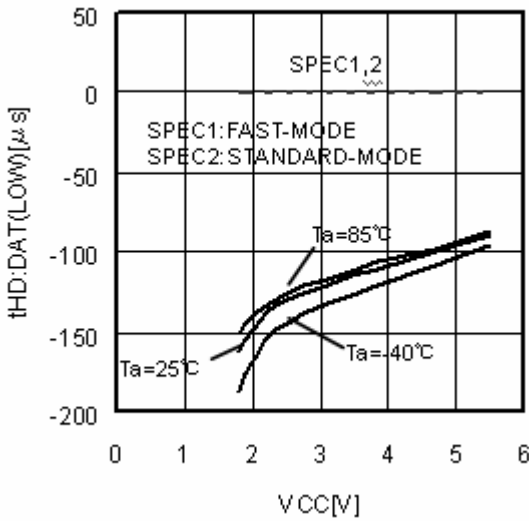

Figure 18. Input Data Hold Time  
tHD:DAT(LOW)

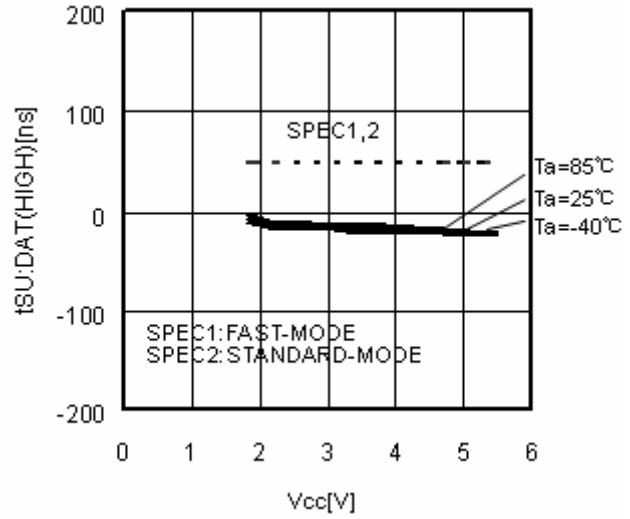

Figure 19. Input Data Setup Time  
tSU:DAT(High)

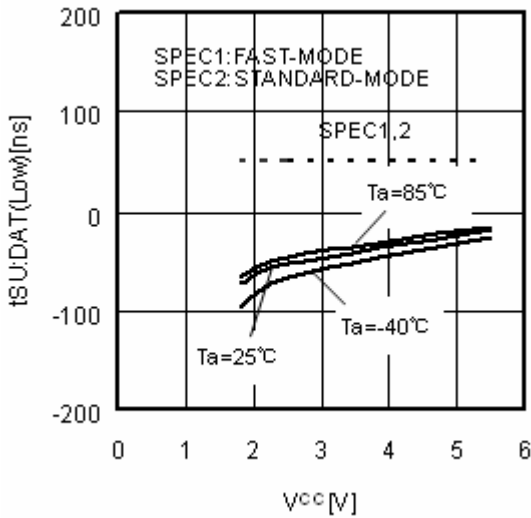

Figure 20. Input Data Setup Time  
tSU:DAT(Low)

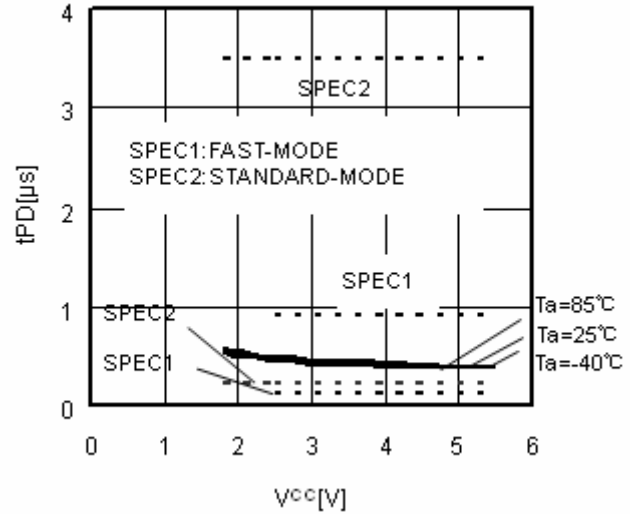

Figure 21. Output Data Delay Time  
tPD

● Typical Performance Curves - Continued

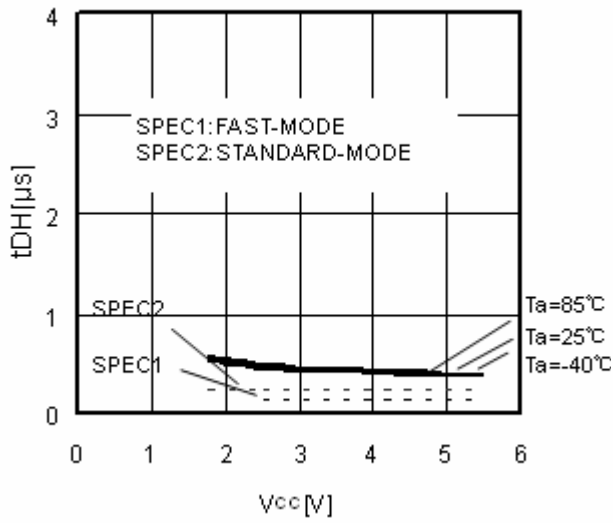

Figure 22. Output Data Hold Time tDH

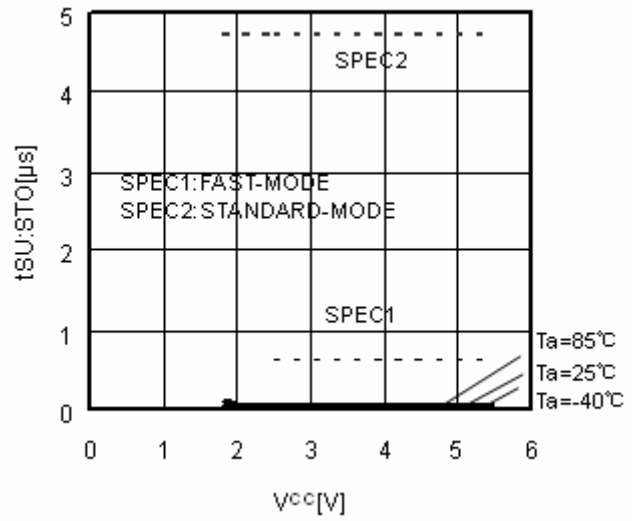

Figure 23. Stop Condition Setup Time tSU:STO

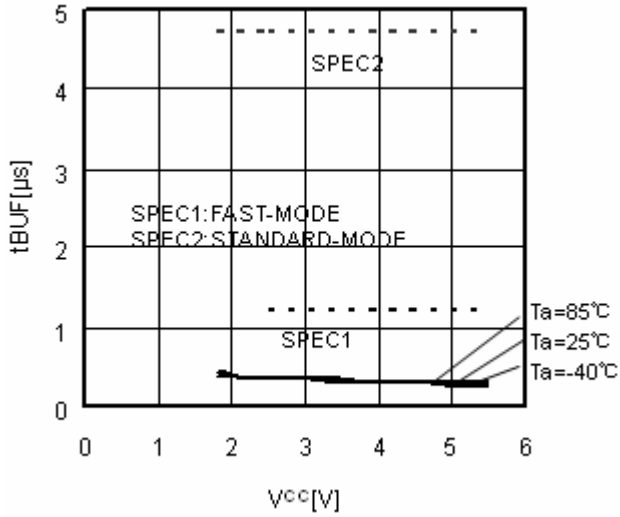

Figure 24. Bus Free Time tBUF

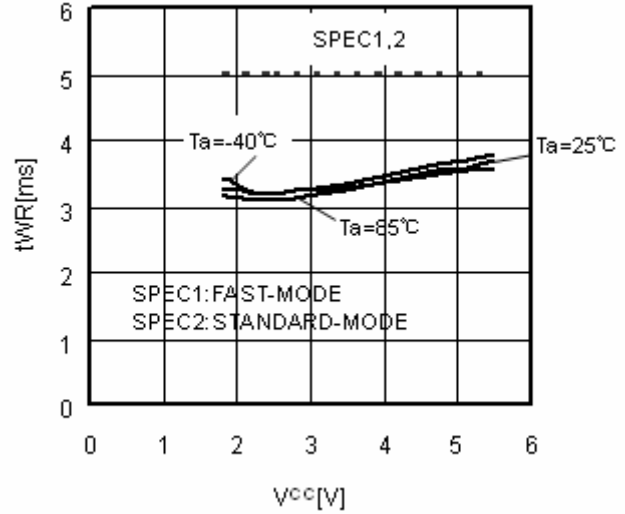

Figure 25. Write Cycle Time tWR

● Typical Performance Curves - Continued

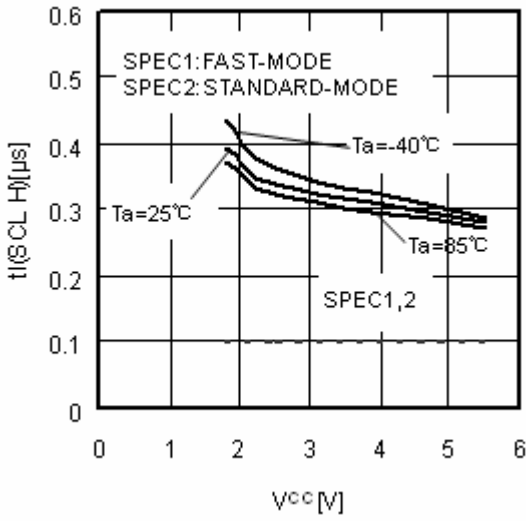

Figure 26. Noise Spike Width  $t_I(\text{SCL H})$

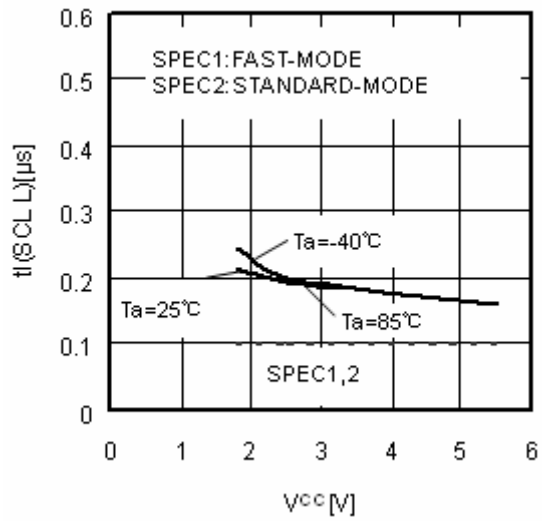

Figure 27. Noise Spike Width  $t_I(\text{SCL L})$

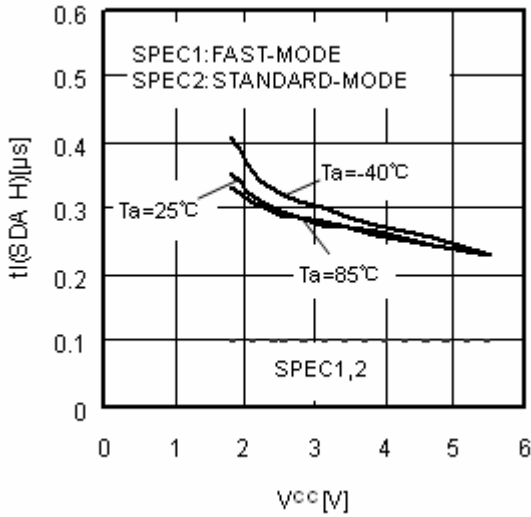

Figure 28. Noise Spike Width  $t_I(\text{SDA H})$

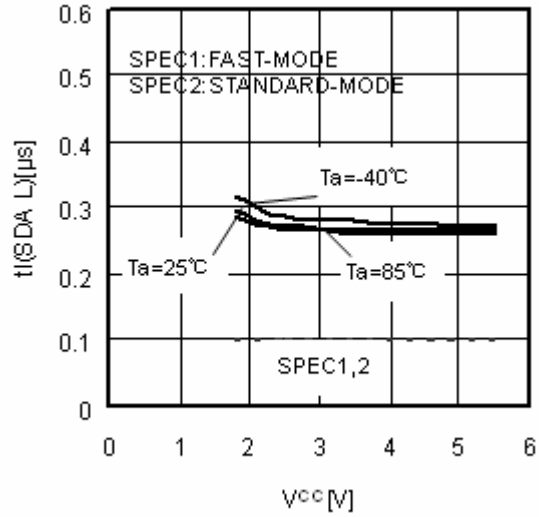

Figure 29. Noise Spike Width  $t_I(\text{SDA L})$

● Typical Performance Curves - Continued

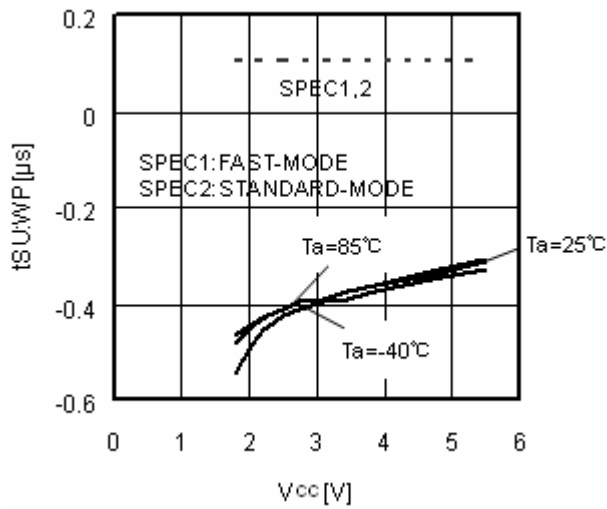

Figure 30. WP Setup Time  
 $t_{SU:WP}$

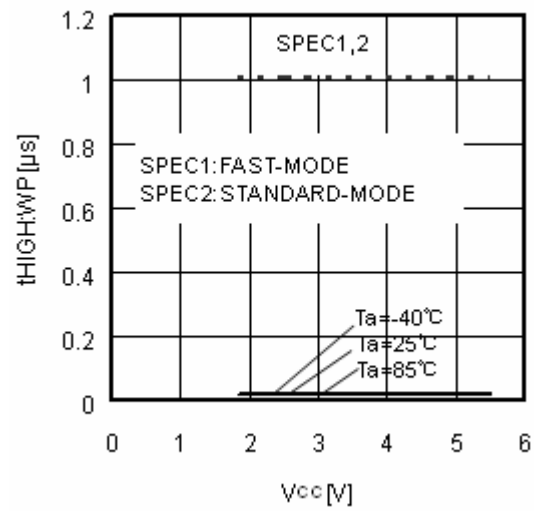

Figure 31. WP High Period  
 $t_{High:WP}$

## ●Data transfer on the I<sup>2</sup>C BUS

### ○Data transfer on the I<sup>2</sup>C BUS

The BUS is considered to be busy after the START condition and free a certain time after the STOP condition.

Every SDA byte must be 8-bits long and requires an ACKNOWLEDGE signal after each byte. The devices have Master and Slave configurations. The Master device initiates and ends data transfer on the BUS and generates the clock signals in order to permit transfer.

The EEPROM in a slave configuration is controlled by a unique address. Devices transmitting data are referred to as the Transmitter. The devices receiving the data are called Receiver.

### ○START Condition (Recognition of the START bit)

- All commands are proceeded by the start condition, which is a High to Low transition of SDA when SCL is High.
- The device continuously monitors the SDA and SCL lines for the start condition and will not respond to any command until this condition has been met. (See Figure 1-(b) START/STOP Bit Timing)

### ○STOP Condition (Recognition of STOP bit)

- All communications must be terminated by a stop condition, which is a Low to High transition of SDA when SCL is High. (See Figure 1-(b) START/STOP Bit Timing)

### ○Acknowledge

- Acknowledge is a software used to indicate successful data transfers. The Transmitter device will release the BUS after transmitting eight bits. When inputting the slave address during write or read operation, the Transmitter is the  $\mu$ -COM. When outputting the data during read operation, the Transmitter is the EEPROM.
- During the ninth clock cycle the Receiver will pull the SDA line Low to verify that the eight bits of data have been received. (When inputting the slave address during write or read operation, EEPROM is the receiver. When outputting the data during read operation the receiver is the  $\mu$ -COM.)
- The device will respond with an Acknowledge after recognition of a START condition and its slave address (8bit).
- In WRITE mode, the device will respond with an Acknowledge after the receipt of each subsequent 8-bit word (word address and write data).
- In READ mode, the device will transmit eight bits of data, release the SDA line, and monitor the line for an Acknowledge.
- If an Acknowledge is detected and no STOP condition is generated by the Master, the device will continue to transmit the data. If an Acknowledge is not detected, the device will terminate further data transmissions and await a STOP condition before returning to standby mode.

### ○Device Addressing

- Following a START condition, the Master outputs the Slave address to be accessed. The most significant four bits of the slave address are the "device type identifier." For this EEPROM it is "1010." (For WP register access this code is "0110".)
- The next three bits identify the specified device on the BUS (device address). The device address is defined by the state of the A0,A1 and A2 input pins. This IC works only when the device address input from the SDA pin corresponds to the status of the A0,A1 and A2 input pins. Using this address scheme allows up to eight devices to be connected to the BUS. The last bit of the stream (R/W···READ/WRITE) determines the operation to be performed.

R/W=0                      WRITE (including word address input of Random Read)  
R/W=1                      READ

| Device Type | Device Address |    |    | Read Write Mode | Access Area                      |
|-------------|----------------|----|----|-----------------|----------------------------------|
| 1010        | A2             | A1 | A0 | R/W             | Access to Memory                 |
| 0110        | A2             | A1 | A0 | R/W             | Access to Write Protect Register |

### ○Write Protect command

The Write Protect command cancels any write commands that access addresses 00 to 7Fh.

The Write Protect Register can be written to once (One time Rom).

Once this command is executed, the data is protected forever.

### ○Write Protect Pin (WP)

When the WP pin set to Vcc (H level), write protect is set for 256 words (all addresses). WP pin set to GND (L level) enables writing of 256 words (all addresses).

If permanent protection is implemented by the Write Protect command, writing is prohibited in the the lower half area (addresses 00 to 7Fh) regardless of the WP pin status.

The WP pin has a pulldown resistor. Please leave unconnected or connect to GND when not in use.

## ●Command

### ○Write Cycle

During WRITE CYCLE operation data is written in the EEPROM. The Byte Write Cycle is used to write only one byte. In the case of writing continuous data consisting of more than one byte, Page Write is used. The maximum bytes that can be written at one time are 16 bytes.

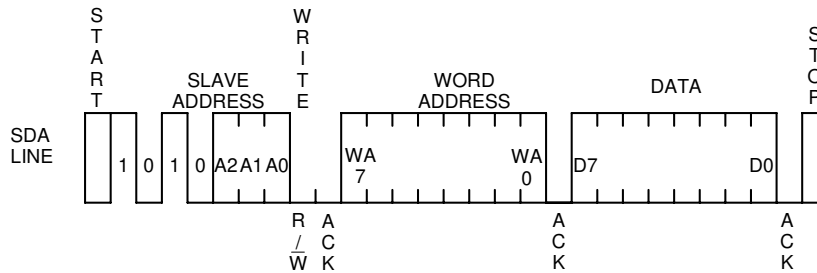

Figure 32. Byte Write Cycle Timing

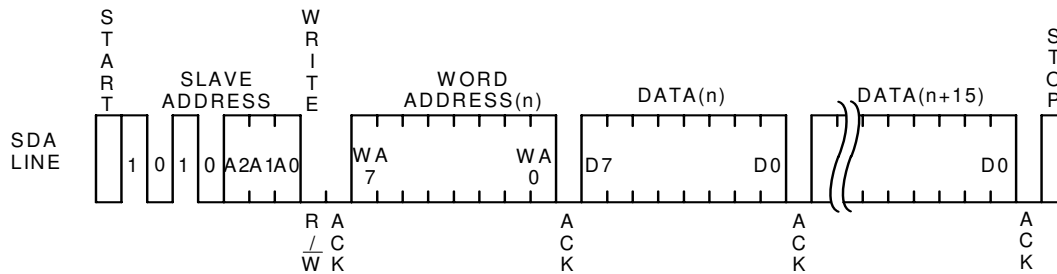

Figure 33. Page Write Cycle Timing

- With this command the data is programmed into the indicated word address.
- When the Master generates a STOP condition, the device begins the internal write cycle to the nonvolatile memory array. This device is capable of sixteen-byte Page Write operations. Once programming is started no commands are accepted for  $t_{WR}$  (5ms max.). If the Master transmits more than sixteen words prior to generating the STOP condition, the address counter will “roll over” and the previously transmitted data will be overwritten. When two or more byte of data are input, the four low order address bits are internally incremented by one after the receipt of each word, while the four higher order bits of the address (WA7 to WA4) remain constant.

### Read Cycle

During Read Cycle operation data is read from the EEPROM. The Read Cycle is composed of Random Read Cycle and Current Read Cycle. The Random Read Cycle reads the data in the indicated address.

The Current Read Cycle reads the data in the internally indicated address and verifies the data immediately after the Write Operation. The Sequential Read operation can be performed with both Current Read and Random Read. With the Sequential Read Cycle it is possible to continuously read the next data.

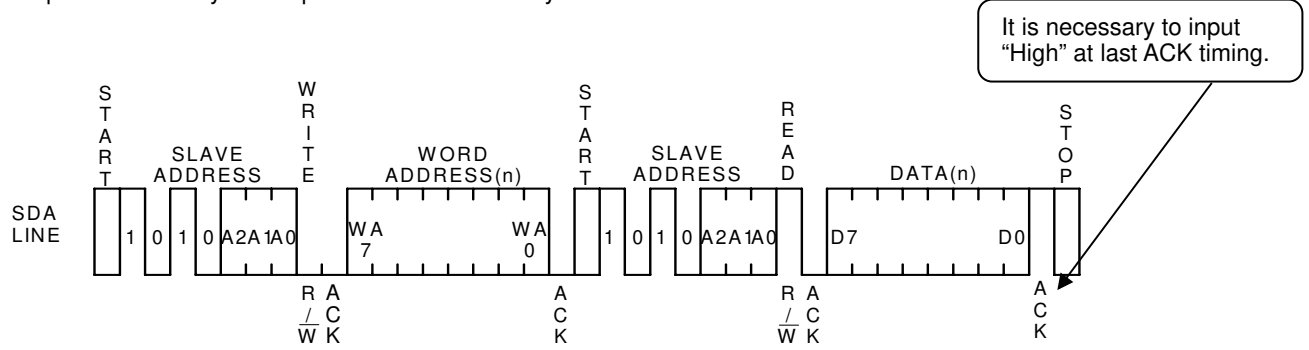

Figure 34. Random Read Cycle Timing

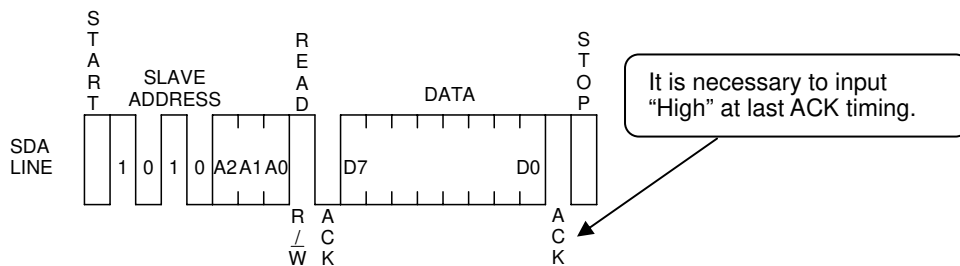

Figure 35. Current Read Cycle Timing

- Random Read operation allows the Master to access any memory location indicated by word address.
- In cases where the previous operation is Random or Current Read (which includes Sequential Read), the internal address counter is increased by one from the last accessed address (n). Thus Current Read outputs the data of the next word address (n+1).
- If an Acknowledge is detected and no STOP condition is generated by the Master ( $\mu$ -COM), the device will continue to transmit data. (It can transmit all data (2kbit 256word))
- If an Acknowledge is not detected, the device will terminate further data transmissions and await a STOP condition before returning to standby mode.
- If an Acknowledge is detected with the "Low" level (not "High" level), the command will become Sequential Read, and the next data will be transmitted. Therefore, the Read command is not terminated. In order to terminate Read input Acknowledge with "High" always, then input a STOP condition.

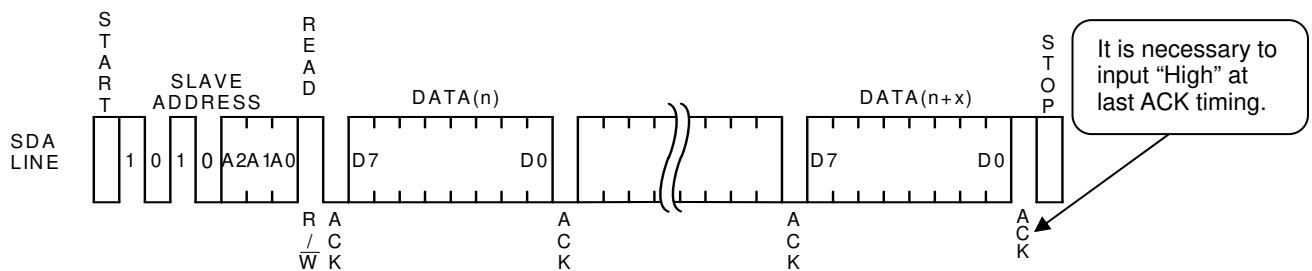

Figure 36. Sequential Read Cycle Timing (With Current Read)

### ● Software Reset

Execute software reset in the event that the device is in an unexpected state after power up and/or the command input needs to be reset. Below are three types (Figure 37-(a), (b), (c)) of software reset:

- During dummy clock, release the SDA BUS (tied to Vcc by a pull-up resistor).
- During this time the device may pull the SDA line Low for Acknowledge or the outputting of read data.
- If the Master sets the SDA line to High, it will conflict with the device output Low, which can cause current overload and result in instantaneous power down, which may damage the device.

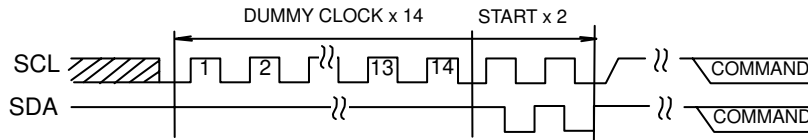

Figure 37-(a). DUMMY CLOCK x 14 + START+START

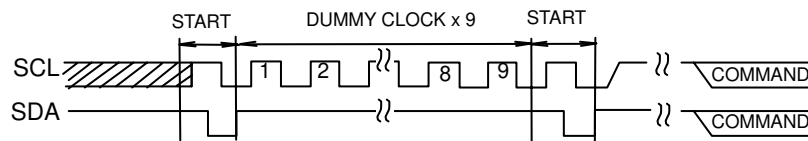

Figure 37-(b). START + DUMMY CLOCK x 9 + START

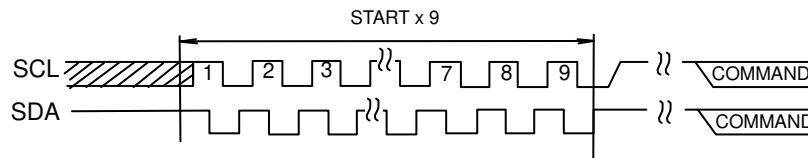

Figure 37-(c). START x 9

\* COMMAND starts with start condition.

### ● Acknowledge polling

Since the IC ignores all input commands during the internal write cycle, no ACK signal will be returned.

When the Master sends the next command after the Write command, if the device returns an ACK signal it means that the program is completed. No ACK signal indicates that the device is still busy.

Using Acknowledge polling decreases the waiting time by  $t_{WR}=5\text{ms}$ .

When operating Write or Current Read after Write, first transmit the Slave address ( $R/\bar{W}$  is "High" or "Low"). After the device returns the ACK signal continue word address input or data output.

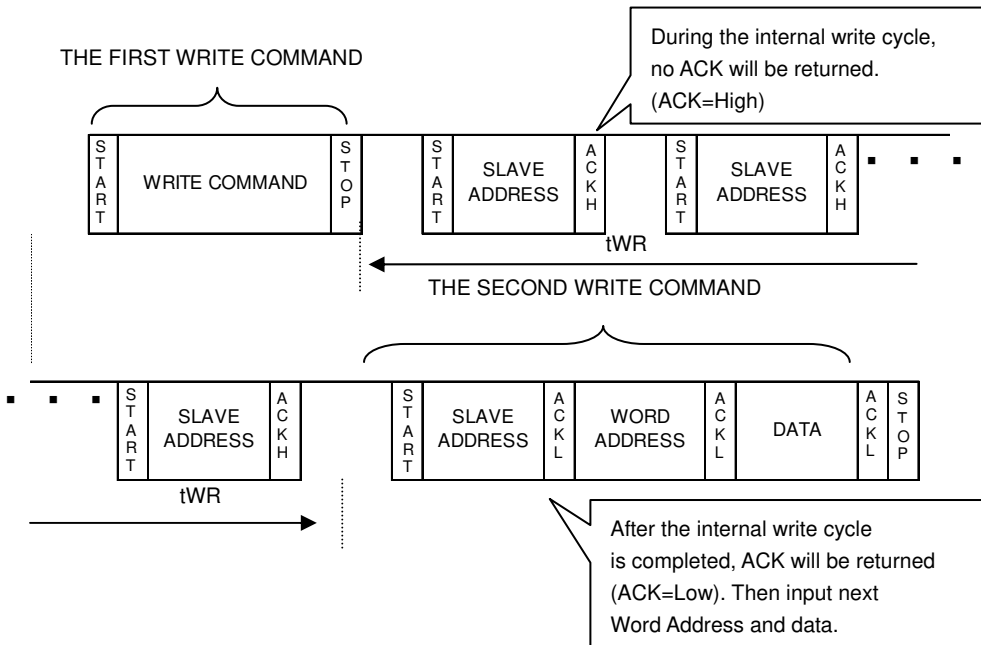

Figure 38. Successive Write Operation By Acknowledge Polling



### ● WP effective timing

WP is normally fixed at "H" or "L". However, in case WP needs to be controlled in order to cancel the Write command, pay attention to "WP effective timing" as follows:

The Write command is canceled by setting WP to "H" within the WP cancellation effective period.

The period from the START condition to the rising edge of the clock (which takes in the data DO - the first byte of the Page Write data) is the 'invalid cancellation period'. WP input is considered inconsequential during this period. The setup time for the rising edge of the SCL, which takes in DO, must be more than 100ns.

The period from the rising edge of SCL (which takes in the data D0) to the end of internal write cycle ( $t_{WR}$ ) is the 'effective cancellation period'. When WP is set to "H" during  $t_{WR}$ , Write operation is stopped, making it necessary to rewrite the data.

It is not necessary to wait for  $t_{WR}$  (5ms max.) after stopping the Write command by WP because the device is in standby mode.

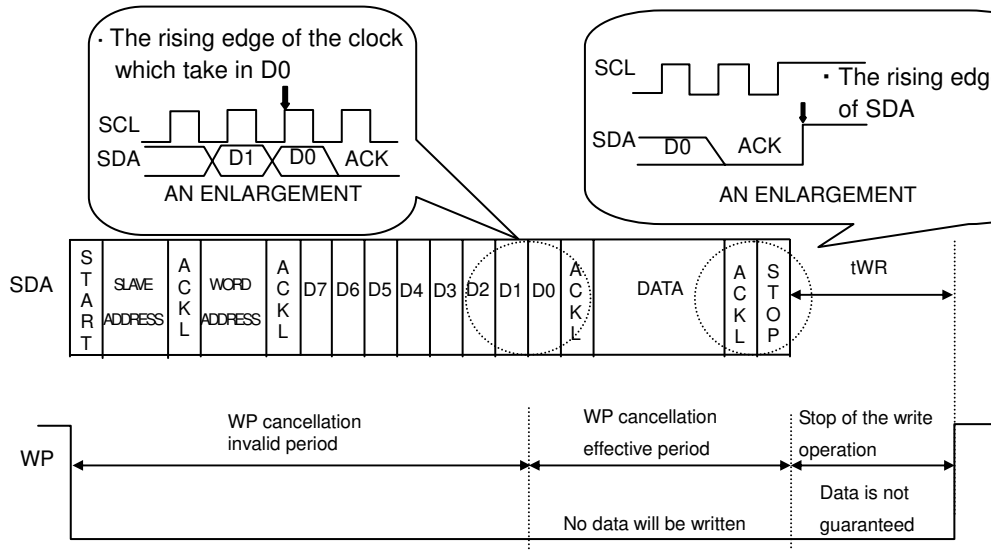

Figure 39. WP effective timing

### ● Command cancellation from the START and STOP conditions

Command input is canceled by successive inputs of START and STOP conditions. (Refer to Figure 40)

However, during ACK or data output, the device may set the SDA line to Low, making operation of the START and STOP conditions impossible, and thus preventing reset. In this case execute reset by software. (Refer to Figure 37)

The internal address counter will not be determined when operating the Cancel command by the START and STOP conditions during Random, Sequential or Current Read. Operate a Random Read in this case.

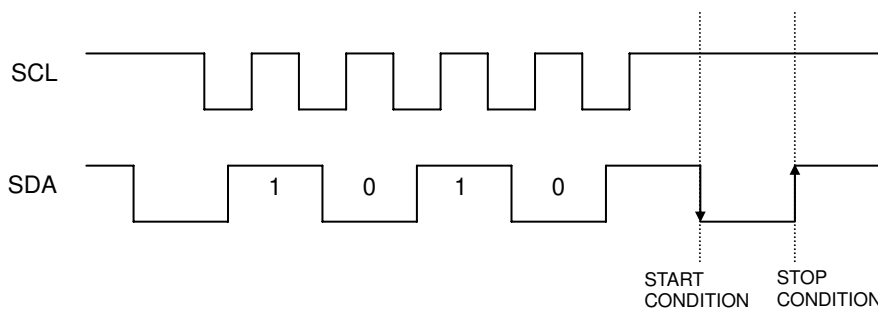

Figure 40. Command cancellation by the START and STOP conditions during input of the Slave Address

## ● I/O Circuit

### ○ SDA Pin Pull-up Resistor

A pull-up resistor is required because SDA is an NMOS open drain. Determine the resistor value of (RPU) by considering the  $V_{IL}$  and  $I_L$ , and  $V_{OL}-I_{OL}$  characteristics. If a large RPU is chosen, the clock frequency needs to be slow. A smaller RPU will result in a larger operating current.

### ○ Maximum RPU

The maximum of RPU can be determined by the following factors.

① The SDA rise time determined by RPU and the capacitance of the BUS line (CBUS) must be less than  $t_R$ .

In addition, all other timings must be kept within the AC specifications.

② When the SDA BUS is High, the voltage A at the SDA BUS is determined from the total input leakage ( $I_L$ ) of all devices connected to the BUS. RPU must be higher than the input High level of the microcontroller and the device, including a noise margin of 0.2Vcc.

$$V_{CC} - I_L R_{PU} - 0.2V_{CC} \geq V_{IH}$$

$$\therefore R_{PU} \leq \frac{0.8V_{CC} - V_{IH}}{I_L}$$

Examples: When  $V_{CC} = 3V$ ,  $I_L = 10\mu A$ ,  $V_{IH} = 0.7V_{CC}$   
According to ②

$$R_{PU} \leq \frac{0.8 \times 3 - 0.7 \times 3}{10 \times 10^{-6}}$$

$$\leq 300 \text{ [k}\Omega\text{]}$$

### ○ Minimum RPU

The minimum value of RPU is determined by following factors.

① Meets the condition that  $V_{OLMAX} = 0.4V$ ,  $I_{OLMAX} = 3mA$  when the output is Low.

$$\frac{V_{CC} - V_{OL}}{R_{PU}} \leq I_{OL}$$

$$\therefore R_{PU} \geq \frac{V_{CC} - V_{OL}}{I_{OL}}$$

②  $V_{OLMAX} = 0.4V$  must be lower than the input Low level of the microcontroller and the EEPROM including the recommended noise margin of 0.1Vcc.

$$V_{OLMAX} \leq V_{IL} - 0.1V_{CC}$$

$$R_{PU} \geq \frac{3 - 0.4}{3 \times 10^{-3}}$$

$$\geq 867 \text{ [}\Omega\text{]}$$

and  $V_{OL} = 0.4 \text{ [V]}$   
 $V_{IL} = 0.3 \times 3$   
 $= 0.9 \text{ [V]}$

so that condition ② is met

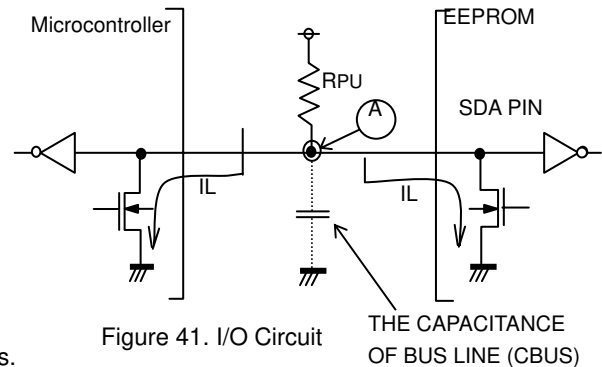

Figure 41. I/O Circuit

THE CAPACITANCE OF BUS LINE (CBUS)

### ○ SCL Pin Pull-up Resistor

When SCL is controlled by the CMOS output the pull-up resistor at SCL is not required.

However, should SCL be set to Hi-Z, connection of a pull-up resistor between SCL and Vcc is recommended. Several k $\Omega$  are recommended for the pull-up resistor in order to drive the output port of the microcontroller.

## ● A0, A1, A2, WP Pin connections

### ○ Device Address Pin (A0, A1, A2) connections

The status of the device address pins is compared with the device address sent by the Master. One of the devices that is connected to the identical BUS is selected. Pull up or down these pins or connect them to Vcc or GND. Pins that are not used as device address (N.C.Pins) may be High, Low, or Hi-Z.

### ○ OWP Pin connection

The WP input allows or prohibits write operations. When WP is High, only Read is available and Write to all address is prohibited. Both Read and Write are available when WP is Low.

In the event that the device is used as a ROM, it is recommended that the WP input be pulled up or connected to Vcc. When both READ and WRITE are operated, the WP input must be pulled down or connected to GND or controlled.

●Microcontroller connection

○Concerning Rs

The open drain interface is recommended for the SDA port in the I<sup>2</sup>C BUS. However, if the Tri-state CMOS interface is applied to SDA, insert a series resistor (Rs) between the SDA pin of the device and the pull up resistor RPU is recommended, since it will serve to limit the current between the PMOS of the microcontroller, and the NMOS of the EEPROM. Rs also protects the SDA pin from surges. Therefore, Rs is able to be used though open drain in/out of the SDA port.

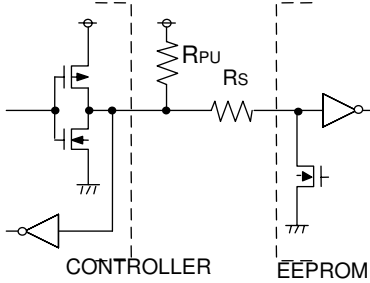

Figure 42. I/O Circuit

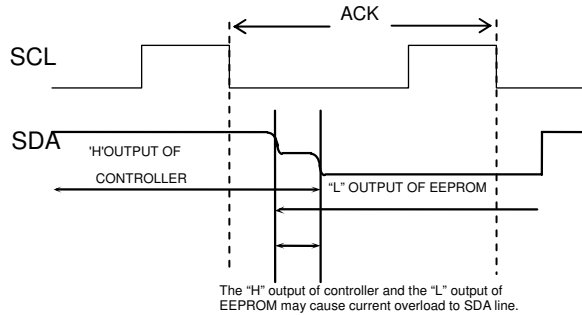

Figure 43. Input/Output Collision Timing

○Rs Maximum

The maximum value of Rs is determined by following factors.

- ①SDA rise time determined by RPU and the capacitance value of the BUS line (CBUS) of SDA must be less than tR. In addition, the other timings must be within the timing conditions of the AC.
- ②When the output from SDA is Low, the voltage of the BUS at  $\text{ⓐ}$  is determined by RPU, and Rs must be lower than the input Low level of the microcontroller, including recommended noise margin (0.1Vcc).

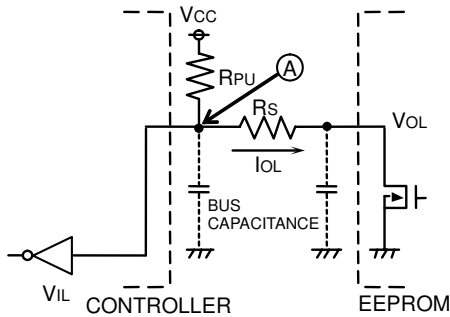

Figure 44. I/O Circuit

$$\frac{(V_{CC}-V_{OL}) \times R_S}{R_{PU}+R_S} + V_{OL} + 0.1V_{CC} \leq V_{IL}$$

$$\therefore R_S \leq \frac{V_{IL}-V_{OL}-0.1V_{CC}}{1.1V_{CC}-V_{IL}} \times R_{PU}$$

Examples : When VCC=3V VIL=0.3VCC VOL=0.4V RPU=20kΩ

$$\text{According to ② } R_S \leq \frac{0.3 \times 3 - 0.4 - 0.1 \times 3}{1.1 \times 3 - 0.3 \times 3} \times 20 \times 10^3 \leq 1.67 \text{ [k}\Omega\text{]}$$

○Rs Minimum

The minimum value of Rs is determined by the current overload during BUS conflict. Current overload may cause noises in the power line and instantaneous power down.

The following conditions must be met, where "I" is the maximum permissible current, which depends on the Vcc line impedance as well as other factors. "I" current must be less than 10mA for EEPROM.

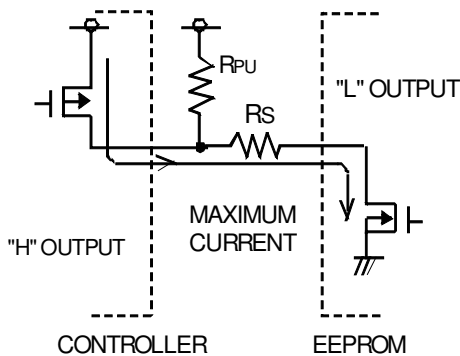

$$\frac{V_{CC}}{R_S} \leq I$$

$$\therefore R_S \geq \frac{V_{CC}}{I}$$

Examples: When VCC=3V, I=10mA

$$R_S \geq \frac{3}{10 \times 10^{-3}} \geq 300 \text{ [}\Omega\text{]}$$

Figure 45. I/O Circuit

### ● I<sup>2</sup>C BUS Input / Output equivalent circuits

OInput (A0,A2,SCL)

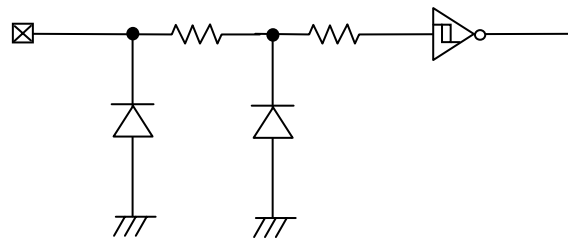

Figure 46. Input Pin Circuit

OInput / Output (SDA)

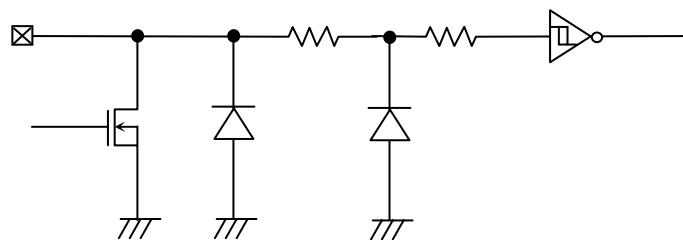

Figure 47. Input / Output Pin Circuit

OInput (A1)

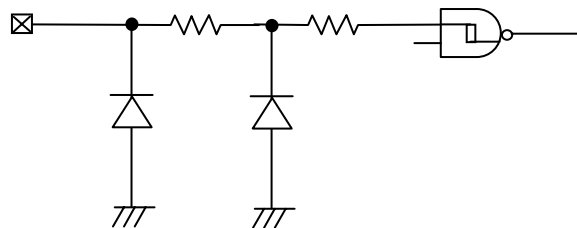

Figure 48. Input Pin Circuit

OInput (WP)

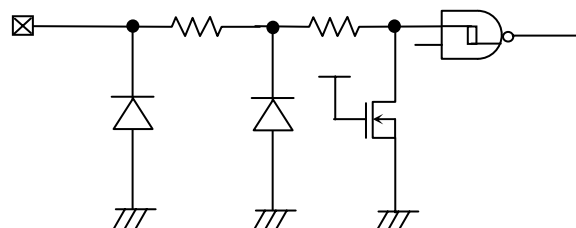

Figure 49. Input Pin Circuit

### ● Power Supply Notes

Vcc increases through the low voltage region where the internal circuit of IC and the microcontroller are unstable. In order to prevent malfunction, the IC has P.O.R and LVCC functionality. During power up, ensure that the following conditions are met to guaranty P.O.R. and LVCC operability.

1. "SDA='H'" and "SCL='L' or 'H'".
2. Follow the recommended conditions of  $t_R$ ,  $t_{OFF}$ ,  $V_{bot}$  so that P.O.R. will be activated during power up.

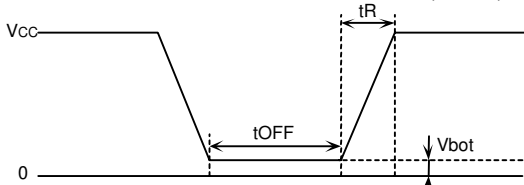

Figure 50. Rise waveform diagram

Recommended conditions of  $t_R$ ,  $t_{OFF}$ ,  $V_{bot}$

| $t_R$       | $t_{OFF}$  | $V_{bot}$  |
|-------------|------------|------------|
| Below 10ms  | Above 10ms | Below 0.3V |
| Below 100ms | Above 10ms | Below 0.2V |

3. Prevent SDA and SCL from being "Hi-Z".

In case that condition 1 and/or 2 cannot be met, take following actions.

- A) If unable to keep Condition 1 (SDA is "Low" during power up)
  - Make sure that SDA and SCL are "High" as in the figure below.

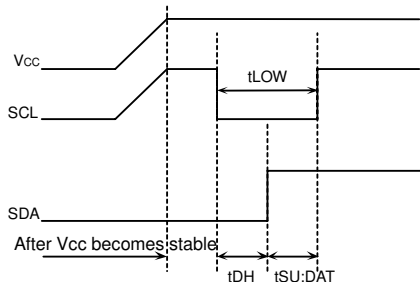

Figure 51. SCL='H' and SDA='L'

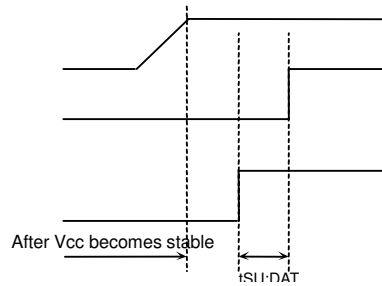

Figure 52. SCL='L' and SDA='L'

- B) If unable to keep Condition 2
  - After the power stabilizes, execute software reset. (See Figure 37)
- C) If unable to keep either Condition 1 or 2
  - Follow Instruction A first, then B

### ● LVCC Circuit

The LVCC circuit prevents Write operation at low voltage and prevents inadvertent writing. A voltage below the LVCC voltage (1.2V typ.) prohibits Write operation.

### ● Vcc Noise

#### ○ Bypass Capacitor

Noise and surges on the power line may cause abnormal function. It is recommended that bypass capacitors (0.1 $\mu$ F) be attached between Vcc and GND externally.

**●Notes for Use**

- 1) Described numeric values and data are design representative values, and the values are not guaranteed.
- 2) We believe that application circuit examples are recommendable, however, in actual use, confirm characteristics further sufficiently. In the case of use by changing the fixed number of external parts, make your decision with sufficient margin in consideration of static characteristics and transition characteristics and fluctuations of external parts and our LSI.
- 3) Absolute maximum ratings  
If the absolute maximum ratings such as impressed voltage and action temperature range and so forth are exceeded, LSI may be destructed. Do not impress voltage and temperature exceeding the absolute maximum ratings. In the case of fear exceeding the absolute maximum ratings, take physical safety countermeasures such as fuses, and see to it that conditions exceeding the absolute maximum ratings should not be impressed to LSI.
- 4) GND electric potential  
Set the voltage of GND terminal lowest at any action condition. Make sure that each terminal voltage is lower than that of GND terminal.
- 5) Heat design  
In consideration of permissible dissipation in actual use condition, carry out heat design with sufficient margin.
- 6) Terminal to terminal short circuit and wrong packaging  
When to package LSI on to a board, pay sufficient attention to LSI direction and displacement. Wrong packaging may destruct LSI. And in the case of short circuit between LSI terminals and terminals and power source, terminal and GND owing to foreign matter, LSI may be destructed.
- 7) Use in a strong electromagnetic field may cause malfunction, therefore, evaluate design sufficiently

**Status of this document**

The Japanese version of this document is formal specification. A customer may use this translation version only for a reference to help reading the formal version.

If there are any differences in translation version of this document formal version takes priority.

● **Ordering Information**

**Product Code Description**

|   |   |   |   |   |   |   |   |   |   |   |   |   |   |
|---|---|---|---|---|---|---|---|---|---|---|---|---|---|
| B | R | 3 | 4 | L | 0 | 2 | x | x | x | - | W | x | x |
|---|---|---|---|---|---|---|---|---|---|---|---|---|---|

**BUS type**

34 : I<sup>2</sup>C

**Operating temperature/  
Power source Voltage**

-40°C to +85°C/  
1.7V to 5.5V

**Capacity**

02=2K

**Package**

FV : SSOP-B8

FVT : TSSOP-B8

**Double Cell**

**Packaging and forming specification**

E2 : Embossed tape and reel (SSOP-B8 , TSSOP-B8)

●Physical Dimension Tape and Reel Information

SSOP-B8

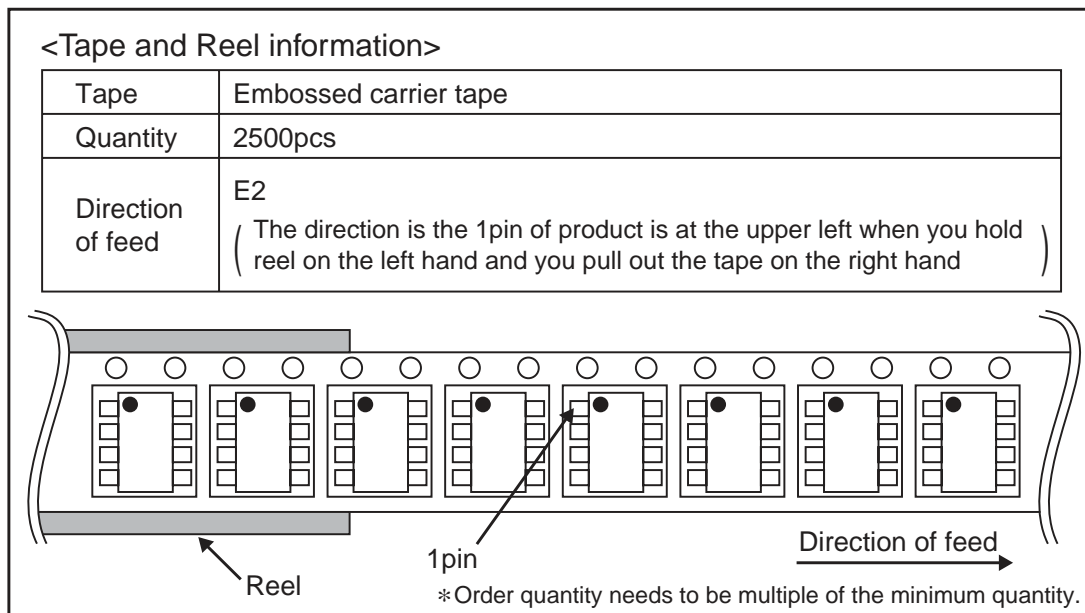
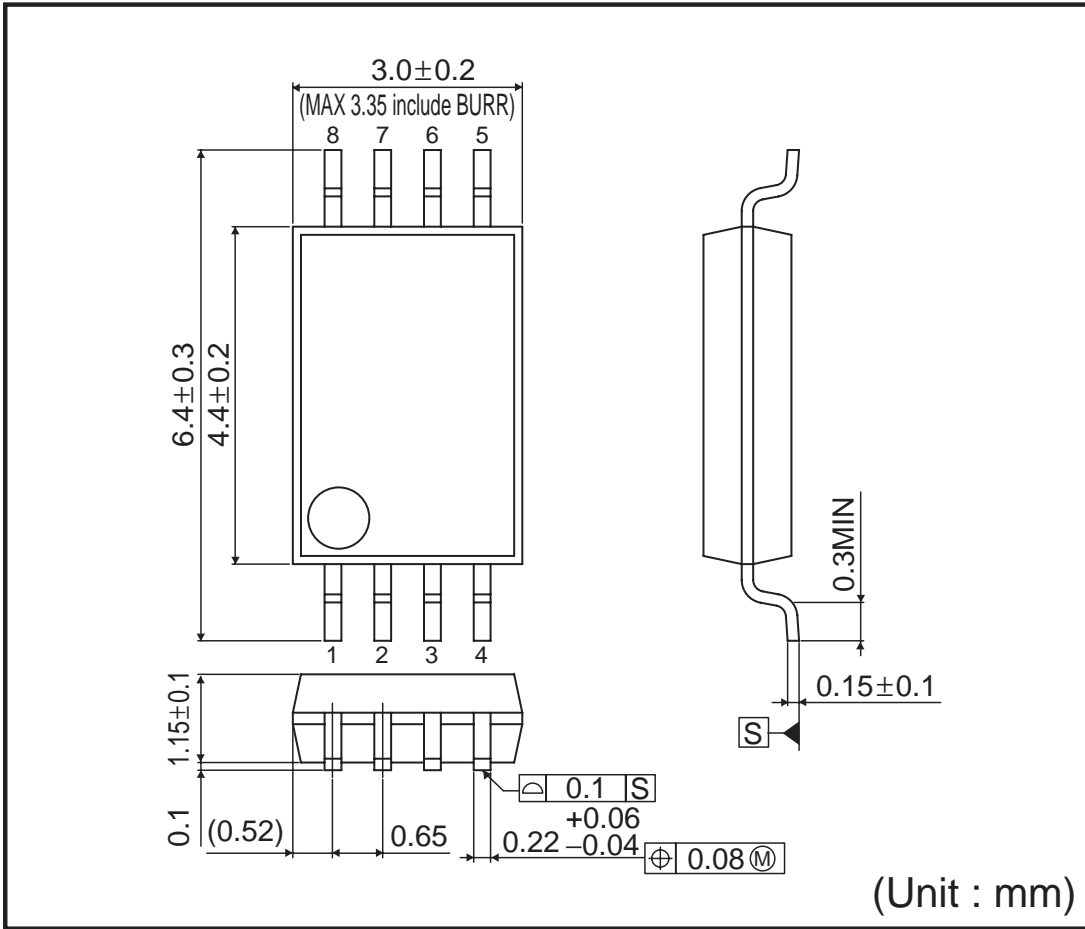



●Physical Dimension Tape and Reel Information - continued

TSSOP-B8



<Tape and Reel information>

|                   |   |
|-------------------|---|
| Tape              | Embossed carrier tape   |
| Quantity          | 3000pcs   |
| Direction of feed | E2<br>( The direction is the 1pin of product is at the upper left when you hold reel on the left hand and you pull out the tape on the right hand ) |

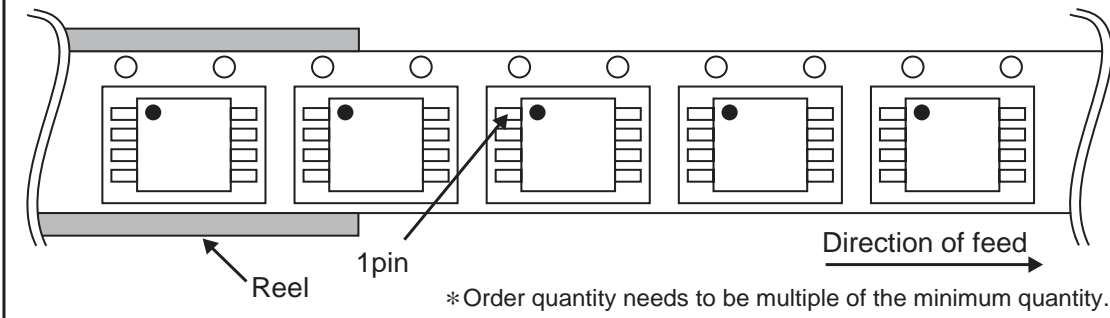

●Marking Diagrams

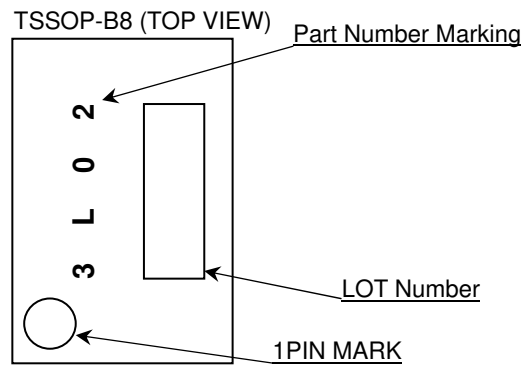
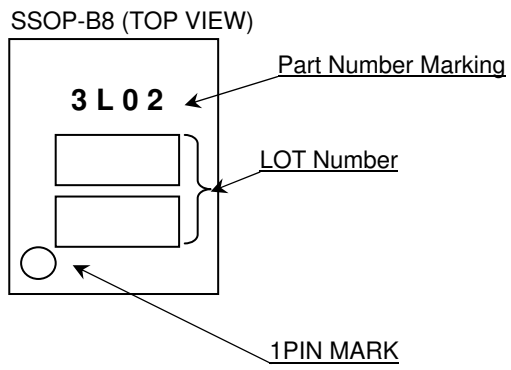

## ● Revision History

| Date        | Revision | Changes     |
|-------------|----------|-------------|
| 27.Aug.2012 | 001      | New Release |

# Notice

## Precaution on using ROHM Products

- Our Products are designed and manufactured for application in ordinary electronic equipments (such as AV equipment, OA equipment, telecommunication equipment, home electronic appliances, amusement equipment, etc.). If you intend to use our Products in devices requiring extremely high reliability (such as medical equipment <sup>(Note 1)</sup>, transport equipment, traffic equipment, aircraft/spacecraft, nuclear power controllers, fuel controllers, car equipment including car accessories, safety devices, etc.) and whose malfunction or failure may cause loss of human life, bodily injury or serious damage to property ("Specific Applications"), please consult with the ROHM sales representative in advance. Unless otherwise agreed in writing by ROHM in advance, ROHM shall not be in any way responsible or liable for any damages, expenses or losses incurred by you or third parties arising from the use of any ROHM's Products for Specific Applications.

(Note1) Medical Equipment Classification of the Specific Applications

| JAPAN     | USA       | EU         | CHINA     |
|-----------|-----------|------------|-----------|
| CLASS III | CLASS III | CLASS II b | CLASS III |
| CLASS IV  |           | CLASS III  |           |

- ROHM designs and manufactures its Products subject to strict quality control system. However, semiconductor products can fail or malfunction at a certain rate. Please be sure to implement, at your own responsibilities, adequate safety measures including but not limited to fail-safe design against the physical injury, damage to any property, which a failure or malfunction of our Products may cause. The following are examples of safety measures:
  - Installation of protection circuits or other protective devices to improve system safety
  - Installation of redundant circuits to reduce the impact of single or multiple circuit failure
- Our Products are designed and manufactured for use under standard conditions and not under any special or extraordinary environments or conditions, as exemplified below. Accordingly, ROHM shall not be in any way responsible or liable for any damages, expenses or losses arising from the use of any ROHM's Products under any special or extraordinary environments or conditions. If you intend to use our Products under any special or extraordinary environments or conditions (as exemplified below), your independent verification and confirmation of product performance, reliability, etc. prior to use, must be necessary:
  - Use of our Products in any types of liquid, including water, oils, chemicals, and organic solvents
  - Use of our Products outdoors or in places where the Products are exposed to direct sunlight or dust
  - Use of our Products in places where the Products are exposed to sea wind or corrosive gases, including Cl<sub>2</sub>, H<sub>2</sub>S, NH<sub>3</sub>, SO<sub>2</sub>, and NO<sub>2</sub>
  - Use of our Products in places where the Products are exposed to static electricity or electromagnetic waves
  - Use of our Products in proximity to heat-producing components, plastic cords, or other flammable items
  - Sealing or coating our Products with resin or other coating materials
  - Use of our Products without cleaning residue of flux (even if you use no-clean type fluxes, cleaning residue of flux is recommended); or Washing our Products by using water or water-soluble cleaning agents for cleaning residue after soldering
  - Use of the Products in places subject to dew condensation
- The Products are not subject to radiation-proof design.
- Please verify and confirm characteristics of the final or mounted products in using the Products.
- In particular, if a transient load (a large amount of load applied in a short period of time, such as pulse. is applied, confirmation of performance characteristics after on-board mounting is strongly recommended. Avoid applying power exceeding normal rated power; exceeding the power rating under steady-state loading condition may negatively affect product performance and reliability.
- De-rate Power Dissipation (Pd) depending on Ambient temperature (Ta). When used in sealed area, confirm the actual ambient temperature.
- Confirm that operation temperature is within the specified range described in the product specification.
- ROHM shall not be in any way responsible or liable for failure induced under deviant condition from what is defined in this document.

## Precaution for Mounting / Circuit board design

- When a highly active halogenous (chlorine, bromine, etc.) flux is used, the residue of flux may negatively affect product performance and reliability.
- In principle, the reflow soldering method must be used; if flow soldering method is preferred, please consult with the ROHM representative in advance.

For details, please refer to ROHM Mounting specification

**Precautions Regarding Application Examples and External Circuits**

1. If change is made to the constant of an external circuit, please allow a sufficient margin considering variations of the characteristics of the Products and external components, including transient characteristics, as well as static characteristics.
2. You agree that application notes, reference designs, and associated data and information contained in this document are presented only as guidance for Products use. Therefore, in case you use such information, you are solely responsible for it and you must exercise your own independent verification and judgment in the use of such information contained in this document. ROHM shall not be in any way responsible or liable for any damages, expenses or losses incurred by you or third parties arising from the use of such information.

**Precaution for Electrostatic**

This Product is electrostatic sensitive product, which may be damaged due to electrostatic discharge. Please take proper caution in your manufacturing process and storage so that voltage exceeding the Products maximum rating will not be applied to Products. Please take special care under dry condition (e.g. Grounding of human body / equipment / solder iron, isolation from charged objects, setting of Ionizer, friction prevention and temperature / humidity control).

**Precaution for Storage / Transportation**

1. Product performance and soldered connections may deteriorate if the Products are stored in the places where:
  - [a] the Products are exposed to sea winds or corrosive gases, including Cl<sub>2</sub>, H<sub>2</sub>S, NH<sub>3</sub>, SO<sub>2</sub>, and NO<sub>2</sub>
  - [b] the temperature or humidity exceeds those recommended by ROHM
  - [c] the Products are exposed to direct sunshine or condensation
  - [d] the Products are exposed to high Electrostatic
2. Even under ROHM recommended storage condition, solderability of products out of recommended storage time period may be degraded. It is strongly recommended to confirm solderability before using Products of which storage time is exceeding the recommended storage time period.
3. Store / transport cartons in the correct direction, which is indicated on a carton with a symbol. Otherwise bent leads may occur due to excessive stress applied when dropping of a carton.
4. Use Products within the specified time after opening a humidity barrier bag. Baking is required before using Products of which storage time is exceeding the recommended storage time period.

**Precaution for Product Label**

QR code printed on ROHM Products label is for ROHM's internal use only.

**Precaution for Disposition**

When disposing Products please dispose them properly using an authorized industry waste company.

**Precaution for Foreign Exchange and Foreign Trade act**

Since our Products might fall under controlled goods prescribed by the applicable foreign exchange and foreign trade act, please consult with ROHM representative in case of export.

**Precaution Regarding Intellectual Property Rights**

1. All information and data including but not limited to application example contained in this document is for reference only. ROHM does not warrant that foregoing information or data will not infringe any intellectual property rights or any other rights of any third party regarding such information or data. ROHM shall not be in any way responsible or liable for infringement of any intellectual property rights or other damages arising from use of such information or data.:
2. No license, expressly or implied, is granted hereby under any intellectual property rights or other rights of ROHM or any third parties with respect to the information contained in this document.

**Other Precaution**

1. This document may not be reprinted or reproduced, in whole or in part, without prior written consent of ROHM.
2. The Products may not be disassembled, converted, modified, reproduced or otherwise changed without prior written consent of ROHM.
3. In no event shall you use in any way whatsoever the Products and the related technical information contained in the Products or this document for any military purposes, including but not limited to, the development of mass-destruction weapons.
4. The proper names of companies or products described in this document are trademarks or registered trademarks of ROHM, its affiliated companies or third parties.

### General Precaution

1. Before you use our Products, you are requested to carefully read this document and fully understand its contents. ROHM shall not be in any way responsible or liable for failure, malfunction or accident arising from the use of any ROHM's Products against warning, caution or note contained in this document.
2. All information contained in this document is current as of the issuing date and subject to change without any prior notice. Before purchasing or using ROHM's Products, please confirm the latest information with a ROHM sales representative.
3. The information contained in this document is provided on an "as is" basis and ROHM does not warrant that all information contained in this document is accurate and/or error-free. ROHM shall not be in any way responsible or liable for any damages, expenses or losses incurred by you or third parties resulting from inaccuracy or errors of or concerning such information.