

600MHz Current Feedback Amplifiers with Enable

EL5164, EL5165, EL5364

The EL5164, EL5165, and EL5364 are current feedback amplifiers with a very high bandwidth of 600MHz. This makes these amplifiers ideal for today's high speed video and monitor applications.

With a supply current of just 3.5mA per amplifier and the ability to run from a single supply voltage from 5V to 12V, these amplifiers are also ideal for handheld, portable or battery-powered equipment.

The EL5164 and EL5364 also incorporate an enable and disable function to reduce the supply current to 14µA typical per amplifier. Allowing the \overline{CE} pin to float, or applying a low logic level, enables the amplifier.

The EL5165 is offered in the 5 Ld SOT-23 package, EL5164 is available in the 6 Ld SOT-23 and the industry-standard 8 Ld SOIC packages, and the EL5364 in a 16 Ld SOIC and 16 Ld QSOP packages. All operate over the industrial temperature range of -40°C to +85°C.

Features

- 600MHz -3dB bandwidth
- 4700V/µs slew rate
- 3.5mA supply current
- Single and dual supply operation, from 5V to 12V supply span
- Fast enable/disable (EL5164 and EL5364 only)
- Available in SOT-23 packages
- High speed, 1.4GHz product available (EL5166 and EL5167)
- 500MHz products available in Single (EL5162, EL5163), Dual (EL5262, EL5263) and Triple (EL5362)
- Pb-Free (RoHS compliant)

Applications

- Video amplifiers
- Cable drivers
- RGB amplifiers
- Test equipment
- Instrumentation
- Current to voltage converters

Pin Configurations

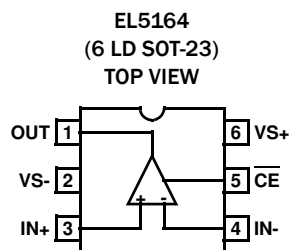
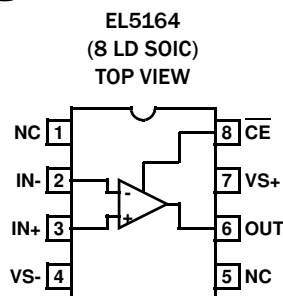

EL5164, EL5165, EL5364

Pin Configurations

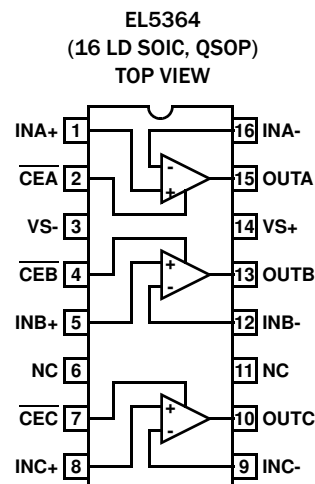
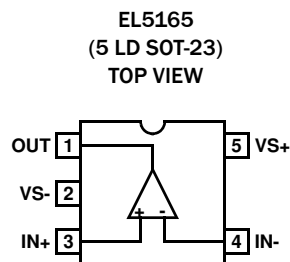

Ordering Information

PART NUMBER (Notes 2, 3)	PART MARKING	PACKAGE (Pb-free)	PKG. DWG. #
EL5164ISZ	5164ISZ	8 Ld SOIC (150 mil)	M8.15E
EL5164ISZ-T7 (Note 1)	5164ISZ	8 Ld SOIC (150 mil)	M8.15E
EL5164ISZ-T13 (Note 1)	5164ISZ	8 Ld SOIC (150 mil)	M8.15E
EL5164IWZ-T7 (Note 1)	BAMA (Note 4)	6 Ld SOT-23	P6.064A
EL5164IWZ-T7A (Note 1)	BAMA (Note 4)	6 Ld SOT-23	P6.064A
EL5165IWZ-T7 (Note 1)	BANA (Note 4)	5 Ld SOT-23	P5.064A
EL5165IWZ-T7A (Note 1)	BANA (Note 4)	5 Ld SOT-23	P5.064A
EL5364ISZ	EL5364ISZ	16 Ld SOIC (150 mil)	MDP0027
EL5364ISZ-T7 (Note 1)	EL5364ISZ	16 Ld SOIC (150 mil)	MDP0027
EL5364ISZ-T13 (Note 1)	EL5364ISZ	16 Ld SOIC (150 mil)	MDP0027
EL5364IUZ	5364IUZ	16 Ld QSOP (150 mil)	MDP0040
EL5364IUZ-T7 (Note 1)	5364IUZ	16 Ld QSOP (150 mil)	MDP0040
EL5364IUZ-T13 (Note 1)	5364IUZ	16 Ld QSOP (150 mil)	MDP0040
EL5364IUZA	5364IUZ	16 Ld QSOP (150 mil)	MDP0040
EL5364IUZA-T7 (Note 1)	5364IUZ	16 Ld QSOP (150 mil)	MDP0040
EL5364IUZA-T13 (Note 1)	5364IUZ	16 Ld QSOP (150 mil)	MDP0040

NOTES:

1. Please refer to [TB347](#) for details on reel specifications.
2. These Intersil Pb-free plastic packaged products employ special Pb-free material sets, molding compounds/die attach materials, and 100% matte tin plate plus anneal (e3 termination finish, which is RoHS compliant and compatible with both SnPb and Pb-free soldering operations). Intersil Pb-free products are MSL classified at Pb-free peak reflow temperatures that meet or exceed the Pb-free requirements of IPC/JEDEC J STD-020.
3. For Moisture Sensitivity Level (MSL), please see product information page for [EL5164](#), [EL5165](#), [EL5364](#). For more information on MSL, please see tech brief [TB363](#).
4. The part marking is located on the bottom of the part.

EL5164, EL5165, EL5364

Absolute Maximum Ratings (T_A = +25°C)

Supply Voltage between V _{S+} and V _{S-}	13.2V
Maximum Continuous Output Current	50mA
Pin Voltages	(V _{S-}) - 0.5V to (V _{S+}) + 0.5V
Supply Slewrate between V _{S+} and V _{S-}	1V/μs(Max)
V _{IN-DIFF} (V _{IN+} - V _{IN-}) (When Disabled)	±2V (Max)

Thermal Information

Maximum Power Dissipation	see curves on page 8
Maximum Storage Temperature Range	-65°C to +150°C
Ambient Operating Temperature Range	-40°C to +85°C
Maximum Operating Junction Temperature	+125°C
Pb-free reflow profile	see link below http://www.intersil.com/pbfree/Pb-FreeReflow.asp

CAUTION: Do not operate at or near the maximum ratings listed for extended periods of time. Exposure to such conditions may adversely impact product reliability and result in failures not covered by warranty

Electrical Specifications V_{S+} = +5V, V_{S-} = -5V, R_F = 750Ω for A_V = 1, R_F = 375Ω for A_V = 2, R_L = 150Ω, V_{CE} = 0V, T_A = +25°C unless otherwise specified. **Boldface limits apply across the operating temperature range, -40°C to +85°C.**

PARAMETER	DESCRIPTION	CONDITIONS	MIN (Note 6)	Typ	MAX (Note 6)	UNIT
AC PERFORMANCE						
BW	-3dB Bandwidth	A _V = +1, R _L = 500Ω, R _F = 510Ω		600		MHz
		A _V = +2, R _L = 150Ω, R _F = 412Ω		450		MHz
BW1	0.1dB Bandwidth	A _V = +2, R _L = 150Ω, R _F = 412Ω		50		MHz
SR	Slew Rate	V _{OUT} = -3V to +3V, A _V = +2, R _L = 100Ω (EL5164, EL5165)	3500	4700	7000	V/μs
		V _{OUT} = -3V to +3V, A _V = +2, R _L = 100Ω (EL5364)	3000	4200	6000	V/μs
t _S	0.1% Settling Time	V _{OUT} = -2.5V to +2.5V, A _V = +2, R _F = R _G = 1kΩ		15		ns
e _N	Input Voltage Noise	f = 1MHz		2.1		nV/√Hz
i _{N-}	IN- Input Current Noise	f = 1MHz		13		pA/√Hz
i _{N+}	IN+ Input Current Noise	f = 1MHz		13		pA/√Hz
HD2		5MHz, 2.5V _{p-p}		-81		dBc
HD3		5MHz, 2.5V _{p-p}		-74		dBc
dG	Differential Gain Error (Note 5)	A _V = +2		0.01		%
dP	Differential Phase Error (Note 5)	A _V = +2		0.01		°
DC PERFORMANCE						
V _{OS}	Offset Voltage		-5	1.5	+5	mV
T _C V _{OS}	Input Offset Voltage Temperature Coefficient	Measured from T _{MIN} to T _{MAX}		6		μV/°C
R _{OL}	Open Loop Transimpedance Gain		1.1	3		MΩ
INPUT CHARACTERISTICS						
CMIR	Common Mode Input Range	Guaranteed by CMRR test	±3	±3.3		V
CMRR	Common Mode Rejection Ratio	V _{IN} = ±3V	50	62	75	dB
-ICMR	- Input Current Common Mode Rejection		-1	0.1	+1	μA/V
+I _{IN}	+ Input Current		-10	2	+10	μA
-I _{IN}	- Input Current		-10	2	+10	μA
R _{IN}	Input Resistance	+ Input	300	650	1200	kΩ
C _{IN}	Input Capacitance			1		pF

EL5164, EL5165, EL5364

Electrical Specifications $V_{S+} = +5V$, $V_{S-} = -5V$, $R_F = 750\Omega$ for $A_V = 1$, $R_F = 375\Omega$ for $A_V = 2$, $R_L = 150\Omega$, $V_{\overline{CE}} = 0V$, $T_A = +25^\circ C$ unless otherwise specified. **Boldface limits apply across the operating temperature range, $-40^\circ C$ to $+85^\circ C$. (Continued)**

PARAMETER	DESCRIPTION	CONDITIONS	MIN (Note 6)	Typ	MAX (Note 6)	UNIT
OUTPUT CHARACTERISTICS						
V_O	Output Voltage Swing	$R_L = 150\Omega$ to GND	± 3.6	± 3.8	± 4.0	V
		$R_L = 1k\Omega$ to GND	± 3.9	± 4.1	± 4.2	V
I_{OUT}	Output Current	$R_L = 10\Omega$ to GND	100	140	190	mA
SUPPLY						
I_{SON}	Supply Current - Enabled, per Amplifier	No load, $V_{IN} = 0V$	3.2	3.5	4.2	mA
I_{SOFF+}	Supply Current - Disabled, per Amplifier	No load, $V_{IN} = 0V$, EL5164 and EL5364 Only	0		+25	μA
I_{SOFF-}	Supply Current - Disabled, per Amplifier		-25	-14	0	μA
PSRR	Power Supply Rejection Ratio	DC, $V_S = \pm 4.75V$ to $\pm 5.25V$	65	79		dB
-IPSR	- Input Current Power Supply Rejection	DC, $V_S = \pm 4.75V$ to $\pm 5.25V$	-1	0.1	+1	$\mu A/V$
ENABLE (EL5164, EL5364 ONLY)						
t_{EN}	Enable Time			200		ns
t_{DIS}	Disable Time			800		ns
I_{IHCE}	\overline{CE} Pin Input High Current	$\overline{CE} = V_{S+}$	1	10	+25	μA
I_{ILCE}	\overline{CE} Pin Input Low Current	$\overline{CE} = (V_{S+}) - 5V$	-1	0	+1	μA
V_{IHCE}	\overline{CE} Input High Voltage for Power-down		$(V_{S+}) - 1$			V
V_{ILCE}	\overline{CE} Input Low Voltage for Power-up				$(V_{S+}) - 3$	V

NOTES:

- Standard NTSC test, AC signal amplitude = $286mV_{p-p}$, $f = 3.58MHz$
- Parameters with MIN and/or MAX limits are 100% tested at $+25^\circ C$, unless otherwise specified. Temperature limits established by characterization and are not production tested.

Typical Performance Curves

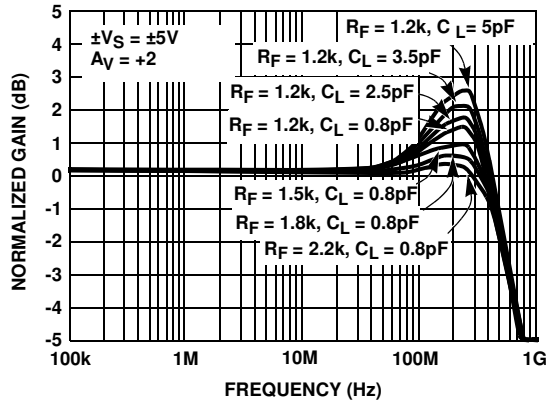

FIGURE 1. FREQUENCY RESPONSE FOR VARIOUS R_F AND C_L

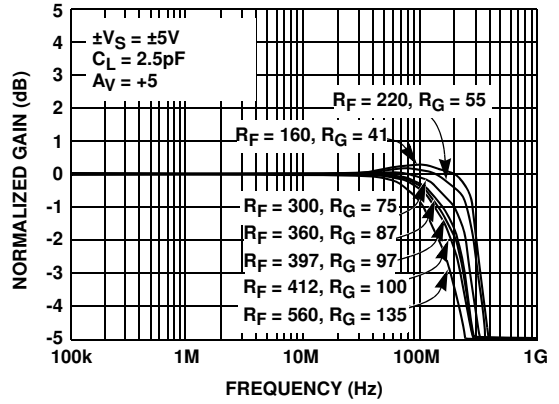

FIGURE 2. FREQUENCY RESPONSE FOR VARIOUS R_F

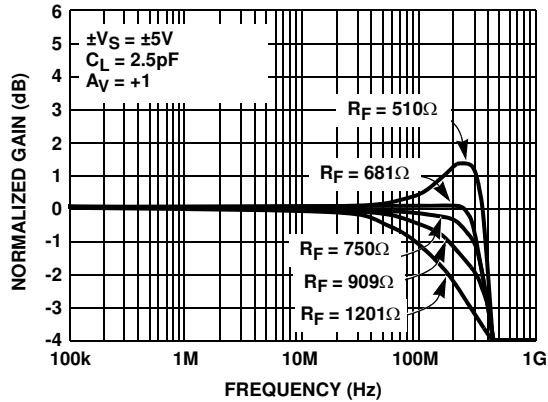

FIGURE 3. FREQUENCY RESPONSE FOR VARIOUS R_F

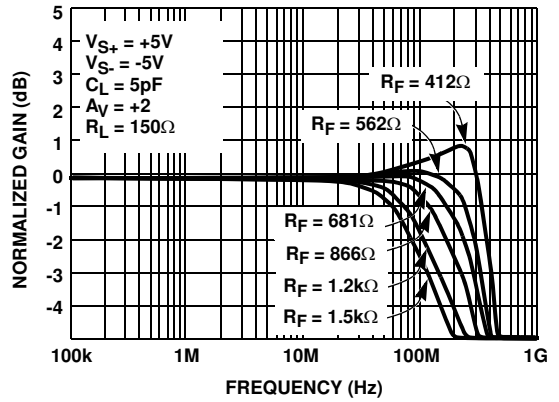

FIGURE 4. FREQUENCY RESPONSE FOR VARIOUS R_F

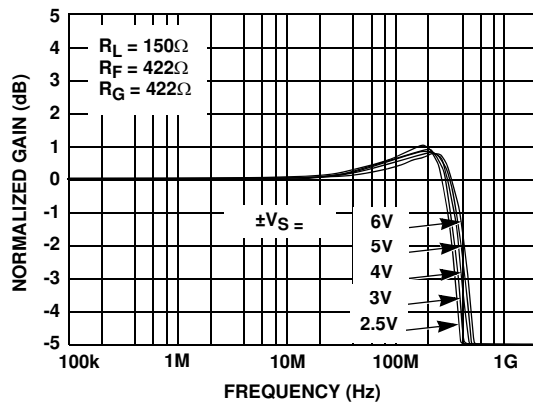

FIGURE 5. FREQUENCY RESPONSE FOR VARIOUS POWER SUPPLY VOLTAGES

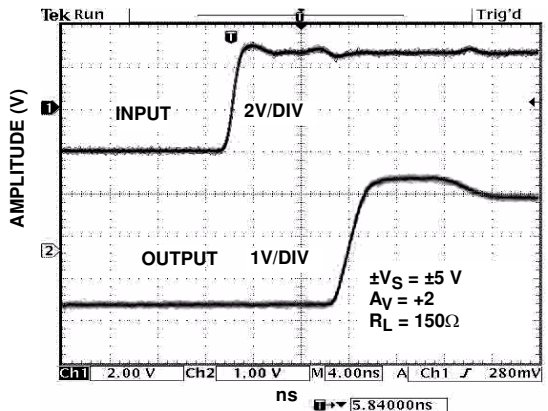

FIGURE 6. OUTPUT RISE TIME

Typical Performance Curves (Continued)

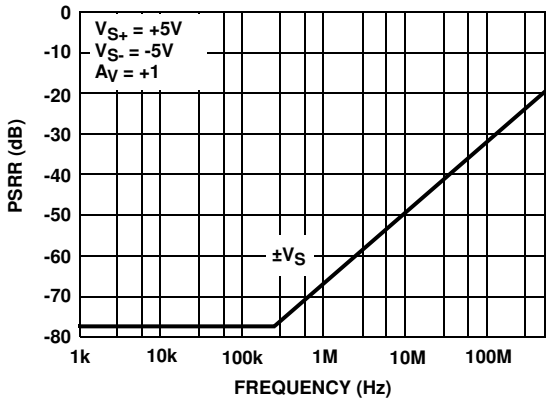

FIGURE 7. PSRR vs FREQUENCY

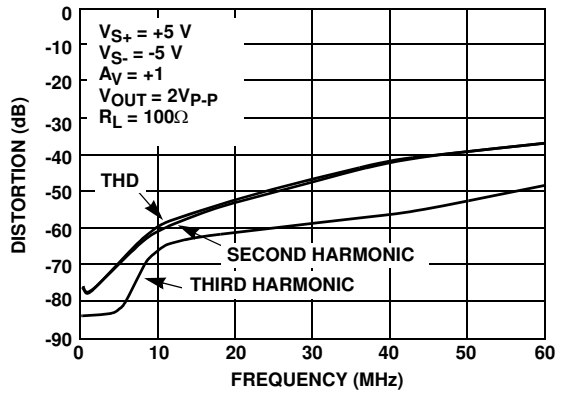

FIGURE 8. DISTORTION vs FREQUENCY ($A_V = +1$)

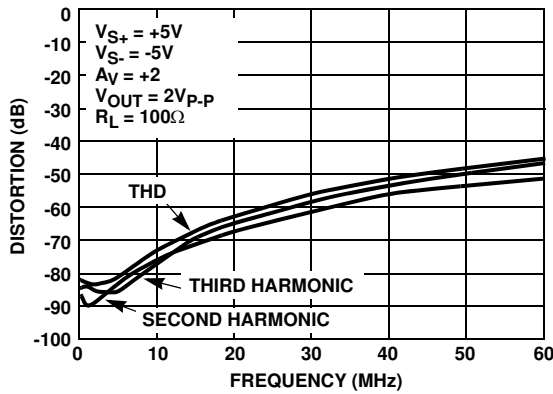

FIGURE 9. DISTORTION vs FREQUENCY ($A_V = +2$)

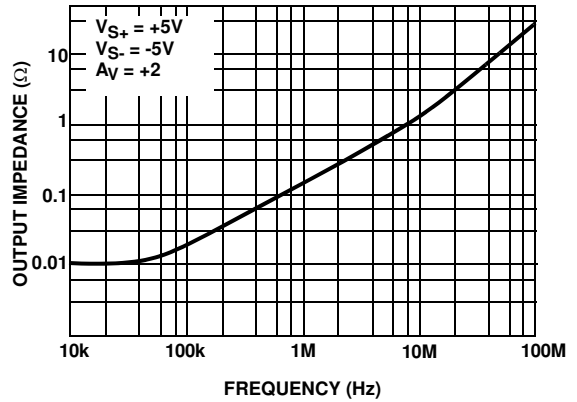

FIGURE 10. OUTPUT IMPEDANCE vs FREQUENCY

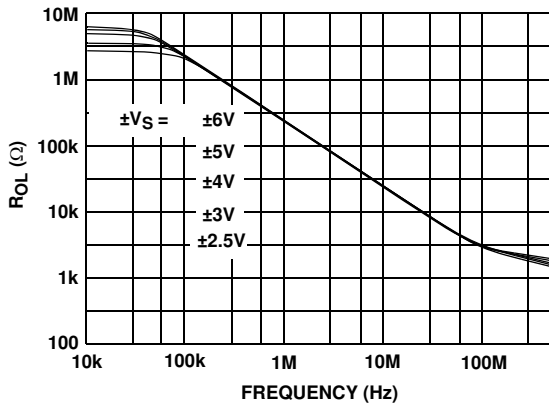

FIGURE 11. OPEN LOOP TRANSIMPEDANCE GAIN (R_{OL}) vs FREQUENCY FOR VARIOUS SUPPLY VOLTAGES

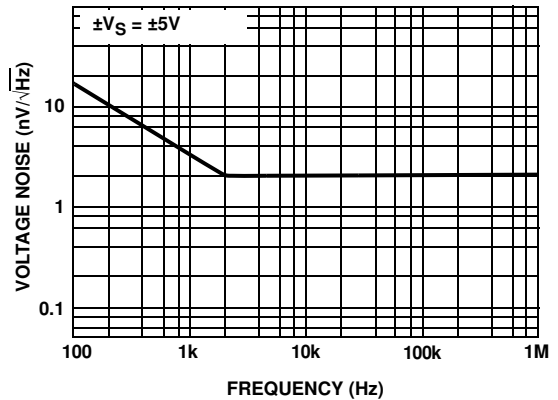

FIGURE 12. VOLTAGE NOISE vs FREQUENCY

Typical Performance Curves (Continued)

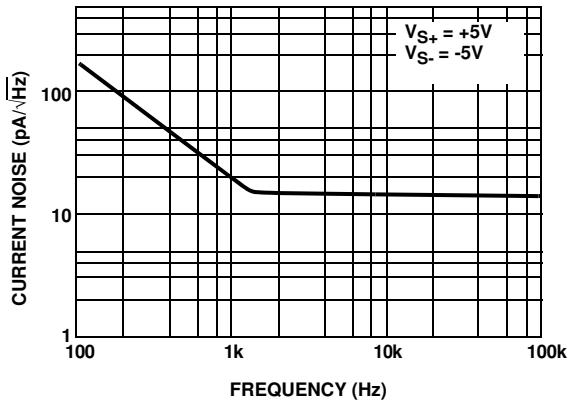

FIGURE 13. CURRENT NOISE vs FREQUENCY

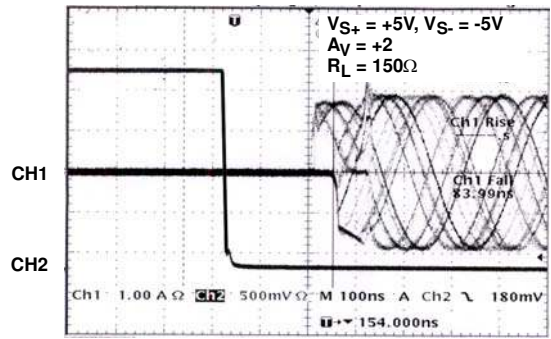

FIGURE 14. TURN-ON DELAY, $V_{IN} = 100mV_{p-p}$

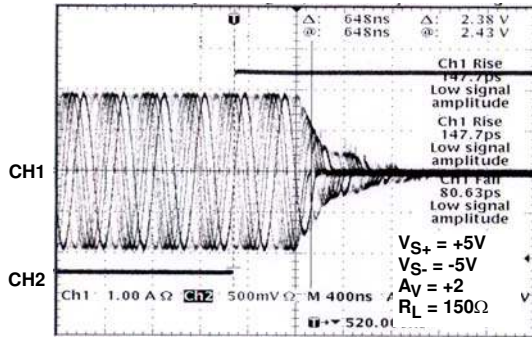

FIGURE 15. TURN-OFF DELAY, $V_{IN} = 100mV_{p-p}$

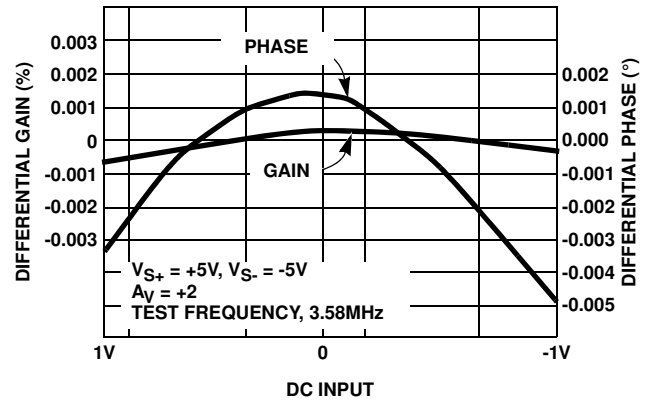

FIGURE 16. DIFFERENTIAL GAIN/PHASE vs DC INPUT VOLTAGE AT 3.58MHz

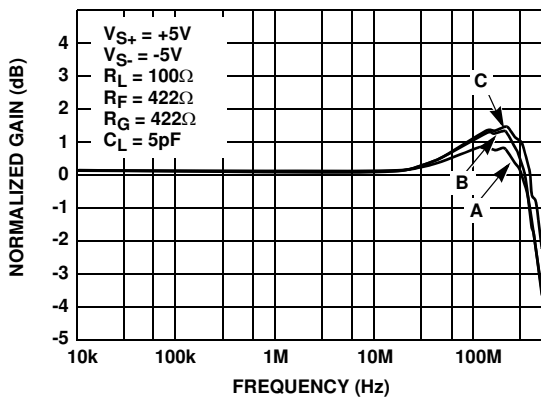

FIGURE 17. FREQUENCY RESPONSE FOR VARIOUS CHANNELS (EL5364)

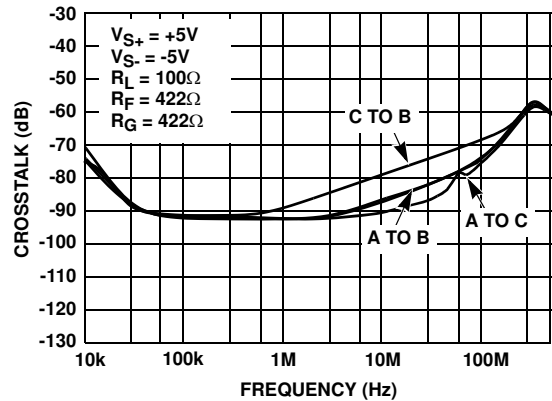

FIGURE 18. CROSSTALK BETWEEN CHANNELS (EL5364)

Typical Performance Curves (Continued)

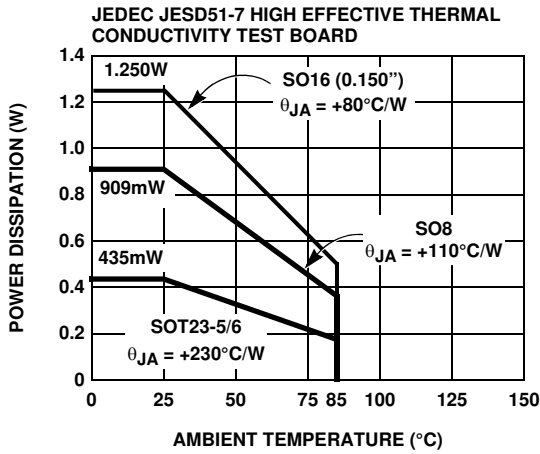

FIGURE 19. PACKAGE POWER DISSIPATION vs AMBIENT TEMPERATURE

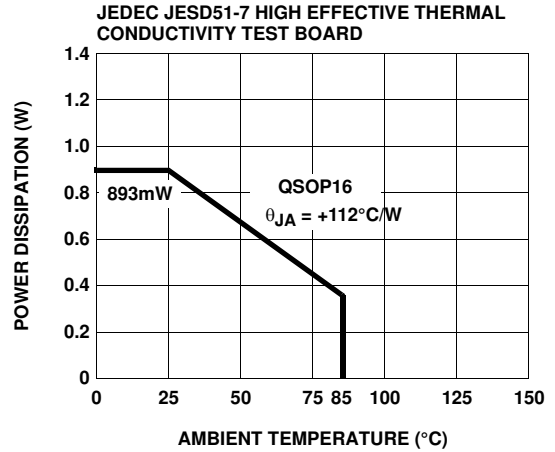

FIGURE 20. PACKAGE POWER DISSIPATION vs AMBIENT TEMPERATURE

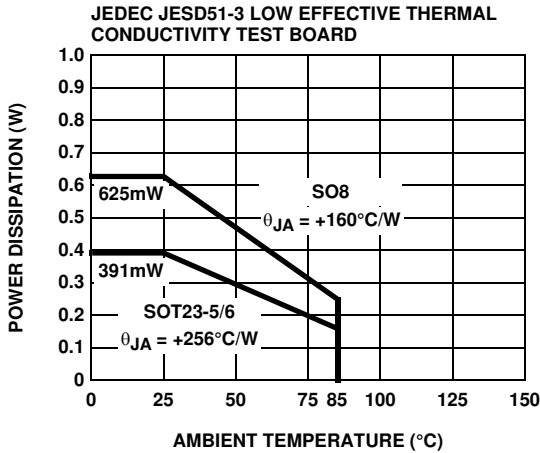

FIGURE 21. PACKAGE POWER DISSIPATION vs AMBIENT TEMPERATURE

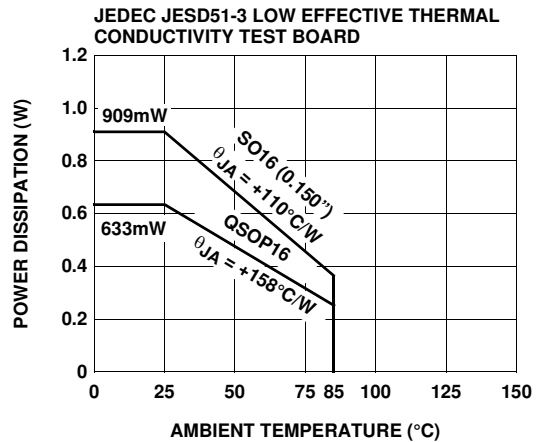

FIGURE 22. PACKAGE POWER DISSIPATION vs AMBIENT TEMPERATURE

Pin Descriptions

EL5164 (8 Ld SOIC)	EL5164 (6 Ld SOT-23)	EL5165	EL5364	Pin Name	Function	Equivalent Circuit
1, 5			6, 11	NC	Not connected	
2	4	4	9, 12, 16	IN-	Inverting input	<p style="text-align: center;">CIRCUIT 1</p>
3	3	3	1, 5, 8	IN+	Non-inverting input	(See circuit 1)
4	2	2	3	VS-	Negative supply	
6	1	1	10, 13, 15	OUT	Output	<p style="text-align: center;">CIRCUIT 2</p>
7	6	5	14	VS+	Positive supply	
8	5		2, 4, 7	$\overline{\text{CE}}$	Chip enable, allowing the pin to float or applying a low logic level enables the corresponding amplifier.	<p style="text-align: center;">CIRCUIT 3</p>

Applications Information

Product Description

The EL5164, EL5165, and EL5364 are current-feedback operational amplifiers that offer a wide -3dB bandwidth of 600MHz and a low supply current of 3.5mA per amplifier. The EL5164, EL5165, and EL5364 work with supply voltages ranging from a single 5V to 10V and they are also capable of swinging to within 1V of either supply on the output. Because of their current-feedback topology, the EL5164, EL5165, and EL5364 do not have the normal gain-bandwidth product associated with voltage-feedback operational amplifiers. Instead, their -3dB bandwidth remains relatively constant as closed-loop gain increases. This combination of high bandwidth and low power, together with aggressive pricing makes the EL5164, EL5165, and EL5364 ideal choices for many low-power/high-bandwidth applications such as portable, handheld, or battery-powered equipment. For varying bandwidth needs, consider the EL5166 and EL5167 with 1.4GHz bandwidth and an 8.5mA supply current, or the EL5162 and EL5163 with 500MHz bandwidth and a 1.5mA supply current. Versions include single, dual, and triple amp configurations with 5 Ld SOT-23, 16 Ld QSOP, and 8 Ld SOIC or 16 Ld SOIC outlines.

Power Supply Bypassing and Printed Circuit Board Layout

As with any high frequency device, good printed circuit board layout is necessary for optimum performance. Low impedance ground plane construction is essential. Surface mount components are recommended, but if leaded components are used, lead lengths should be as short as possible. The power supply pins must be well bypassed to reduce the risk of oscillation. The combination of a 4.7μF tantalum capacitor in parallel with a 0.01μF capacitor has been shown to work well when placed at each supply pin.

For good AC performance, parasitic capacitance should be kept to a minimum, especially at the inverting input. (See the "Capacitance at the Inverting Input" on page 10). Even when ground plane construction is used, it should be removed from the area near the inverting input to minimize any stray capacitance at that node. Carbon or Metal-Film resistors are acceptable with the Metal-Film resistors giving slightly less peaking and bandwidth because of additional series inductance. Use of sockets, particularly for the SO package, should be avoided if possible. Sockets add parasitic inductance and capacitance which results in additional peaking and overshoot.

Disable/Power-Down

The EL5164 and EL5364 amplifiers can be disabled, placing their outputs in a high impedance state. When disabled, the amplifiers supply current reduces to $<25\mu\text{A}$ per amplifier. An amplifier disables when its $\overline{\text{CE}}$ pin is pulled up to within 1V of the positive supply. Similarly, the amplifier is enabled by floating or pulling its $\overline{\text{CE}}$ pin to at least 3V below the positive supply. For a $\pm 5\text{V}$ supply, this means that an amplifier enables when its $\overline{\text{CE}}$ is 2V or less, and disables when $\overline{\text{CE}}$ is above 4V. Although the logic levels are not standard TTL, this choice of logic voltages allows the amplifiers to be enabled by tying $\overline{\text{CE}}$ to ground, even in 5V single supply applications. The $\overline{\text{CE}}$ pin can be driven from CMOS outputs.

When the amplifier is disabled, if the positive input is driven beyond $\pm 2\text{V}$ with respect to the negative input, the device can become active and output the signal. An input diode clamp network D_1 and D_2 , as shown in Figure 23, can be used to keep the device disabled while a large input signal is present.

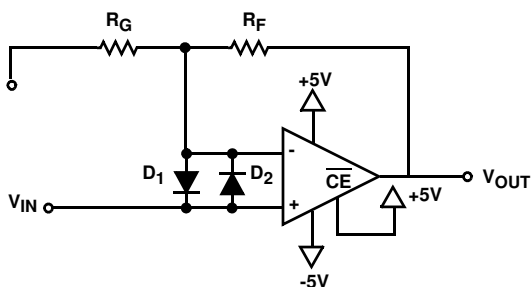

FIGURE 23. DISABLED AMPLIFIER

Capacitance at the Inverting Input

Any manufacturer's high-speed voltage- or current-feedback amplifier can be affected by stray capacitance at the inverting input. For inverting gains, this parasitic capacitance has little effect because the inverting input is a virtual ground, but for non-inverting gains, this capacitance (in conjunction with the feedback and gain resistors) creates a pole in the feedback path of the amplifier. This pole, if low enough in frequency, has the same destabilizing effect as a zero in the forward open-loop response. The use of large-value feedback and gain resistors exacerbates the problem by further lowering the pole frequency (increasing the possibility of oscillation.)

The EL5164, EL5165, and EL5364 are optimized for a 510Ω feedback resistor at $A_V = +1$. With the high bandwidth of these amplifiers, these resistor values might cause stability problems when combined with parasitic capacitance, thus ground plane is not recommended around the inverting input pin of the amplifier.

Feedback Resistor Values

The EL5164, EL5165, and EL5364 have been designed and specified for a gain of +2 with R_F approximately 412Ω . This value of feedback resistor gives 450MHz of -3dB bandwidth at $A_V = 2$ with 1dB of peaking. With $A_V = -2$, an R_F of 300Ω gives 275MHz of bandwidth with 1dB of peaking. Since the EL5164, EL5165, and EL5364 are current-feedback amplifiers, it is also possible to change the value of R_F to get more bandwidth. As seen in the curves of "Frequency Response for Various R_F ", bandwidth and

peaking can be easily modified by varying the value of the feedback resistor.

Because the EL5164, EL5165, and EL5364 are current-feedback amplifiers, their gain-bandwidth product is not a constant for different closed-loop gains. This feature actually allows the EL5164, EL5165, and EL5364 to maintain about the same -3dB bandwidth. As gain is increased, bandwidth decreases slightly while stability increases. Since the loop stability is improving with higher closed-loop gains, it becomes possible to reduce the value of R_F below the specified 412Ω and still retain stability, resulting in only a slight loss of bandwidth with increased closed-loop gain.

Supply Voltage Range and Single-Supply Operation

The EL5164, EL5165, and EL5364 are designed to operate with supply voltages having a span of 5V to 10V. In practical terms, this means that they will operate on dual supplies ranging from $\pm 2.5\text{V}$ to $\pm 5\text{V}$. With a single-supply, the EL5164, EL5165, and EL5364 will operate from 5V to 10V.

As supply voltages continue to decrease, it becomes necessary to provide input and output voltage ranges that can get as close as possible to the supply voltages. The EL5164, EL5165, and EL5364 have an input range which extends to within 2V of either supply. For example, on $\pm 5\text{V}$ supplies, the EL5164, EL5165, and EL5364 have an input range which spans $\pm 3\text{V}$. The output range of the EL5164, EL5165, and EL5364 is also quite large, extending to within 1V of the supply rail. On a $\pm 5\text{V}$ supply, the output is therefore capable of swinging from -4V to +4V. Single-supply output range is larger because of the increased negative swing due to the external pull-down resistor to ground.

Video Performance

For good video performance, an amplifier must maintain the same output impedance and the same frequency response as DC levels are changed at the output. This is especially difficult when driving a standard video load of 150Ω , because of the change in output current with DC level. Previously, good differential gain could only be achieved by running high idle currents through the output transistors (to reduce variations in output impedance.) These currents were typically comparable to the entire 3.5mA supply current of each EL5164, EL5165, and EL5364 amplifier. Special circuitry has been incorporated in the EL5164, EL5165, and EL5364 to reduce the variation of output impedance with current output. This results in dG and dP specifications of 0.01% and 0.01° , while driving 150Ω at a gain of 2.

Video performance has also been measured with a 500Ω load at a gain of +1. Under these conditions, the EL5164, EL5165, and EL5364 have dG and dP specifications of 0.01% and 0.01° , respectively.

EL5164, EL5165, EL5364

Output Drive Capability

In spite of their low 3.5mA of supply current, the EL5164, EL5165, and EL5364 are capable of providing a minimum of $\pm 100\text{mA}$ of output current. With a minimum of $\pm 100\text{mA}$ of output drive, the EL5164, EL5165, and EL5364 are capable of driving 50Ω loads to both rails, making it an excellent choice for driving isolation transformers in telecommunications applications.

Driving Cables and Capacitive Loads

When used as a cable driver, double termination is always recommended for reflection-free performance. For those applications, the back-termination series resistor will decouple the EL5164, EL5165, and EL5364 from the cable and allow extensive capacitive drive. However, other applications may have high capacitive loads without a back-termination resistor. In these applications, a small resistor (usually between 5Ω and 50Ω) can be placed in series with the output to eliminate most peaking. The gain resistor (R_G) can then be chosen to make up for any gain loss which may be created by this additional resistor at the output. In many cases it is also possible to simply increase the value of the feedback resistor (R_F) to reduce the peaking.

Current Limiting

The EL5164, EL5165, and EL5364 have no internal output current-limiting circuitry. If the output is shorted, it is possible to exceed the Absolute Maximum Rating for output current or power dissipation, potentially resulting in the destruction of the device.

Power Dissipation

With the high output drive capability of the EL5164, EL5165, and EL5364, it is possible to exceed the $+125^\circ\text{C}$ Absolute Maximum junction temperature under certain very high load current conditions. Generally speaking when R_L falls below about 25Ω , it is important to calculate the maximum junction temperature (T_{JMAX}) for the application, to determine if power supply voltages, load conditions, or package type need to be modified to remain in the safe operating area. These parameters are calculated in Equation 1:

$$T_{JMAX} = T_{MAX} + (\theta_{JA} \times n \times PD_{MAX}) \quad (\text{EQ. 1})$$

where:

- T_{MAX} = Maximum ambient temperature
- θ_{JA} = Thermal resistance of the package
- n = Number of amplifiers in the package
- PD_{MAX} = Maximum power dissipation of each amplifier in the package

PD_{MAX} for each amplifier can be calculated in Equation 2:

$$PD_{MAX} = (2 \times V_S \times I_{SMAX}) + \left[(V_S - V_{OUTMAX}) \times \frac{V_{OUTMAX}}{R_L} \right] \quad (\text{EQ. 2})$$

where:

- V_S = Supply voltage
- I_{SMAX} = Maximum supply current of 4.2mA
- V_{OUTMAX} = Maximum output voltage (required)
- R_L = Load resistance

Typical Application Circuits

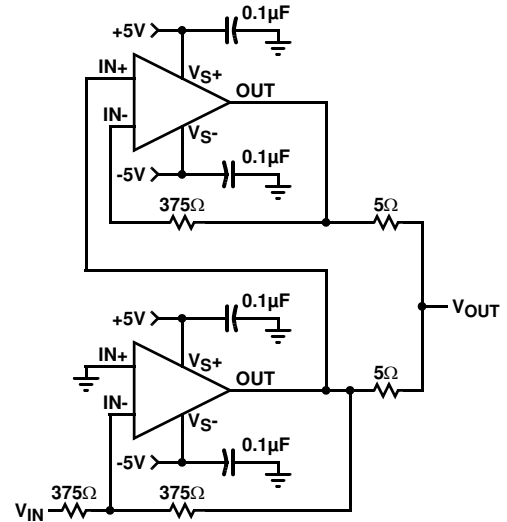

FIGURE 24. INVERTING 200mA OUTPUT CURRENT DISTRIBUTION AMPLIFIER

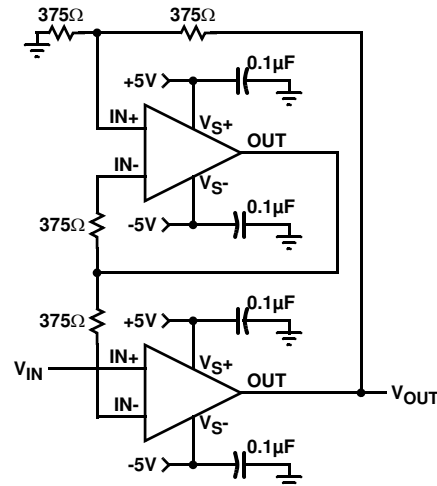

FIGURE 25. FAST-SETTLING PRECISION AMPLIFIER

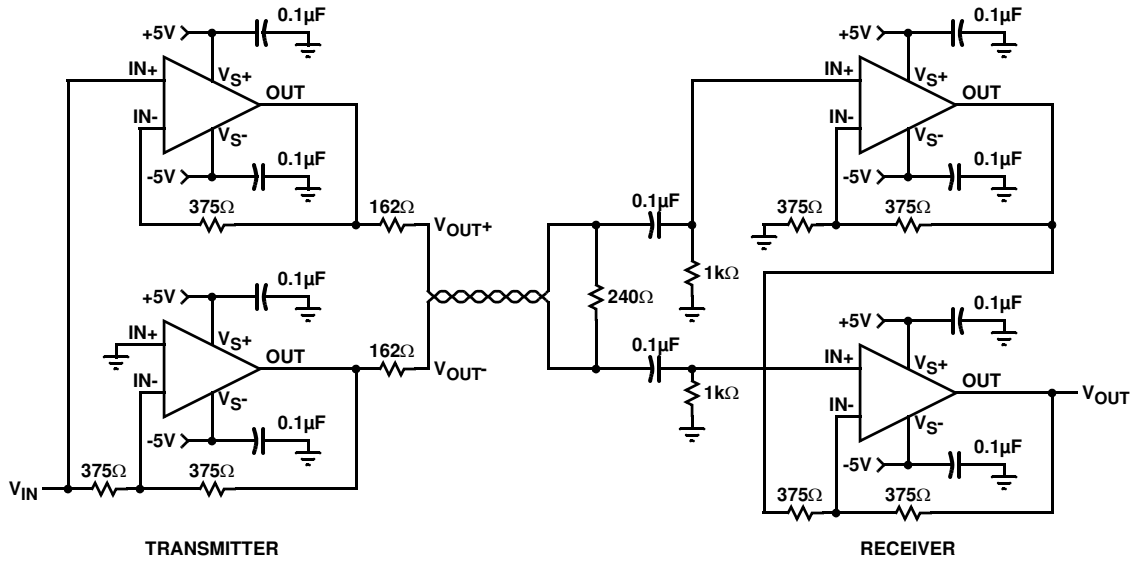

FIGURE 26. DIFFERENTIAL LINE DRIVER/RECEIVER

For additional products, see www.intersil.com/en/products.html

Intersil products are manufactured, assembled and tested utilizing ISO9001 quality systems as noted in the quality certifications found at www.intersil.com/en/support/qualandreliability.html

Intersil products are sold by description only. Intersil Corporation reserves the right to make changes in circuit design, software and/or specifications at any time without notice. Accordingly, the reader is cautioned to verify that data sheets are current before placing orders. Information furnished by Intersil is believed to be accurate and reliable. However, no responsibility is assumed by Intersil or its subsidiaries for its use; nor for any infringements of patents or other rights of third parties which may result from its use. No license is granted by implication or otherwise under any patent or patent rights of Intersil or its subsidiaries.

For information regarding Intersil Corporation and its products, see www.intersil.com

Package Outline Drawing

M8.15E

8 LEAD NARROW BODY SMALL OUTLINE PLASTIC PACKAGE

Rev 0, 08/09

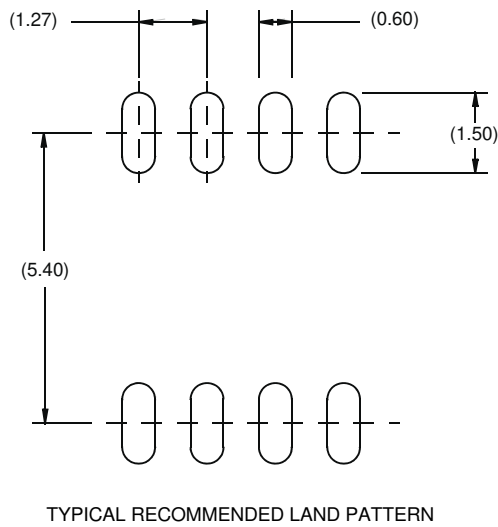
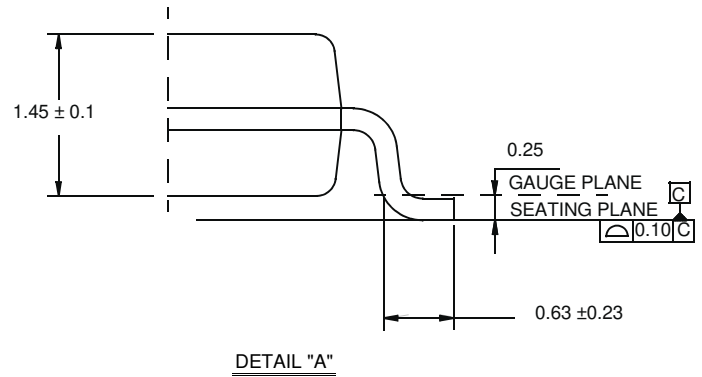
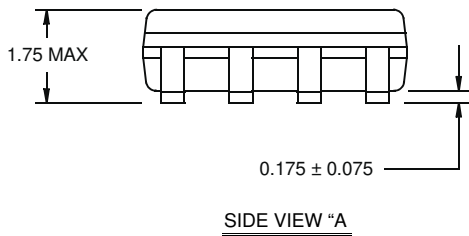
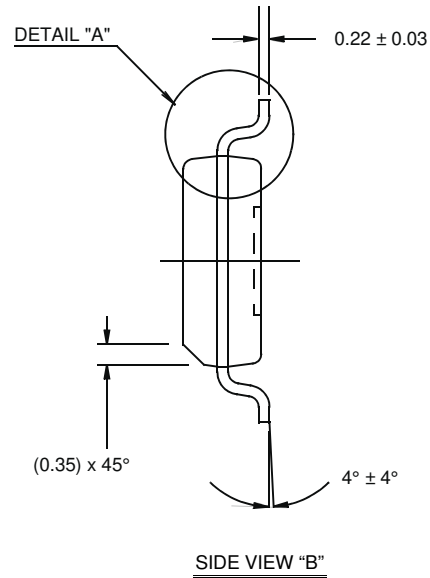
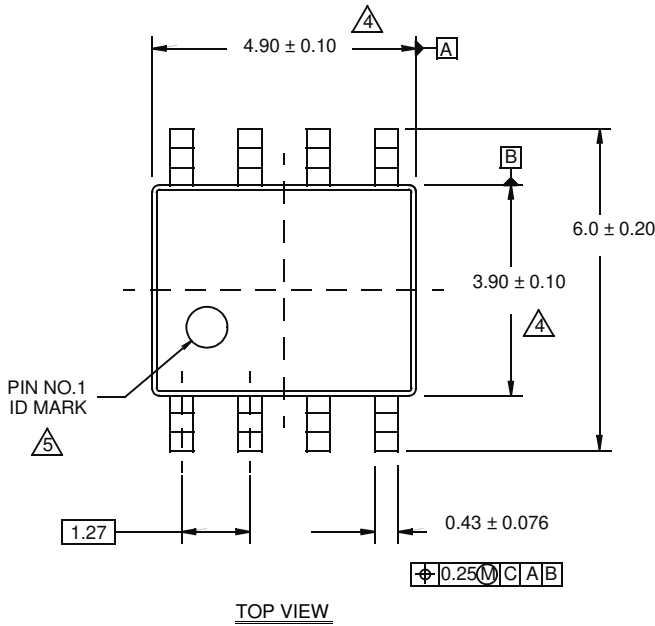

NOTES:

1. Dimensions are in millimeters.
Dimensions in () for Reference Only.
2. Dimensioning and tolerancing conform to AMSE Y14.5m-1994.
3. Unless otherwise specified, tolerance : Decimal ± 0.05
4. Dimension does not include interlead flash or protrusions.
Interlead flash or protrusions shall not exceed 0.25mm per side.
5. The pin #1 identifier may be either a mold or mark feature.
6. Reference to JEDEC MS-012.

Package Outline Drawing

P6.064A

6 LEAD SMALL OUTLINE TRANSISTOR PLASTIC PACKAGE

Rev 0, 2/10

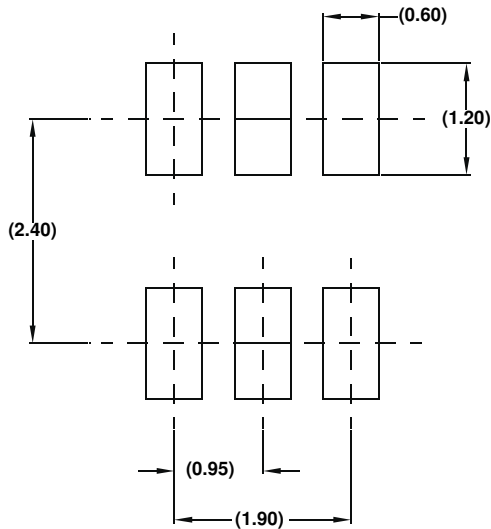
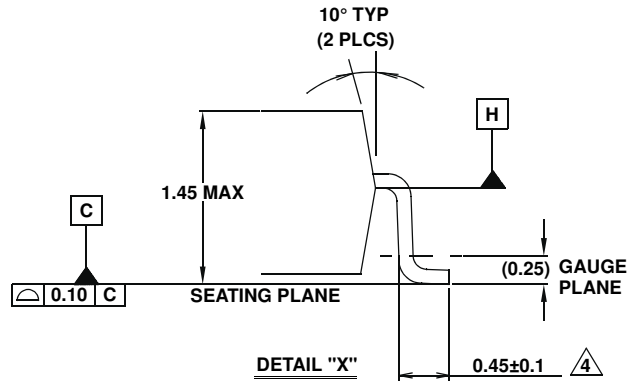
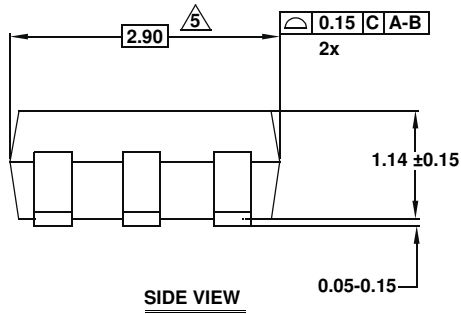
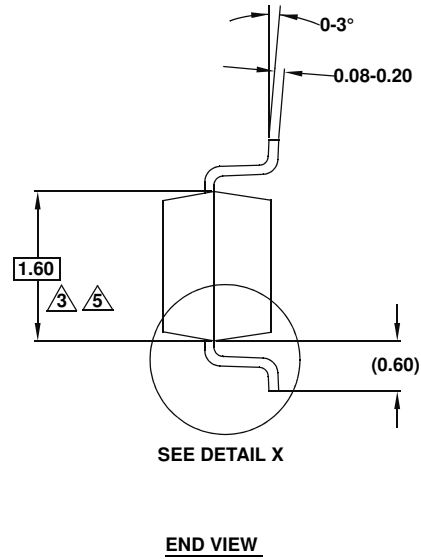
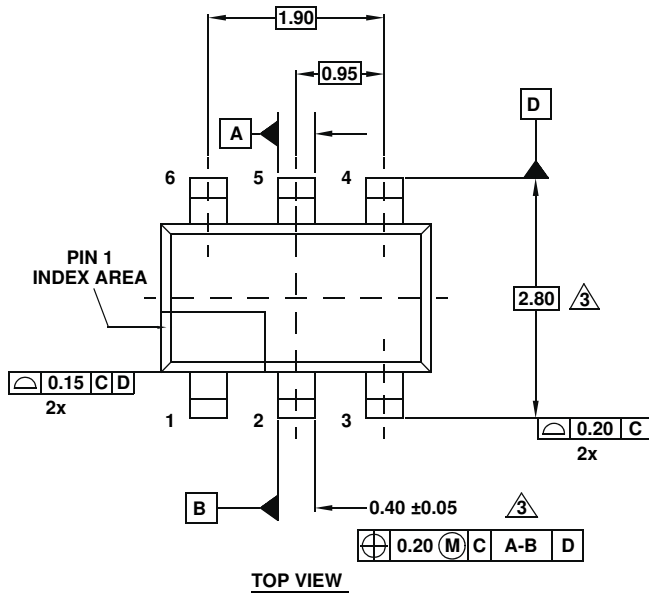

NOTES:

1. Dimensions are in millimeters.
Dimensions in () for Reference Only.
2. Dimensioning and tolerancing conform to ASME Y14.5M-1994.
3. Dimension is exclusive of mold flash, protrusions or gate burrs.
4. Foot length is measured at reference to gauge plane.
5. This dimension is measured at Datum "H".
6. Package conforms to JEDEC MO-178AA.

Package Outline Drawing

P5.064A

5 LEAD SMALL OUTLINE TRANSISTOR PLASTIC PACKAGE

Rev 0, 2/10

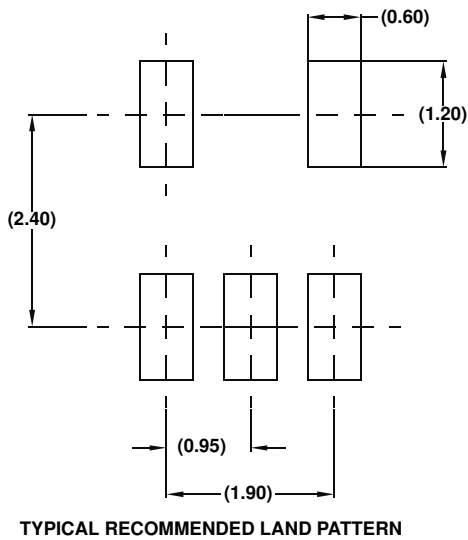
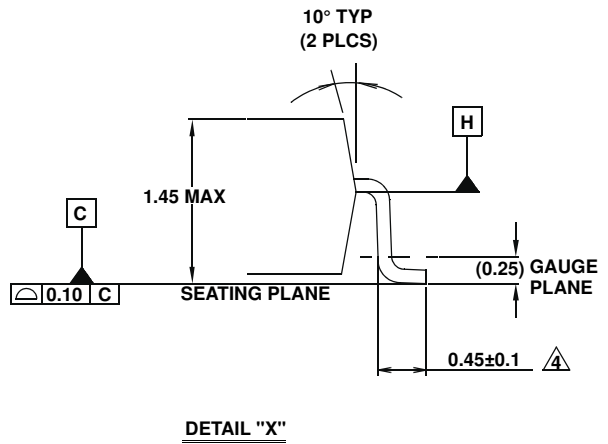
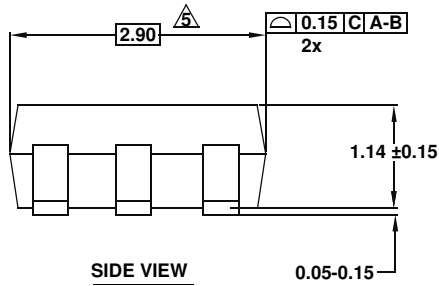
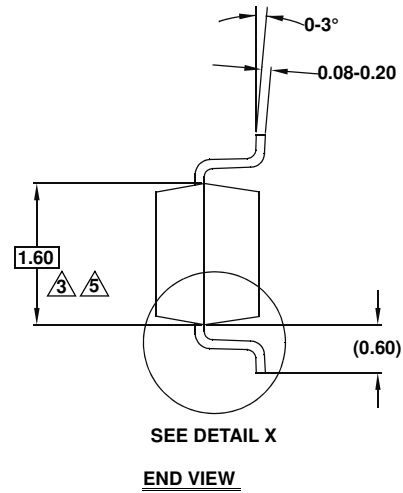
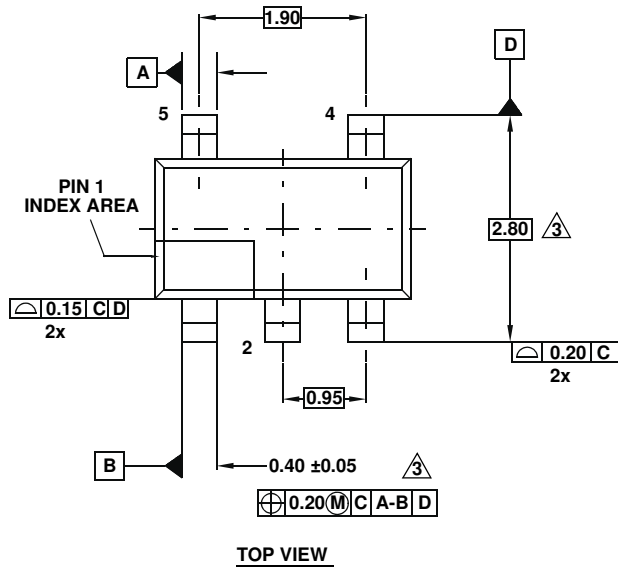

NOTES:

1. Dimensions are in millimeters.
Dimensions in () for Reference Only.
2. Dimensioning and tolerancing conform to ASME Y14.5M-1994.
3. Dimension is exclusive of mold flash, protrusions or gate burrs.
4. Foot length is measured at reference to gauge plane.
5. This dimension is measured at Datum "H".
6. Package conforms to JEDEC MO-178AA.

EL5164, EL5165, EL5364

Small Outline Package Family (SO)

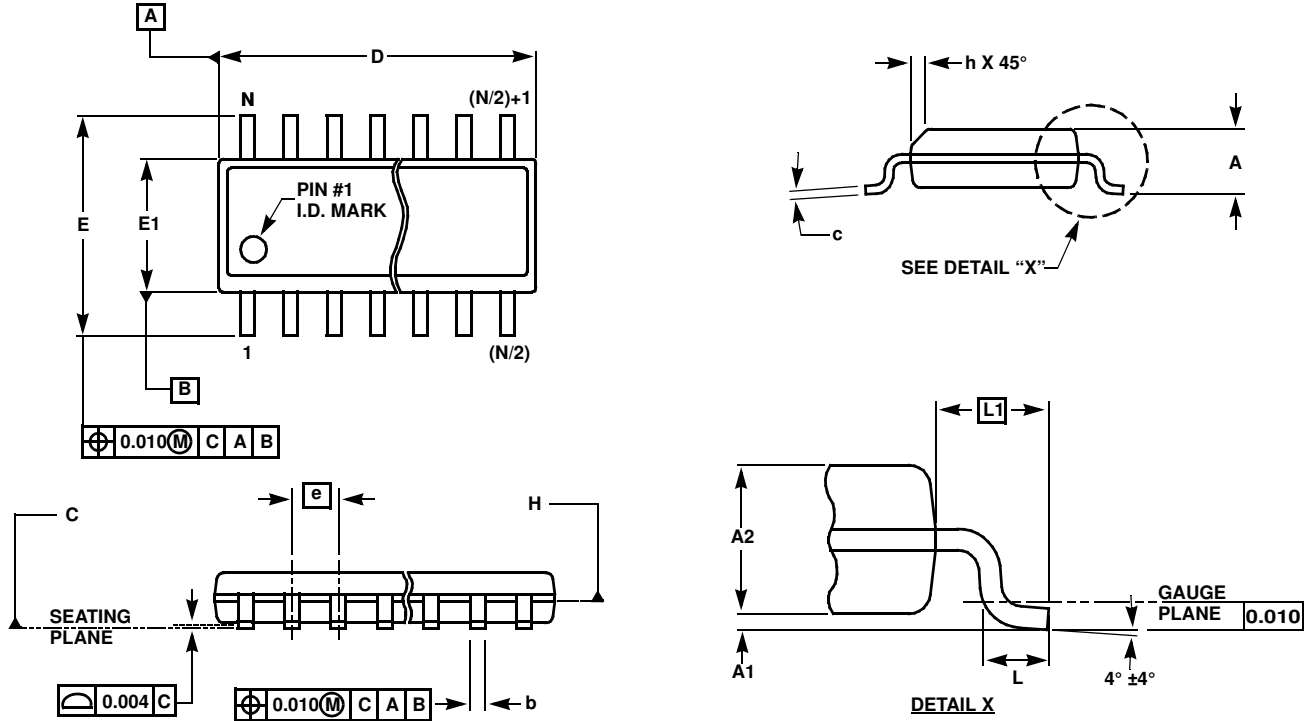

MDP0027

SMALL OUTLINE PACKAGE FAMILY (SO)

SYMBOL	INCHES							TOLERANCE	NOTES
	SO-8	SO-14	SO16 (0.150")	SO16 (0.300") (SOL-16)	SO20 (SOL-20)	SO24 (SOL-24)	SO28 (SOL-28)		
A	0.068	0.068	0.068	0.104	0.104	0.104	0.104	MAX	-
A1	0.006	0.006	0.006	0.007	0.007	0.007	0.007	±0.003	-
A2	0.057	0.057	0.057	0.092	0.092	0.092	0.092	±0.002	-
b	0.017	0.017	0.017	0.017	0.017	0.017	0.017	±0.003	-
c	0.009	0.009	0.009	0.011	0.011	0.011	0.011	±0.001	-
D	0.193	0.341	0.390	0.406	0.504	0.606	0.704	±0.004	1, 3
E	0.236	0.236	0.236	0.406	0.406	0.406	0.406	±0.008	-
E1	0.154	0.154	0.154	0.295	0.295	0.295	0.295	±0.004	2, 3
e	0.050	0.050	0.050	0.050	0.050	0.050	0.050	Basic	-
L	0.025	0.025	0.025	0.030	0.030	0.030	0.030	±0.009	-
L1	0.041	0.041	0.041	0.056	0.056	0.056	0.056	Basic	-
h	0.013	0.013	0.013	0.020	0.020	0.020	0.020	Reference	-
N	8	14	16	16	20	24	28	Reference	-

Rev. M 2/07

NOTES:

1. Plastic or metal protrusions of 0.006" maximum per side are not included.
2. Plastic interlead protrusions of 0.010" maximum per side are not included.
3. Dimensions "D" and "E1" are measured at Datum Plane "H".
4. Dimensioning and tolerancing per ASME Y14.5M-1994

EL5164, EL5165, EL5364

Quarter Size Outline Plastic Packages Family (QSOP)

MDP0040

QUARTER SIZE OUTLINE PLASTIC PACKAGES FAMILY

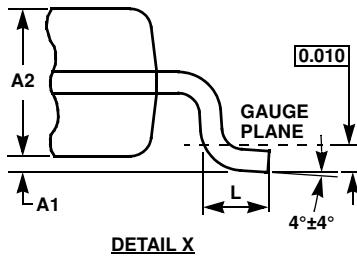
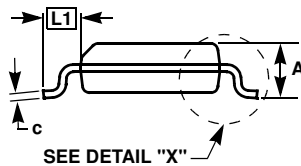
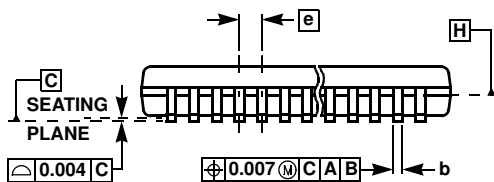
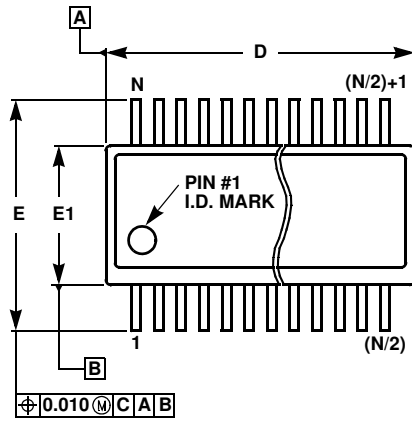

Rev. F 2/07

NOTES:

5. Plastic or metal protrusions of 0.006" maximum per side are not included.
6. Plastic interlead protrusions of 0.010" maximum per side are not included.
7. Dimensions "D" and "E1" are measured at Datum Plane "H".
8. Dimensioning and tolerancing per ASME Y14.5M-1994.

MDP0040

QUARTER SIZE OUTLINE PLASTIC PACKAGES FAMILY

SYMBOL	INCHES			TOLERANCE	NOTES
	QSOP16	QSOP24	QSOP28		
A	0.068	0.068	0.068	Max.	-
A1	0.006	0.006	0.006	±0.002	-
A2	0.056	0.056	0.056	±0.004	-
b	0.010	0.010	0.010	±0.002	-
c	0.008	0.008	0.008	±0.001	-
D	0.193	0.341	0.390	±0.004	1, 3
E	0.236	0.236	0.236	±0.008	-
E1	0.154	0.154	0.154	±0.004	2, 3
e	0.025	0.025	0.025	Basic	-