

Surface Mount Schottky Diode

BAT54 Series -G Voltage: 30 Volts Current: 200mA



Features

- Low Turn-on Voltage
- Fast Switching
- PN Junction Guard Ring for Transient and ESD Protection

Mechanical data

Case: SOT-23, Molded Plastic
 Terminals: Solderable per MIL-STD-202, Method 208
 Polarity: See Diagrams Below
 Weight: 0.008 grams (approx.)
 Mounting Position: Any

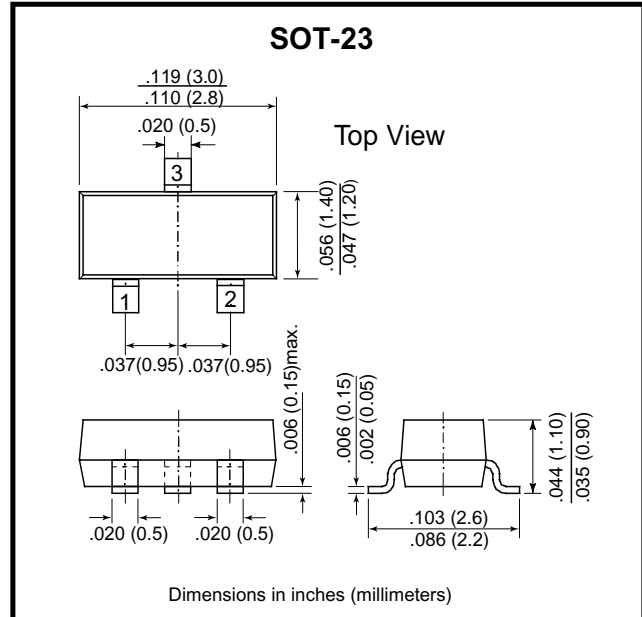
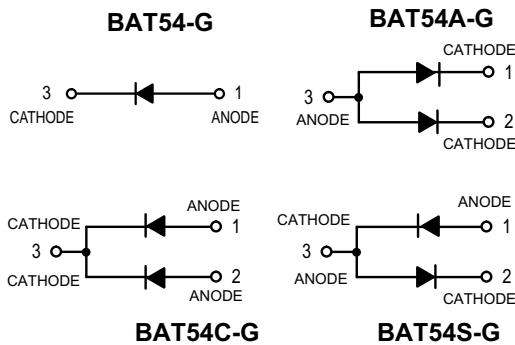

Maximum Ratings ($T_A = 125^\circ\text{C}$ unless otherwise noted)

Rating	Symbol	Value	Units
Reverse Voltage	V_R	30	Volts
Forward Power Dissipation @ $T_A = 25^\circ\text{C}$ Derate above 25°C	P_F	225 1.8	mW mW/ $^\circ\text{C}$
Forward Current (DC)	I_F	200 Max	mA
Junction Temperature	T_J	125 Max	$^\circ\text{C}$
Storage Temperature Range	T_{stg}	-55 to +150	$^\circ\text{C}$

Electrical Characteristics ($T_A = 25^\circ\text{C}$ unless otherwise noted) (EACH DIODE)

Parameter	Symbol	Min	Typ	Max	Unit
Reverse Breakdown Voltage ($I_R = 10 \text{ mA}$)	$V_{(BR)R}$	30	—	—	Volts
Total Capacitance ($V_R = 1.0 \text{ V}$, $f = 1.0 \text{ MHz}$)	C_T	—	7.60	10.0	pF
Reverse Leakage ($V_R = 25 \text{ V}$)	I_R	—	0.50	2.0	mAdc
Forward Voltage ($I_F = 0.1 \text{ mAdc}$) ($I_F = 30 \text{ mAdc}$) ($I_F = 100 \text{ mAdc}$)	V_F	—	0.22 0.41 0.52	0.24 0.5 1.0	Vdc
Reverse Recovery Time ($I_F = I_R = 10 \text{ mAdc}$, $I_R(\text{REC}) = 1.0 \text{ mAdc}$) Figure 1	t_{rr}	—	—	5.0	ns
Forward Voltage ($I_F = 1.0 \text{ mAdc}$) ($I_F = 10 \text{ mAdc}$)	V_F	—	0.29 0.35	0.32 0.40	Vdc
Forward Current (DC)	I_F	—	—	200	mAdc
Repetitive Peak Forward Current	I_{FRM}	—	—	300	mAdc
Non-Repetitive Peak Forward Current ($t < 1.0 \text{ s}$)	I_{FSM}	—	—	600	mAdc

Surface Mount Schottky Diode

RATING AND CHARACTERISTIC CURVES (BAT54 Series-G)

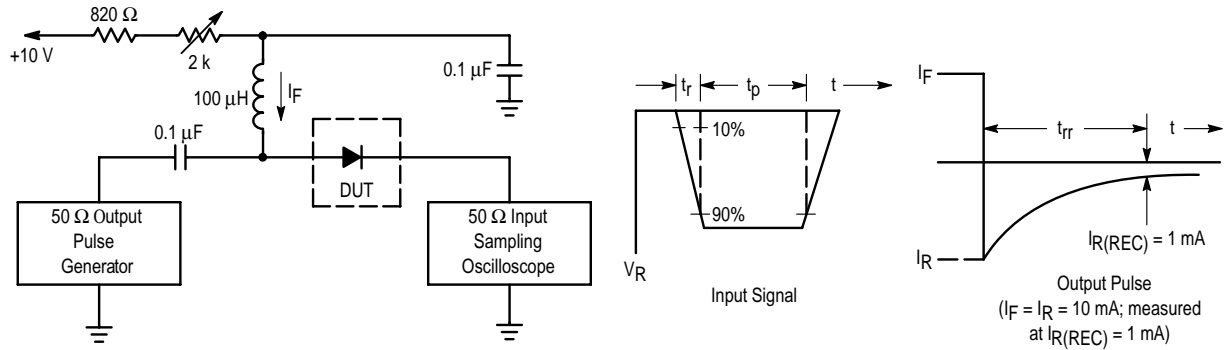

- Notes: 1. A 2.0 kΩ variable resistor adjusted for a Forward Current (I_F) of 10 mA.
 2. Input pulse is adjusted so $I_{R(peak)}$ is equal to 10 mA.
 3. $t_p \gg t_{rr}$

Figure 1. Recovery Time Equivalent Test Circuit

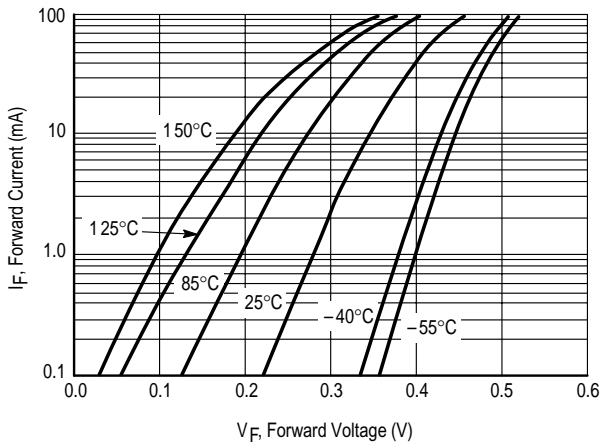

Figure 2. Forward Voltage

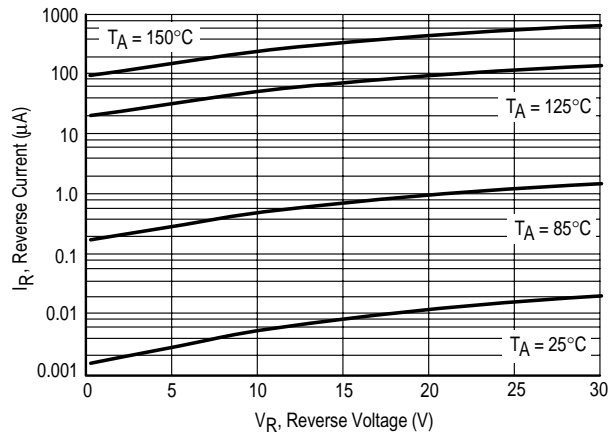

Figure 3. Leakage Current

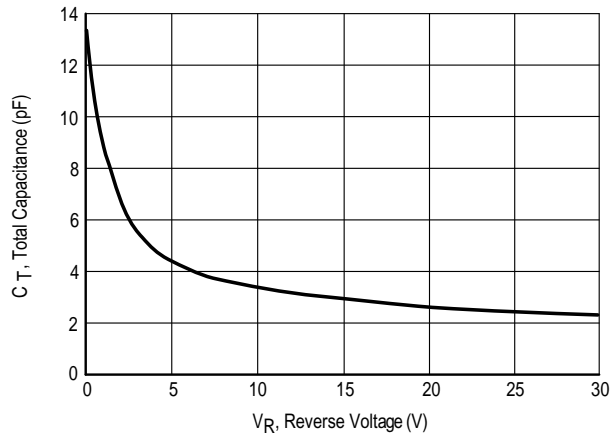

Figure 4. Total Capacitance