

STANDARD PRODUCT LABEL DESCRIPTION
 (CUSTOM AVAILABLE UPON REQUEST)

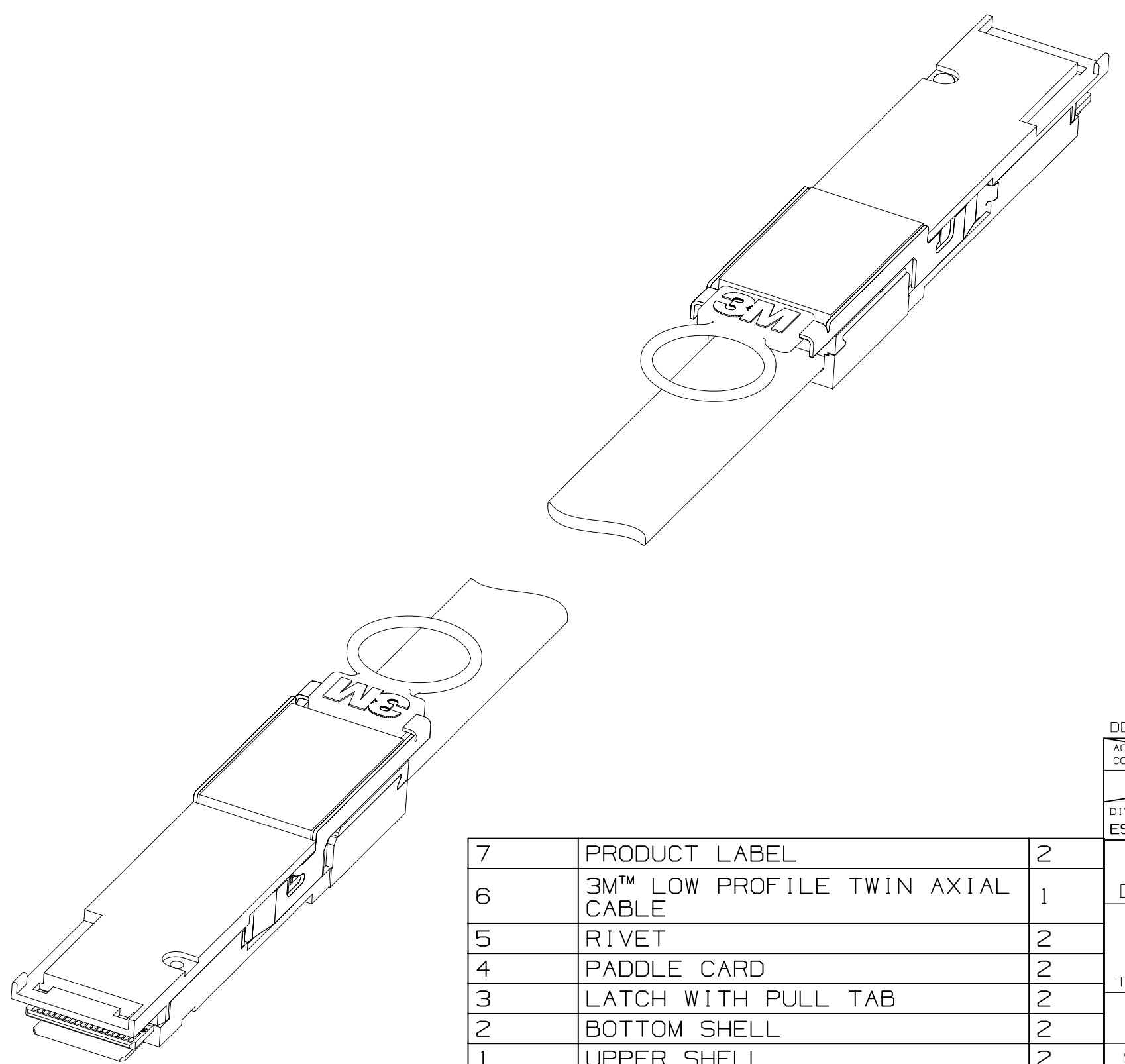

BALLOON ITEM	DESCRIPTION	QTY
7	PRODUCT LABEL	2
6	3M™ LOW PROFILE TWIN AXIAL CABLE	1
5	RIVET	2
4	PADDLE CARD	2
3	LATCH WITH PULL TAB	2
2	BOTTOM SHELL	2
1	UPPER SHELL	2

DESIGN REFERENCE	NEXT ASSEMBLY
DO NOT SCALE DRAWING	SCALE 2/1
THIRD ANGLE PROJECTION	INTERPRET PER ASME Y14.5 - 2009
MAX SURFACE ROUGHNESS 125	ALL SURFACES MARKED ONLY
TOLERANCES EXCEPT AS NOTED	MILLIMETERS: 0 ± .00, .00 ± .10, .000 ± .000, .000 ± .000
	ANGLES ± 0.5°

REV	ECO	ISSUE DATE AND DESCRIPTION	DRFT	CHKD
E 0068166		JUN 14, 2016 PG 2 OF 2: REMOVE UNWANTED WORDINGS.	RL	YL
D 0044020		OCT 24, 2012 PG 2 OF 2 LOC 7D DELETE INFOR FOR FDR & 2BAWG	OKC	RL
C 0040930		JUN 11, 2012 PG 2 OF 2 LOC A8 ADD NOTES 12 & 13 PG 1 OF 2 LOC B6 MODIFY PART NUMBER PG 2 OF 2 LOC B8 DELETE 'PRELIMINARY' PG 2 OF 2 LOC D4 MODIFY PART NUMBER PG 2 OF 2 LOC D7 ADD EEPROM MAP PG 2 OF 2 LOC C4 ADD WIRING SIGNAL LISTS	OKC	RL
B 0037834		DEC 16, 2011 PG 2 OF 2 LOC C1 DIMENSION C CHANGED TO 15.5. PG 2 OF 2 LOC D4 ORDERING NUMBERS MODIFIED. PG 2 OF 2 LOC D7 ORDERING INFORMATION MODIFIED. PG 1 OF 2 LOC A6 LABEL SERIAL NUMBER FORMAT CHANGED.	OKC	RL
A 0035856		SEP 12, 2011 NEW RELEASE	OKC	RL

REV	ECO	ISSUE DATE AND DESCRIPTION	DRFT	CHKD
DRFT	OH KIM CHYE	SEP 09, 2011	UG LIU	SEP 09, 2011
CHKD	ROY LIM	SEP 09, 2011	SAJJIT B	SEP 09, 2011

TITLE	CAGE NUMBER	SIZE	DRAWING NO.	REV.
3M™ DIRECT ATTACH COPPER QSFP+ QDR/DDR CABLE ASSY SALES DWG	D	78-5100-2439-7	E	1 OF 2

06-28-2016 10:48 78-5100-2439-7-s1dasm.prt 78-5100-2439-7 DRAWING NUMBER REVISION

NOTES:

1. ORDERING INFORMATION:

9QXX-111-XX-X.XX

ASSEMBLY LENGTH X IN METERS SEE TABLE 1

EEPROM MEMORY MAP

11= DDR (5Gbps)

12= QDR (10Gbps)

XX= CUSTOMIZATION(SEE 3M SALES REP)

AWG

0= 30 AWG

CABLE TYPE

A= 30AWG(PVC)

2. REFER TO TABLE 1 FOR CABLE LENGTH, WIDTH, THICKNESS AND WIRE AWG

3. MODULE PCB PINOUT PER SFF8436 SPECIFICATION

4. SFF 8436 QSFP+ MODULE HOUSING: ZINC ALLOY WITH NICKEL PLATING

5. JACKET: BLACK PVC .015" NOMINAL THICKNESS

6. CABLE UL TEMPERATURE RATING -20C TO +80C

7. FOLDING BEND RADIUS 2.5mm

8. SEE REGULATORY INFORMATION APPENDIX (RIA) AT 3Mconnectors.com FOR RoHS COMPLIANCE INFORMATION (RIA E1 and C1 apply)

9. STANDARD PRODUCT SPECIFICATION: 78-5102-0097-1 A

10. FOR CUSTOM LENGTHS CONTACT A 3M SALES REPRESENTATIVE

TABLE 1

ORDERING INFORMATION	ASSY LENGTH=X (m)	TOLERANCE (mm)	B NOMINAL (mm)	C NOMINAL (mm)
9QA0-111-12-0.50 *	0.50	+10 / - 0	1.95	15.5
9QA0-111-12-0.75	0.75			
9QA0-111-12-1.00 *	1.00			
9QA0-111-12-1.10	1.10			
9QA0-111-12-1.50	1.50			
9QA0-111-12-2.00 *	2.00			
9QA0-111-12-2.50	2.50			
9QA0-111-12-3.00 *	3.00			
9QA0-111-11-3.50 **	3.50	+50 / - 0		
9QA0-111-XX-3.50				
9QA0-111-11-4.00 **	4.00	+80 / - 0		
9QA0-111-XX-4.00				
9QA0-111-11-5.00 **	5.00	+80 / - 0		
9QA0-111-XX-5.00				

WIRING LIST

P1 END		P2 END	
POS	SIGNAL	POS	SIGNAL
1	GND (TX)	20	GND (RX)
2	TX2n	21	RX2n
3	TX2P	22	RX2p
4	GND (TX)	23	GND (RX)
5	TX4n	24	RX4n
6	TX4P	25	RX4p
7	GND (TX)	26	GND (RX)
13	GND (RX)	32	GND (TX)
14	RX3p	33	TX3p
15	RX3n	34	TX3n
16	GND (RX)	35	GND (TX)
17	RX1p	36	TX1p
18	RX1n	37	TX1n
19	GND (RX)	38	GND (TX)
20	GND (RX)	1	GND (TX)
21	RX2n	2	TX2n
22	RX2p	3	TX2P
23	GND (RX)	4	GND (TX)
24	RX4n	5	TX4n
25	RX4p	6	TX4P
26	GND (RX)	7	GND (TX)
32	GND (TX)	13	GND (RX)
33	TX3p	14	RX3p
34	TX3n	15	RX3n
35	GND (TX)	16	GND (RX)
36	TX1p	17	RX1p
37	TX1n	18	RX1n
38	GND (TX)	19	GND (RX)

LOW SPEED SIGNALS

P1 & P2	
POS	SIGNAL
8	ModSelL
9	ResetL
10	VccRx
11	SCL
12	SDA
27	ModPrsL
28	IntL
29	VccTx
30	VccI
31	LPMODE

REV	ECO	ISSUE DATE AND DESCRIPTION	DRFT	CHKD
E 0068166		JUN 14, 2016 PG 2 OF 2: REMOVE UNWANTED WORDINGS.	RL	YL
D 0044020		OCT 24, 2012 PG 2 OF 2 LOC 7D DELETE INFOR FOR FDR & 28AWG	OKC	RL
C 0040930		JUN 11, 2012 PG 2 OF 2 LOC A8 ADD NOTES 12 & 13 PG 1 OF 2 LOC B6 MODIFY PART NUMBER PG 2 OF 2 LOC B8 DELETE 'PRELIMINARY' PG 2 OF 2 LOC D4 MODIFY PART NUMBER PG 2 OF 2 LOC D7 ADD EEPROM MAP PG 2 OF 2 LOC C4 ADD WIRING SIGNAL LISTS	OKC	RL
B 0037834		DEC 16, 2011 PG 2 OF 2 LOC C1 DIMENSION C CHANGED TO 15.5. PG 2 OF 2 LOC D4 ORDERING NUMBERS MODIFIED. PG 2 OF 2 LOC D7 ORDERING INFORMATION MODIFIED. PG 1 OF 2 LOC A6 LABEL SERIAL NUMBER FORMAT CHANGED.	OKC	RL
A 0035856		SEP 12, 2011 NEW RELEASE	OKC	RL

DESIGN REFERENCE	NEXT ASSEMBLY	REV	ECO	ISSUE DATE AND DESCRIPTION	DRFT	CHKD
		01		09, 2011		
DO NOT SCALE DRAWING	SCALE 2/1	DRFT	01	09, 2011		
THIRD ANGLE PROJECTION	TOLERANCES EXCEPT AS NOTED	CHKD	01	09, 2011		
INTERPRET PER ASME Y14.5 - 2009	TOLERANCES EXCEPT AS NOTED	APPR	01	09, 2011		
MAX SURFACE ROUGHNESS 125	MILLIMETERS 0 ± .2					
ALL SURFACES MARKED ONLY	ANGLES ±0.5°					
<p>3M™ DIRECT ATTACH COPPER QSFP+ QDR/DDR CABLE ASSY SALES DWG</p>		CAGE NUMBER	SIZE	DRAWING NO.	REV.	
		D		78-5100-2439-7	E	
		MODEL				

78-5100-2439-7 10148 06-28-2016 10148 78-5100-2439-7_s1dasm.prt