

THIS DRAWING IS UNPUBLISHED  
 RELEASED FOR PUBLICATION  
 © COPYRIGHT 20 BY - ALL RIGHTS RESERVED.

REVISIONS					
P	LTR	DESCRIPTION	DATE	DWN	APVD
C	I	REVISED PER ECO-11-005294	21APR2011	RK	HMR
D	D	REVISED PER ECO-13-019231	09DEC2013	DR	RB

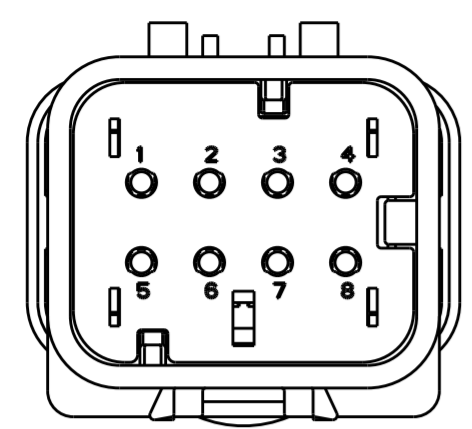

776495-2  
SCALE 2:1

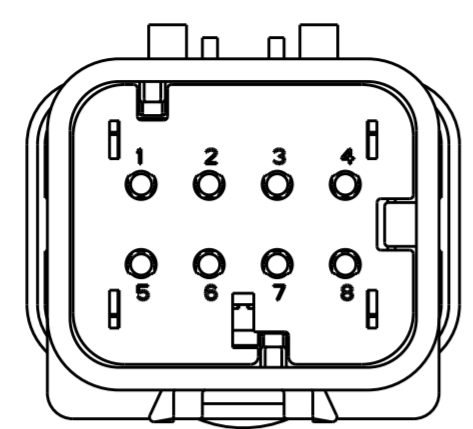

776495-3  
SCALE 2:1

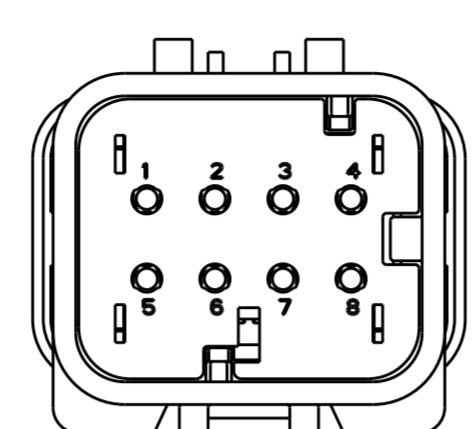

776495-4  
SCALE 2:1

- ① MATERIAL: 15% GLASS FILLED THERMOPLASTIC  
COLOR: BLACK
- ② MATERIAL: 15% GLASS FILLED THERMOPLASTIC  
COLOR: (SEE TABLE)
- ③ MATERIAL: SILICONE  
COLOR: GREEN

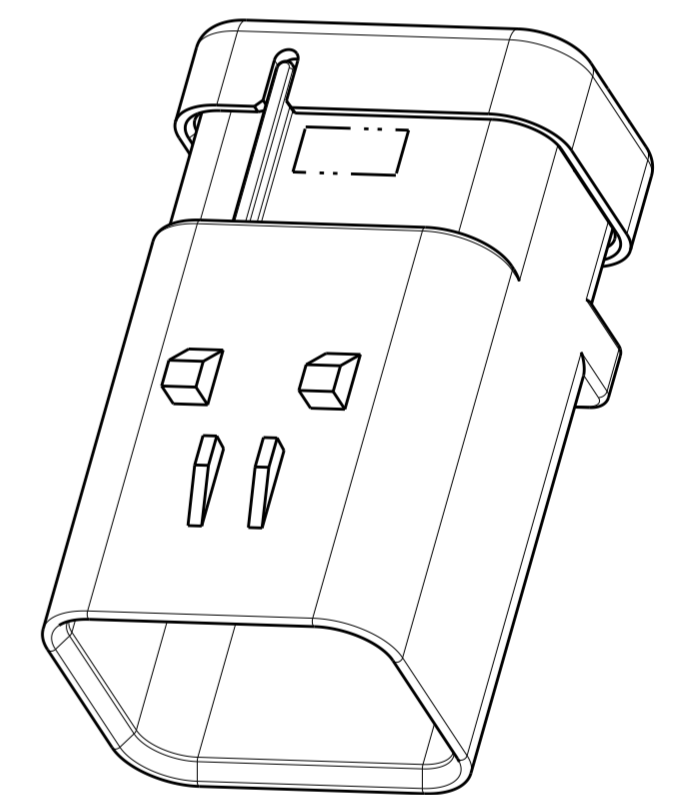
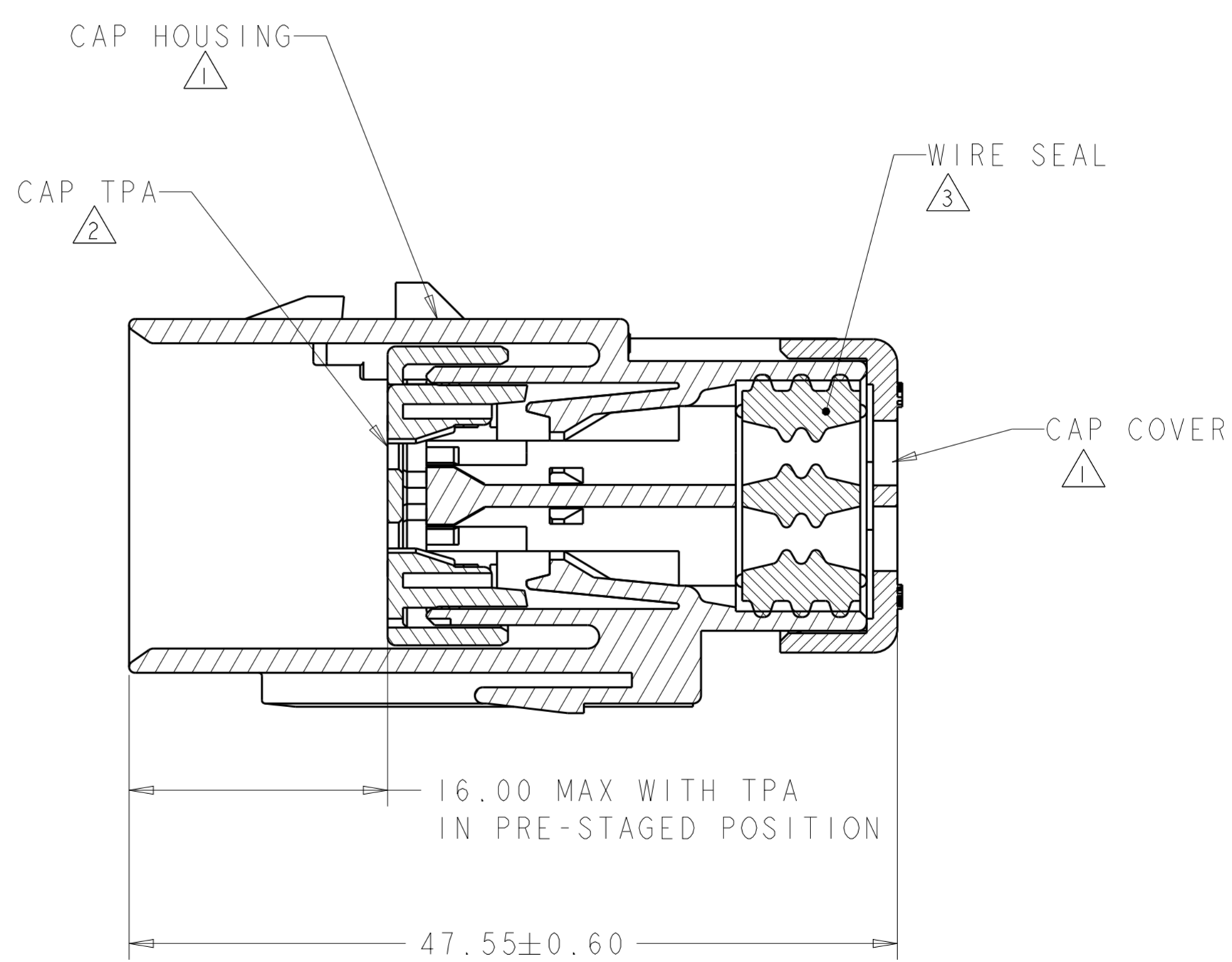
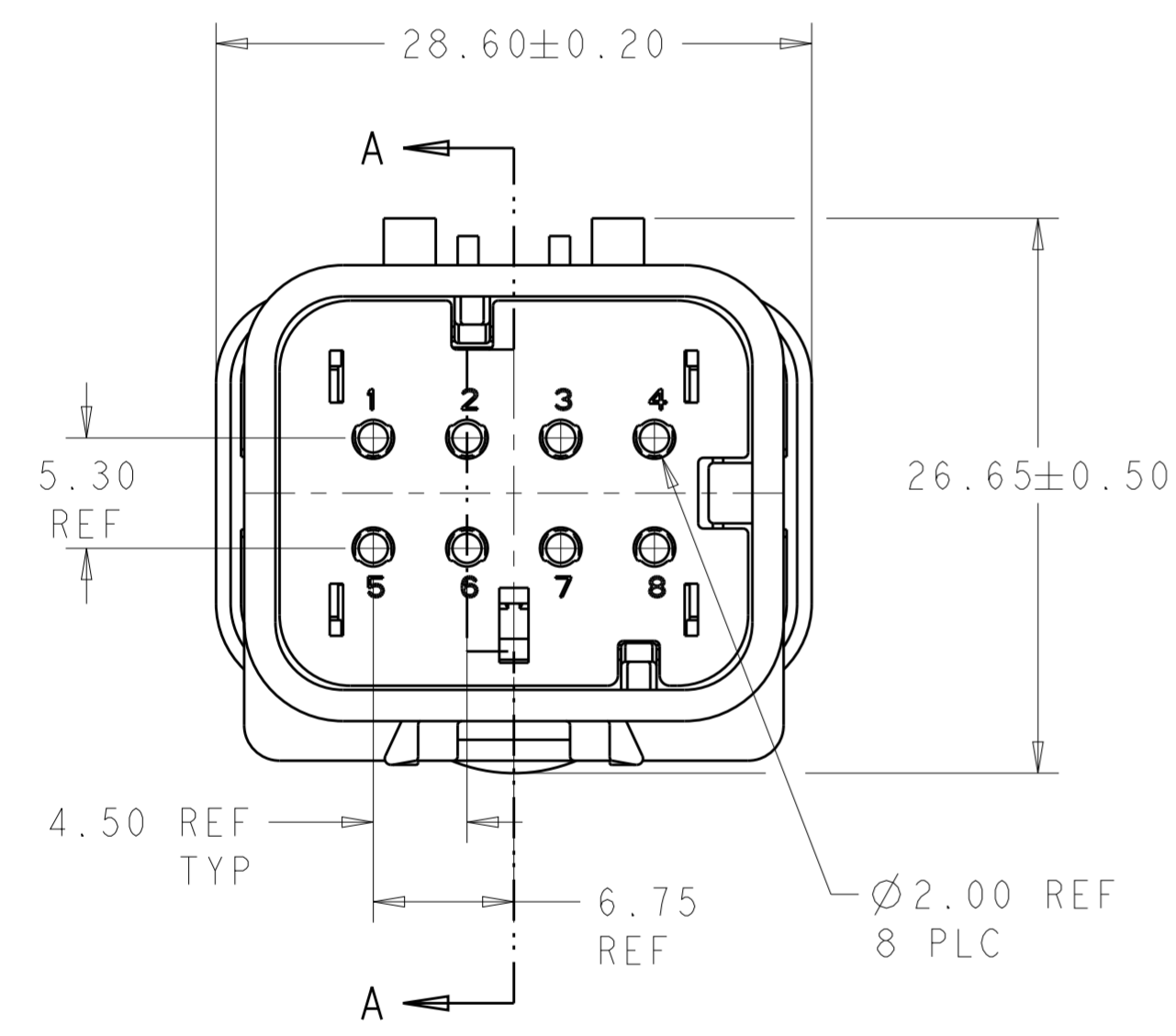

SCALE 2:1

TPA COLOR	PART NUMBER
GREEN	776495-4
YELLOW	776495-3
GRAY	776495-2
RED	776495-1

THIS DRAWING IS A CONTROLLED DOCUMENT.		DWN Y. PETERSON 17DEC02	TE Connectivity	
DIMENSIONS: mm		CHK R. GREINER 17DEC02		
TOLERANCES UNLESS OTHERWISE SPECIFIED:		APVD R. GREINER 17DEC02		
0 PLC ± 1 PLC ± 2 PLC ± 3 PLC ± 4 PLC ± ANGLES ± FINISH -		PRODUCT SPEC 108-2184 APPLICATION SPEC 114-13065 WEIGHT 17.5 ± 1g		
MATERIAL		Customer Drawing	NAME CAP ASSEMBLY, 8 POSITION, DUAL ROW, AMPSEAL 16	RESTRICTED TO
		SIZE A2	CAGE CODE -	DRAWING NO G-776495
		SCALE 2:1	SHEET 1	REV D