

REVISIONS

P	LTR	DESCRIPTION	DATE	DWN	APVD
	F4	REVISED PER ECN-22-150900	28APR2022	RK	CSD

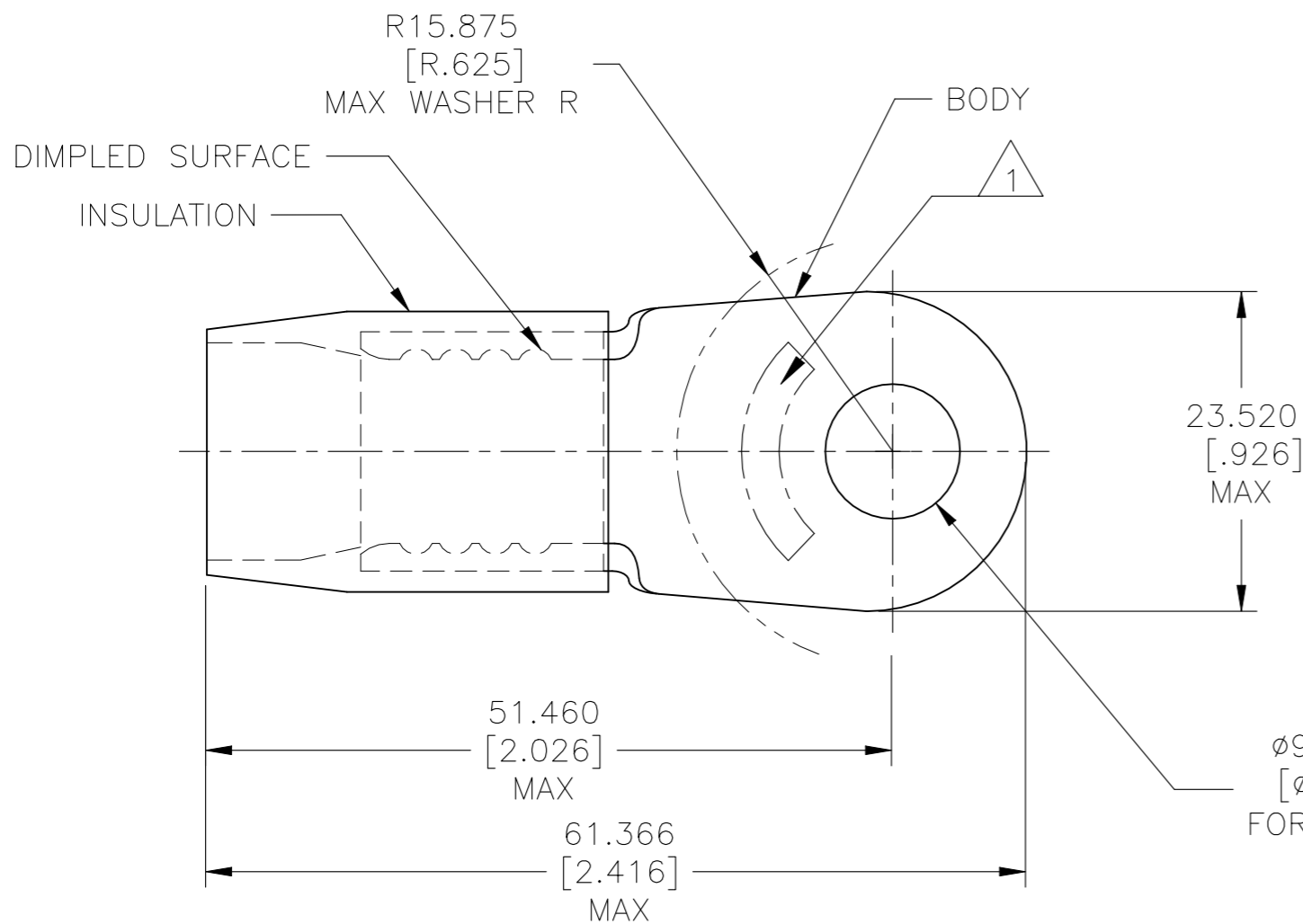

AMP WIRE RANGE
2/0 AWG STRANDED

- △1 STAMP AMP 2/0 W*, LOCATE APPROX AS SHOWN.
- 2 BODY MATERIAL THK 2.032±0.051 [.080±.002]
- 3 WIRE INSULATION ø15.494 [ø.610] MAX.
- △4 BODY: COPPER PER ASTM B-152
INSULATION: NYLON ASTM D4066 TYPE I.
- △5 BODY: TIN PLATED PER ASTM B-545
INSULATION: COLOR-YELLOW.

50	LOOSE PC	324084
QTY	PACKAGE TYPE	PART NO

MAX RECOMMENDED OPERATING TEMPERATURE: 105°C[221°F]	THIS DRAWING IS A CONTROLLED DOCUMENT.		DWN S.S. GOULDEN 9-28-93	STE TE Connectivity		
	VOLTAGE RATING: -	DIMENSIONS: mm [INCHES]	TOLERANCES UNLESS OTHERWISE SPECIFIED:			
CIRCULAR MIL AREA: 60.6-76.3mm ² [119,500-150,500] STRANDED	MATERIAL △4	FINISH △5	APVD M ELLIS 9-28-93	NAME TERMINAL, RING TONGUE, TERMINYL, WIRE SIZE: 2/0 AWG		
			PRODUCT SPEC	APPLICATION SPEC	SIZE	CAGE CODE
			WEIGHT	A3	00779	C-324084
			CUSTOMER DRAWING	SCALE	NTS	SHEET 1 OF 1
						REV F4