

Programmable Timing Control Hub™ for P4™

Recommended Application:

Brookdale and Brookdale -G chipset with P4 processor.

Output Features:

- 3 - Pairs of differential CPU clocks (differential current mode)
- 5 - 3V66 @ 3.3V
- 10 - PCI @ 3.3V
- 2 - 48MHz @ 3.3V fixed
- 1 - REF @ 3.3V, 14.318MHz
- 1 - VCH/3V66 @ 3.3V, 48 MHz or 66.6 MHz

Features/Benefits:

- Programmable output frequency.
- Programmable output divider ratios.
- Programmable output rise/fall time.
- Programmable output skew.
- Programmable spread percentage for EMI control.
- Watchdog timer technology to reset system if system malfunctions.
- Programmable spread percentage for EMI control.
- Watchdog timer technology to reset system if system malfunctions.
- Programmable watch dog safe frequency.
- Support I²C Index read/write and block read/write operations.
- Uses external 14.318MHz crystal.

Key Specifications:

- CPU Output Jitter <150ps
- 3V66 Output Jitter <250ps
- CPU Output Skew <100ps

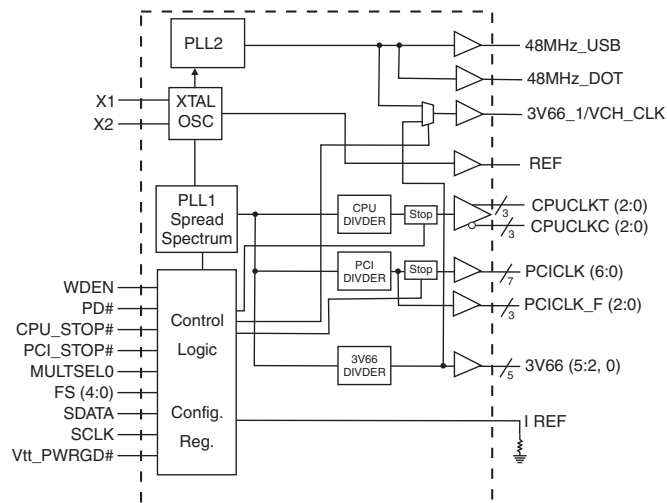
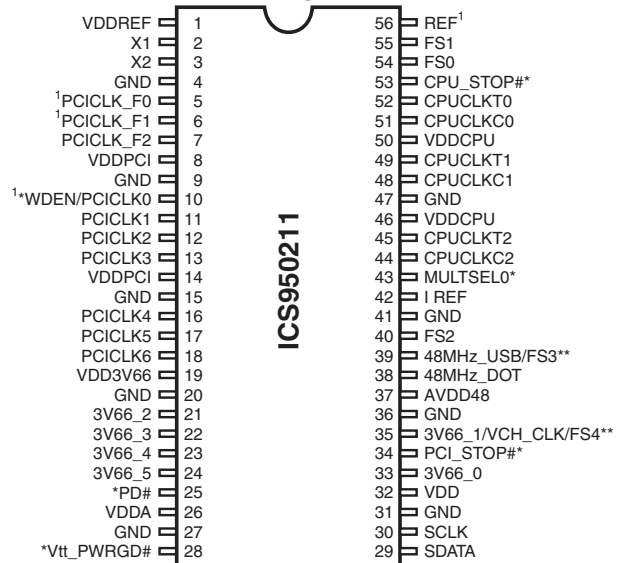
Block Diagram

Pin Configuration

56-Pin 300-mil SSOP & 240-mil TSSOP

1. These outputs have 2X drive strength.

* Internal Pull-up resistor of 120K to VDD

** these inputs have 120K internal pull-down to GND

Frequency Table

FS4	FS3	FS2	FS1	FS0	CPUCLK MHz	3V66 MHz	PCICLK MHz
0	0	0	0	0	66.66*	66.66	33.33
0	0	0	0	1	100.00	66.66	33.33
0	0	0	1	0	200.00	66.66	33.33
0	0	0	1	1	133.33	66.66	33.33
0	0	1	0	0	100.90	67.27	33.63
0	0	1	0	1	105.00	70.00	35.00
0	0	1	1	0	109.00	72.67	36.33
0	0	1	1	1	114.00	76.00	38.00
0	1	0	0	0	117.00	78.00	39.00
0	1	0	0	1	127.00	72.86	36.43
0	1	0	1	0	130.00	74.29	37.14
0	1	0	1	1	132.50	75.71	37.89
0	1	1	0	0	205.00	70.00	35.00
0	1	1	0	1	170.00	56.67	28.33
0	1	1	1	0	180.00	60.00	30.00
0	1	1	1	1	190.00	63.33	31.67

For additional frequency selections please refer to Byte 0.

* For 950211BF version, this frequency is 166.66MHz.

Power Groups

VDDA = Analog Core PLL

VDDREF = REF, Xtal

AVDD48 = 48MHz

General Description

The **ICS950211** is a single chip clock solution for desktop designs using the Intel Brookdale chipset with PC133 or DDR memory. It provides all necessary clock signals for such a system.

The **ICS950211** is part of a whole new line of ICS clock generators and buffers called TCH™ (Timing Control Hub). This part incorporates ICS's newest clock technology which offers more robust features and functionality. Employing the use of a serially programmable I²C interface, this device can adjust the output clocks by configuring the frequency setting, the output divider ratios, selecting the ideal spread percentage, the output skew, the output strength, and enabling/disabling each individual output clock. M/N control can configure output frequency with resolution up to 0.1MHz increment.

Pin Description

PIN NUMBER	PIN NAME	TYPE	DESCRIPTION
1, 8, 14, 19, 32, 46, 50	VDD	PWR	3.3V power supply.
2	X1	IN	Crystal input, has internal load cap (33pF) and feedback resistor from X2.
3	X2	OUT	Crystal output, nominally 14.318MHz. Has internal load cap (33pF).
4, 9, 15, 20, 27, 31, 36, 41, 47	GND	PWR	Ground pins for 3.3V supply.
24, 23, 22, 21, 33	3V66 (5:2, 0)	OUT	3.3V Fixed 66MHz clock outputs for HUB.
7,6,5	PCICLK_F(2:0)	OUT	3.3V PCI clock output
10	WDEN	IN	Hardware enable of watch dog circuit. Enabled when latched high.
	PCICLK0	OUT	3.3V PCI clock output.
18, 17, 16, 13, 12, 11	PCICLK (6:1)	OUT	3.3V PCI clock outputs.
25	PD#	IN	Asynchronous active low input pin used to power down the device into a low power state. The internal clocks are disabled and the VCO and the crystal are stopped. The latency of the power down will not be greater than 3ms.
26	VDDA	PWR	Analog power 3.3V.
28	Vt_PWRGD#	IN	This 3.3V LVTTTL input is a level sensitive strobe used to determine when FS (4:0) inputs are valid and are ready to be sampled (active low).
30	SCLK	IN	Clock pin for I ² C circuitry 5V tolerant.
29	SDATA	I/O	Data pin for I ² C circuitry 5V tolerant.
34	PCI_STOP#	IN	Halts PCICLK clocks at logic 0 level, when input low except PCICLK_F which are free running.
35	3V66_1/VCH_CLK	OUT	3.3V output selectable through I ² C to be 66MHz from internal VCO or 48MHz (non-SSC).
	FS4	IN	Logic input frequency select bit. Input latched at power on.
37	AVDD48	PWR	Analog power 3.3V.
38	48MHz_DOT	OUT	3.3V Fixed 48MHz clock output for DOT.
39	FS3	IN	Logic input frequency select bit. Input latched at power on.
	48MHz_USB	OUT	3.3V Fixed 48MHz clock output for USB.
42	I REF	OUT	This pin establishes the reference current for the CPUCLK pairs. This pin requires a fixed precision resistor tied to ground in order to establish the appropriate current.
43	MULTSEL0	IN	3.3V LVTTTL input for selecting the current multiplier for CPU outputs
44, 48, 51	CPUCLKC (2:0)	OUT	"Complementary" clocks of differential pair CPU outputs. These are current outputs and external resistors are required for voltage bias.
45, 49, 52	CPUCLKT (2:0)	OUT	"True" clocks of differential pair CPU outputs. These are current outputs and external resistors are required for voltage bias.
40, 55, 54	FS (2:0)	IN	Logic input frequency select bit. Input latched at power on.
53	CPU_STOP#	IN	Halts CPUCLK clocks at logic 0 level, when input low except CPUCLK_F which are free running.
56	REF	OUT	3.3V, 14.318MHz reference clock output.

Maximum Allowed Current

Condition	Max 3.3V supply consumption Max discrete cap loads, Vdd = 3.465V All static inputs = Vdd or GND
Powerdown Mode (PWRDWN# = 0)	40mA
Full Active	360mA

Host Swing Select Functions

MULTISELO	Board Target Trace/Term Z	Reference R, Iref = $V_{DD}/(3 \cdot R_r)$	Output Current	Voh @ Z
0	50 ohms	Rr = 221 1%, Iref = 5.00mA	Ioh = 4 * I REF	1.0V @ 50
1	50 ohms	Rr = 475 1%, Iref = 2.32mA	Ioh = 6 * I REF	0.7V @ 50

General I²C serial interface information

How to Write:

- Controller (host) sends a start bit.
- Controller (host) sends the write address D2_(H)
- ICS clock will **acknowledge**
- Controller (host) sends the beginning byte location = N
- ICS clock will **acknowledge**
- Controller (host) sends the data byte count = X
- ICS clock will **acknowledge**
- Controller (host) starts sending **Byte N through Byte N + X - 1**
(see Note 2)
- ICS clock will **acknowledge** each byte **one at a time**
- Controller (host) sends a Stop bit

How to Read:

- Controller (host) will send start bit.
- Controller (host) sends the write address D2_(H)
- ICS clock will **acknowledge**
- Controller (host) sends the beginning byte location = N
- ICS clock will **acknowledge**
- Controller (host) will send a separate start bit.
- Controller (host) sends the read address D3_(H)
- ICS clock will **acknowledge**
- ICS clock will send the data byte count = X
- ICS clock sends **Byte N + X - 1**
- ICS clock sends **Byte 0 through byte X (if X_(H) was written to byte 8).**
- Controller (host) will need to acknowledge each byte
- Controller (host) will send a not acknowledge bit
- Controller (host) will send a stop bit

Index Block Write Operation		
Controller (Host)		ICS (Slave/Receiver)
T	starT bit	
Slave Address D2 _(H)		
WR	WRite	
		ACK
Beginning Byte = N		
		ACK
Data Byte Count = X		
		ACK
Beginning Byte N		X Byte
○		
○		
○		
Byte N + X - 1		
		ACK
P	stoP bit	

Index Block Read Operation		
Controller (Host)		ICS (Slave/Receiver)
T	starT bit	
Slave Address D2 _(H)		
WR	WRite	
		ACK
Beginning Byte = N		
		ACK
RT	Repeat starT	
Slave Address D3 _(H)		
RD	ReaD	
		ACK
		Data Byte Count = X
ACK		
ACK		X Byte
○		
○		
○		
		Byte N + X - 1
N	Not acknowledge	
P	stoP bit	

*See notes on the following page.

0465E—05/17/05

Byte 0: Functionality and frequency select register (Default=0)

Bit	Description									PWD	
	Bit2	Bit7	Bit6	Bit5	Bit4	CPUCLK MHz	3V66 MHz	PCICLK MHz	Spread %		
Bit (2,7:4)	FS4	FS3	FS2	FS1	FS0						Note 1
	0	0	0	0	0	66.66 ²	66.66	33.33	0 to -0.5% down spread		
	0	0	0	0	1	100.00	66.66	33.33	0 to -0.5% down spread		
	0	0	0	1	0	200.00	66.66	33.33	0 to -0.5% down spread		
	0	0	0	1	1	133.33	66.66	33.33	0 to -0.5% down spread		
	0	0	1	0	0	100.90	67.27	33.63	+/-0.35% center spread		
	0	0	1	0	1	105.00	70.00	35.00	+/-0.35% center spread		
	0	0	1	1	0	109.00	72.67	36.33	+/-0.35% center spread		
	0	0	1	1	1	114.00	76.00	38.00	+/-0.35% center spread		
	0	1	0	0	0	117.00	78.00	39.00	+/-0.35% center spread		
	0	1	0	0	1	127.00	72.86	36.43	+/-0.35% center spread		
	0	1	0	1	0	130.00	74.29	37.14	+/-0.35% center spread		
	0	1	0	1	1	132.50	75.71	37.89	+/-0.35% center spread		
	0	1	1	0	0	205.00	70.00	35.00	+/-0.35% center spread		
	0	1	1	0	1	170.00	56.67	28.33	+/-0.35% center spread		
	0	1	1	1	0	180.00	60.00	30.00	+/-0.35% center spread		
	0	1	1	1	1	190.00	63.33	31.67	+/-0.35% center spread		
	1	0	0	0	0	133.90	66.95	33.48	+/-0.35% center spread		
	1	0	0	0	1	133.33	66.67	33.33	+/-0.35% center spread		
	1	0	0	1	0	120.00	60.00	30.00	+/-0.35% center spread		
	1	0	0	1	1	125.00	62.50	31.25	+/-0.35% center spread		
	1	0	1	0	0	134.90	67.45	33.73	+/-0.35% center spread		
	1	0	1	0	1	137.00	68.50	34.25	+/-0.35% center spread		
	1	0	1	1	0	139.00	69.50	34.75	+/-0.35% center spread		
	1	0	1	1	1	141.00	70.50	35.25	+/-0.35% center spread		
	1	1	0	0	0	143.00	71.50	35.75	+/-0.35% center spread		
	1	1	0	0	1	145.00	72.50	36.25	+/-0.35% center spread		
	1	1	0	1	0	150.00	75.00	37.50	+/-0.35% center spread		
1	1	0	1	1	155.00	77.50	38.75	+/-0.35% center spread			
1	1	1	0	0	160.00	80.00	40.00	+/-0.35% center spread			
1	1	1	0	1	150.00	64.29	32.14	+/-0.35% center spread			
1	1	1	1	0	160.00	68.57	34.29	+/-0.35% center spread			
1	1	1	1	1	170.00	72.86	36.43	+/-0.35% center spread			
Bit 3	0 - Frequency is selected by hardware select, latched inputs 1 - Frequency is selected by Bit 2,7:4									0	
Bit 1	0 - Normal 1 - Spread spectrum enable									1	
Bit 0	0 - Watch dog safe frequency will be selected by latch inputs 1 - Watch dog safe frequency will be programmed by Byte 10 bit (4:0)									0	

Notes:

1. Default at power-up will be for latched logic inputs to define frequency, as displayed by Bit 3.
2. For 950211BF version, this frequency is 166.66MHz.

Byte 1: Output Control Register
(1 = enable, 0 = disable)

Bit	Pin#	PWD	Description
Bit7	44, 45	1	CPUT/C2
Bit6	48, 49	1	CPUT/C1
Bit5	51, 52	1	CPUT/C0
Bit4	-	X	FS4 Read back
Bit3	-	X	FS3 Read back
Bit2	-	X	FS2 Read back
Bit1	-	X	FS1 Read back
Bit0	-	X	FS0 Read back

Byte 2: Output Control Register
(1 = enable, 0 = disable)

Bit	Pin#	PWD	Description
Bit7	-	X	MULTSEL (Read back)
Bit6	18	1	PCICLK_6
Bit5	17	1	PCICLK_5
Bit4	16	1	PCICLK_4
Bit3	13	1	PCICLK_3
Bit2	12	1	PCICLK_2
Bit1	11	1	PCICLK_1
Bit0	10	1	PCICLK_0

Byte 3: Output Control Register
(1 = enable, 0 = disable)

Bit	Pin#	PWD	Description
Bit7	38	1	48MHZ_DOT
Bit6	39	1	48MHz_USB
Bit5	-	1	Reset gear shift detect 1 = Enable, 0 = Disable
Bit4	-	0	Async freq. control bit 0 (See Async Freq. Control Table)
Bit3	35	0	3V66_1/VCH_CLK, (default) = 66.66MHz, 1=48MHz
Bit2	7	1	PCICLK_F2
Bit1	6	1	PCICLK_F1
Bit0	5	1	PCICLK_F0

Byte 4: Output Control Register
(1 = enable, 0 = disable)

Bit	Pin#	PWD	Description
Bit 7	-	1	Async. freq. control bit 1 (See Async. Freq. Control Table)
Bit 6	-	X	Reserved
Bit 5	33	1	3V66_0
Bit 4	35	1	3V66_1/VCH_CLK
Bit 3	24	1	3V66_5
Bit 2	23	1	3V66_4
Bit 1	22	1	3V66_3
Bit 0	21	1	3V66_2

Notes:

1. PWD = Power on Default
2. For disabled clocks, they stop low for single ended clocks. Differential CPU clocks stop with CPUCLKT at high, CPUCLKC off, and external resistor termination will bring CPUCLKC low.

Asynchronous Frequency Control Table

Byte 4	Byte 3	3V66 [0:3]	PCI_F [1:2] PCICK [0:6]	Note
Bit 7	Bit 4			
0	0	66.01 MHz	33.005 MHz	From Fix PLL (no spread)
0	1	75.44 MHz	37.72 MHz	From Fix PLL (no spread)
1	0	66.66 MHz	33.33 MHz	From main PLL (Default)
1	1	88.01 MHz	44.005 MHz	From Fix PLL (no spread)

Byte 5: Programming Edge Rate (1 = enable, 0 = disable)

Bit	Pin#	PWD	Description
Bit 7	X	1	CPUCLK T/C0 Free Running Control, 0=Free Running; 1=Stoppable*
Bit 6	X	1	CPUCLK T/C1 Free Running Control, 0=Free Running; 1=Stoppable*
Bit 5	X	1	CPUCLK T/C2 Free Running Control, 0=Free Running; 1=Stoppable*
Bit 4	X	1	(Reserved)
Bit 3	X	1	(Reserved)
Bit 2	X	1	(Reserved)
Bit 1	X	1	(Reserved)
Bit 0	X	1	(Reserved)

* This functionality is only available in BF version.

Byte 6: Vendor ID Register (1 = enable, 0 = disable)

Bit	Name	PWD	Description
Bit 7	Revision ID Bit3	X	Revision ID values will be based on individual device's revision
Bit 6	Revision ID Bit2	X	
Bit 5	Revision ID Bit1	X	
Bit 4	Revision ID Bit0	X	
Bit 3	Vendor ID Bit3	0	(Reserved)
Bit 2	Vendor ID Bit2	0	(Reserved)
Bit 1	Vendor ID Bit1	0	(Reserved)
Bit 0	Vendor ID Bit0	1	(Reserved)

Byte 7: Revision ID and Device ID Register

Bit	Name	PWD	Description
Bit 7	Device ID7	0	Device ID values will be based on individual device "01H" in this case.
Bit 6	Device ID6	0	
Bit 5	Device ID5	0	
Bit 4	Device ID4	0	
Bit 3	Device ID3	0	
Bit 2	Device ID2	0	
Bit 1	Device ID1	0	
Bit 0	Device ID0	1	

Byte 8: Byte Count Read Back Register

Bit	Name	PWD	Description
Bit 7	Byte7	0	Note: Writing to this register will configure byte count and how many bytes will be read back, default is 0F _H = 15 bytes.
Bit 6	Byte6	0	
Bit 5	Byte5	0	
Bit 4	Byte4	0	
Bit 3	Byte3	1	
Bit 2	Byte2	1	
Bit 1	Byte1	1	
Bit 0	Byte0	1	

Byte 9: Watchdog Timer Count Register

Bit	Name	PWD	Description
Bit 7	WD7	0	The decimal representation of these 8 bits correspond to X • 290ms the watchdog timer will wait before it goes to alarm mode and reset the frequency to the safe setting. Default at power up is 8 • 290ms = 2.3 seconds.
Bit 6	WD6	0	
Bit 5	WD5	0	
Bit 4	WD4	0	
Bit 3	WD3	1	
Bit 2	WD2	0	
Bit 1	WD1	0	
Bit 0	WD0	0	

Byte 10: Programming Enable bit 8 Watchdog Control Register

Bit	Name	PWD	Description
Bit 7	Program Enable	0	Programming Enable bit 0 = no programming. Frequencies are selected by HW latches or Byte0 1 = enable all I ² C programming.
Bit 6	WD Enable	0	Watchdog Enable bit. This bit will over write WDEN latched value. 0 = disable, 1 = Enable.
Bit 5	WD Alarm	0	Watchdog Alarm Status 0 = normal 1 = alarm status
Bit 4	SF4	0	Watchdog safe frequency bits. Writing to these bits will configure the safe frequency corresponding to Byte 0 Bit 2, 7:4 table
Bit 3	SF3	0	
Bit 2	SF2	0	
Bit 1	SF1	0	
Bit 0	SF0	0	

Byte 11: VCO Frequency M Divider (Reference divider) Control Register

Bit	Name	PWD	Description
Bit 7	Ndiv 8	X	N divider bit 8
Bit 6	Mdiv 6	X	The decimal representation of Mdiv (6:0) correspond to the reference divider value. Default at power up is equal to the latched inputs selection.
Bit 5	Mdiv 5	X	
Bit 4	Mdiv 4	X	
Bit 3	Mdiv 3	X	
Bit 2	Mdiv 2	X	
Bit 1	Mdiv 1	X	
Bit 0	Mdiv 0	X	

Byte 12: VCO Frequency N Divider (VCO divider) Control Register

Bit	Name	PWD	Description
Bit 7	Ndiv 7	X	The decimal representation of Ndiv (8:0) correspond to the VCO divider value. Default at power up is equal to the latched inputs selector. Notice Ndiv 8 is located in Byte 11.
Bit 6	Ndiv 6	X	
Bit 5	Ndiv 5	X	
Bit 4	Ndiv 4	X	
Bit 3	Ndiv 3	X	
Bit 2	Ndiv 2	X	
Bit 1	Ndiv 1	X	
Bit 0	Ndiv 0	X	

Byte 13: Spread Spectrum Control Register

Bit	Name	PWD	Description
Bit 7	SS 7	X	The Spread Spectrum (12:0) bit will program the spread percentage. Spread percent needs to be calculated based on the VCO frequency, spreading profile, spreading amount and spread frequency. Default power on is latched FS divider.
Bit 6	SS 6	X	
Bit 5	SS 5	X	
Bit 4	SS 4	X	
Bit 3	SS 3	X	
Bit 2	SS 2	X	
Bit 1	SS 1	X	
Bit 0	SS 0	X	

Byte 14: Spread Spectrum Control Register

Bit	Name	PWD	Description
Bit 7	Reserved	X	Reserved
Bit 6	Reserved	X	Reserved
Bit 5	Reserved	X	Reserved
Bit 4	SS 12	X	Spread Spectrum Bit 12
Bit 3	SS 11	X	Spread Spectrum Bit 11
Bit 2	SS 10	X	Spread Spectrum Bit 10
Bit 1	SS 9	X	Spread Spectrum Bit 9
Bit 0	SS 8	X	Spread Spectrum Bit 8

Byte 15: Output Divider Control Register

Bit	Name	PWD	Description
Bit 7	CPU Div 3	X	CPU2 clock divider ratio can be configured via these 4 bits individually. For divider selection table refer to Table 1. Default at power up is latched FS divider.
Bit 6	CPU Div 2	X	
Bit 5	CPU Div 1	X	
Bit 4	CPU Div 0	X	
Bit 3	CPU Div 3	X	CPU [1:0] clock divider ratio can be configured via these 4 bits individually. For divider selection table refer to Table 1. Default at power up is latched FS divider.
Bit 2	CPU Div 2	X	
Bit 1	CPU Div 1	X	
Bit 0	CPU Div 0	X	

Byte 16: Output Divider Control Register

Bit	Name	PWD	Description
Bit 7	PCI Div 3	X	3V66 [3:2] clock divider ratio can be configured via these 4 bits individually. For divider selection table refer to Table 1. Default at power up is latched FS divider.
Bit 6	PCI Div 2	X	
Bit 5	PCI Div 1	X	
Bit 4	PCI Div 0	X	
Bit 3	3V66 Div 3	X	3V66 [1:0] clock divider ratio can be configured via these 4 bits individually. For divider selection table refer to Table 1. Default at power up is latched FS divider.
Bit 2	3V66 Div 2	X	
Bit 1	3V66 Div 1	X	
Bit 0	3V66 Div 0	X	

Byte 17: Output Divider Control Register

Bit	Name	PWD	Description
Bit 7	3V66_INV	X	3V66 [3:2] Phase Inversion bit
Bit 6	3V66_INV	X	3V66 Phase Inversion bit
Bit 5	CPU_INV	X	CPUCLK2 Phase Inversion bit
Bit 4	CPU_INV	X	CPUCLK [1:0] Phase Inversion bit
Bit 3	Reserved	X	3V66 [1:0] clock divider ratio can be configured via these 4 bits individually. For divider selection table refer to Table 1. Default at power up is latched FS divider.
Bit 2	Reserved	X	
Bit 1	Reserved	X	
Bit 0	Reserved	X	

Table 1

Div (3:2)	Div (1:0)			
	00	01	10	11
00	/2	/4	/8	/16
01	/3	/6	/12	/24
10	/5	/10	/20	/40
11	/7	/14	/28	/56

Table 2

Div (3:2)	Div (1:0)			
	00	01	10	11
00	/4	/8	/16	/32
01	/3	/6	/12	/24
10	/5	/10	/20	/40
11	/7	/14	/28	/56

Byte 18: Group Skew Control Register

Bit	Name	PWD	Description
Bit 7	CPU_Skew 1	0	These 2 bits delay the CPUCLKC/T2 with respect to CPUCLKC/T (1:0) 00 = 0ps 01 = 250ps 10 = 500ps 11 = 750ps
Bit 6	CPU_Skew 0	1	
Bit 5	Reserved	0	Reserved
Bit 4	Reserved	0	Reserved
Bit 3	CPU_Skew 1	0	These 2 bits delay the CPUCLKC/T (1:0) clock with respect to CPUCLKC/T2 00 = 0ps 01 = 250ps 10 = 500ps 11 = 750ps
Bit 2	CPU_Skew 0	1	
Bit 1	Reserved	0	Reserved
Bit 0	Reserved	0	Reserved

Byte 19: Group Skew Control Register

Bit	Name	PWD	Programming Sequence					
Bit 7	These 4bits control CPU-3V66(3:1)	1	0	0	0	0ps	Reserved	
Bit 6		1	0	1	0	0	150ps	Reserved
Bit 5		1	1	0	0	0	300ps	Reserved
Bit 4		1	1	1	0	0	450ps	Reserved
Bit 3	These 4 bits control CPU-3V66_0	1	1	1	0	1	600ps	Reserved
Bit 2		1	1	1	1	0	750ps	Reserved
Bit 1		1	1	1	1	1	900ps	Reserved
Bit 0		1	Reserved				Reserved	

Byte 20: Group Skew Control Register

Bit	Name	PWD	Programming Sequence					
Bit 7	These 4bits control CPU-PCI(6:0)	1	0	0	0	0	0ps	Reserved
Bit 6		1	0	1	0	0	150ps	Reserved
Bit 5		1	1	0	0	0	300ps	Reserved
Bit 4		1	1	1	0	0	450ps	Reserved
Bit 3	These 4 bits control CPU-PCIF(1:0)	1	1	1	0	1	600ps	Reserved
Bit 2		1	1	1	1	0	750ps	Reserved
Bit 1		1	1	1	1	1	900ps	Reserved
Bit 0		1	Reserved				Reserved	

Byte 21: Slew Rate Control Register

Bit	Name	PWD	Description
Bit 7	PCIF Slew 1	1	PCIF2(1:0) clock slew rate control bits. 01 = strong; 11 = normal; 10 = weak
Bit 6	PCIF Slew 0	0	PCIF1(1:0) clock slew rate control bits. 01 = strong; 11 = normal; 10 = weak
Bit 5	PCIF Slew 1	1	PCIF(1:0) clock slew rate control bits. 01 = strong; 11 = normal; 10 = weak
Bit 4	PCIF Slew 0	0	
Bit 3	3V66 (3:2)_Slew 1	1	3V66 (3:2) clock slew rate control bits. 01 = strong; 11 = normal; 10 = weak
Bit 2	3V66 (3:2)_Slew 0	0	
Bit 1	3V66 (1:0)_Slew 1	1	3V66 (1:0) clock slew rate control bits. 01 = strong; 11 = normal; 10 = weak
Bit 0	3V66 (1:0)_Slew 0	0	

Byte 22: Slew Rate Control Register

Bit	Name	PWD	Description
Bit 7	REF Slew 1	1	REF clock slew rate control bits. 01 = strong; 11 = normal; 10 = weak
Bit 6	REF Slew 0	0	
Bit 5	PCI (6:4) Slew 1	1	PCI (6:4) clock slew rate control bits. 01 = strong; 11 = normal; 10 = weak
Bit 4	PCI (6:4) Slew 0	0	
Bit 3	PCI (3:1) Slew 1	1	PCI (3:1) clock slew rate control bits. 01 = strong; 11 = normal; 10 = weak
Bit 2	PCI (3:1) Slew 0	0	
Bit 1	PCI0 Slew 1	1	PCI0 clock slew rate control bits. 01 = strong; 11 = normal; 10 = weak
Bit 0	PCI0 Slew 0	0	

Byte 23: Slew Rate Control Register

Bit	Name	PWD	Description
Bit 7	Reserved	X	Reserved
Bit 6	Reserved	X	
Bit 5	VCH Slew 1	1	VCH clock slew rate control bits. 01 = strong; 11 = normal; 10 = weak
Bit 4	VCH Slew 0	0	
Bit 3	48USB Slew 1	1	48USB clock slew rate control bits. 01 = strong; 11 = normal; 10 = weak
Bit 2	48USB Slew 0	0	
Bit 1	48DOT Slew 1	1	48DOT clock slew rate control bits. 01 = strong; 11 = normal; 10 = weak
Bit 0	48DOT Slew 0	0	

Absolute Maximum Ratings

Supply Voltage	5.5 V
Logic Inputs	GND -0.5 V to $V_{DD} + 0.5 V$
Ambient Operating Temperature	0°C to +70°C
Case Temperature	115°C
Storage Temperature	-65°C to +150°C

Stresses above those listed under *Absolute Maximum Ratings* may cause permanent damage to the device. These ratings are stress specifications only and functional operation of the device at these or any other conditions above those listed in the operational sections of the specifications is not implied. Exposure to absolute maximum rating conditions for extended periods may affect product reliability.

Electrical Characteristics - Input/Supply/Common Output Parameters

$T_A = 0 - 70^\circ\text{C}$; Supply Voltage $V_{DD} = 3.3 V \pm 5\%$

PARAMETER	SYMBOL	CONDITIONS	MIN	TYP	MAX	UNITS
Input High Voltage	V_{IH}		2		$V_{DD} + 0.3$	V
Input Low Voltage	V_{IL}		$V_{SS} - 0.3$		0.8	V
Input High Current	I_{IH}	$V_{IN} = V_{DD}$	-5		5	mA
Input Low Current	I_{IL1}	$V_{IN} = 0 V$; Inputs with no pull-up resistors	-5			mA
Input Low Current	I_{IL2}	$V_{IN} = 0 V$; Inputs with pull-up resistors	-200			mA
Operating Supply Current	$I_{DD3.3OP}$	$C_L = 0 pF$; Select @ 66M			100	mA
		$C_L = \text{Full load}$			360	mA
Power Down Supply Current	$I_{DD3.3PD}$	IREF=2.32			25	mA
		IREF= 5mA			45	mA
Input frequency	F_i	$V_{DD} = 3.3 V$;		14.318		MHz
Pin Inductance	L_{pin}				7	nH
Input Capacitance ¹	C_{IN}	Logic Inputs			5	pF
	C_{out}	Out put pin capacitance			6	pF
	C_{INX}	X1 & X2 pins	27	36	45	pF
Transition Time ¹	T_{trans}	To 1st crossing of target Freq.			3	mS
Settling Time ¹	T_s	From 1st crossing to 1% target Freq.			3	mS
Clk Stabilization ¹	T_{STAB}	From $V_{DD} = 3.3 V$ to 1% target Freq.			3	mS
Delay	t_{PZH}, t_{PZH}	output enable delay (all outputs)	1		10	nS
	t_{PLZ}, t_{PZH}	output disable delay (all outputs)	1		10	nS

¹Guaranteed by design, not 100% tested in production.

Electrical Characteristics - CPUCLK

$T_A = 0 - 70^\circ\text{C}$; $V_{DD} = 3.3\text{ V} \pm 5\%$; (unless otherwise stated)

PARAMETER	SYMBOL	CONDITIONS	MIN	TYP	MAX	UNITS
Current Source Output Impedance	Z_O	$V_O = V_X$	3000			Ω
Output High Voltage	V_{OH}	$V_R = 475\text{W} \pm 1\%$; $I_{REF} = 2.32\text{mA}$; $I_{OH} = 6 \cdot I_{REF}$		0.71	1.2	V
Output High Current	I_{OH}			-13.92		mA
Rise Time ¹	t_r	$V_{OL} = 20\%$, $V_{OH} = 80\%$	175		700	ps
Differential Crossover Voltage ¹	V_X	Note 3	45	50	55	%
Duty Cycle ¹	d_t	$V_T = 50\%$	45	49.4	55	%
Skew ¹ , CPU to CPU	t_{sk}	$V_T = 50\%$		40	100	ps
Jitter, Cycle-to-cycle ¹	$t_{cyc-cyc}$	$V_T = V_X$		90	150	ps

Notes:

1 - Guaranteed by design, not 100% tested in production.

Electrical Characteristics - PCICLK

$T_A = 0 - 70^\circ\text{C}$; $V_{DD} = 3.3\text{ V} \pm 5\%$; $C_L = 10\text{-}30\text{ pF}$ (unless otherwise stated)

PARAMETER	SYMBOL	CONDITIONS	MIN	TYP	MAX	UNITS
Output Frequency	F_0^1			33.33		MHz
Output Impedance	R_{DSN1}^1	$V_O = V_{DD} \cdot (0.5)$	12		55	Ω
Output High Voltage	V_{OH1}	$I_{OH} = -1\text{ mA}$	2.4			V
Output Low Voltage	V_{OL1}	$I_{OL} = 1\text{ mA}$			0.55	V
Output High Current	I_{OH1}	$V_{OH@MIN} = 1.0\text{ V}$, $V_{OH@MAX} = 3.135\text{ V}$	-33		-33	mA
Output Low Current	I_{OL1}	$V_{OL@MIN} = 1.95\text{ V}$, $V_{OL@MAX} = 0.4$	30		38	mA
Rise Time	t_{r1}^1	$V_{OL} = 0.4\text{ V}$, $V_{OH} = 2.4\text{ V}$	0.5	1.52	2	ns
Fall Time	t_{f1}^1	$V_{OH} = 2.4\text{ V}$, $V_{OL} = 0.4\text{ V}$	0.5	1.45	2	ns
Duty Cycle	d_{t1}^1	$V_T = 1.5\text{ V}$	45	51.5	55	%
Skew	t_{sk1}^1	$V_T = 1.5\text{ V}$		155	500	ps
Jitter	$t_{cyc-cyc}^1$	$V_T = 1.5\text{ V}$		123	250	ps

¹Guaranteed by design, not 100% tested in production.

Electrical Characteristics - 3V66

$T_A = 0 - 70^\circ\text{C}$; $V_{DD} = 3.3\text{ V} \pm 5\%$; $C_L = 10\text{-}30\text{ pF}$ (unless otherwise stated)

PARAMETER	SYMBOL	CONDITIONS	MIN	TYP	MAX	UNITS
Output Frequency	F_{O1}			66.66		MHz
Output Impedance	R_{DSP1}^1	$V_O = V_{DD}^*(0.5)$	12		55	Ω
Output High Voltage	V_{OH1}	$I_{OH} = -1\text{ mA}$	2.4			V
Output Low Voltage	V_{OL1}	$I_{OL} = 1\text{ mA}$			0.4	V
Output High Current	I_{OH1}	$VOH@\text{ MIN} = 1.0\text{ V}$, $VOH@\text{ MAX} = 3.135\text{ V}$	-33		-33	mA
Output Low Current	I_{OL1}	$VOL@\text{ MIN} = 1.95\text{ V}$, $VOL@\text{ MAX} = 0.4$	30		38	mA
Rise Time	t_{r1}^1	$V_{OL} = 0.4\text{ V}$, $V_{OH} = 2.4\text{ V}$	0.5	3	2	ns
Fall Time	t_{f1}^1	$V_{OH} = 2.4\text{ V}$, $V_{OL} = 0.4\text{ V}$	0.5	1.3	2	ns
Duty Cycle	d_{t1}^1	$V_T = 1.5\text{ V}$	45	52	55	%
Skew	t_{sk1}^1	$V_T = 1.5\text{ V}$		155	500	ps
Jitter	$t_{j\text{cyc-cyc}}^1$	$V_T = 1.5\text{ V}$		150	250	ps

¹Guaranteed by design, not 100% tested in production.

Electrical Characteristics - VCH, 48MHz DOT, 48MHz, USB

$T_A = 0 - 70^\circ\text{C}$; $V_{DD} = 3.3\text{ V} \pm 5\%$; $C_L = 10\text{-}30\text{ pF}$ (unless otherwise stated)

PARAMETER	SYMBOL	CONDITIONS	MIN	TYP	MAX	UNITS
Output Frequency	F_O^1	$V_O = V_{DD}^*(0.5)$		48		MHz
Output Impedance	R_{DSN1}^1	$V_O = V_{DD}^*(0.5)$	12		55	Ω
Output High Voltage	V_{OH1}	$I_{OH} = -1\text{ mA}$	2.4			V
Output Low Voltage	V_{OL1}	$I_{OL} = 1\text{ mA}$			0.55	V
Output High Current	I_{OH1}	$VOH@\text{ MIN} = 1.0\text{ V}$, $VOH@\text{ MAX} = 3.135\text{ V}$	-29		-23	mA
Output Low Current	I_{OL1}	$VOL@\text{ MIN} = 1.95\text{ V}$, $VOL@\text{ MAX} = 0.4$	29		27	mA
48DOT Rise Time	t_{r1}^1	$V_{OL} = 0.4\text{ V}$, $V_{OH} = 2.4\text{ V}$	0.5	0.6	1	ns
48DOT Fall Time	t_{f1}^1	$V_{OH} = 2.4\text{ V}$, $V_{OL} = 0.4\text{ V}$	0.5	0.7	1	ns
VCH 48 USB Rise Time	t_r^1	$V_{OL} = 0.4\text{ V}$, $V_{OH} = 2.4\text{ V}$	1	1.1	2	ns
VCH 48 USB Fall Time	t_f^1	$V_{OH} = 2.4\text{ V}$, $V_{OL} = 0.4\text{ V}$	1	1.2	2	ns
48 DOT to 48 USB Skew	t_{skew}^1	$V_T = 1.5\text{ V}$			1	ns
Duty Cycle	d_{t1}^1	$V_T = 1.5\text{ V}$	45	50.1	55	%
Jitter	$t_{j\text{cyc-cyc}}^1$	$V_T = 1.5\text{ V}$		130	350	ps

¹Guaranteed by design, not 100% tested in production.

Electrical Characteristics - REF

$T_A = 0 - 70^\circ\text{C}$; $V_{DD} = 3.3\text{ V} \pm 5\%$; $C_L = 10\text{-}20\text{ pF}$ (unless otherwise stated)

PARAMETER	SYMBOL	CONDITIONS	MIN	TYP	MAX	UNITS
Output Frequency	F_{O1}					MHz
Output Impedance	R_{DSP1}^1	$V_O = V_{DD} \cdot (0.5)$	20		60	Ω
Output High Voltage	V_{OH1}	$I_{OH} = -1\text{ mA}$	2.4			V
Output Low Voltage	V_{OL1}	$I_{OL} = 1\text{ mA}$			0.4	V
Output High Current	I_{OH1}	$V_{OH@\text{MIN}} = 1.0\text{ V}$, $V_{OH@\text{MAX}} = 3.135\text{ V}$	-29		-23	mA
Output Low Current	I_{OL1}	$V_{OL@\text{MIN}} = 1.95\text{ V}$, $V_{OL@\text{MAX}} = 0.4$	29		27	mA
Rise Time	t_{r1}^1	$V_{OL} = 0.4\text{ V}$, $V_{OH} = 2.4\text{ V}$	1		4	ns
Fall Time	t_{f1}^1	$V_{OH} = 2.4\text{ V}$, $V_{OL} = 0.4\text{ V}$	1		4	ns
Duty Cycle	d_{t1}^1	$V_T = 1.5\text{ V}$	45	53	55	%
Jitter	$t_{j\text{cyc-cyc}}$	$V_T = 1.5\text{ V}$			500	ps

¹Guaranteed by design, not 100% tested in production.

Shared Pin Operation - Input/Output Pins

The I/O pins designated by (input/output) serve as dual signal functions to the device. During initial power-up, they act as input pins. The logic level (voltage) that is present on these pins at this time is read and stored into a 5-bit internal data latch. At the end of Power-On reset, (see AC characteristics for timing values), the device changes the mode of operations for these pins to an output function. In this mode the pins produce the specified buffered clocks to external loads.

To program (load) the internal configuration register for these pins, a resistor is connected to either the VDD (logic 1) power supply or the GND (logic 0) voltage potential. A 10 Kiloohm (10K) resistor is used to provide both the solid CMOS programming voltage needed during the power-up programming period and to provide an insignificant load on the output clock during the subsequent operating period.

Figure 1 shows a means of implementing this function when a switch or 2 pin header is used. With no jumper is installed the pin will be pulled high. With the jumper in place the pin will be pulled low. If programmability is not necessary, than only a single resistor is necessary. The programming resistors should be located close to the series termination resistor to minimize the current loop area. It is more important to locate the series termination resistor close to the driver than the programming resistor.

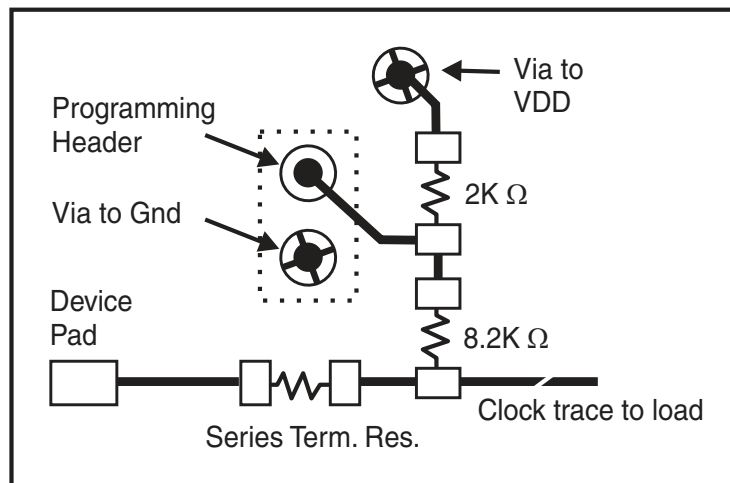
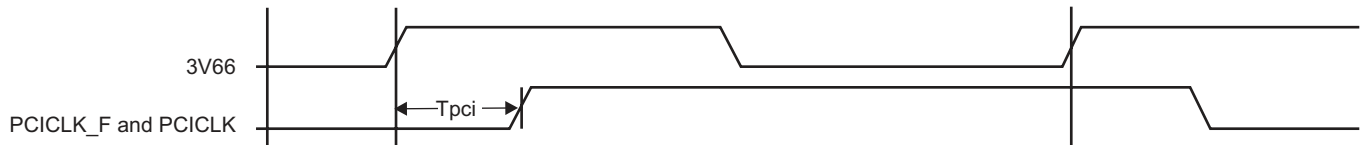

Fig. 1

Un-Buffered Mode 3V66 & PCI Phase Relationship

All 3V66 clocks are to be in pphase with each other. In the case where 3V66_1 is configured as 48MHz VCH clock, there is no defined phase relationship between 3V66_1/VCH and other 3V66 clocks. The PCI group should lag 3V66 by the standard skew described below as Tpci.



Group Skews at Common Transition Edges: (Un-Buffered Mode)

GROUP	SYMBOL	CONDITIONS	MIN	TYP	MAX	UNITS
3V66	3V66	3V66 pin to pin skew	0	155	500	ps
PCI	PCI	PCI_F and PCI pin to pin skew	0	302	500	ps
3V66 to PCI	S _{3V66-PCI}	3V66 leads 33MHz PCI	1.5	1.7	3.5	ns

¹Guaranteed by design, not 100% tested in production.

PD# Functionality

CPU_STOP#	CPUT	CPUC	3V66	66MHz_OUT	PCICLK_F PCICLK	PCICLK	USB/DOT 48MHz
1	Normal	Normal	66MHz	66MHz_IN	66MHz_IN	66MHz_IN	48MHz
0	iref * Mult	Float	Low	Low	Low	Low	Low

PCI_STOP# - Assertion (transition from logic "1" to logic "0")

The impact of asserting the PCI_STOP# signal will be the following. All PCI[6:0] and stoppable PCI_F[2,0] clocks will latch low in their next high to low transition. The PCI_STOP# setup time t_{su} is 10 ns, for transitions to be recognized by the next rising edge.

Assertion of PCI_STOP# Waveforms

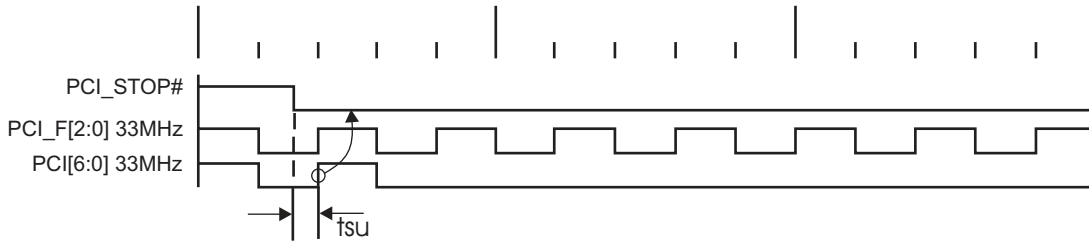

CPU_STOP# - Assertion (transition from logic "1" to logic "0")

The impact of asserting the CPU_STOP# pin is all CPU outputs that are set in the I²C configuration to be stoppable via assertion of CPU_STOP# are to be stopped after their next transition following the two CPU clock edge sampling as shown. The final state of the stopped CPU signals is CPUT=High and CPUC=Low. There is to be no change to the output drive current values. The CPUT will be driven high with a current value equal to (MULTSELO) X (I REF), the CPUC signal will not be driven.

Assertion of CPU_STOP# Waveforms

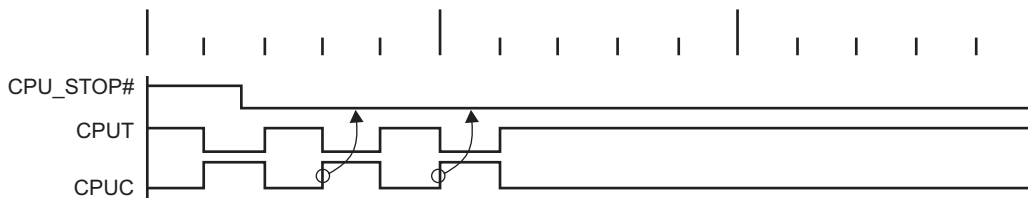

CPU_STOP# Functionality

CPU_STOP#	CPUT	CPUC
1	Normal	Normal
0	$i_{ref} * Mult$	Float

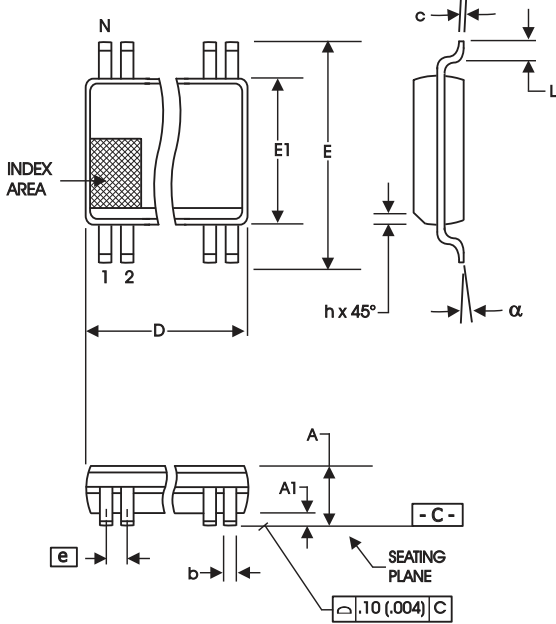

300 mil SSOP Package

SYMBOL	In Millimeters		In Inches	
	COMMON DIMENSIONS	COMMON DIMENSIONS	COMMON DIMENSIONS	COMMON DIMENSIONS
A	2.41	2.80	.095	.110
A1	0.20	0.40	.008	.016
b	0.20	0.34	.008	.0135
c	0.13	0.25	.005	.010
D	SEE VARIATIONS		SEE VARIATIONS	
E	10.03	10.68	.395	.420
E1	7.40	7.60	.291	.299
e	0.635 BASIC		0.025 BASIC	
h	0.38	0.64	.015	.025
L	0.50	1.02	.020	.040
N	SEE VARIATIONS		SEE VARIATIONS	
alpha	0°	8°	0°	8°

VARIATIONS

N	D mm.		D (inch)	
	MIN	MAX	MIN	MAX
56	18.31	18.55	.720	.730

Reference Doc.: JEDEC Publication 95, MO-118

10-0034

Ordering Information

ICS950211yFLF-T

Example:

ICS XXXX y F LF-T

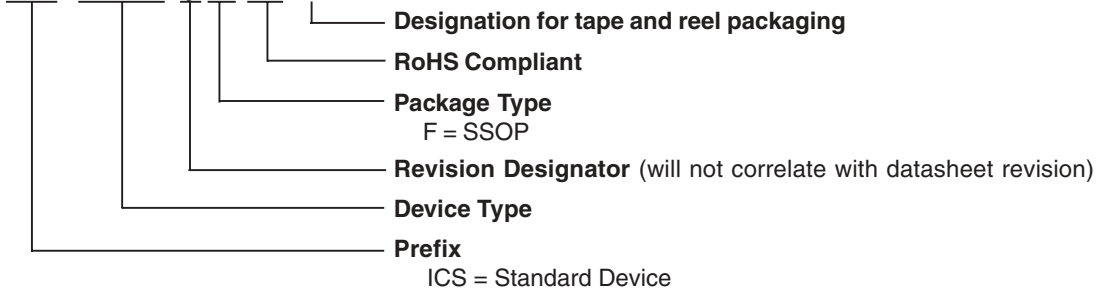

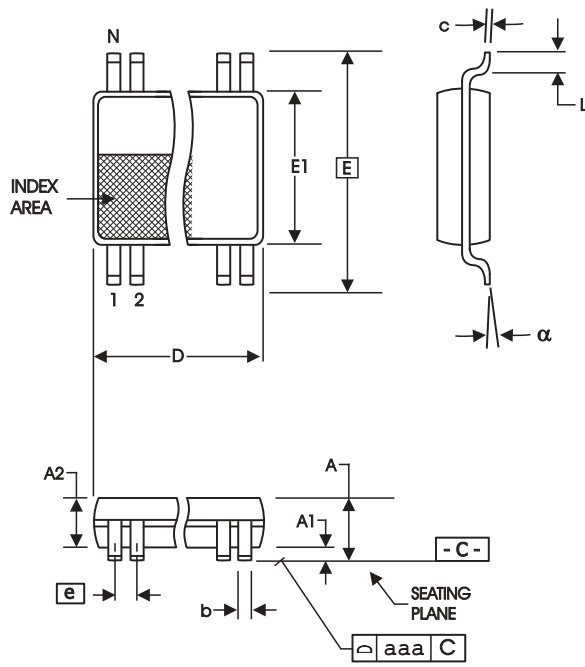

240 mil TSSOP Package

56-Lead 6.10 mm. Body, 0.50 mm. Pitch TSSOP
(240 mil) (20 mil)

SYMBOL	In Millimeters COMMON DIMENSIONS		In Inches COMMON DIMENSIONS	
	MIN	MAX	MIN	MAX
A	--	1.20	--	.047
A1	0.05	0.15	.002	.006
A2	0.80	1.05	.032	.041
b	0.17	0.27	.007	.011
c	0.09	0.20	.0035	.008
D	SEE VARIATIONS		SEE VARIATIONS	
E	8.10 BASIC		0.319 BASIC	
E1	6.00	6.20	.236	.244
e	0.50 BASIC		0.020 BASIC	
L	0.45	0.75	.018	.030
N	SEE VARIATIONS		SEE VARIATIONS	
a	0°	8°	0°	8°
aaa	--	0.10	--	.004

VARIATIONS

N	D mm.		D (inch)	
	MIN	MAX	MIN	MAX
56	13.90	14.10	.547	.555

Reference Doc.: JEDEC Publication 95, MO-153

10-0039

Ordering Information

ICS950211yGLF-T

Example:

ICS XXXX y G LF-T

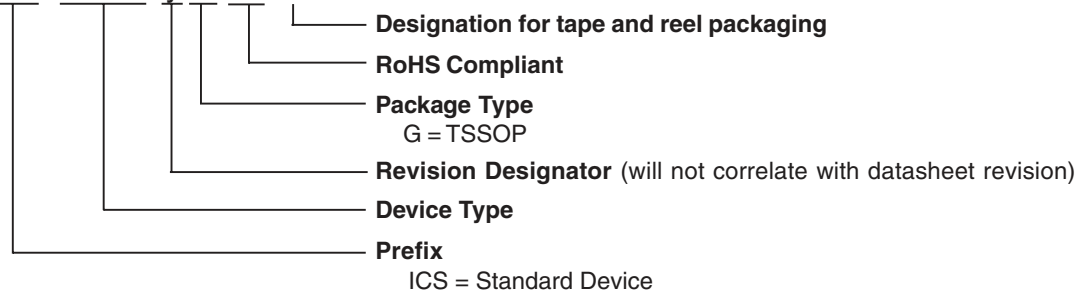

Revision History

Rev.	Issue Date	Description	Page #
E	5/17/2005	1. Updated Description on Byte 13. 2. Updated LF Ordering Information from "Lead Free" to "RoHS Compliant".	9,19-20

IMPORTANT NOTICE AND DISCLAIMER

RENESAS ELECTRONICS CORPORATION AND ITS SUBSIDIARIES (“RENESAS”) PROVIDES TECHNICAL SPECIFICATIONS AND RELIABILITY DATA (INCLUDING DATASHEETS), DESIGN RESOURCES (INCLUDING REFERENCE DESIGNS), APPLICATION OR OTHER DESIGN ADVICE, WEB TOOLS, SAFETY INFORMATION, AND OTHER RESOURCES “AS IS” AND WITH ALL FAULTS, AND DISCLAIMS ALL WARRANTIES, EXPRESS OR IMPLIED, INCLUDING, WITHOUT LIMITATION, ANY IMPLIED WARRANTIES OF MERCHANTABILITY, FITNESS FOR A PARTICULAR PURPOSE, OR NON-INFRINGEMENT OF THIRD PARTY INTELLECTUAL PROPERTY RIGHTS.

These resources are intended for developers skilled in the art designing with Renesas products. You are solely responsible for (1) selecting the appropriate products for your application, (2) designing, validating, and testing your application, and (3) ensuring your application meets applicable standards, and any other safety, security, or other requirements. These resources are subject to change without notice. Renesas grants you permission to use these resources only for development of an application that uses Renesas products. Other reproduction or use of these resources is strictly prohibited. No license is granted to any other Renesas intellectual property or to any third party intellectual property. Renesas disclaims responsibility for, and you will fully indemnify Renesas and its representatives against, any claims, damages, costs, losses, or liabilities arising out of your use of these resources. Renesas' products are provided only subject to Renesas' Terms and Conditions of Sale or other applicable terms agreed to in writing. No use of any Renesas resources expands or otherwise alters any applicable warranties or warranty disclaimers for these products.

(Disclaimer Rev.1.0 Mar 2020)

Corporate Headquarters

TOYOSU FORESIA, 3-2-24 Toyosu,
Koto-ku, Tokyo 135-0061, Japan
www.renesas.com

Contact Information

For further information on a product, technology, the most up-to-date version of a document, or your nearest sales office, please visit:
www.renesas.com/contact/

Trademarks

Renesas and the Renesas logo are trademarks of Renesas Electronics Corporation. All trademarks and registered trademarks are the property of their respective owners.