

LOC		DIST		REVISIONS			
AG	00	REV	DATE	BY	APP'D	DATE	BY
U		REVISED PER ECO-06-007841	19JUL06	JDP	MB		

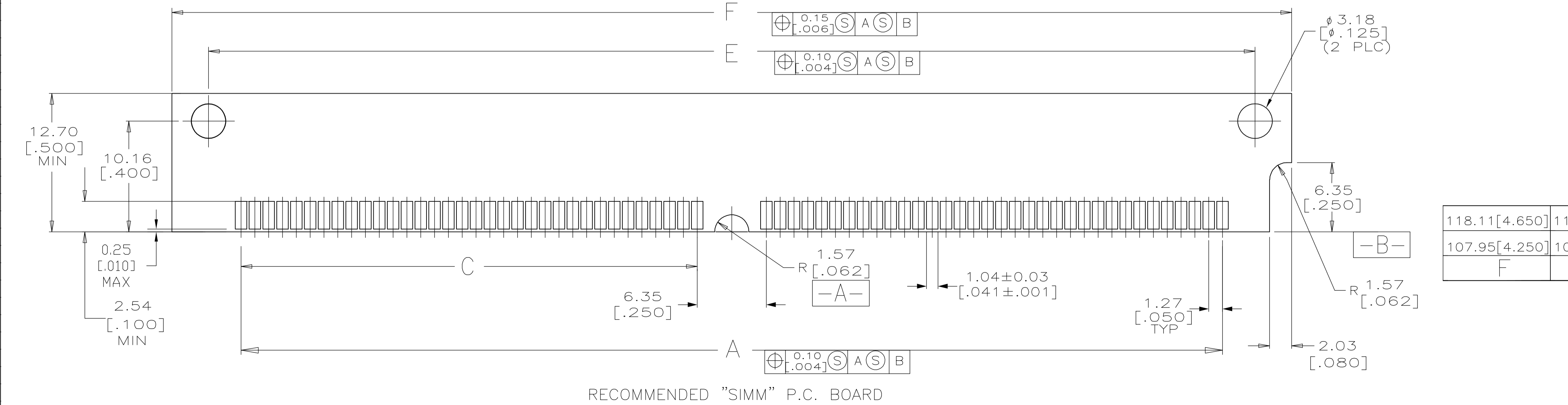

- △ HOUSING—MATERIAL : LIQUID—CRYSTAL—POLYMER.
- △ CONTACT—MATERIAL : PHOS. BRONZE.
- △ LATCH—MATERIAL : STAINLESS STEEL.
- △ CONTACT—PLATE 0.00127 [.000050] MIN NICKEL ALL OVER.
- △ CONTACT—PLATE 0.00076 [.000030] MIN. GOLD AT CONTACT PTS.
- △ CONTACT SOLDER TAILS—PLATE 0.00508 [.000200] MIN TIN/LEAD.
- 7. IN ADDITION TO THOSE RECOMMENDED "SIMM" P.C. BOARD DIMENSIONS AND TOLERANCES SHOWN, ALL JEDEC SPECIFICATIONS APPLY AS SHOWN ON MO-116, ISSUE A.
- 8. RECOMMENDED MATING S.I.M.M. TAB METALLURGY:
 - BASE METAL—COPPER. PLATING TO BE 0.00076 [.000030] MIN GOLD OVER 0.00127 [.000050] MIN NICKEL.
- △ 'S' IDENTIFIER LOCATED APPROXIMATELY AS SHOWN.
- △ 10 DATE CODE INFORMATION (YEAR WEEK), LOCATED APPROXIMATELY AS SHOWN ON OPPOSITE SIDE ONLY.

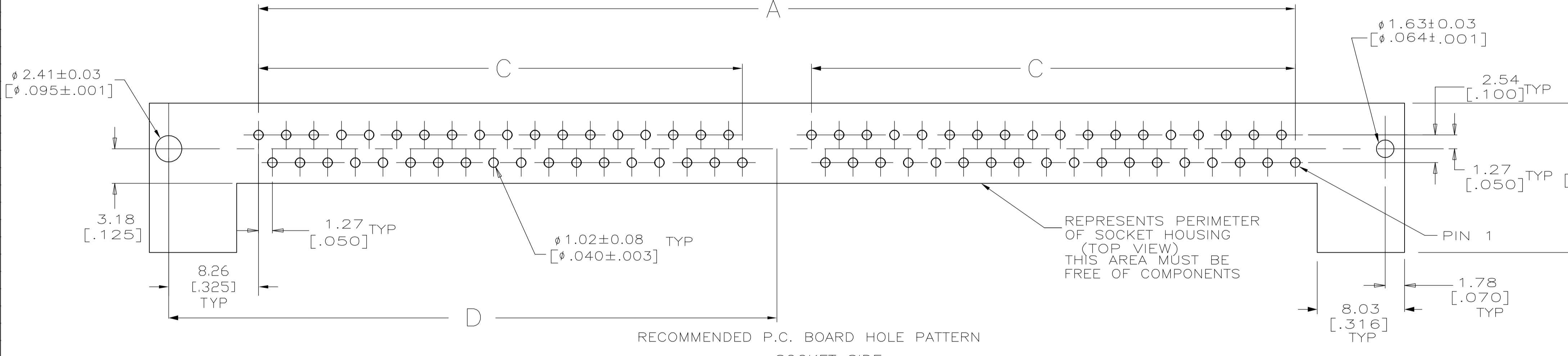
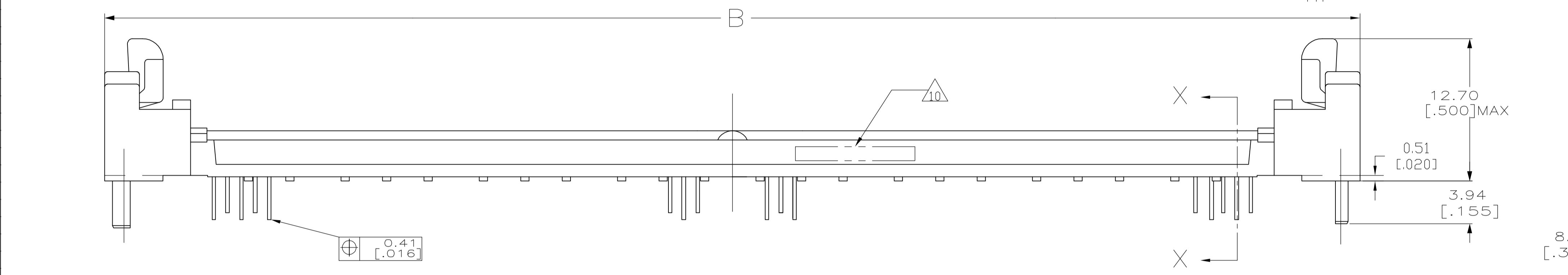
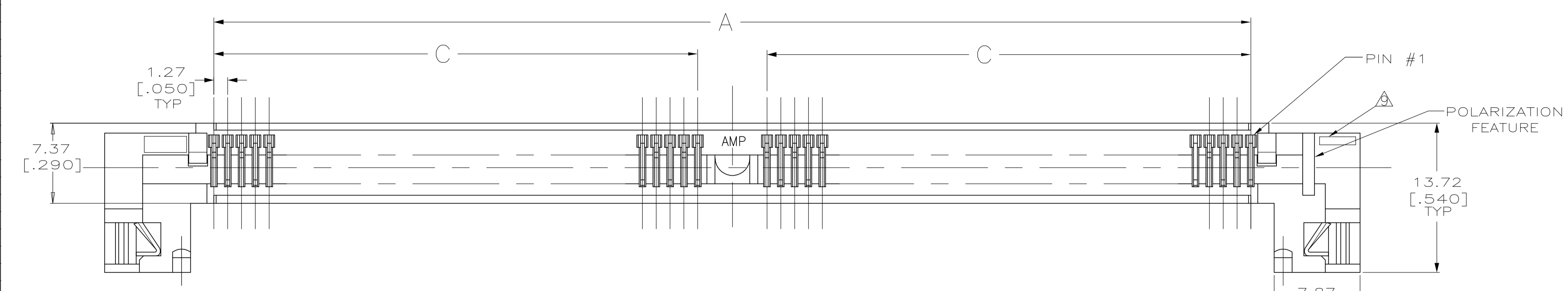
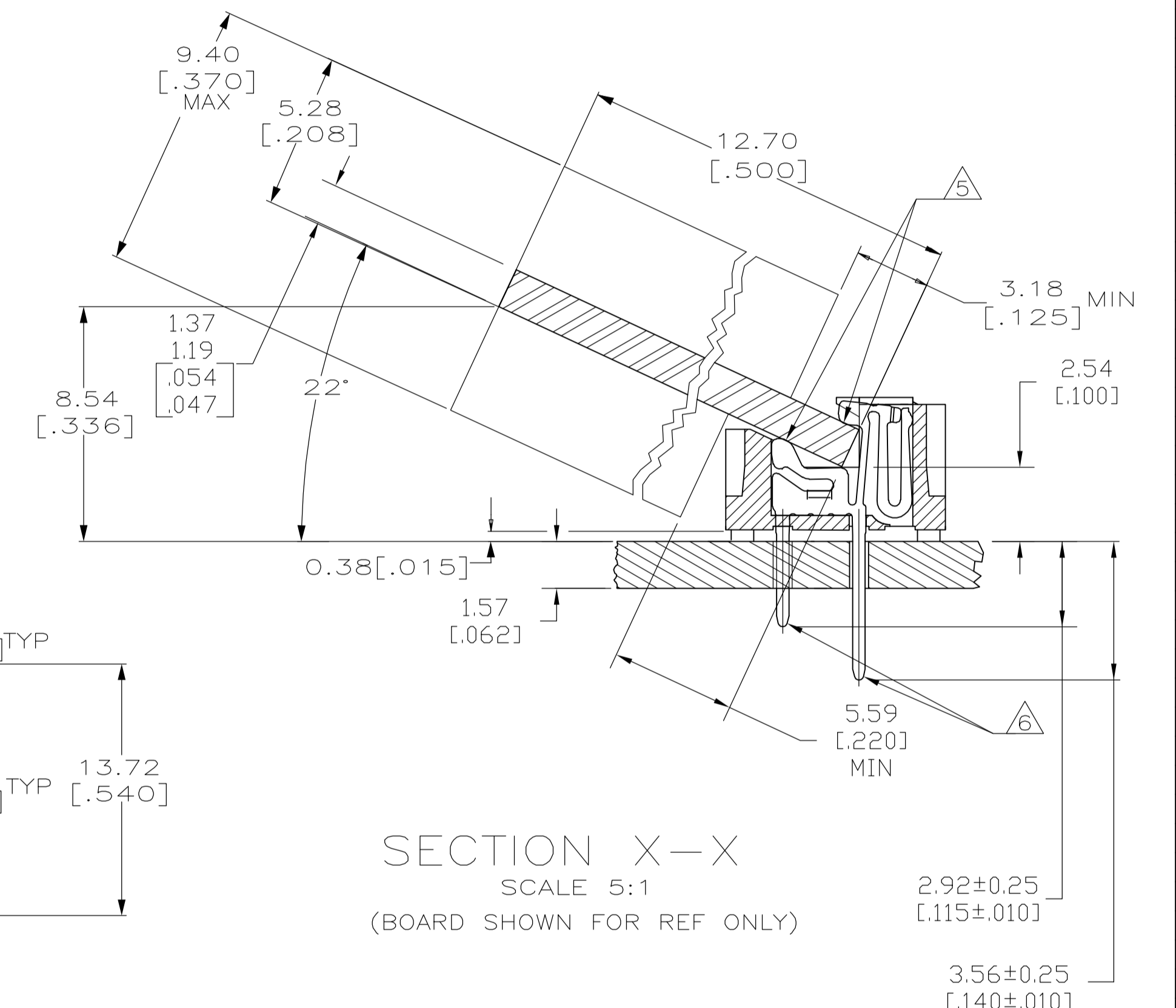

118.11 [4.650]	111.35 [4.384]	60.96 [2.400]	49.53 [1.950]	125.48 [4.940]	105.41 [4.150]	80	822138-4
107.95 [4.250]	101.19 [3.984]	55.88 [2.200]	44.45 [1.750]	115.32 [4.540]	95.25 [3.750]	72	822138-3
F	E	D	C	B	A	NO. OF POS	PART NO

THIS DRAWING IS A CONTROLLED DOCUMENT.		DIN 9137 MCMMASTER 07JAN04	Tyco Electronics Corporation Harrisburg, PA 17105-3608
DIMENSIONS: mm [INCHES]		07JAN04	
TOLERANCES UNLESS OTHERWISE SPECIFIED:		07JAN04	Tyco Electronics Corporation Harrisburg, PA 17105-3608
0 PLC ± -		07JAN04	
1 PLC ± -		07JAN04	CONNECTOR, MICRO-EDGE, .050, LP, GOLD PL. W/METAL LATCH
2 PLC ± -		07JAN04	
3 PLC ± 0.13 [.005]		07JAN04	SIZE: A1
4 PLC ± -		07JAN04	
ANGLES ± -		07JAN04	CAGE CODE: 00779
FINISH: △△△△		07JAN04	
MATERIAL: △△△△		07JAN04	DRAWING NO: 822138
FINISH: △△△△		07JAN04	
CUSTOMER DRAWING		07JAN04	RESTRICTED TO: -
SCALE: 4:1		07JAN04	SHEET: 1 OF 1
REV: U		07JAN04	REV: U