

THIS DRAWING IS UNPUBLISHED. RELEASED FOR PUBLICATION, 19 .
© COPYRIGHT 19 BY AMP INCORPORATED. ALL INTERNATIONAL RIGHTS RESERVED.

LOC	DIST	P	F	REVISIONS			DATE	APPD
AF	50			ZONE	LTR	DESCRIPTION		
					B	RELEASED PER FASR AND 0L10-0061-96	29/AUG/96	PF/GY

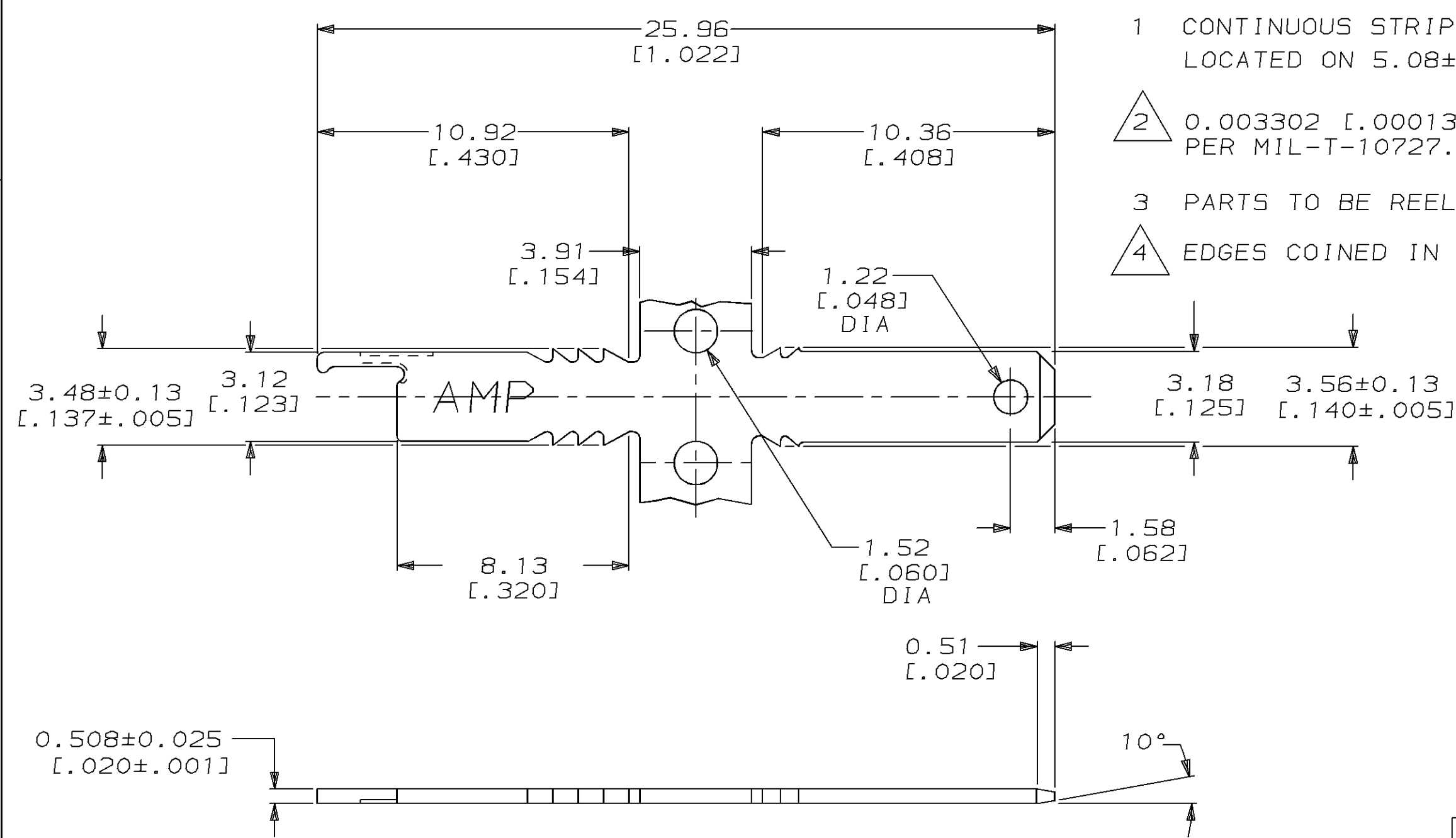

- 1 CONTINUOUS STRIP ON REEL WITH TERMINALS LOCATED ON 5.08±0.08 [.200±.003] CENTERS.
- 2 0.003302 [.000130] MAX PRE-TIN PLATE PER MIL-T-10727.
- 3 PARTS TO BE REELED WITH PAPER.
- 4 EDGES COINED IN THIS AREA TO REMOVE BURRS.

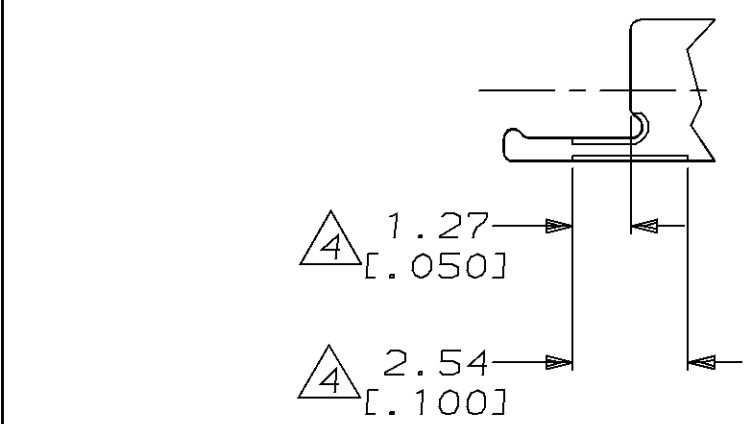

THIS DRAWING IS A CONTROLLED DOCUMENT FOR AMP INCORPORATED. IT IS SUBJECT TO CHANGE AND THE CONTROLLING ENGINEERING ORGANIZATION SHOULD BE CONTACTED FOR THE LATEST REVISION.

DO NOT SCALE PRINT, UNLESS SPECIFIED DIMENSIONS IN mm [INCHES] TOLERANCES ON: 2 PLC DEC ± 0.25 [.010] 3 PLC DEC ± - ANGLES ± -	DR 28/FEB/96 PHILLIP M FORTNEY
	CHK 28/FEB/96 JEFF R RUTH
	APPD 28/FEB/96 GARY YETTER
	APPD 28/FEB/96 MARK BARNABA
MATERIAL 082 BRASS	PRODUCT SPEC -
FINISH SEE TABLE	APPLICATION SPEC -
	WEIGHT -

2		63917-1
FINISH		PART NO
AMP		AMP Incorporated Harrisburg, PA 17105-3608
NAME BOBBIN TAB		
SIZE B	CAGE CODE 00779	DRAWING NO C-63917
SCALE 6:1	SHEET 1 OF 1	