

THIS DRAWING IS UNPUBLISHED. RELEASED FOR PUBLICATION
 © COPYRIGHT - By - ALL RIGHTS RESERVED.

LOC	DIST	REVISIONS			
P	LTR	DESCRIPTION	DATE	DWN	APVD
AF	50	N	REVISED PER ECR-12-013486	06JAN13	KH KR

SUGGESTED MATING TAB

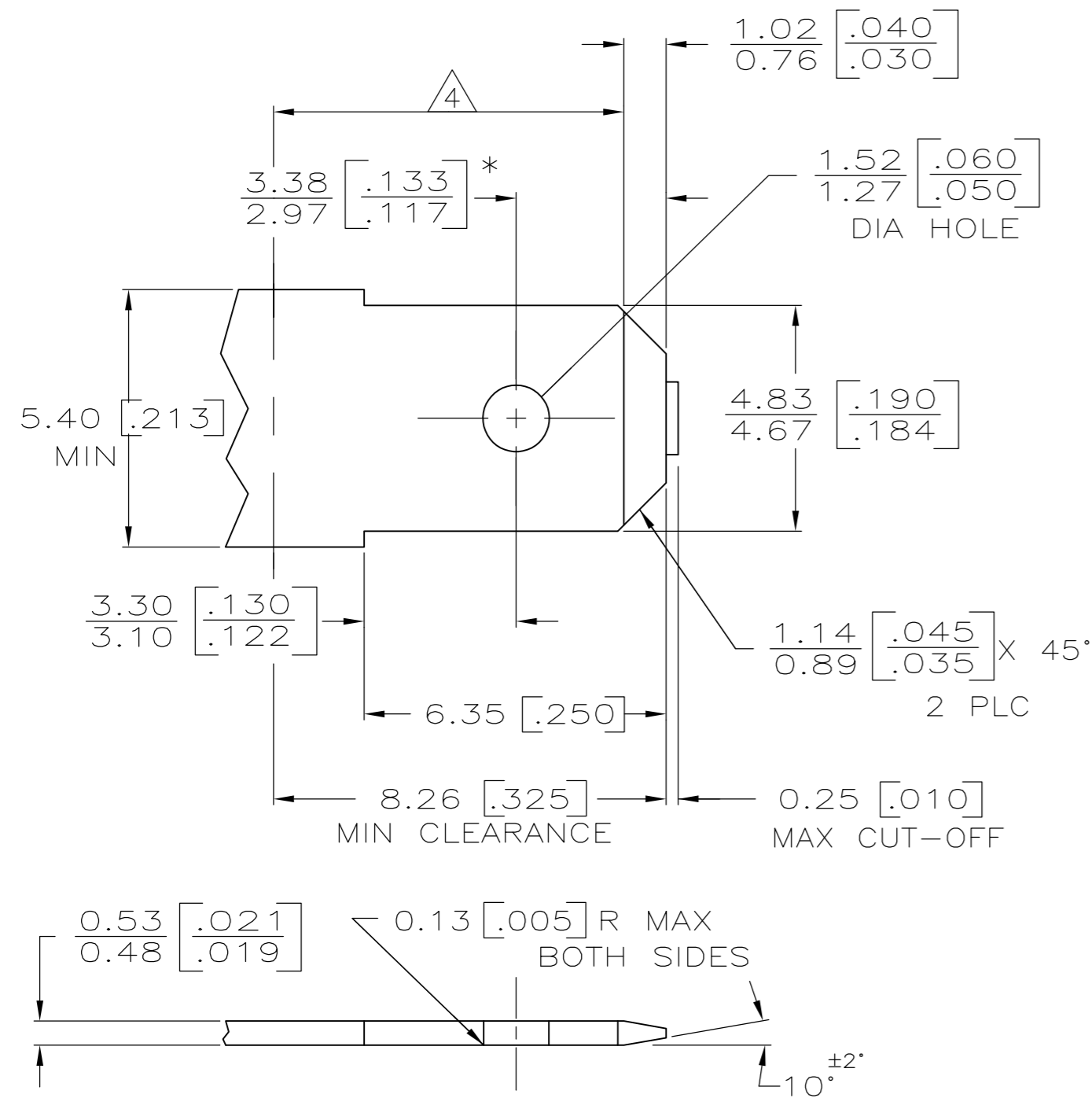

- MATL: #2 HARD BRASS OR NICKEL PLATE STEEL.
 - NO BURRS PERMISSIBLE AT HOLE.
 - TIN PLATING IS REQUIRED ON BRASS WHEN TERMINAL TEMPERATURE IS OVER 225°F
 - MUST BE FLAT WITHIN 0.076 [.003] OVER THIS LENGTH.
 - HOLE MUST BE SYMMETRICAL ABOUT TAB ϕ WITHIN 0.076 [.003].
- * TO BE USED ONLY WHEN SHOULDER IS ELIMINATED.

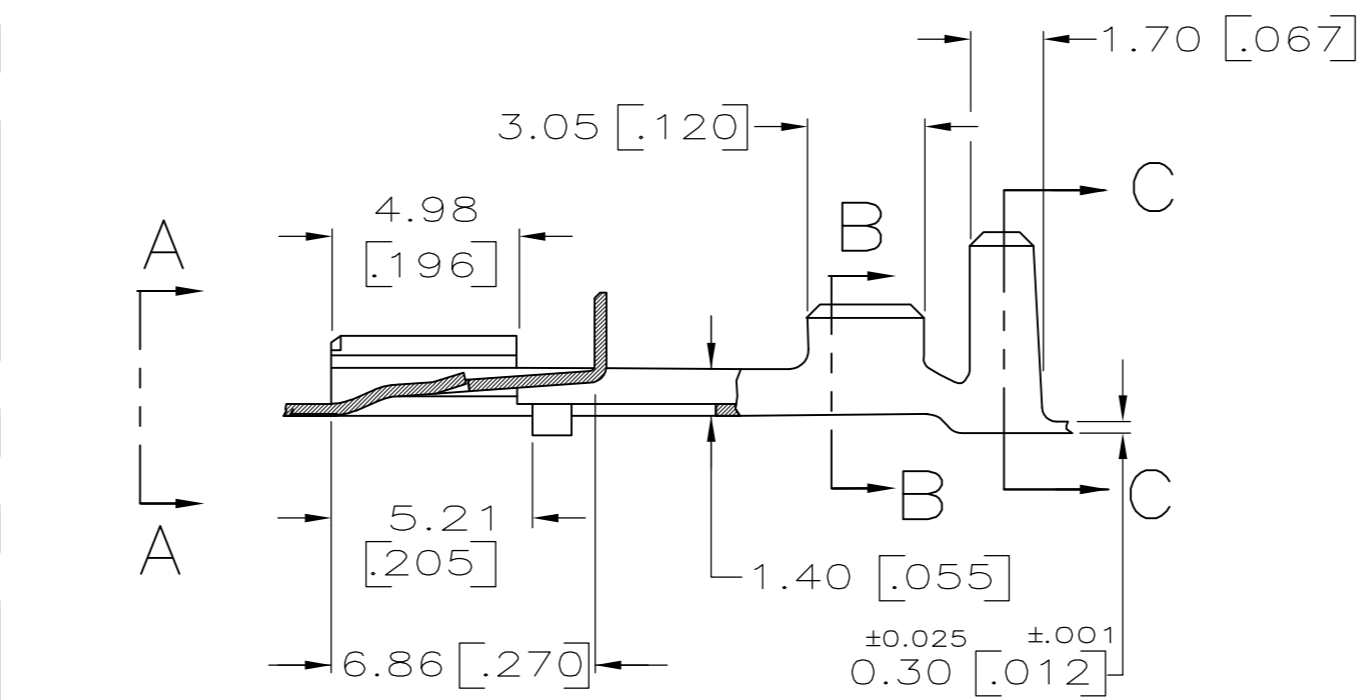
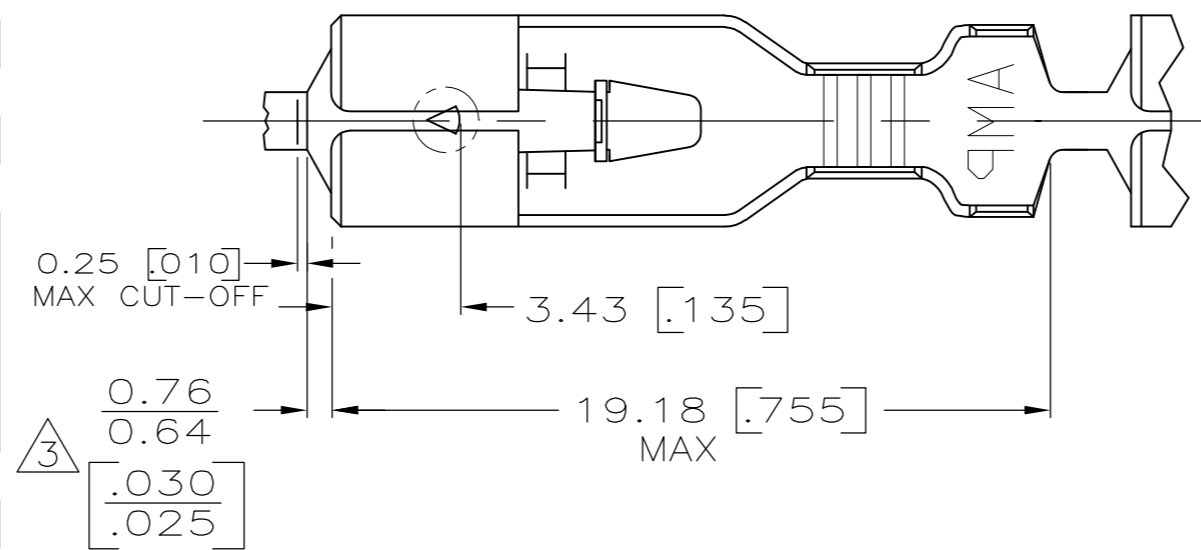

- DIMENSIONS IN BRACKETS ARE IN INCHES.
- CONTINUOUS STRIP ON REELS.
- THE 0.76 [.030] / 0.64 [.025] DIMENSION MUST BE MAINTAINED BY THE APPLICATOR CUT-OFF TO ENSURE THE PROPER LOCKING FUNCTION OF THE RECEPTACLE.
- WIRE SIZES #20-#16, INSULATION RANGE IS 2.29-3.30 [.090-.130] DIA.

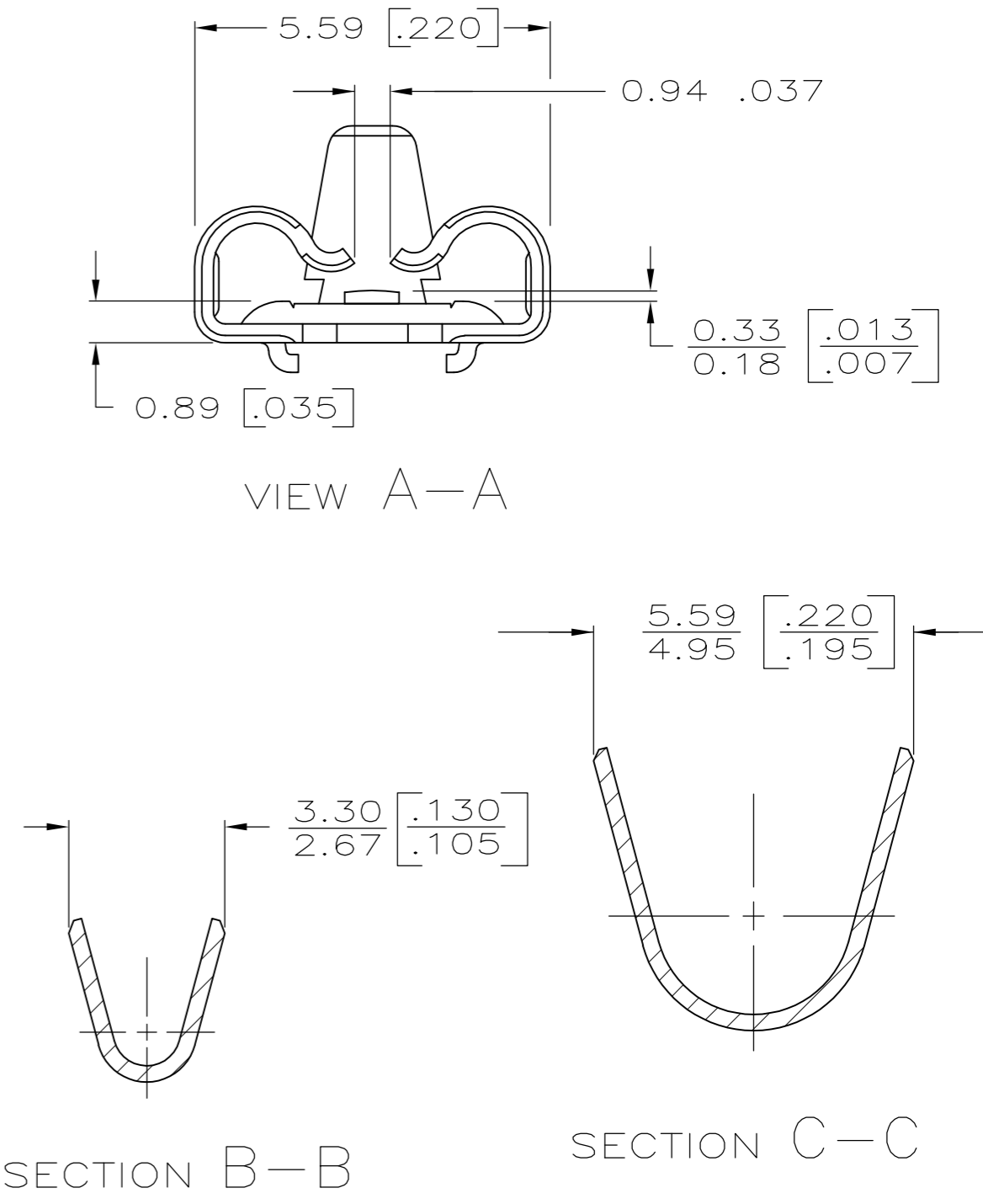

THIS DRAWING IS A CONTROLLED DOCUMENT.		DWN	JR RUTH	2/28/87	 TE Connectivity RECEPTACLE, POSITIVE LOCK, .187 SERIES
DIMENSIONS: mm [INCHES]		CHK	G YETTER	3/9/87	
TOLERANCES UNLESS OTHERWISE SPECIFIED:		APVD	J GILLESPIE	3/9/87	
0 PLC ± - 1 PLC ± - 2 PLC ± - 3 PLC ± 0.25 [.010] 4 PLC ± - ANGLES ± -		PRODUCT SPEC			
MATERIAL	BRASS	FINISH	SEE TABLE	WEIGHT	-
CUSTOMER DRAWING		SCALE	NTS	SHEET	1 OF 1
		SIZE	A2	CAGE CODE	00779
		DRAWING NO	C=63195		RESTRICTED TO
		REV	N		