

PRODUCT NUMBER
SEE SHEET 3

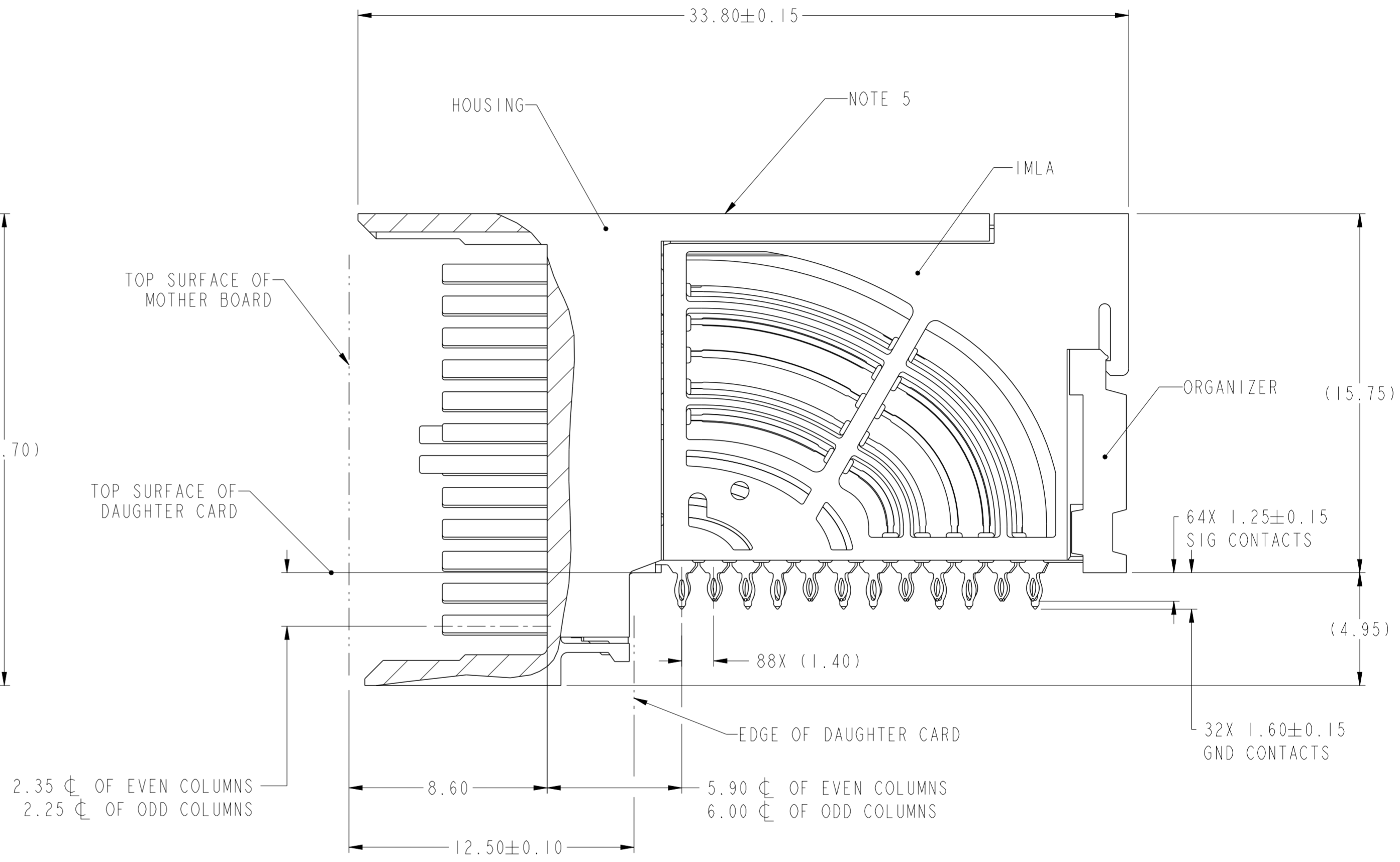
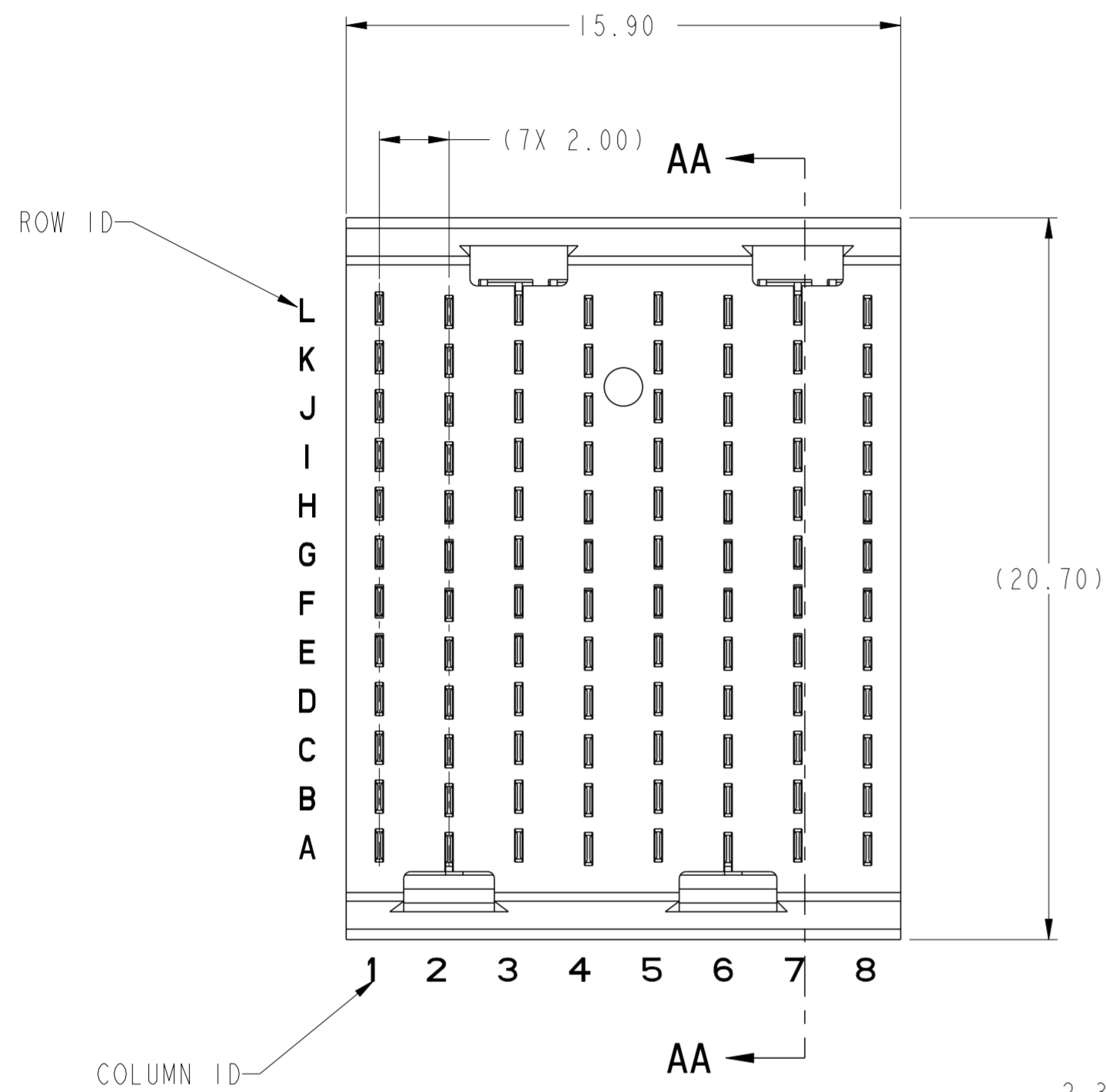

SECTION AA-AA

Amphenol
FCi

© 2016 APCI

spec ref	---	dr	Tao Zhan	2014/07/25	projection	MM	size	A2	scale	6:1
tolerance std	ASME Y14.5M	eng	Terry Luo	2020/09/08			ecn no	ELX-DG-38252-1		
TOLERANCES UNLESS OTHERWISE SPECIFIED		chr	-				rel level	Released		
surface	linear	0.X	±.3		product family	AirMax VSe		title AIRMAX VS2 RA HEADER 4 PAIR 96 POS 2MM 8 COL SMALL PRESS FIT, GXT+	rev C	sheet 1 of 3
		0.XX	±.10		cat. no.	-				
	angular	0°	±2°		diag no	10131108				

PDS: Rev :C

STATUS:Released

Printed: Sep 18, 2020

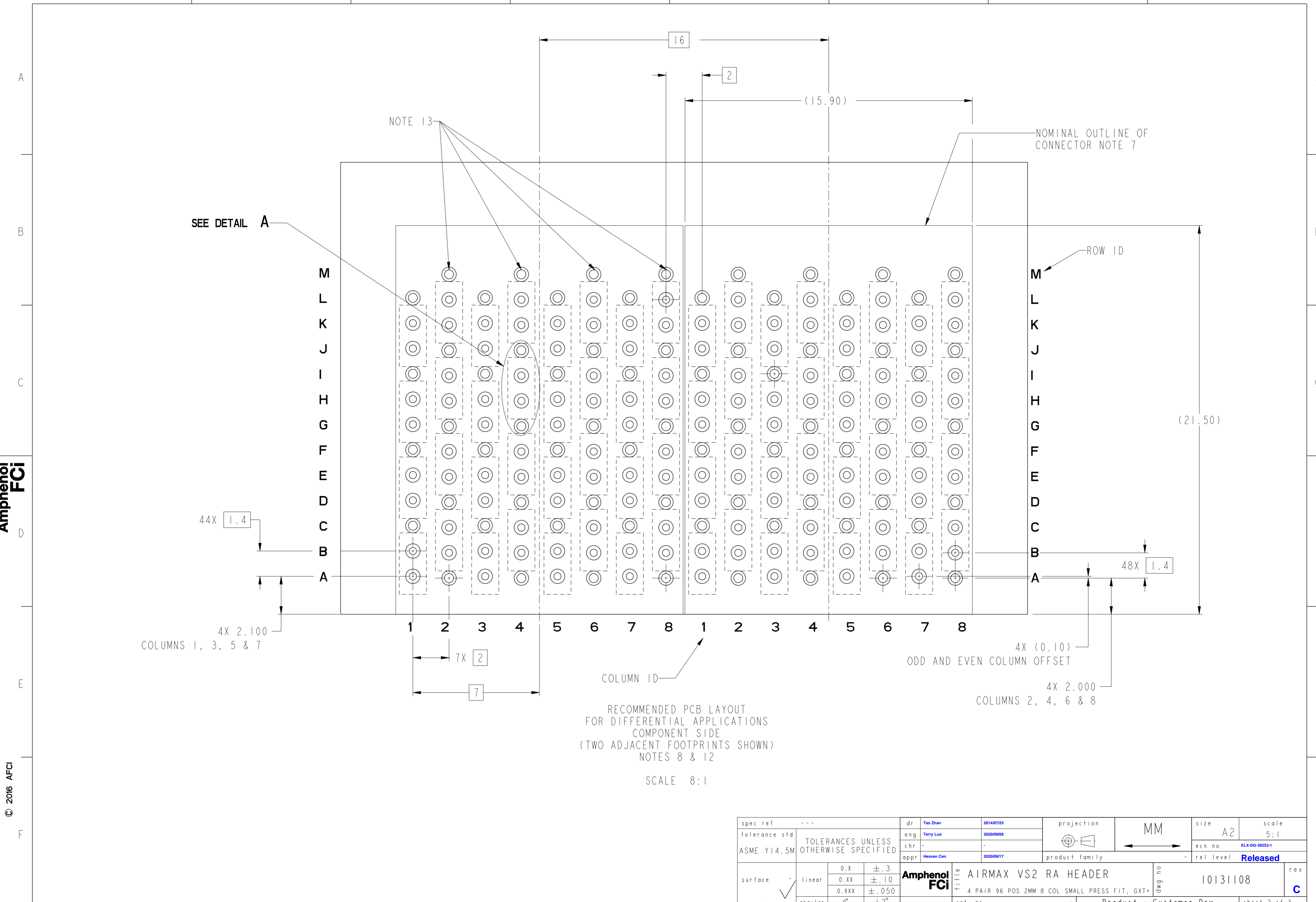

spec ref	---	dr	Tao Zhan	2014/07/25	projection	MM	size	A2	scale	5:1
tolerance std	ASME Y14.5M	eng	Terry Luo	2020/09/08			ecn no	ELX-DG-38252-1		
TOLERANCES UNLESS OTHERWISE SPECIFIED		chr	-	rel level			Released			
surface	-	appr	Heaven Cen	2020/09/17			product family	-		
linear	0.X ±.3 0.XX ±.10 0.XXX ±.050	Amphenol FCi		title		AIRMAX VS2 RA HEADER		dwg no	10131108	
angular	0° ±2°	cat. no.		Product - Customer Drw		sheet 2 of 3		rev	C	

PRODUCT NUMBER	PRESS-FIT TAIL PLATING TYPE	REMARK
10131108-101	TIN/LEAD ALLOY OVER NICKEL	1-SIDE PLATING CUSTOMER SPECIAL
10131108-101LF	TIN OVER NICKEL (LEAD FREE)	
10131108-102	TIN/LEAD ALLOY OVER NICKEL	2-SIDES PLATING
10131108-102LF	TIN OVER NICKEL (LEAD FREE)	

- 1 - CONNECTOR MATERIALS:
HOUSING: LCP, 20% MINIMUM GLASS, NATURAL, UL94-V0
IMLA PLASTIC: HIGH TEMP THERMOPLASTIC, BLACK, UL94-V0
CONTACT: COPPER ALLOY
ORGANIZER: HIGH TEMP THERMOPLASTIC, NATURAL, UL94-V0
- 2 - CONTACT PLATING:
SEPARABLE INTERFACE:
PERFORMANCE-BASED PLATING, QUALIFIED TO MEET THE REQUIREMENTS OF FCI PRODUCT SPECIFICATION GS-12-0956 INCLUDING TELCORDIA GR-1217-CORE (NOVEMBER 1995) CENTRAL OFFICE TEST SEQUENCE

PRESS-FIT TAILS: SEE TABLE
- 3 - PRODUCT SPECIFICATION: GS-12-0956
- 4 - APPLICATION SPECIFICATION: GS-20-0305
- 5 - PRODUCT MARKING, (PROTOTYPE, PART NUMBER & LOT CODE), ON THIS SURFACE.
- 6 - POSITIONS "F" OF ODD NUMBERED COLUMNS AND POSITIONS "G" OF EVEN NUMBERED COLUMNS CORRESPOND TO EARLY MATE HEADER PINS.
- 7 - CONNECTOR OUTLINE MAY BE SCREEN PRINTED ONTO CUSTOMER PCB TO BE USED AS A GUIDE FOR CONNECTOR PLACEMENT.
- 8 - REFER TO CUSTOMER DRAWING 10104444 FOR INFORMATION ON PCB HOLE DIAMETERS AND PLATING OPTIONS
- 9 - LEAD FREE PRODUCT MEETS THE EUROPEAN UNION DIRECTIVES & OTHER COUNTRY REGULATIONS AS DESCRIBED IN GS-22-008
- 10 - A Δ SYMBOL WILL BE NEXT TO ANY DIMENSION, VIEW, OR NOTE THAT HAS BEEN MODIFIED WITH THE CURRENT DRAWING REVISION.
- 11 - PACKAGING MEETS GS-14-920 LEAD FREE LABELING SPECIFICATION.
- 12 - GROUND CONTACTS (C, F, I & L IN ODD COLUMNS AND A, D, G & J IN EVEN COLUMNS) REQUIRE ($\varnothing 0.500$) FINISHED HOLES. SIGNAL LOCATIONS REQUIRE ($\varnothing 0.400$) FINISHED HOLES
- 13 - THESE OUTER VIAS (M) ARE OPTIONAL. WHILE NO CONNECTOR PINS ARE PRESSED INTO THESE HOLES WE RECOMMEND ($\varnothing 0.500$) FINISHED HOLES AT THESE LOCATIONS TO PROVIDE GROUND SYMMETRY THROUGH THE PCB.

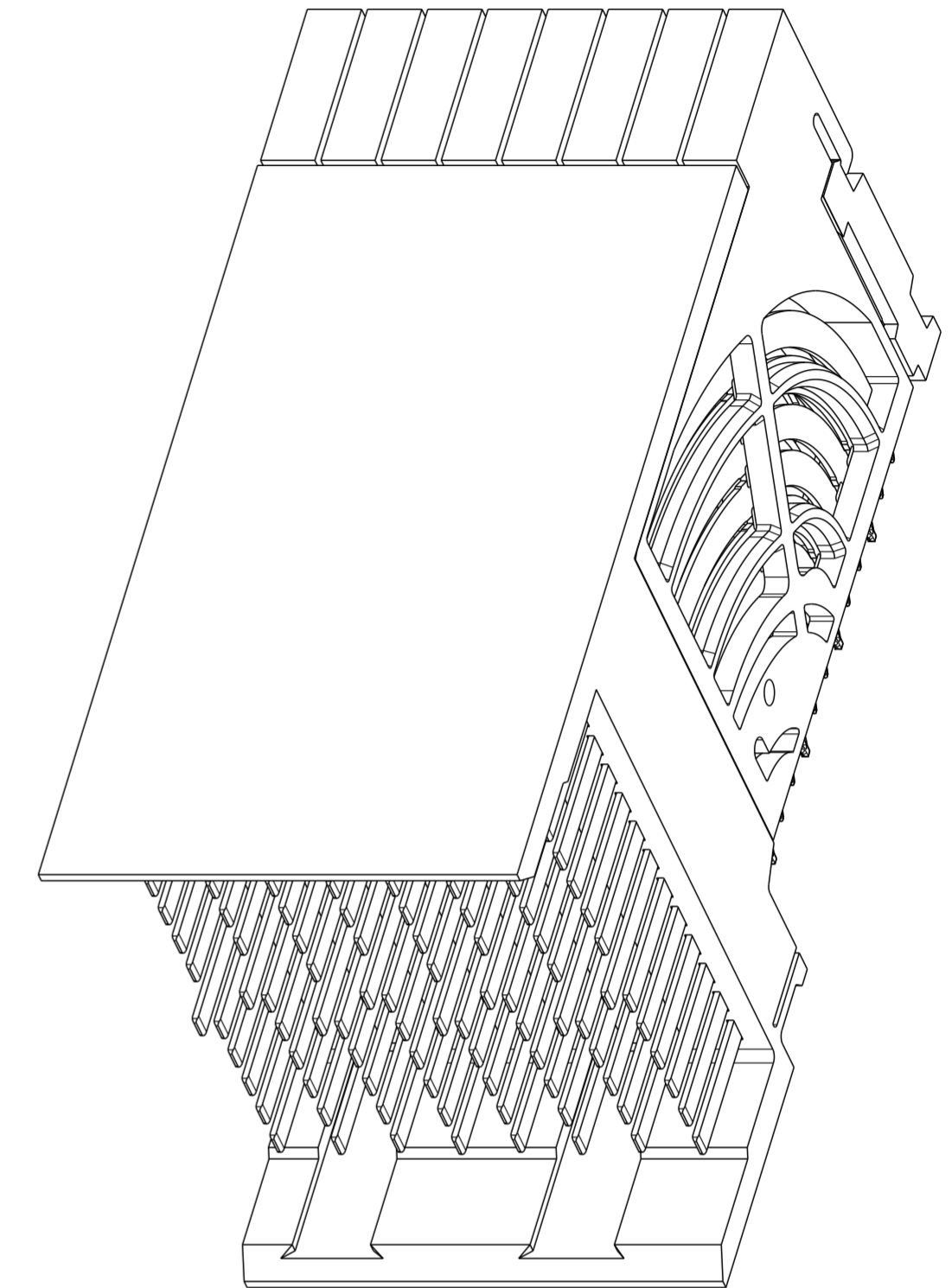

10131108-101 OR -101LF

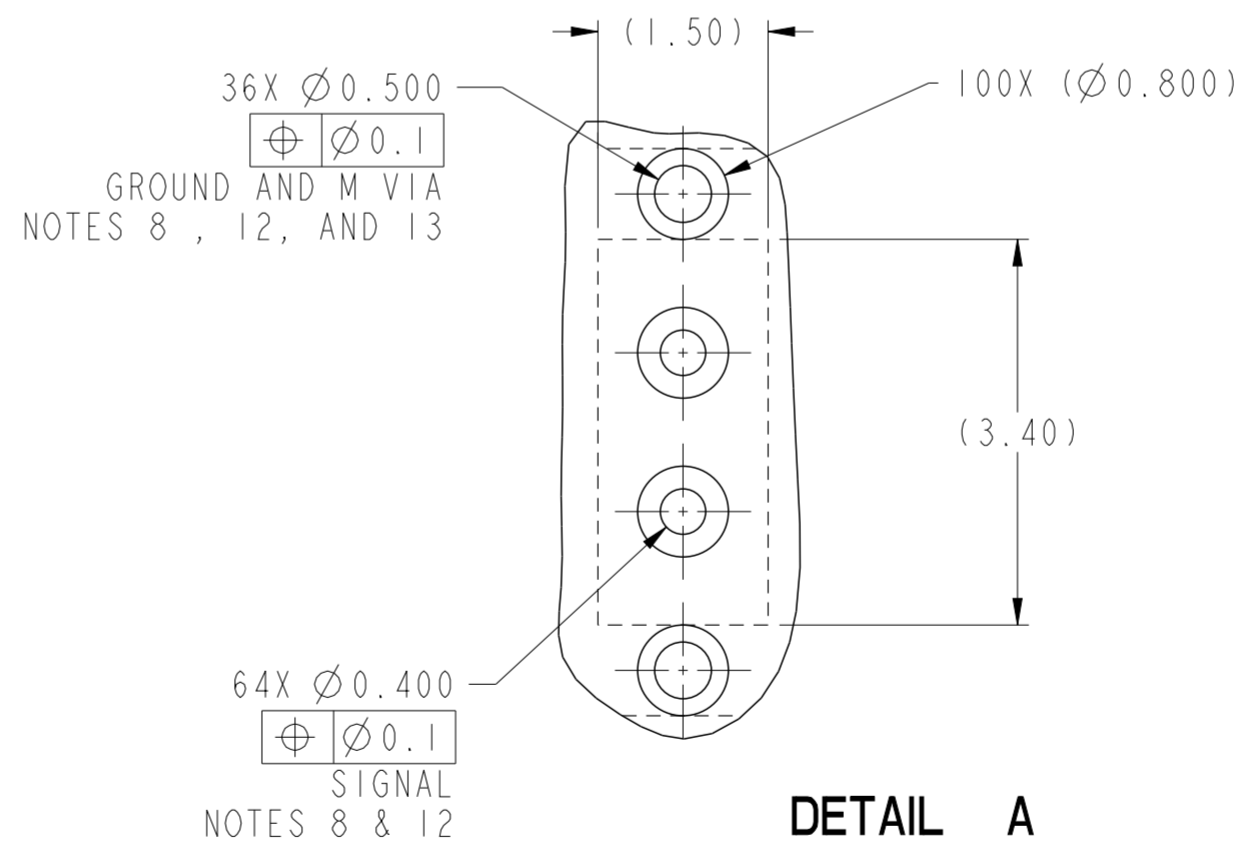

spec ref	---	dr	Tao Zhan	2014/07/25	projection	MM	size	A2	scale	5:1		
tolerance std	ASME Y14.5M	eng	Terry Luo	2020/09/08	chr	-	ecn no	ELX-DG-38252-1	rel level	Released		
TOLERANCES UNLESS OTHERWISE SPECIFIED		appr	Heaven Cen	2020/09/17	product family	-	rel level	Released				
surface	linear	0.X	$\pm .3$	Amphenol FCi	title		AIRMUX VS2 RA HEADER	4 PAIR 96 POS 2MM 8 COL SMALL PRESS FIT, GXT+	dwg no	10131108	rev	C
		0.XX	$\pm .10$		cat. no.		-		Product - Customer Drw	sheet 3 of 3		
	angular	0°	$\pm 2^\circ$									