



PL60208X

PCIe Octal, Ultra-Low Jitter, HCSL Frequency Synthesizer

General Description

The PL602081 and PL602082 are members of the PCI Express family of devices from Micrel and provide an extremely low-noise timing solution for PCI Express clock signals. They are based upon a unique synthesizer architecture that provides very low phase noise.

The devices operate from a 3.3V or 2.5V power supply and synthesize eight HCSL output clocks. The PL602081 synthesizes 25MHz, 100MHz, or 200MHz and the PL602082 synthesizes 25MHz, 125MHz, or 250MHz. The PL60208x devices accept a 25MHz crystal or LVCMOS reference clock.

Datasheets and support documentation are available on Micrel's web site at: www.micrel.com.

Block Diagram

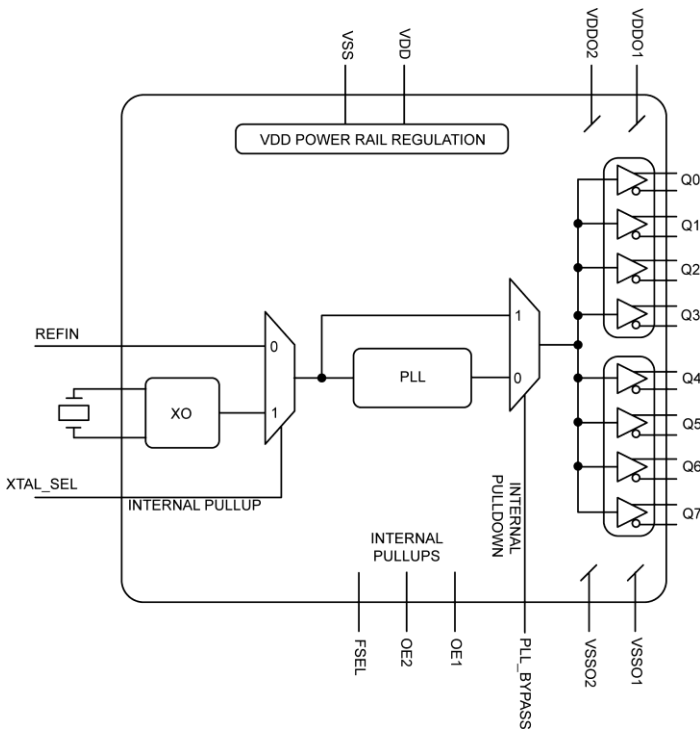

Features

- Generates eight HCSL clock outputs.
- PL602081 output frequencies: 25MHz, 100MHz, or 200MHz.
- PL602082 output frequencies: 25MHz, 125MHz, or 250MHz.
- 2.5V or 3.3V operating range.
- Typical phase jitter: 250fs for 12KHz to 20MHz.
- Compliant with PCI Express Gen1, Gen2, and Gen3.
- Industrial temperature range (-40°C to +85°C).
- RoHS and PFOS compliant.
- Available in 44-pin 7mm × 7mm QFN package.

Applications

- Servers
- Storage systems
- Switches and routers
- Gigabit Ethernet
- Set-top boxes/DVRs

Ordering Information⁽¹⁾

Part Number	Marking	Shipping	Junction Temperature Range	Package
PL602081UMG	PL602081UMG	Tray	-40° to +85°C	44-Pin QFN
PL602081UMG TR	PL602081UMG	Tape and Reel	-40° to +85°C	44-Pin QFN
PL602082UMG	PL602082UMG	Tray	-40° to +85°C	44-Pin QFN
PL602082UMG TR	PL602082UMG	Tape and Reel	-40° to +85°C	44-Pin QFN

Note:

1. Devices are RoHS and PFOS compliant.

Pin Configuration

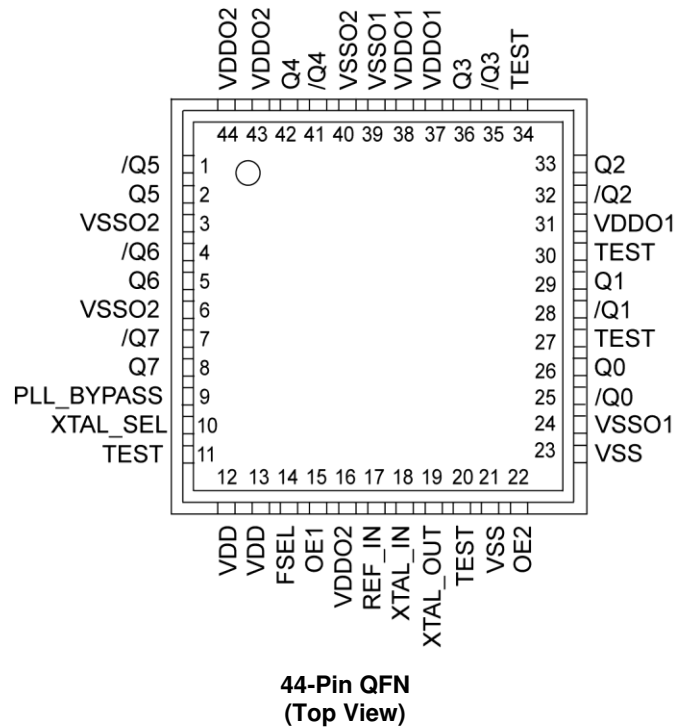

Pin Description

Pin Number	Pin Name	Pin Type	Pin Level	Pin Name
1, 2	/Q5, Q5	O, (DIF)	HCSL	Differential clock output.
4, 5	/Q6, Q6			
7, 8	/Q7, Q7			
25, 26	/Q0, Q0			
28, 29	/Q1, Q1			
32, 33	/Q2, Q2			
35, 36	/Q3, Q3			
41, 42	/Q4, Q4			
14	FSEL	I, (SE)	LVC MOS	Frequency select, 1 = 100MHz, 0 = 200MHz, 45KΩ pull-up.
12, 13	VDD	PWR		Power supply.
31, 37, 38	VDDO1	PWR		Power supply for outputs Q0 – Q3.
16, 43, 44	VDDO2	PWR		Power supply for outputs Q4 – Q7.
21, 23	VSS (exposed pad)	PWR		Core power supply ground. The exposed pad must be connected to the VSS ground plane.
24, 39	VSSO1	PWR		Power supply ground for outputs Q0 – Q3.
3, 6, 40	VSSO2	PWR		Power supply ground for outputs Q4 – Q7.

Pin Description (Continued)

Pin Number	Pin Name	Pin Type	Pin Level	Pin Name
9	PLL_BYPASS	I, (SE)	LVC MOS	PLL bypass, selects output source. 0 = normal PLL operation 1 = output from input reference clock or crystal 45K Ω pull down
10	XTAL_SEL	I, (SE)	LVC MOS	Selects PLL input reference source 0 = REF_IN, 1 = XTAL, 45K Ω pull-up
11, 20, 27, 30, 34	TEST			Factory test pins. Do not connect anything to these pins.
17	REF_IN	I, (SE)	LVC MOS	Reference clock input
18	XTAL_IN	I, (SE)	10pF crystal	Crystal reference input, no load caps needed (see Figure 6)
19	XTAL_OUT	O, (SE)	10pF crystal	Crystal reference output, no load caps needed (see Figure 6)
15	OE1	I, (SE)	LVC MOS	Output enable, outputs Q0 – Q3 disable to tri-state, 0 = disabled, 1 = enabled, 45K Ω pull-up
22	OE2	I, (SE)	LVC MOS	Output enable, outputs Q4 – Q7 disable to tri-state, 0 = disabled, 1 = enabled, 45K Ω pull-up

Absolute Maximum Ratings⁽²⁾

Supply Voltage (V_{DD} , $V_{DDO1/2}$)	+4.6V
Input Voltage (V_{IN})	-0.50V to V_{DD} +0.5V
Lead Temperature (soldering, 20s)	260°C
Case Temperature	115°C
Storage Temperature (T_S)	-65°C to +150°C

Operating Ratings⁽³⁾

Supply Voltage (V_{DD} , $V_{DDO1/2}$)	+2.375V to +3.465V
Ambient Temperature (T_A)	-40°C to +85°C
Junction Thermal Resistance ⁽⁴⁾	
QFN (θ_{JA}) Still-Air	24°C/W
QFN (ψ_{JB}) Junction-to-Board	8°C/W

DC Electrical Characteristics⁽⁴⁾

$V_{DD} = V_{DDO1/2} = 3.3V \pm 5\%$ or $2.5V \pm 5\%$

$V_{DD} = 3.3V \pm 5\%$, $V_{DDO1/2} = 3.3V \pm 5\%$ or $2.5V \pm 5\%$

$T_A = -40^\circ\text{C}$ to $+85^\circ\text{C}$.

Symbol	Parameter	Condition	Min.	Typ.	Max.	Units
V_{DD} , $V_{DDO1/2}$	2.5V operating range		2.375	2.5	2.625	V
V_{DD} , $V_{DDO1/2}$	3.3V operating range		3.135	3.3	3.465	V
I_{DD}	Supply current $V_{DD} + V_{DDO}$	Eight outputs enabled, 100MHz Outputs 50Ω to V_{SS}		217	270	mA
		Eight outputs enabled, 200MHz Outputs 50Ω to V_{SS}		229	285	
		Four outputs enabled, 100MHz Outputs 50Ω to V_{SS} , OE1 or OE2 = 0		149	185	
		Four outputs enabled, 200MHz Outputs 50Ω to V_{SS} , OE1 or OE2 = 0		158	197	

HCSL DC Electrical Characteristics⁽⁴⁾

$V_{DD} = V_{DDO1/2} = 3.3V \pm 5\%$ or $2.5V \pm 5\%$

$V_{DD} = 3.3V \pm 5\%$, $V_{DDO1/2} = 3.3V \pm 5\%$ or $2.5V \pm 5\%$

$T_A = -40^\circ\text{C}$ to $+85^\circ\text{C}$. $R_L = 50\Omega$ to V_{SS}

Symbol	Parameter	Condition	Min.	Typ.	Max.	Units
V_{OH}	Output high voltage		660	700	850	mV
V_{OL}	Output low voltage		-150	0	27	mV
V_{CROSS}	Crossing point voltage		250	350	550	mV

LVCMOS (PLL_BYPASS, XTAL_SEL, FSEL, OE1, OE2) DC Electrical Characteristics⁽⁴⁾

$V_{DD} = 3.3V \pm 5\%$ or $2.5V \pm 5\%$, $T_A = -40^\circ C$ to $+85^\circ C$.

Symbol	Parameter	Condition	Min.	Typ.	Max.	Units
V_{IH}	Input high voltage		2		$V_{DD} + 0.3$	V
V_{iL}	Input low voltage		-0.3		0.8	V
I_{IH}	Input high current	$V_{DD} = V_{IN} = 3.465V$			150	μA
I_{iL}	Input low current	$V_{DD} = 3.465V, V_{IN} = 0V$	-150			μA

REF_IN DC Electrical Characteristics⁽⁴⁾

$V_{DD} = 3.3V \pm 5\%$ or $2.5V \pm 5\%$, $T_A = -40^\circ C$ to $+85^\circ C$.

Symbol	Parameter	Condition	Min.	Typ.	Max.	Units
V_{IH}	Input high voltage		1.1		$V_{DD} + 0.3$	V
V_{iL}	Input low voltage		-0.3		0.6	V
I_{IN}	Input current	$XTAL_SEL = V_{iL}, V_{IN} = 0V$ to V_{DD}	-5		5	μA
		$XTAL_SEL = V_{IH}, V_{IN} = V_{DD}$		20		

Crystal Characteristics

Parameter	Condition	Min.	Typ.	Max.	Units
Mode of oscillation	10pF load	Fundamental, parallel resonant			
Frequency			25		MHz
Equivalent series resistance (ESR)				50	Ω
Shunt capacitor, C0			2	5	pF
Correlation drive level			10	100	μW

AC Electrical Characteristics^(4, 6)

$V_{DD} = V_{DDO1/2} = 3.3V \pm 5\%$ or $2.5V \pm 5\%$

$V_{DD} = 3.3V \pm 5\%$, $V_{DDO1/2} = 3.3V \pm 5\%$ or $2.5V \pm 5\%$

$T_A = -40^\circ\text{C}$ to $+85^\circ\text{C}$. $R_L = 50\Omega$ to V_{SS}

Symbol	Parameter	Condition	Min.	Typ.	Max.	Units
T_R/T_F	HCSL output rise/fall time	20% - 80%	150	300	450	ps
ODC	Output duty cycle		48	50	52	%
T_{SKEW}	Output-to-output skew	Note 7			45	ps
T_{LOCK}	PLL lock time				20	ms
$T_{jit}(\emptyset)$	RMS phase jitter ⁽⁸⁾	100MHz or 125MHz Integration range (12kHz – 20MHz) Integration range (10kHz – 1.5MHz) Integration range (1.5MHz – Nyquist) 200MHz or 250MHz Integration range (12kHz – 20MHz) Integration range (10kHz – 1.5MHz) Integration range (1.5MHz – Nyquist)		254 220 142 253 222 112		fs

Notes:

- Exceeding the absolute maximum ratings may damage the device.
- The device is not guaranteed to function outside its operating ratings.
- Package thermal resistance assumes exposed pad is soldered (or equivalent) to the devices most negative potential on the PCB.
- Specification for packaged product only
- All phase noise measurements were taken with an Agilent 5052B phase noise system.
- Defined as skew between outputs at the same supply voltage and with equal load conditions; Measured at the output differential crossing points.
- Measured using 25MHz crystal as the input reference source. If using an external reference input, use a low phase noise source. With an external reference, the phase noise will follow the input source phase noise up to about 1MHz.

Truth Tables

PLL_BYPASS	XTAL_SEL	OE2	OE1	INPUT	OUTPUT
0	–	1	1	–	PLL
1	–	1	1	–	XTAL/REF_IN
–	0	1	1	REF_IN	–
–	1	1	1	XTAL	–
–	–	0	1	–	Q4-Q7 Tri-state
–	–	1	0	–	Q0-Q3 Tri-state

FSEL	PLL_BYPASS	Output Frequency (MHz)	
		PL602081	PL602082
0	0	200	250
1	0	100	125
X	1	25	25

Phase Noise Plots

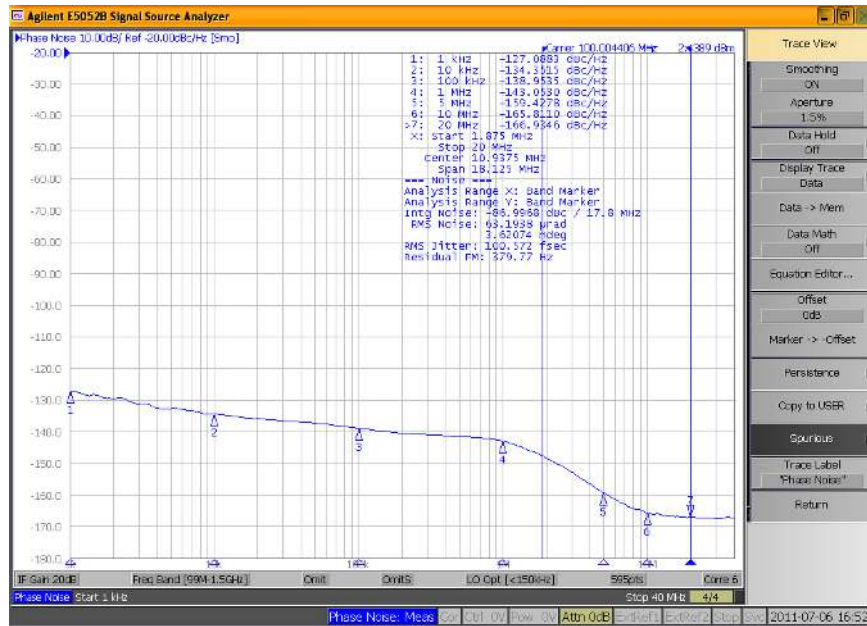

Phase Noise Plot: 100MHz, 1.875MHz – 20MHz 101fs

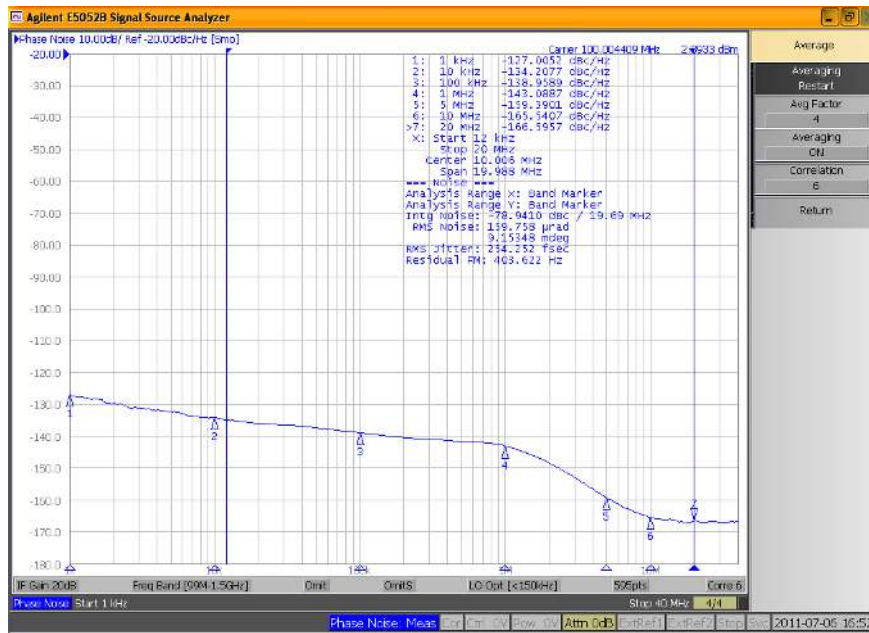

Phase Noise Plot: 100MHz, 12kHz – 20MHz 254fs

Phase Noise Plots (Continued)

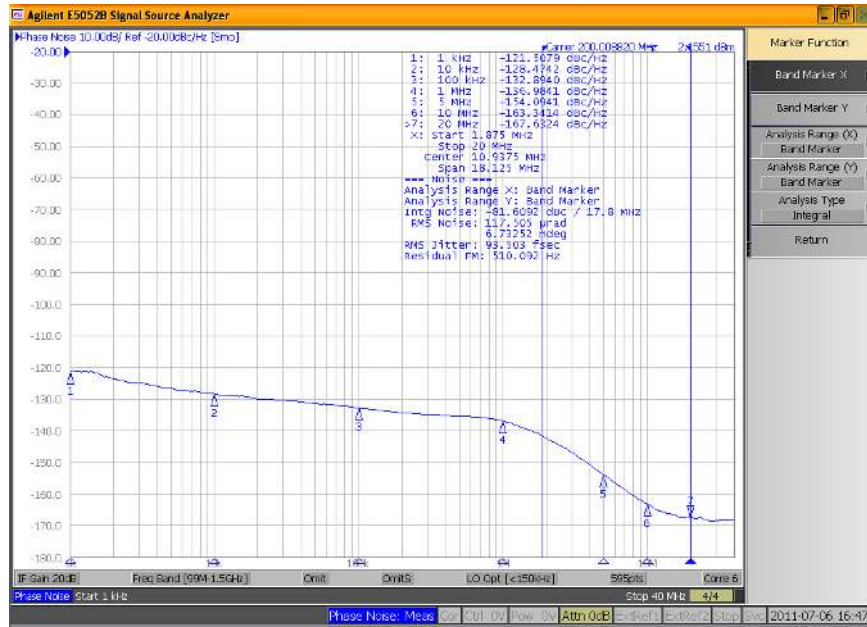

Phase Noise Plot: 200MHz, 1.875MHz – 20MHz 94fs

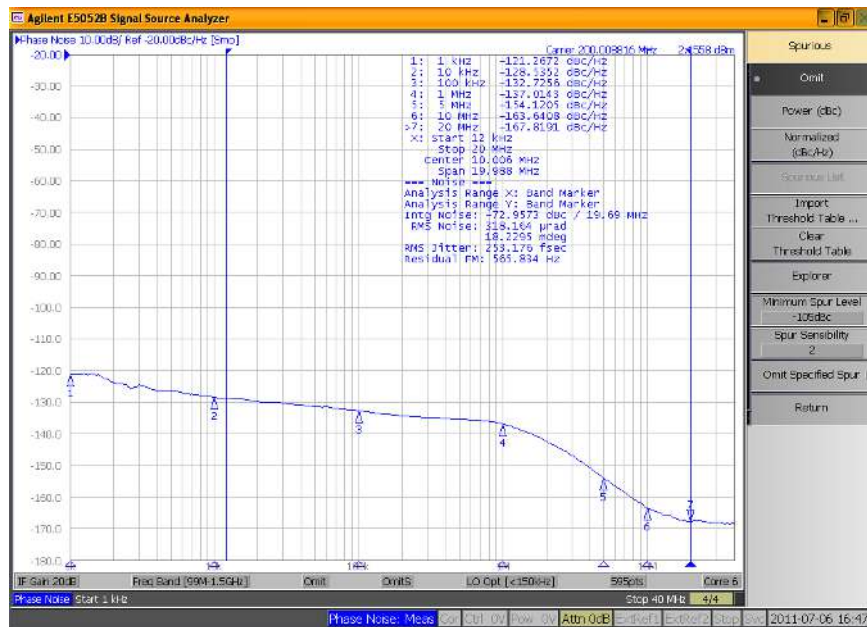

Phase Noise Plot: 200MHz, 12kHz – 20MHz 253fs

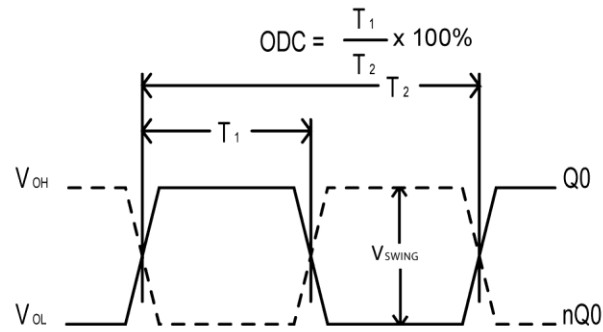

Figure 1. Duty Cycle Timing

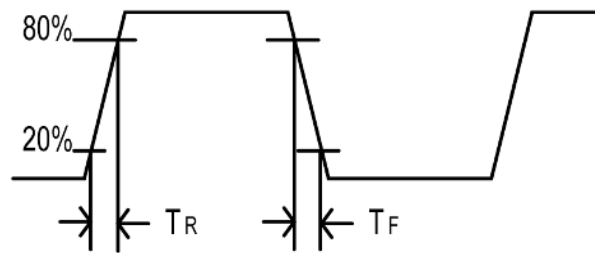

Figure 2. All Outputs Rise/Fall Time

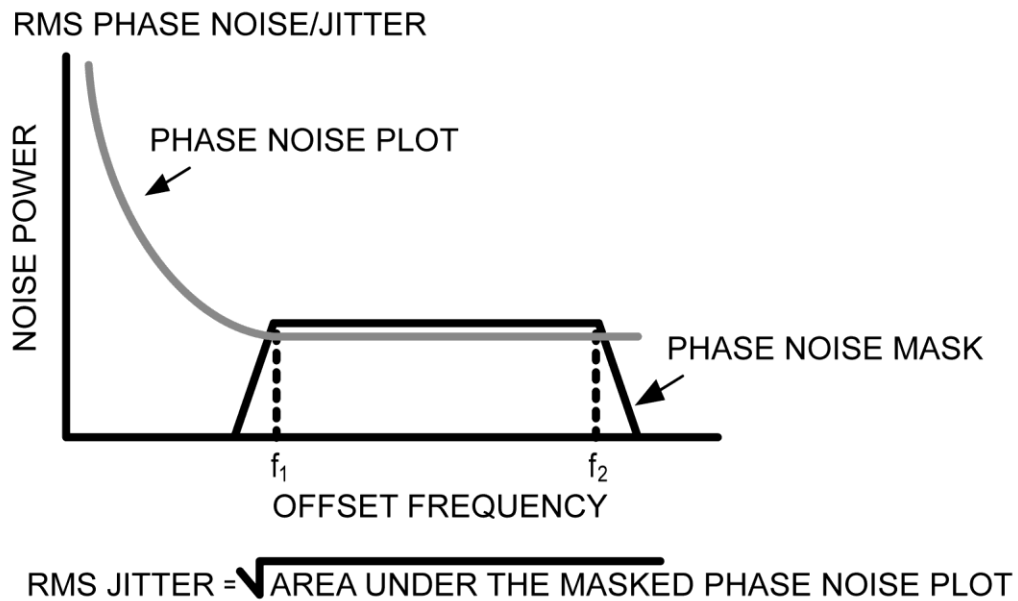

Figure 3. RMS Phase/Noise Jitter

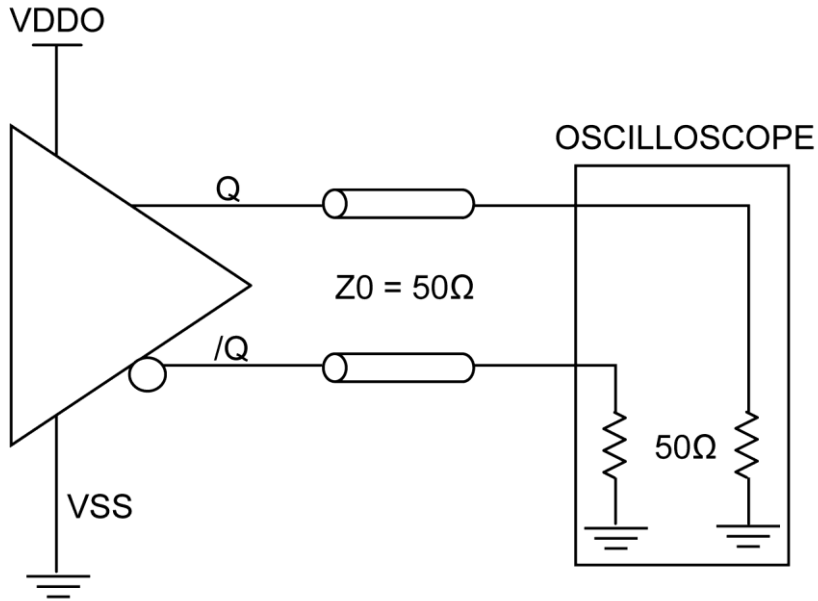

Figure 4. HCSL Output Load and Test Circuit

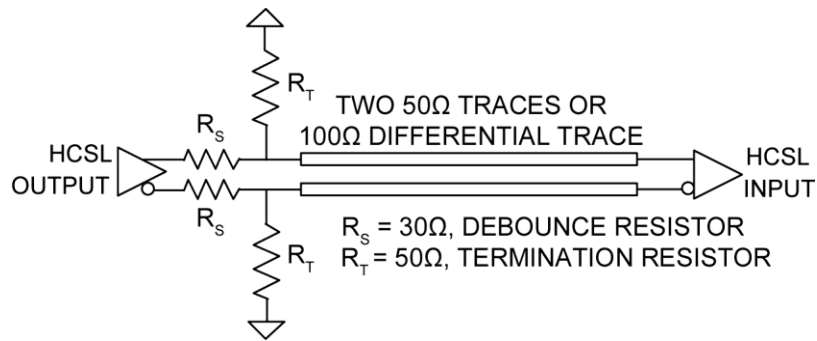

Figure 5. HCSL recommended application termination (source terminated)

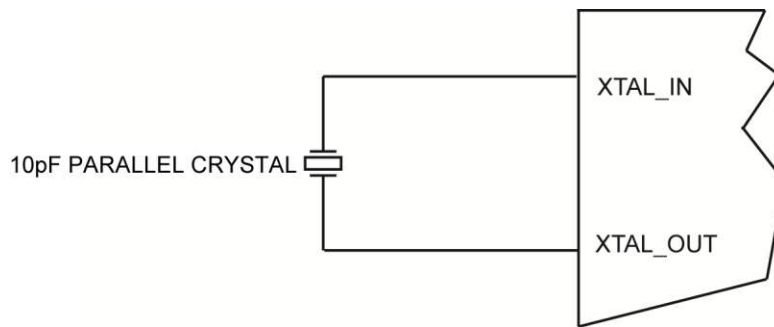

Figure 6. Crystal Input Interface

Application Information

Input Reference

When operating with a crystal input reference, do not apply a switching signal to REF_IN.

Crystal Layout

Keep the layers under the crystal as open as possible and do not place switching signals or noisy supplies under the crystal.

Crystal load capacitance is built inside the die so no external capacitance is needed. See the Selecting a Quartz crystal for the *Clockworks Flex I Family of Precision Synthesizers* application note for further details.

Contact Micrel's TCG applications group if you need assistance on selecting a suitable crystal for your application at: hbwhelp@micrel.com.

Power Supply Decoupling

Place the smallest value decoupling capacitor (4.7nF above) between the VDD and VSS pins, as close as possible to those pins and at the same side of the PCB as the IC. The shorter the physical path from VDD to capacitor and back from capacitor to VSS, the more effective the decoupling. Use one 4.7nF capacitor for each VDD pin on the PL60208X.

HCSL Outputs

HCSL outputs are to be terminated with 50Ω to VSS. For best performance load all outputs. If you want to AC-couple or change the termination, contact Micrel's application group at: hbwhelp@micrel.com.

Package Information⁽⁹⁾

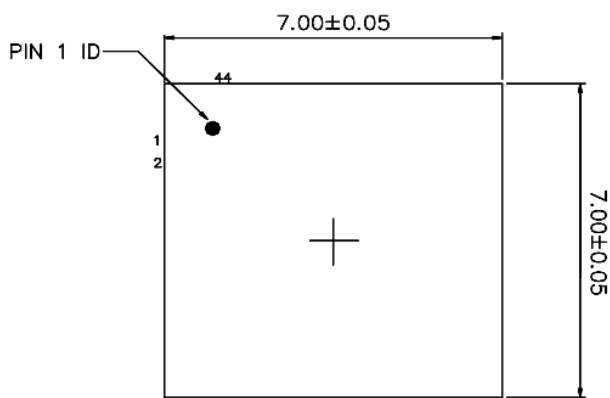

TOP VIEW
NOTE 1, 2, 3

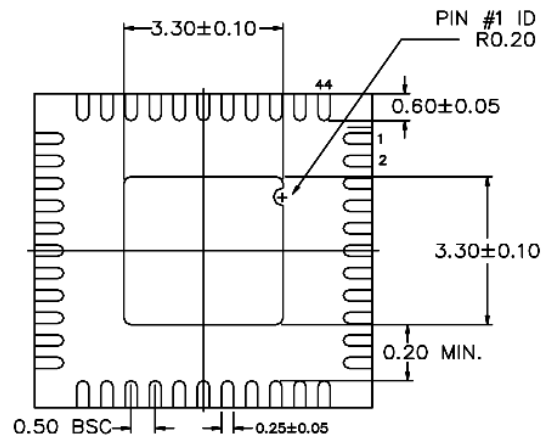

BOTTOM VIEW
NOTE 1, 2, 3

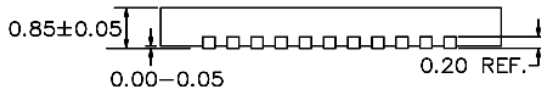

SIDE VIEW
NOTE 1, 2, 3

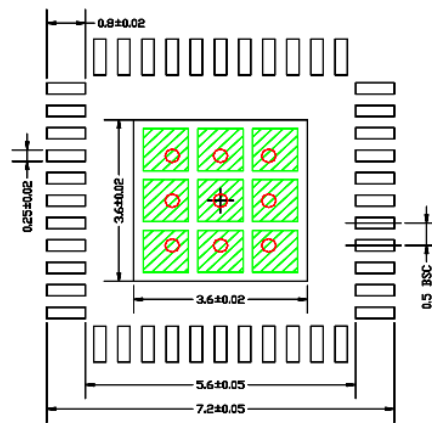

RECOMMENDED LAND PATTERN
NOTE 4, 5

NOTE:

1. MAX PACKAGE WARPAGE IS 0.05 MM
2. MAX ALLOWABLE BURR IS 0.076MM IN ALL DIRECTIONS
3. PIN #1 IS ON TOP WILL BE LASER MARKED
4. RED CIRCLE IN LAND PATTERN INDICATE THERMAL VIA. SIZE SHOULD BE 0.30-0.3MM IN DIAMETER AND SHOULD BE CONNECTED TO GND FOR MAX THERMAL PERFORMANCE.
5. GREEN RECTANGLES (SHADED AREA) REPRESENT SOLDER STENCIL OPENING ON EXPOSED PAD AREA. RECOMMENDED SIZE IS 0.93x0.93MM, SPACING IS 0.2MM

44-Pin QFN

Note:

9. Package information is correct as of the publication date. For updates and most current information, go to www.micrel.com.

MICREL, INC. 2180 FORTUNE DRIVE SAN JOSE, CA 95131 USA
TEL +1 (408) 944-0800 FAX +1 (408) 474-1000 WEB <http://www.micrel.com>

Micrel makes no representations or warranties with respect to the accuracy or completeness of the information furnished in this data sheet. This information is not intended as a warranty and Micrel does not assume responsibility for its use. Micrel reserves the right to change circuitry, specifications and descriptions at any time without notice. No license, whether express, implied, arising by estoppel or otherwise, to any intellectual property rights is granted by this document. Except as provided in Micrel's terms and conditions of sale for such products, Micrel assumes no liability whatsoever, and Micrel disclaims any express or implied warranty relating to the sale and/or use of Micrel products including liability or warranties relating to fitness for a particular purpose, merchantability, or infringement of any patent, copyright or other intellectual property right.

Micrel Products are not designed or authorized for use as components in life support appliances, devices or systems where malfunction of a product can reasonably be expected to result in personal injury. Life support devices or systems are devices or systems that (a) are intended for surgical implant into the body or (b) support or sustain life, and whose failure to perform can be reasonably expected to result in a significant injury to the user. A Purchaser's use or sale of Micrel Products for use in life support appliances, devices or systems is a Purchaser's own risk and Purchaser agrees to fully indemnify Micrel for any damages resulting from such use or sale.

© 2013 Micrel, Incorporated.