

To all our customers

Regarding the change of names mentioned in the document, such as Hitachi Electric and Hitachi XX, to Renesas Technology Corp.

The semiconductor operations of Mitsubishi Electric and Hitachi were transferred to Renesas Technology Corporation on April 1st 2003. These operations include microcomputer, logic, analog and discrete devices, and memory chips other than DRAMs (flash memory, SRAMs etc.) Accordingly, although Hitachi, Hitachi, Ltd., Hitachi Semiconductors, and other Hitachi brand names are mentioned in the document, these names have in fact all been changed to Renesas Technology Corp. Thank you for your understanding. Except for our corporate trademark, logo and corporate statement, no changes whatsoever have been made to the contents of the document, and these changes do not constitute any alteration to the contents of the document itself.

Renesas Technology Home Page: <http://www.renesas.com>

Renesas Technology Corp.
Customer Support Dept.
April 1, 2003

Cautions

Keep safety first in your circuit designs!

1. Renesas Technology Corporation puts the maximum effort into making semiconductor products better and more reliable, but there is always the possibility that trouble may occur with them. Trouble with semiconductors may lead to personal injury, fire or property damage.

Remember to give due consideration to safety when making your circuit designs, with appropriate measures such as (i) placement of substitutive, auxiliary circuits, (ii) use of nonflammable material or (iii) prevention against any malfunction or mishap.

Notes regarding these materials

1. These materials are intended as a reference to assist our customers in the selection of the Renesas Technology Corporation product best suited to the customer's application; they do not convey any license under any intellectual property rights, or any other rights, belonging to Renesas Technology Corporation or a third party.
2. Renesas Technology Corporation assumes no responsibility for any damage, or infringement of any third-party's rights, originating in the use of any product data, diagrams, charts, programs, algorithms, or circuit application examples contained in these materials.
3. All information contained in these materials, including product data, diagrams, charts, programs and algorithms represents information on products at the time of publication of these materials, and are subject to change by Renesas Technology Corporation without notice due to product improvements or other reasons. It is therefore recommended that customers contact Renesas Technology Corporation or an authorized Renesas Technology Corporation product distributor for the latest product information before purchasing a product listed herein.
The information described here may contain technical inaccuracies or typographical errors.
Renesas Technology Corporation assumes no responsibility for any damage, liability, or other loss rising from these inaccuracies or errors.
Please also pay attention to information published by Renesas Technology Corporation by various means, including the Renesas Technology Corporation Semiconductor home page (<http://www.renesas.com>).
4. When using any or all of the information contained in these materials, including product data, diagrams, charts, programs, and algorithms, please be sure to evaluate all information as a total system before making a final decision on the applicability of the information and products. Renesas Technology Corporation assumes no responsibility for any damage, liability or other loss resulting from the information contained herein.
5. Renesas Technology Corporation semiconductors are not designed or manufactured for use in a device or system that is used under circumstances in which human life is potentially at stake. Please contact Renesas Technology Corporation or an authorized Renesas Technology Corporation product distributor when considering the use of a product contained herein for any specific purposes, such as apparatus or systems for transportation, vehicular, medical, aerospace, nuclear, or undersea repeater use.
6. The prior written approval of Renesas Technology Corporation is necessary to reprint or reproduce in whole or in part these materials.
7. If these products or technologies are subject to the Japanese export control restrictions, they must be exported under a license from the Japanese government and cannot be imported into a country other than the approved destination.
Any diversion or reexport contrary to the export control laws and regulations of Japan and/or the country of destination is prohibited.
8. Please contact Renesas Technology Corporation for further details on these materials or the products contained therein.

Hitachi Single-Chip Microcomputer

H8/3297 Series

H8/3297
HD6473297, HD6433297

H8/3296
HD6433296

H8/3294
HD6473294, HD6433294

H8/3292
HD6433292

Hardware Manual

The revision list can be viewed directly by clicking the title page.

The revision list summarizes the locations of revisions and additions. Details should always be checked by referring to the relevant text.

3rd Edition

When using this document, keep the following in mind:

1. This document may, wholly or partially, be subject to change without notice.
2. All rights are reserved: No one is permitted to reproduce or duplicate, in any form, the whole or part of this document without Hitachi's permission.
3. Hitachi will not be held responsible for any damage to the user that may result from accidents or any other reasons during operation of the user's unit according to this document.
4. Circuitry and other examples described herein are meant merely to indicate the characteristics and performance of Hitachi's semiconductor products. Hitachi assumes no responsibility for any intellectual property claims or other problems that may result from applications based on the examples described herein.
5. No license is granted by implication or otherwise under any patents or other rights of any third party or Hitachi, Ltd.
6. **MEDICAL APPLICATIONS:** Hitachi's products are not authorized for use in **MEDICAL APPLICATIONS** without the written consent of the appropriate officer of Hitachi's sales company. Such use includes, but is not limited to, use in life support system. Buyers of Hitachi's products are requested to notify the relevant hitachi sales offices when planning to use the products in **MEDICAL APPLICATIONS**.

Preface

The H8/3297 Series is a series of high-performance microcontrollers with a fast H8/300 CPU core and a set of on-chip supporting functions optimized for embedded control. These include ROM, RAM, three types of timers, a serial communication interface, A/D converter, I/O ports, and other functions needed in control system configurations, so that compact, high-performance systems can be implemented easily. The series includes the H8/3297 with 60-kbyte ROM and 2-kbyte RAM, the H8/3296 with 48-kbyte ROM and 2-kbyte RAM, H8/3294 with 32-kbyte ROM and 1-kbyte RAM, and the H8/3292 with 16-kbyte ROM and 512-byte RAM.

The entire H8/3297 Series is available in mask-ROM versions. The H8/3297 and H8/3294 are also available in ZTAT™* (zero turn-around time) versions, providing a quick and flexible response to conditions from ramp-up through full-scale volume production, even for applications with frequently-changing specifications.

This manual describes the hardware of the H8/3297 Series. Refer to the *H8/300 Series Programming Manual* for a detailed description of the instruction set.

Note: * ZTAT™ is a registered trademark of Hitachi, Ltd.

Main Revisions and Additions in this Edition

Page	Item		Revisions
4	Table 1-1	Features	Table amended
14	Table 1-3	Pin Functions	Table amended
37, 38	Notes on Bit Manipulation Instructions		Description amended
69	Figure 4-3	Block Diagram of Interrupt Controller	Figure amended
71	Figure 4-4	Hardware Interrupt-Handling Sequence	Flow amended
90	6.2	Oscillator Circuit (2) ②	Description amended
113	Table 7-9	Port 4 Pin Functions	Table amended
133	Table 7-15	Port 7 Register	Table amended
		Port 7 Input Register (P7PIN)	Description amended
184	Bit 7—Overflow Flag (OVF)		Table amended
	Bit 6—Timer Mode Select		
202 to 205	Table 11-3	Examples of BRR Settings in Asynchronous Mode (When $\phi_P = \emptyset$)	Description amended Whole table replaced
206	Table 11-4	Examples of BRR Settings in Synchronous Mode (When $\phi_P = \emptyset$)	Description amended Whole table replaced
223	Figure 11-11	Example of SCI Receive Operation	Figure amended
228	Figure 11-14	Example of SCI Transmit Operation	Figure amended
231	Figure 11-16	Example of SCI Receive Operation	Figure amended
254	13.2.2	Single-Chip Mode (Mode 3)	Note added
269	15.1.1	System Control Register (SYSCR)	Note Deleted
300 to 302	Table A-1	Instruction Set	Table amended
317	B.1	Addresses	Table amended
340	TCR—Timer Control Register		Table amended
355	Figure C-4 (a)	Port 4 Block Diagram (Pin P4 ₀)	Figure amended
363	Figure C-6 (a)	Port 6 Block Diagram (Pin P6 ₀)	Figure amended
364	Figure C-6 (b)	Port 6 Block Diagram (Pin P6 ₁)	Figure amended
365	Figure C-6 (c)	Port 6 Block Diagram (Pin P6 ₂)	Figure amended
366	Figure C-6 (d)	Port 6 Block Diagram (Pins P6 ₃ and P6 ₅)	Figure amended
367	Figure C-6 (e)	Port 6 Block Diagram (Pin P6 ₄)	Figure amended
368	Figure C-6 (f)	Port 6 Block Diagram (Pin P6 ₆)	Figure amended
369	Figure C-6 (g)	Port 6 Block Diagram (Pin P6 ₇)	Figure amended

Contents

Section 1	Overview.....	1
1.1	Overview	1
1.2	Block Diagram.....	5
1.3	Pin Assignments and Functions.....	6
1.3.1	Pin Arrangement.....	6
1.3.2	Pin Functions	9
Section 2	CPU	17
2.1	Overview	17
2.1.1	Features.....	17
2.1.2	Address Space.....	18
2.1.3	Register Configuration.....	18
2.2	Register Descriptions.....	19
2.2.1	General Registers.....	19
2.2.2	Control Registers	19
2.2.3	Initial Register Values	20
2.3	Data Formats.....	21
2.3.1	Data Formats in General Registers	22
2.3.2	Memory Data Formats	23
2.4	Addressing Modes	24
2.4.1	Addressing Mode.....	24
2.4.2	Calculation of Effective Address.....	26
2.5	Instruction Set.....	30
2.5.1	Data Transfer Instructions	31
2.5.2	Arithmetic Operations	33
2.5.3	Logic Operations	34
2.5.4	Shift Operations	34
2.5.5	Bit Manipulations	36
2.5.6	Branching Instructions.....	40
2.5.7	System Control Instructions	42
2.5.8	Block Data Transfer Instruction	43
2.6	CPU States.....	45
2.6.1	Overview.....	45
2.6.2	Program Execution State	46
2.6.3	Exception-Handling State	46
2.6.4	Power-Down State.....	46
2.7	Access Timing and Bus Cycle.....	47
2.7.1	Access to On-Chip Memory (RAM and ROM)	47
2.7.2	Access to On-Chip Register Field and External Devices	49

Section 3	MCU Operating Modes and Address Space	53
3.1	Overview	53
3.1.1	Mode Selection	53
3.1.2	Mode and System Control Registers	54
3.2	System Control Register (SYSCR).....	54
3.3	Mode Control Register (MDCR).....	56
3.4	Address Space Map in Each Operating Mode	57
Section 4	Exception Handling.....	61
4.1	Overview	61
4.2	Reset	61
4.2.1	Overview.....	61
4.2.2	Reset Sequence	61
4.2.3	Disabling of Interrupts after Reset.....	64
4.3	Interrupts	64
4.3.1	Overview.....	64
4.3.2	Interrupt-Related Registers.....	66
4.3.3	External Interrupts	68
4.3.4	Internal Interrupts	68
4.3.5	Interrupt Handling	69
4.3.6	Interrupt Response Time.....	74
4.3.7	Precaution	75
4.4	Note on Stack Handling.....	76
Section 5	Wait-State Controller	77
5.1	Overview	77
5.1.1	Features.....	77
5.1.2	Block Diagram.....	77
5.1.3	Input/Output Pins.....	78
5.1.4	Register Configuration.....	78
5.2	Register Description	78
5.2.1	Wait-State Control Register (WSCR).....	78
5.3	Wait Modes.....	80
Section 6	Clock Pulse Generator.....	83
6.1	Overview	83
6.1.1	Block Diagram.....	83
6.1.2	Wait-State Control Register (WSCR).....	84
6.2	Oscillator Circuit	85
6.3	Duty Adjustment Circuit.....	90
6.4	Prescaler	90

Section 7	I/O Ports	91
7.1	Overview	91
7.2	Port 1	93
7.2.1	Overview.....	93
7.2.2	Register Configuration and Descriptions.....	94
7.2.3	Pin Functions in Each Mode.....	96
7.2.4	Input Pull-Up Transistors	98
7.3	Port 2	99
7.3.1	Overview.....	99
7.3.2	Register Configuration and Descriptions.....	100
7.3.3	Pin Functions in Each Mode.....	102
7.3.4	Input Pull-Up Transistors	105
7.4	Port 3	106
7.4.1	Overview.....	106
7.4.2	Register Configuration and Descriptions.....	107
7.4.3	Pin Functions in Each Mode.....	109
7.4.4	Input Pull-Up Transistors	110
7.5	Port 4	111
7.5.1	Overview.....	111
7.5.2	Register Configuration and Descriptions.....	112
7.5.3	Pin Functions	113
7.6	Port 5	115
7.6.1	Overview.....	115
7.6.2	Register Configuration and Descriptions.....	115
7.6.3	Pin Functions	117
7.7	Port 6	118
7.7.1	Overview.....	118
7.7.2	Register Configuration and Descriptions.....	119
7.7.3	Pin Functions	121
7.8	Port 7	123
7.8.1	Overview.....	123
7.8.2	Register Configuration and Descriptions.....	124
Section 8	16-Bit Free-Running Timer	125
8.1	Overview	125
8.1.1	Features.....	125
8.1.2	Block Diagram.....	126
8.1.3	Input and Output Pins	127
8.1.4	Register Configuration.....	127
8.2	Register Descriptions.....	128
8.2.1	Free-Running Counter (FRC).....	128
8.2.2	Output Compare Registers A and B (OCRA and OCRB).....	129
8.2.3	Input Capture Registers A to D (ICRA to ICRD).....	129

8.2.4	Timer Interrupt Enable Register (TIER).....	131
8.2.5	Timer Control/Status Register (TCSR)	133
8.2.6	Timer Control Register (TCR).....	135
8.2.7	Timer Output Compare Control Register (TOCR).....	137
8.3	CPU Interface	139
8.4	Operation	142
8.4.1	FRC Incrementation Timing.....	142
8.4.2	Output Compare Timing.....	144
8.4.3	FRC Clear Timing	145
8.4.4	Input Capture Timing	146
8.4.5	Timing of Input Capture Flag (ICF) Setting.....	149
8.4.6	Setting of Output Compare Flags A and B (OCFA and OCFB)	150
8.4.7	Setting of FRC Overflow Flag (OVF).....	151
8.5	Interrupts	151
8.6	Sample Application	152
8.7	Usage Notes	153
Section 9	8-Bit Timers.....	159
9.1	Overview	159
9.1.1	Features.....	159
9.1.2	Block Diagram.....	160
9.1.3	Input and Output Pins	161
9.1.4	Register Configuration.....	161
9.2	Register Descriptions.....	162
9.2.1	Timer Counter (TCNT).....	162
9.2.2	Time Constant Registers A and B (TCORA and TCORB)	162
9.2.3	Timer Control Register (TCR).....	163
9.2.4	Timer Control/Status Register (TCSR)	166
9.2.5	Serial/Timer Control Register (STCR).....	168
9.3	Operation	169
9.3.1	TCNT Incrementation Timing.....	169
9.3.2	Compare Match Timing.....	171
9.3.3	External Reset of TCNT	173
9.3.4	Setting of TCSR Overflow Flag (OVF).....	173
9.4	Interrupts	174
9.5	Sample Application	174
9.6	Usage Notes	175
9.6.1	Contention between TCNT Write and Clear	175
9.6.2	Contention between TCNT Write and Increment	176
9.6.3	Contention between TCOR Write and Compare-Match	177
9.6.4	Contention between Compare-Match A and Compare-Match B	178
9.6.5	Incrementation Caused by Changing of Internal Clock Source	178

Section 10	Watchdog Timer	181
10.1	Overview	181
10.1.1	Features.....	181
10.1.2	Block Diagram.....	182
10.1.3	Register Configuration.....	182
10.2	Register Descriptions.....	183
10.2.1	Timer Counter (TCNT).....	183
10.2.2	Timer Control/Status Register (TCSR)	183
10.2.3	Register Access.....	185
10.3	Operation	186
10.3.1	Watchdog Timer Mode.....	186
10.3.2	Interval Timer Mode.....	187
10.3.3	Setting the Overflow Flag.....	187
10.4	Usage Notes	188
10.4.1	Contention between TCNT Write and Increment.....	188
10.4.2	Changing the Clock Select Bits (CKS2 to CKS0).....	188
10.4.3	Recovery from Software Standby Mode	188
Section 11	Serial Communication Interface.....	189
11.1	Overview	189
11.1.1	Features.....	189
11.1.2	Block Diagram.....	190
11.1.3	Input and Output Pins	191
11.1.4	Register Configuration.....	191
11.2	Register Descriptions.....	192
11.2.1	Receive Shift Register (RSR)	192
11.2.2	Receive Data Register (RDR).....	192
11.2.3	Transmit Shift Register (TSR).....	192
11.2.4	Transmit Data Register (TDR)	193
11.2.5	Serial Mode Register (SMR)	193
11.2.6	Serial Control Register (SCR)	196
11.2.7	Serial Status Register (SSR)	199
11.2.8	Bit Rate Register (BRR)	202
11.2.9	Serial/Timer Control Register (STCR).....	207
11.3	Operation	208
11.3.1	Overview.....	208
11.3.2	Asynchronous Mode.....	210
11.3.3	Synchronous Mode	224
11.4	Interrupts	233
11.5	Usage Notes	233
Section 12	A/D Converter	237
12.1	Overview	237

12.1.1	Features.....	237
12.1.2	Block Diagram.....	238
12.1.3	Input Pins	239
12.1.4	Register Configuration.....	240
12.2	Register Descriptions.....	241
12.2.1	A/D Data Registers A to D (ADDRA to ADDRD).....	241
12.2.2	A/D Control/Status Register (ADCSR).....	242
12.2.3	A/D Control Register (ADCR).....	244
12.3	CPU Interface	245
12.4	Operation	246
12.4.1	Single Mode (SCAN = 0).....	246
12.4.2	Scan Mode (SCAN = 1).....	248
12.4.3	Input Sampling and A/D Conversion Time.....	250
12.4.4	External Trigger Input Timing.....	251
12.5	Interrupts	251
12.6	Usage Notes	252
Section 13 RAM		253
13.1	Overview	253
13.1.1	Block Diagram.....	253
13.1.2	RAM Enable Bit (RAME) in System Control Register (SYSCR).....	254
13.2	Operation	254
13.2.1	Expanded Modes (Modes 1 and 2).....	254
13.2.2	Single-Chip Mode (Mode 3).....	254
Section 14 ROM.....		255
14.1	Overview	255
14.1.1	Block Diagram.....	256
14.2	PROM Mode.....	257
14.2.1	PROM Mode Setup.....	257
14.2.2	Socket Adapter Pin Assignments and Memory Map.....	257
14.3	PROM Programming.....	260
14.3.1	Programming and Verifying.....	260
14.3.2	Notes on Programming.....	264
14.3.3	Reliability of Programmed Data.....	264
14.3.4	Erasing of Data	265
14.4	Handling of Windowed Packages.....	266
Section 15 Power-Down State		267
15.1	Overview	267
15.1.1	System Control Register (SYSCR).....	268
15.2	Sleep Mode	269
15.2.1	Transition to Sleep Mode.....	269

15.2.2	Exit from Sleep Mode.....	269
15.3	Software Standby Mode	270
15.3.1	Transition to Software Standby Mode.....	270
15.3.2	Exit from Software Standby Mode.....	270
15.3.3	Clock Settling Time for Exit from Software Standby Mode.....	271
15.3.4	Sample Application of Software Standby Mode	272
15.3.5	Usage Note.....	272
15.4	Hardware Standby Mode	273
15.4.1	Transition to Hardware Standby Mode.....	273
15.4.2	Recovery from Hardware Standby Mode.....	273
15.4.3	Timing Relationships.....	274
Section 16	Electrical Specifications.....	275
16.1	Absolute Maximum Ratings	275
16.2	Electrical Characteristics	275
16.2.1	DC Characteristics	275
16.2.2	AC Characteristics	285
16.2.3	A/D Converter Characteristics.....	289
16.3	MCU Operational Timing.....	290
16.3.1	Bus Timing	290
16.3.2	Control Signal Timing	292
16.3.3	16-Bit Free-Running Timer Timing	294
16.3.4	8-Bit Timer Timing.....	295
16.3.5	Serial Communication Interface Timing	296
16.3.6	I/O Port Timing.....	297
16.3.7	External Clock Output Timing	297
Appendix A	CPU Instruction Set.....	299
A.1	Instruction Set List.....	299
A.2	Operation Code Map.....	307
A.3	Number of States Required for Execution.....	309
Appendix B	Register Field	315
B.1	Register Addresses and Bit Names.....	315
B.2	Register Descriptions.....	320
Appendix C	I/O Port Block Diagrams	352
C.1	Port 1 Block Diagram	352
C.2	Port 2 Block Diagram	353
C.3	Port 3 Block Diagram	354
C.4	Port 4 Block Diagrams.....	355
C.5	Port 5 Block Diagrams.....	360
C.6	Port 6 Block Diagrams.....	363
C.7	Port 7 Block Diagrams.....	370

Appendix D	Pin States	371
D.1	Port States in Each Mode.....	371
Appendix E	Timing of Transition to and Recovery from Hardware Standby Mode.....	373
Appendix F	Product Code Lineup	374
Appendix G	Package Dimensions	376

Section 1 Overview

1.1 Overview

The H8/3297 Series of single-chip microcomputers features an H8/300 CPU core and a complement of on-chip supporting modules implementing a variety of system functions.

The H8/300 CPU is a high-speed processor with an architecture featuring powerful bit-manipulation instructions, ideally suited for realtime control applications. The on-chip supporting modules implement peripheral functions needed in system configurations. These include ROM, RAM, three types of timers (a 16-bit free-running timer, 8-bit timers, and a watchdog timer), a serial communication interface (SCI), an A/D converter, and I/O ports.

The H8/3297 Series can operate in single-chip mode or in two expanded modes, depending on the requirements of the application.

The entire H8/3297 Series is available with mask ROM. The H8/3297 and H8/3294 are also available in ZTAT™ versions* that can be programmed at the user site.

Note: * ZTAT™ (zero turn-around time) is a trademark of Hitachi, Ltd.

Table 1-1 lists the features of the H8/3297 Series.

Table 1-1 Features

Item	Specification
CPU	<p>Two-way general register configuration</p> <ul style="list-style-type: none"> • Eight 16-bit registers, or • Sixteen 8-bit registers <p>High-speed operation</p> <ul style="list-style-type: none"> • Maximum clock rate (ϕ clock): 16 MHz at 5 V, 12 MHz at 4 V or 10 MHz at 3 V • 8- or 16-bit register-register add/subtract: 125 ns (16 MHz), 167 ns (12 MHz), 200 ns (10 MHz) • 8×8-bit multiply: 875 ns (16 MHz), 1167 ns (12 MHz), 1400 ns (10 MHz) • $16 \div 8$-bit divide: 875 ns (16 MHz), 1167 ns (12 MHz), 1400 ns (10 MHz) <p>Streamlined, concise instruction set</p> <ul style="list-style-type: none"> • Instruction length: 2 or 4 bytes • Register-register arithmetic and logic operations • MOV instruction for data transfer between registers and memory <p>Instruction set features</p> <ul style="list-style-type: none"> • Multiply instruction (8 bits \times 8 bits) • Divide instruction (16 bits \div 8 bits) • Bit-accumulator instructions • Register-indirect specification of bit positions
Memory	<ul style="list-style-type: none"> • H8/3297: 60k-byte ROM; 2k-byte RAM • H8/3296: 48k-byte ROM; 2k-byte RAM • H8/3294: 32k-byte ROM; 1k-byte RAM • H8/3292: 16k-byte ROM; 512-byte RAM
16-bit free-running timer (1 channel)	<ul style="list-style-type: none"> • One 16-bit free-running counter (can also count external events) • Two output-compare lines • Four input capture lines (can be buffered)
8-bit timer (2 channels)	<p>Each channel has</p> <ul style="list-style-type: none"> • One 8-bit up-counter (can also count external events) • Two time constant registers
Watchdog timer (WDT) (1 channel)	<ul style="list-style-type: none"> • Overflow can generate a reset or NMI interrupt • Also usable as interval timer
Serial communication interface (SCI) (1 channel)	<ul style="list-style-type: none"> • Asynchronous or synchronous mode (selectable) • Full duplex: can transmit and receive simultaneously • On-chip baud rate generator
A/D converter	<ul style="list-style-type: none"> • 10-bit resolution • Eight channels: single or scan mode (selectable) • Start of A/D conversion can be externally triggered • Sample-and-hold function
I/O ports	<ul style="list-style-type: none"> • 43 input/output lines (16 of which can drive LEDs) • 8 input-only lines

Table 1-1 Features (cont)

Item	Specification
Interrupts	<ul style="list-style-type: none">• Four external interrupt lines: $\overline{\text{NMI}}$, $\overline{\text{IRQ}}_0$ to $\overline{\text{IRQ}}_2$• 19 on-chip interrupt sources
Wait control	<ul style="list-style-type: none">• Three selectable wait modes
Operating modes	<ul style="list-style-type: none">• Expanded mode with on-chip ROM disabled (mode 1)• Expanded mode with on-chip ROM enabled (mode 2)• Single-chip mode (mode 3)
Power-down modes	<ul style="list-style-type: none">• Sleep mode• Software standby mode• Hardware standby mode
Other features	<ul style="list-style-type: none">• On-chip oscillator

Table 1-1 Features (cont)

Item	Specification	Part Number		Package	ROM
		5-V Version (16 MHz) 4-V Version (12 MHz)	3-V Version (10 MHz)		
Series lineup	H8/3297 ZTAT	HD6473297C16	HD6473297C16	64-pin windowed shrink DIP (DC-64S)	PROM
		HD6473297P16	HD6473297P16	64-pin shrink DIP (DP-64S)	
		HD6473297F16	HD6473297F16	64-pin QFP (FP-64A)	
		HD6473297TF16	HD6473297TF16	80-pin TQFP (TFP-80C)	
H8/3297	H8/3297	HD6433297P16	HD6433297VP10	64-pin shrink DIP (DP-64S)	Mask ROM
		HD6433297P12			
		HD6433297F16	HD6433297VF10	64-pin QFP (FP-64A)	
		HD6433297F12			
H8/3296	H8/3296	HD6433297TF16	HD6433297VTF10	80-pin TQFP (TFP-80C)	Mask ROM
		HD6433297TF12			
		HD6433296P16	HD6433296VP10	64-pin shrink DIP (DP-64S)	
		HD6433296P12			
H8/3294 ZTAT	H8/3294	HD6433296F16	HD6433296VF10	64-pin QFP (FP-64A)	Mask ROM
		HD6433296F12			
		HD6433296TF16	HD6433296VTF10	80-pin TQFP (TFP-80C)	
		HD6433296TF12			
H8/3294	H8/3294	HD6473294P16	HD6473294P16	64-pin shrink DIP (DP-64S)	PROM
		HD6473294F16	HD6473294F16	64-pin QFP (FP-64A)	
		HD6473294TF16	HD6473294TF16	80-pin TQFP (TFP-80C)	
H8/3294	H8/3294	HD6433294P16	HD6433294VP10	64-pin shrink DIP (DP-64S)	Mask ROM
		HD6433294P12			
		HD6433294F16	HD6433294VF10	64-pin QFP (FP-64A)	
H8/3292	H8/3292	HD6433294F12			Mask ROM
		HD6433294TF16	HD6433294VTF10	80-pin TQFP (TFP-80C)	
		HD6433294TF12			
H8/3292	H8/3292	HD6433292P16	HD6433292VP10	64-pin shrink DIP (DP-64S)	Mask ROM
		HD6433292P12			
		HD6433292F16	HD6433292VF10	64-pin QFP (FP-64A)	
H8/3292	H8/3292	HD6433292F12			Mask ROM
		HD6433292TF16	HD6433292VTF10	80-pin TQFP (TFP-80C)	
		HD6433292TF12			

1.2 Block Diagram

Figure 1-1 shows a block diagram of the H8/3297 Series.

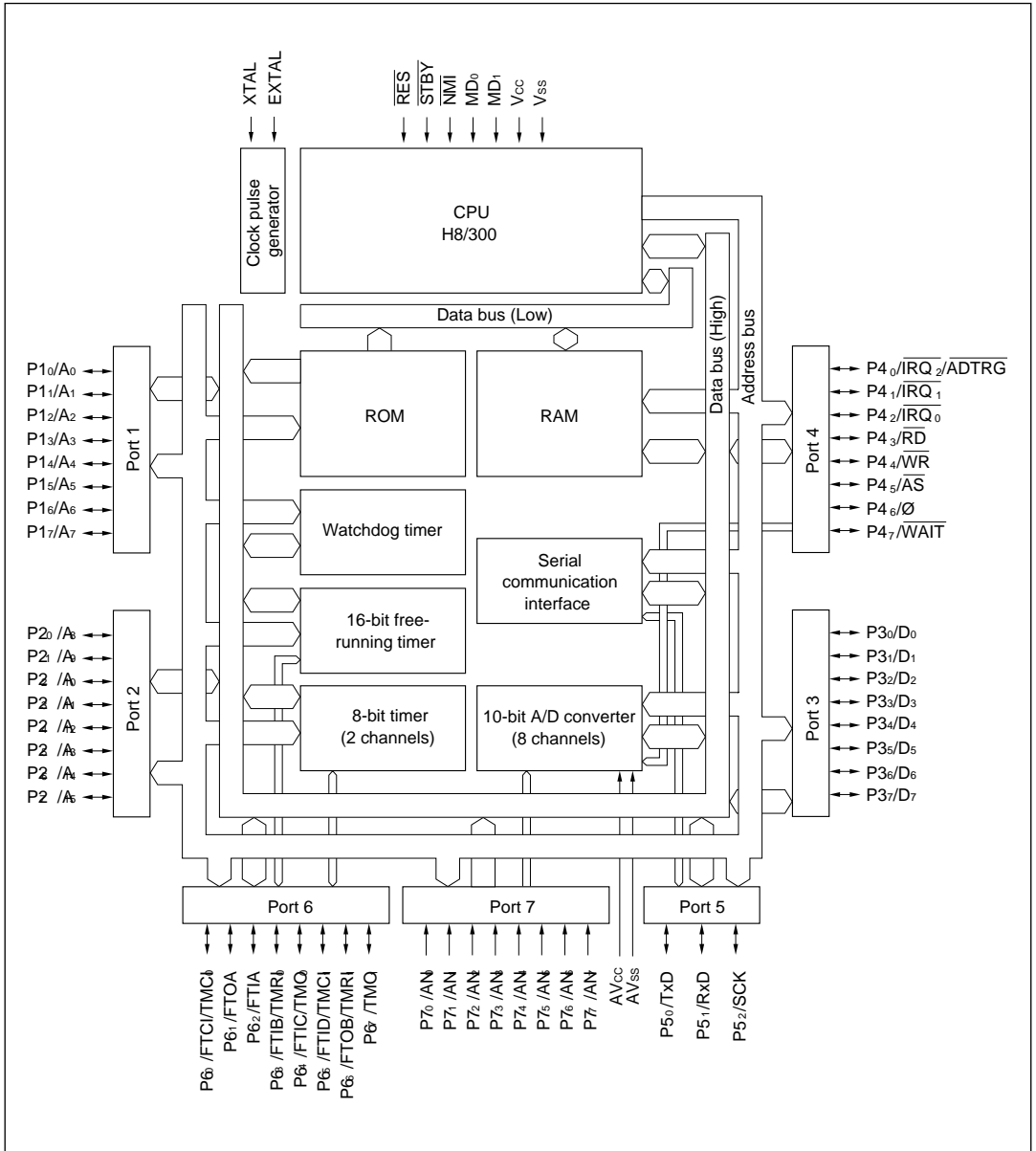

Figure 1-1 Block Diagram

1.3 Pin Assignments and Functions

1.3.1 Pin Arrangement

Figure 1-2 shows the pin arrangement of the DC-64S and DP-64S packages. Figure 1-3 shows the pin arrangement of the FP-64A package. Figure 1-4 shows the pin arrangement of the TFP-80C package.

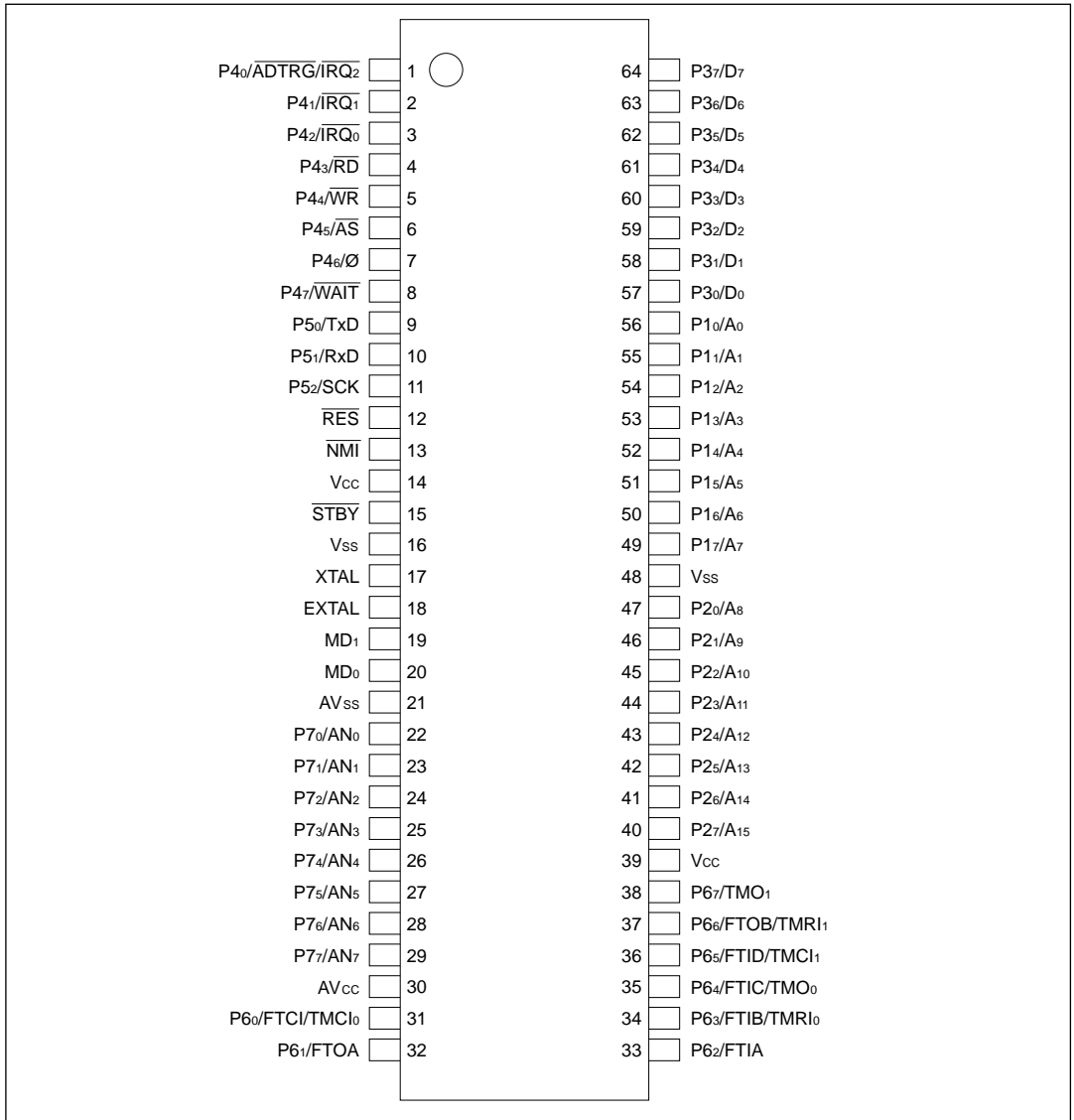

Figure 1-2 Pin Arrangement (DC-64S and DP-64S, Top view)

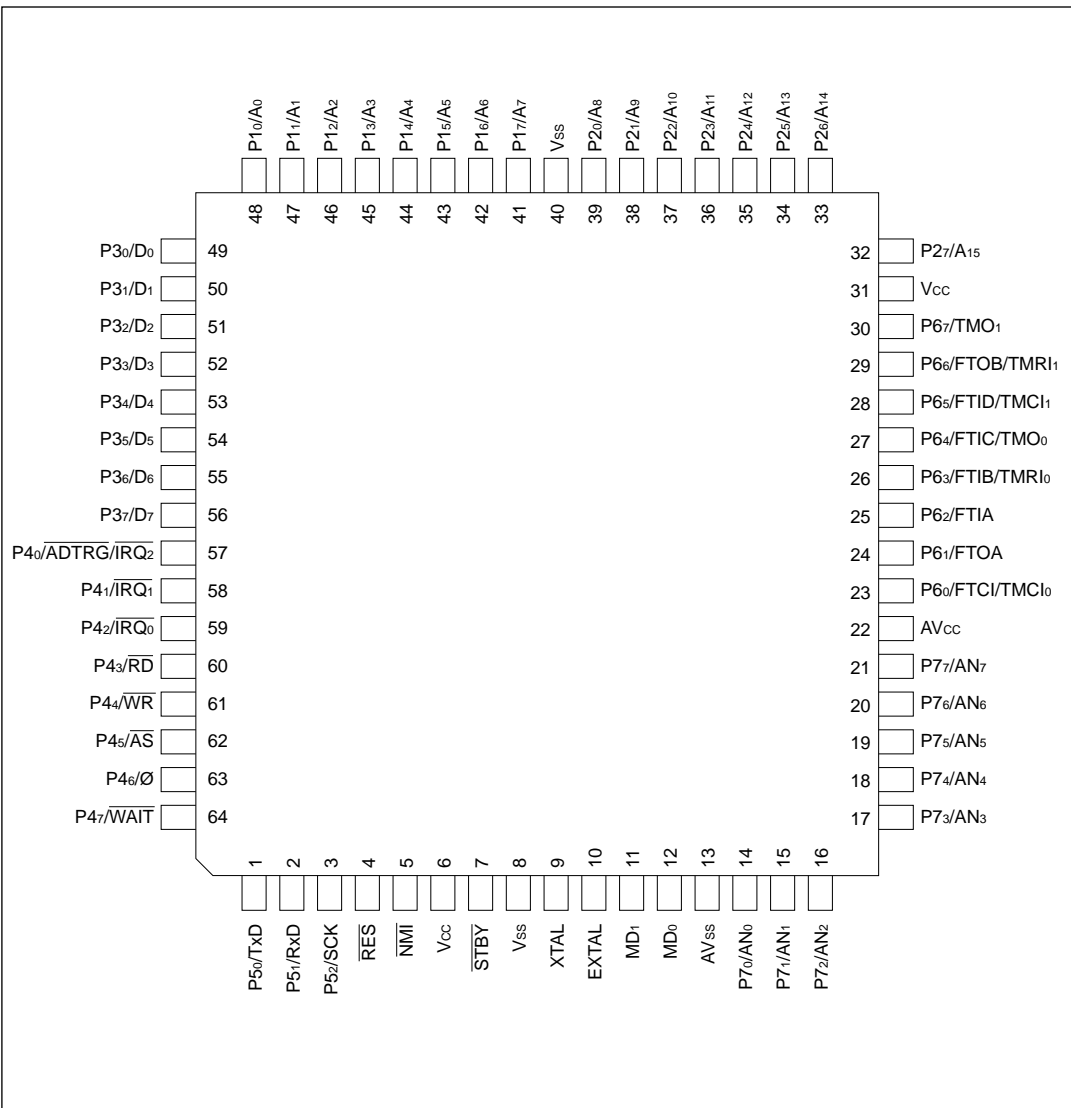

Figure 1-3 Pin Arrangement (FP-64A, Top view)

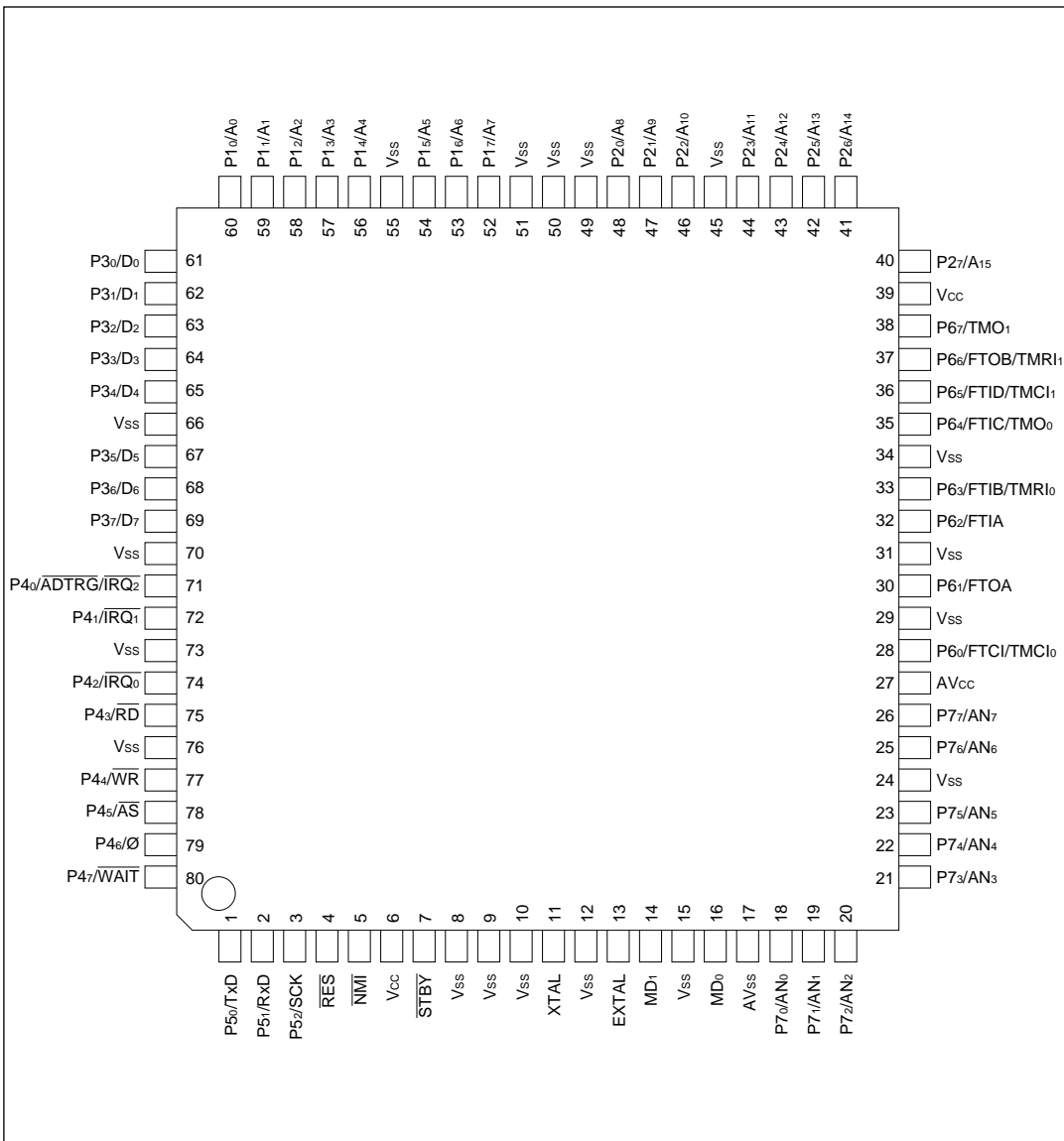

Figure 1-4 Pin Arrangement (TFP-80C, Top view)

1.3.2 Pin Functions

(1) **Pin Assignments in Each Operating Mode:** Table 1-2 lists the assignments of the pins of the DC-64S, DP-64S, FP-64A, and TFP-80C packages in each operating mode.

Table 1-2 Pin Assignments in Each Operating Mode

Pin No.			Expanded modes		Single-chip mode	PROM	
DC-64S	DP-64S	FP-64A	TFP-80C	Mode 1	Mode 2	Mode 3	mode
1	57	71		$P4_0/\overline{IRQ_2}/ADTRG$	$P4_0/\overline{IRQ_2}/ADTRG$	$P4_0/\overline{IRQ_2}/ADTRG$	EA ₁₆
2	58	72		$P4_1/\overline{IRQ_1}$	$P4_1/\overline{IRQ_1}$	$P4_1/\overline{IRQ_1}$	EA ₁₅
—	—	73		V _{SS}	V _{SS}	V _{SS}	V _{SS}
3	59	74		$P4_2/\overline{IRQ_0}$	$P4_2/\overline{IRQ_0}$	$P4_2/\overline{IRQ_0}$	PGM
4	60	75		\overline{RD}	\overline{RD}	P4 ₃	NC
—	—	76		V _{SS}	V _{SS}	V _{SS}	V _{SS}
5	61	77		\overline{WR}	\overline{WR}	P4 ₄	NC
6	62	78		\overline{AS}	\overline{AS}	P4 ₅	NC
7	63	79		∅	∅	P4 ₆ /∅	NC
8	64	80		$P4_7/\overline{WAIT}$	$P4_7/\overline{WAIT}$	P4 ₇	NC
9	1	1		P5 ₀ /TxD	P5 ₀ /TxD	P5 ₀ /TxD	NC
10	2	2		P5 ₁ /RxD	P5 ₁ /RxD	P5 ₁ /RxD	NC
11	3	3		P5 ₂ /SCK	P5 ₂ /SCK	P5 ₂ /SCK	NC
12	4	4		\overline{RES}	\overline{RES}	\overline{RES}	V _{PP}
13	5	5		\overline{NMI}	\overline{NMI}	\overline{NMI}	EA ₉
14	6	6		V _{CC}	V _{CC}	V _{CC}	V _{CC}
15	7	7		\overline{STBY}	\overline{STBY}	\overline{STBY}	V _{SS}
16	8	8		V _{SS}	V _{SS}	V _{SS}	V _{SS}
—	—	9		V _{SS}	V _{SS}	V _{SS}	V _{SS}
—	—	10		V _{SS}	V _{SS}	V _{SS}	V _{SS}
17	9	11		XTAL	XTAL	XTAL	NC
—	—	12		V _{SS}	V _{SS}	V _{SS}	V _{SS}
18	10	13		EXTAL	EXTAL	EXTAL	NC
19	11	14		MD ₁	MD ₁	MD ₁	V _{SS}

Note: Pins marked NC should be left unconnected.
For details on PROM mode, refer to 14.2, PROM Mode.

Table 1-2 Pin Assignments in Each Operating Mode (cont)

Pin No.			Expanded modes		Single-chip mode	PROM
DC-64S			Mode 1	Mode 2	Mode 3	mode
DP-64S	FP-64A	TFP-80C				
—	—	15	V _{SS}	V _{SS}	V _{SS}	V _{SS}
20	12	16	MD ₀	MD ₀	MD ₀	V _{SS}
21	13	17	AV _{SS}	AV _{SS}	AV _{SS}	V _{SS}
22	14	18	P7 ₀ /AN ₀	P7 ₀ /AN ₀	P7 ₀ /AN ₀	NC
23	15	19	P7 ₁ /AN ₁	P7 ₁ /AN ₁	P7 ₁ /AN ₁	NC
24	16	20	P7 ₂ /AN ₂	P7 ₂ /AN ₂	P7 ₂ /AN ₂	NC
25	17	21	P7 ₃ /AN ₃	P7 ₃ /AN ₃	P7 ₃ /AN ₃	NC
26	18	22	P7 ₄ /AN ₄	P7 ₄ /AN ₄	P7 ₄ /AN ₄	NC
27	19	23	P7 ₅ /AN ₅	P7 ₅ /AN ₅	P7 ₅ /AN ₅	NC
—	—	24	V _{SS}	V _{SS}	V _{SS}	V _{SS}
28	20	25	P7 ₆ /AN ₆	P7 ₆ /AN ₆	P7 ₆ /AN ₆	NC
29	21	26	P7 ₇ /AN ₇	P7 ₇ /AN ₇	P7 ₇ /AN ₇	NC
30	22	27	AV _{CC}	AV _{CC}	AV _{CC}	V _{CC}
31	23	28	P6 ₀ /FTCI/TMCI ₀	P6 ₀ /FTCI/TMCI ₀	P6 ₀ /FTCI/TMCI ₀	NC
—	—	29	V _{SS}	V _{SS}	V _{SS}	V _{SS}
32	24	30	P6 ₁ /FTOA	P6 ₁ /FTOA	P6 ₁ /FTOA	NC
—	—	31	V _{SS}	V _{SS}	V _{SS}	V _{SS}
33	25	32	P6 ₂ /FTIA	P6 ₂ /FTIA	P6 ₂ /FTIA	NC
34	26	33	P6 ₃ /FTIB/TMRI ₀	P6 ₃ /FTIB/TMRI ₀	P6 ₃ /FTIB/TMRI ₀	V _{CC}
—	—	34	V _{SS}	V _{SS}	V _{SS}	V _{SS}
35	27	35	P6 ₄ /FTIC/TMO ₀	P6 ₄ /FTIC/TMO ₀	P6 ₄ /FTIC/TMO ₀	V _{CC}
36	28	36	P6 ₅ /FTID/TMCI ₁	P6 ₅ /FTID/TMCI ₁	P6 ₅ /FTID/TMCI ₁	NC
37	29	37	P6 ₆ /FTOB/TMRI ₁	P6 ₆ /FTOB/TMRI ₁	P6 ₆ /FTOB/TMRI ₁	NC
38	30	38	P6 ₇ /TMO ₁	P6 ₇ /TMO ₁	P6 ₇ /TMO ₁	NC
39	31	39	V _{CC}	V _{CC}	V _{CC}	V _{CC}
40	32	40	A ₁₅	A ₂₇ /A ₁₅	P ₂₇	\overline{CE}
41	33	41	A ₁₄	P ₂₆ /A ₁₄	P ₂₆	EA ₁₄
42	34	42	A ₁₃	P ₂₅ /A ₁₃	P ₂₅	EA ₁₃

Note: Pins marked NC should be left unconnected.

For details on PROM mode, refer to 14.2, PROM Mode.

Table 1-2 Pin Assignments in Each Operating Mode (cont)

Pin No.			Expanded modes		Single-chip mode	PROM
DC-64S			Mode 1	Mode 2	Mode 3	mode
43	35	43	A ₁₂	P2 ₄ /A ₁₂	P2 ₄	EA ₁₂
44	36	44	A ₁₁	P2 ₃ /A ₁₁	P2 ₃	EA ₁₁
—	—	45	V _{SS}	V _{SS}	V _{SS}	V _{SS}
45	37	46	A ₁₀	P2 ₂ /A ₁₀	P2 ₂	EA ₁₀
46	38	47	A ₉	P2 ₁ /A ₉	P2 ₁	\overline{OE}
47	39	48	A ₈	P2 ₀ /A ₈	P2 ₀	EA ₈
—	—	49	V _{SS}	V _{SS}	V _{SS}	V _{SS}
48	40	50	V _{SS}	V _{SS}	V _{SS}	V _{SS}
—	—	51	V _{SS}	V _{SS}	V _{SS}	V _{SS}
49	41	52	A ₇	P1 ₇ /A ₇	P1 ₇	EA ₇
50	42	53	A ₆	P1 ₆ /A ₆	P1 ₆	EA ₆
51	43	54	A ₅	P1 ₅ /A ₅	P1 ₅	EA ₅
—	—	55	V _{SS}	V _{SS}	V _{SS}	V _{SS}
52	44	56	A ₄	P1 ₄ /A ₄	P1 ₄	EA ₄
53	45	57	A ₃	P1 ₃ /A ₃	P1 ₃	EA ₃
54	46	58	A ₂	P1 ₂ /A ₂	P1 ₂	EA ₂
55	47	59	A ₁	P1 ₁ /A ₁	P1 ₁	EA ₁
56	48	60	A ₀	P1 ₀ /A ₀	P1 ₀	EA ₀
57	49	61	D ₀	D ₀	P3 ₀	EO ₀
58	50	62	D ₁	D ₁	P3 ₁	EO ₁
59	51	63	D ₂	D ₂	P3 ₂	EO ₂
60	52	64	D ₃	D ₃	P3 ₃	EO ₃
61	53	65	D ₄	D ₄	P3 ₄	EO ₄
—	—	66	V _{SS}	V _{SS}	V _{SS}	V _{SS}
62	54	67	D ₅	D ₅	P3 ₅	EO ₅
63	55	68	D ₆	D ₆	P3 ₆	EO ₆
64	56	69	D ₇	D ₇	P3 ₇	EO ₇
—	—	70	V _{SS}	V _{SS}	V _{SS}	V _{SS}

Note: Pins marked NC should be left unconnected.
 For details on PROM mode, refer to 14.2, PROM Mode.

(2) **Pin Functions:** Table 1-3 gives a concise description of the function of each pin.

Table 1-3 Pin Functions

Type	Symbol	Pin No.			I/O	Name and function
		DC-64S DP-64S	FP-64A	TFP-80C		
Power	V_{CC}	14, 39	6, 31	6, 39	I	Power: Connected to the power supply (+5 V or +3 V). Connect both V_{CC} pins to the system power supply (+5 V or +3 V).
	V_{SS}	16, 48	8, 40	8, 9, 10, 12, 15, 24, 29, 31, 34, 45, 49, 50, 51, 55, 66, 70, 73, 76	I	Ground: Connected to ground (0 V). Connect all V_{SS} pins to system ground (0 V).
Clock	XTAL	17	9	11	I	Crystal: Connected to a crystal oscillator. The crystal frequency should be the same as the desired system clock frequency. If an external clock is input at the EXTAL pin, a reverse-phase clock should be input at the XTAL pin.
	EXTAL	18	10	13	I	External crystal: Connected to a crystal oscillator or external clock. The frequency of the external clock should be the same as the desired system clock frequency. See section 6.2, Oscillator Circuit for examples of connections to a crystal and external clock.
	\emptyset	7	63	79	O	System clock: Supplies the system clock to peripheral devices.
System control	\overline{RES}	12	4	4	I	Reset: A Low input causes the chip to reset.
	\overline{STBY}	15	7	7	I	Standby: A transition to the hardware standby mode (a power-down state) occurs when a Low input is received at the \overline{STBY} pin.
Address bus	A_{15} to A_0	40 to 47, 49 to 56	32 to 39, 41 to 48	40 to 44, 46 to 48, 52 to 54, 56 to 60	O	Address bus: Address output pins.

Table 1-3 Pin Functions (cont)

Type	Symbol	Pin No.			I/O	Name and function
		DC-64S DP-64S	FP-64A	TFP-80C		
Data bus	D ₇ to D ₀	64 to 57	56 to 49	65 to 61, 69 to 67	I/O	Data bus: 8-Bit bidirectional data bus.
Bus control	$\overline{\text{WAIT}}$	8	64	80	I	Wait: Requests the CPU to insert wait states into the bus cycle when an external address is accessed.
	$\overline{\text{RD}}$	4	60	75	O	Read: Goes Low to indicate that the CPU is reading an external address.
	$\overline{\text{WR}}$	5	61	77	O	Write: Goes Low to indicate that the CPU is writing to an external address.
	$\overline{\text{AS}}$	6	62	78	O	Address strobe: Goes Low to indicate that there is a valid address on the address bus.
Interrupt signals	$\overline{\text{NMI}}$	13	5	5	I	Nonmaskable interrupt: Highest-priority interrupt request. The NMIEG bit in the system control register (SYSCR) determines whether the interrupt is recognized at the rising or falling edge of the NMI input.
	$\overline{\text{IRQ}}_0$ to $\overline{\text{IRQ}}_2$	1 to 3	57 to 59	71, 72, 74	I	Interrupt request 0 to 2: Maskable interrupt request pins.
Operating mode control	MD ₁ , MD ₀	19, 20	11, 12	14, 16	I	Mode: Input pins for setting the MCU operating mode according to the table below.
						MD₁ MD₀ Mode Description
					0 1	Mode 1 Expanded mode with on-chip ROM disabled
					1 0	Mode 2 Expanded mode with on-chip ROM enabled
				1 1	Mode 3 Single-chip mode	

Table 1-3 Pin Functions (cont)

Type	Symbol	Pin No.			I/O	Name and function
		DC-64S DP-64S	FP-64A	TFP-80C		
16-bit free-running timer (FRT)	FTOA, FTOB	32, 37	24, 29	30, 37	O	FRT output compare A and B: Output pins controlled by comparators A and B of the free-running timer.
	FTCI	31	23	28	I	FRT counter clock input: Input pin for an external clock signal for the free-running timer.
	FTIA to FTID	33 to 36	25 to 28	32, 33, 35, 36	I	FRT input capture A to D: Input capture pins for the free-running timer.
8-bit timer	TMO ₀ , TMO ₁	35, 38	27, 30	35, 38	O	8-bit timer output (channels 0 and 1): Compare-match output pins for the 8-bit timers.
	TMCI ₀ , TMCI ₁	31, 36	23, 28	28, 36	I	8-bit timer counter clock input (channels 0 and 1): External clock input pins for the 8-bit timer counters.
	TMRI ₀ , TMRI ₁	34, 37	26, 29	33, 37	I	8-bit timer counter reset input (channels 0 and 1): A High input at these pins resets the 8-bit timer counters.
Serial communication interface (SCI)	TxD	9	1	1	O	Transmit data: Data output pin for the serial communication interface.
	RxD	10	2	2	I	Receive data: Data input pin for the serial communication interface.
	SCK	11	3	3	I/O	Serial clock: Input/output pin for the serial clock.
A/D converter	AN ₇ to AN ₀	29 to 22	21 to 14	26, 25, 23 to 18	I	Analog input: Analog signal input pins for the A/D converter.
	ADTRG	1	57	71	I	A/D trigger: External trigger input for starting the A/D converter.
	AV _{CC}	30	22	27	I	Programmable Wait Mode: The number of wait states (T_W) selected by bits WC1 and WC0 are inserted in all accesses to external addresses, regardless of the $\overline{\text{WAIT}}$ pin state.
	AV _{SS}	21	13	17	I	Analog ground: Ground pin for the A/D converter. Connect to system ground.

Table 1-3 Pin Functions (cont)

Type	Symbol	Pin No.			I/O	Name and function
		DC-64S DP-64S	FP-64A	TFP-80C		
General-purpose I/O	P1 ₇ to P1 ₀	49 to 56	41 to 48	52 to 54, 56 to 60	I/O	Port 1: An 8-bit input/output port with programmable MOS input pull-ups and LED driving capability. The direction of each bit can be selected in the port 1 data direction register (P1DDR).
	P2 ₇ to P2 ₀	40 to 47	32 to 39	40 to 44, 46 to 48	I/O	Port 2: An 8-bit input/output port with programmable MOS input pull-ups and LED driving capability. The direction of each bit can be selected in the port 2 data direction register (P2DDR).
	P3 ₇ to P3 ₀	64 to 57	56 to 49	69 to 67, 65 to 61	I/O	Port 3: An 8-bit input/output port with programmable MOS input pull-ups. The direction of each bit can be selected in the port 3 data direction register (P3DDR).
	P4 ₇ to P4 ₀	8 to 1	64 to 57	80 to 77, 75, 74, 72, 71	I/O	Port 4: An 8-bit input/output port. The direction of each bit can be selected in the port 4 data direction register (P4DDR).
	P5 ₂ to P5 ₀	11 to 9	3 to 1	3 to 1	I/O	Port 5: A 3-bit input/output port. The direction of each bit can be selected in the port 5 data direction register (P5DDR).
	P6 ₇ to P6 ₀	38 to 31	30 to 23	38 to 35, 33, 32, 30, 28	I/O	Port 6: An 8-bit input/output port. The direction of each bit can be selected in the port 6 data direction register (P6DDR).
	P7 ₇ to P7 ₀	29 to 22	21 to 14	26, 25, 23 to 18	I	Port 7: An 8-bit input port.

Section 2 CPU

2.1 Overview

The H8/300 CPU is a fast central processing unit with eight 16-bit general registers (also configurable as 16 eight-bit registers) and a concise instruction set designed for high-speed operation.

2.1.1 Features

The main features of the H8/300 CPU are listed below.

- Two-way register configuration
 - Sixteen 8-bit general registers, or
 - Eight 16-bit general registers
- Instruction set with 57 basic instructions, including:
 - Multiply and divide instructions
 - Powerful bit-manipulation instructions
- Eight addressing modes
 - Register direct (Rn)
 - Register indirect (@Rn)
 - Register indirect with displacement (@(d:16, Rn))
 - Register indirect with post-increment or pre-decrement (@Rn+ or @-Rn)
 - Absolute address (@aa:8 or @aa:16)
 - Immediate (#xx:8 or #xx:16)
 - PC-relative (@(d:8, PC))
 - Memory indirect (@@aa:8)
- Maximum 64-kbyte address space
- High-speed operation
 - All frequently-used instructions are executed in two to four states
- Maximum clock rate (\emptyset clock): 16 MHz at 5 V, 12 MHz at 4 V or 10 MHz at 3 V
 - 8- or 16-bit register-register add or subtract: 125 ns (16 MHz), 167 ns (12 MHz), 200 ns (10 MHz)
 - 8×8 -bit multiply: 875 ns (16 MHz), 1167 ns (12 MHz), 1400 ns (10 MHz)
 - $16 \div 8$ -bit divide: 875 ns (16 MHz), 1167 ns (12 MHz), 1400 ns (10 MHz)
- Power-down mode
 - SLEEP instruction

2.1.2 Address Space

The H8/300 CPU supports an address space with a maximum size of 64 kbytes for program code and data combined. The memory map differs depending on the mode (mode 1, 2, or 3). For details, see section 3.4, Address Space Map in Each Operating Mode.

2.1.3 Register Configuration

Figure 2-1 shows the internal register structure of the H8/300 CPU. There are two groups of registers: the general registers and control registers.

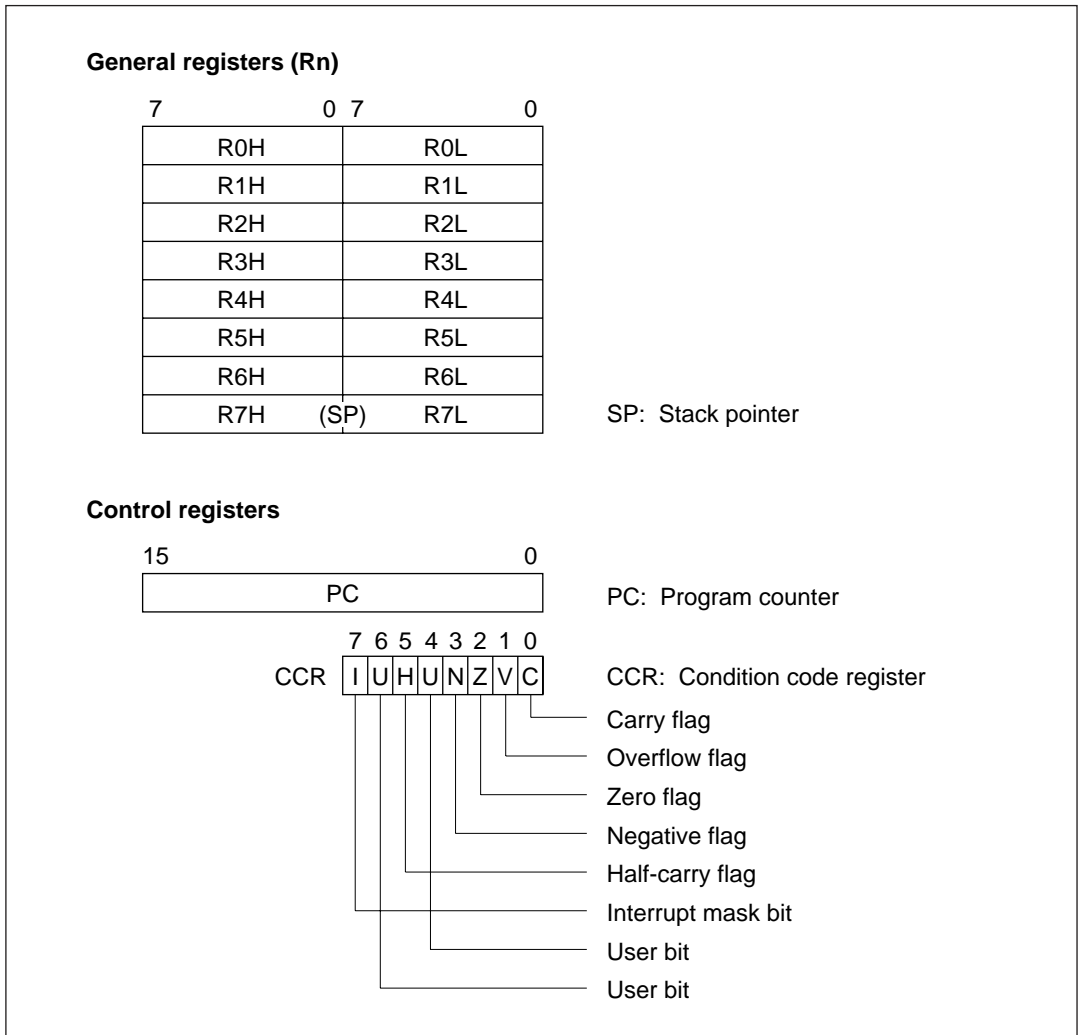

Figure 2-1 CPU Registers

2.2 Register Descriptions

2.2.1 General Registers

All the general registers can be used as both data registers and address registers. When used as address registers, the general registers are accessed as 16-bit registers (R0 to R7). When used as data registers, they can be accessed as 16-bit registers, or the high and low bytes can be accessed separately as 8-bit registers (R0H to R7H and R0L to R7L).

R7 also functions as the stack pointer, used implicitly by hardware in processing interrupts and subroutine calls. In assembly-language coding, R7 can also be denoted by the letters SP. As indicated in figure 2-2, R7 (SP) points to the top of the stack.

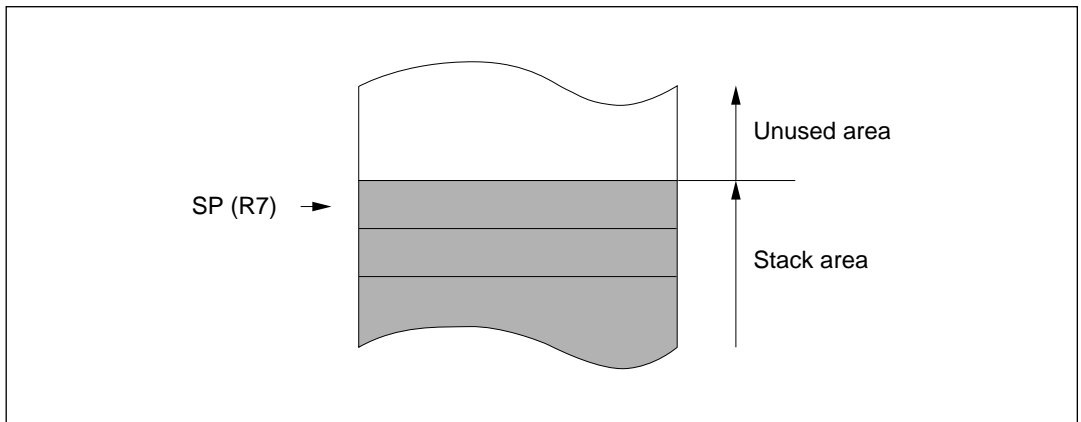

Figure 2-2 Stack Pointer

2.2.2 Control Registers

The CPU control registers include a 16-bit program counter (PC) and an 8-bit condition code register (CCR).

(1) Program Counter (PC): This 16-bit register indicates the address of the next instruction the CPU will execute. Each instruction is accessed in 16 bits (1 word), so the least significant bit of the PC is ignored (always regarded as 0).

(2) Condition Code Register (CCR): This 8-bit register contains internal status information, including carry (C), overflow (V), zero (Z), negative (N), and half-carry (H) flags and the interrupt mask bit (I).

Bit 7—Interrupt Mask Bit (I): When this bit is set to 1, all interrupts except NMI are masked. This bit is set to 1 automatically by a reset and at the start of interrupt handling.

Bit 6—User Bit (U): This bit can be written and read by software (using the LDC, STC, ANDC, ORC, and XORC instructions).

Bit 5—Half-Carry Flag (H): This flag is set to 1 when the ADD.B, ADDX.B, SUB.B, SUBX.B, NEG.B, or CMP.B instruction causes a carry or borrow out of bit 3, and is cleared to 0 otherwise. Similarly, it is set to 1 when the ADD.W, SUB.W, or CMP.W instruction causes a carry or borrow out of bit 11, and cleared to 0 otherwise. It is used implicitly in the DAA and DAS instructions.

Bit 4—User Bit (U): This bit can be written and read by software (using the LDC, STC, ANDC, ORC, and XORC instructions).

Bit 3—Negative Flag (N): This flag indicates the most significant bit (sign bit) of the result of an instruction.

Bit 2—Zero Flag (Z): This flag is set to 1 to indicate a zero result and cleared to 0 to indicate a nonzero result.

Bit 1—Overflow Flag (V): This flag is set to 1 when an arithmetic overflow occurs, and cleared to 0 at other times.

Bit 0—Carry Flag (C): This flag is used by:

- Add and subtract instructions, to indicate a carry or borrow at the most significant bit of the result
- Shift and rotate instructions, to store the value shifted out of the most significant or least significant bit
- Bit manipulation and bit load instructions, as a bit accumulator

The LDC, STC, ANDC, ORC, and XORC instructions enable the CPU to load and store the CCR, and to set or clear selected bits by logic operations. The N, Z, V, and C flags are used in conditional branching instructions (B_{CC}).

For the action of each instruction on the flag bits, see the *H8/300 Series Programming Manual*.

2.2.3 Initial Register Values

When the CPU is reset, the program counter (PC) is loaded from the vector table and the interrupt mask bit (I) in the CCR is set to 1. The other CCR bits and the general registers are not initialized. In particular, the stack pointer (R7) is not initialized. The stack pointer and CCR should be initialized by software, by the first instruction executed after a reset.

2.3 Data Formats

The H8/300 CPU can process 1-bit data, 4-bit (BCD) data, 8-bit (byte) data, and 16-bit (word) data.

- Bit manipulation instructions operate on 1-bit data specified as bit n ($n = 0, 1, 2, \dots, 7$) in a byte operand.
- All arithmetic and logic instructions except ADDS and SUBS can operate on byte data.
- The DAA and DAS instruction perform decimal arithmetic adjustments on byte data in packed BCD form. Each nibble of the byte is treated as a decimal digit.
- The MOV.W, ADD.W, SUB.W, CMP.W, ADDS, SUBS, MULXU ($8 \text{ bits} \times 8 \text{ bits}$), and DIVXU ($16 \text{ bits} \div 8 \text{ bits}$) instructions operate on word data.

2.3.1 Data Formats in General Registers

Data of all the sizes above can be stored in general registers as shown in figure 2-3.

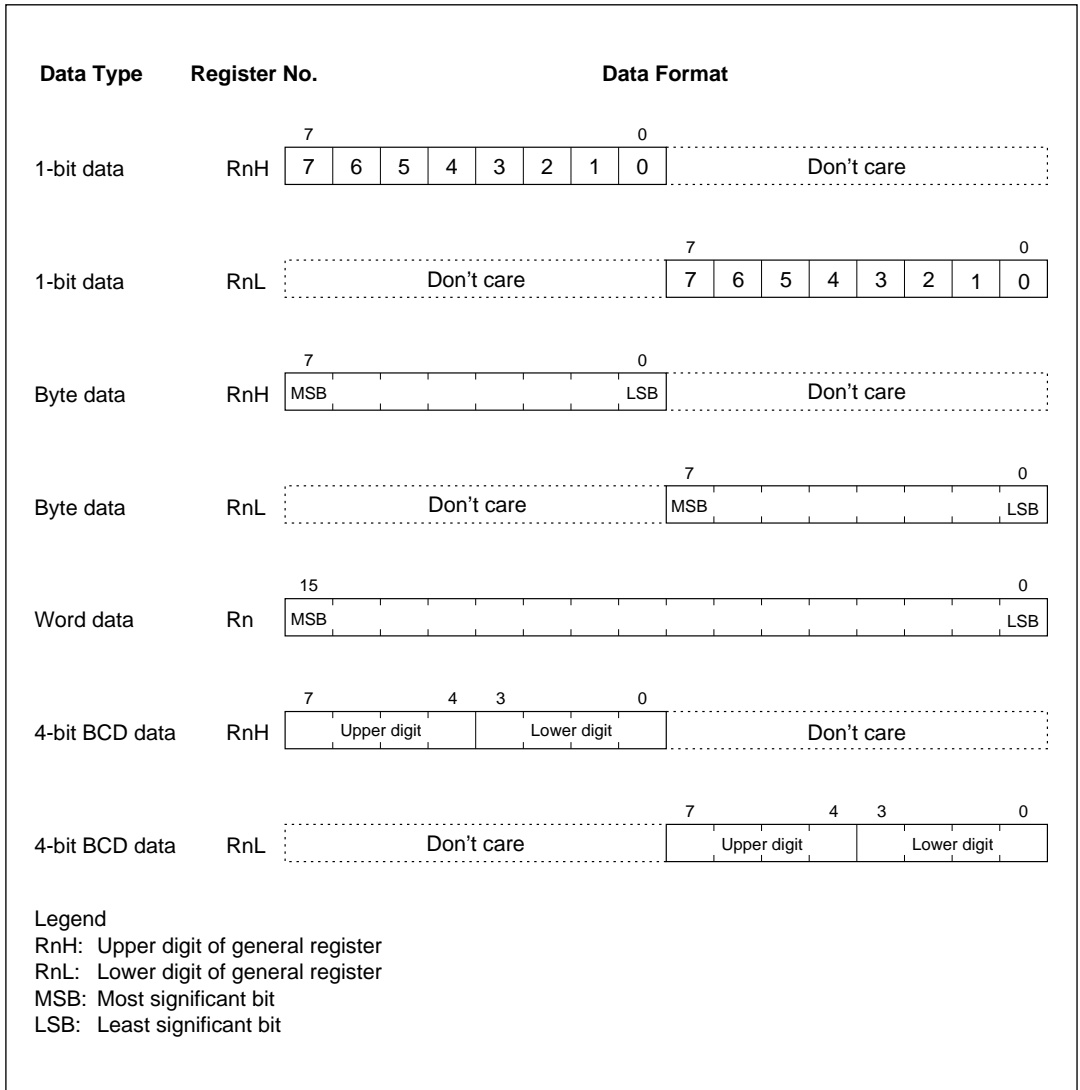

Figure 2-3 Register Data Formats

2.3.2 Memory Data Formats

Figure 2-4 indicates the data formats in memory.

Word data stored in memory must always begin at an even address. In word access the least significant bit of the address is regarded as 0. If an odd address is specified, no address error occurs but the access is performed at the preceding even address. This rule affects MOV.W instructions and branching instructions, and implies that only even addresses should be stored in the vector table.

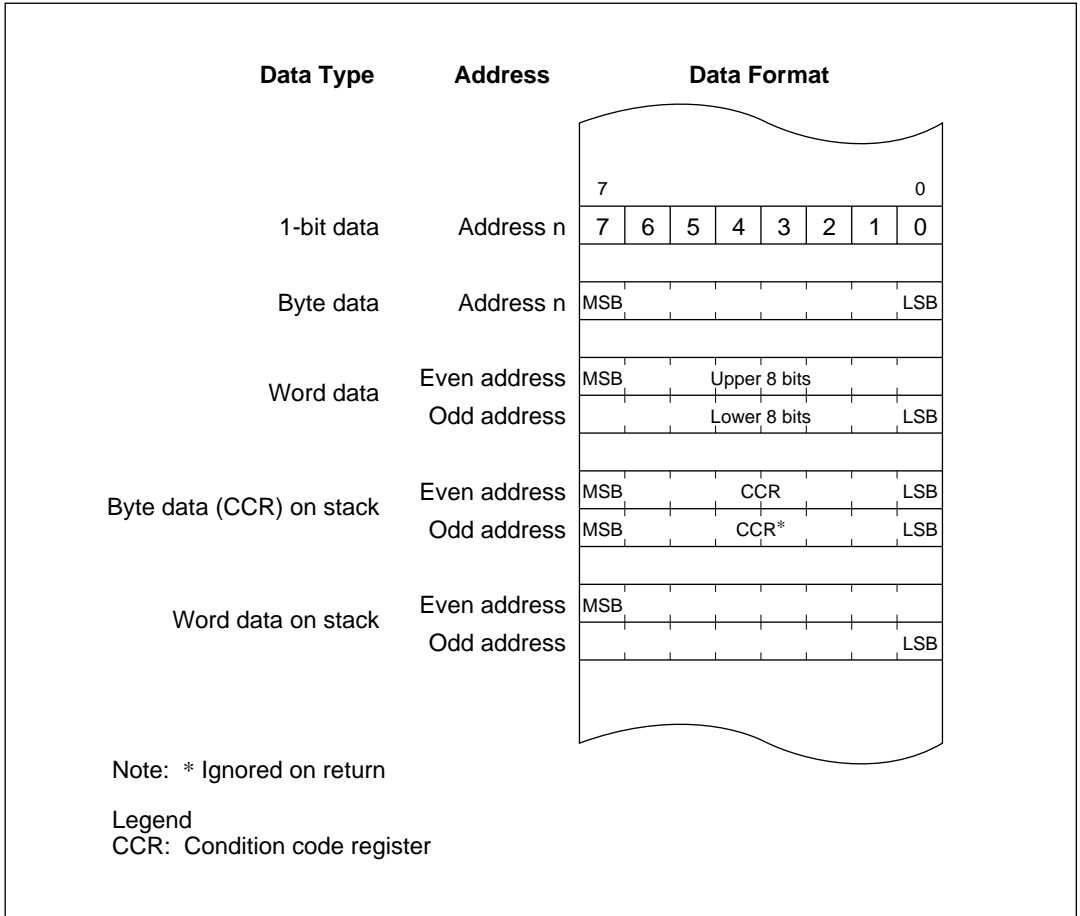

Figure 2-4 Memory Data Formats

When the stack is addressed by register R7, it must always be accessed a word at a time. When the CCR is pushed on the stack, two identical copies of the CCR are pushed to make a complete word. When they are restored, the lower byte is ignored.

2.4 Addressing Modes

2.4.1 Addressing Mode

The H8/300 CPU supports eight addressing modes. Each instruction uses a subset of these addressing modes.

Table 2-1 Addressing Modes

No.	Addressing Mode	Symbol
(1)	Register direct	Rn
(2)	Register indirect	@Rn
(3)	Register indirect with displacement	@(d:16, Rn)
(4)	Register indirect with post-increment Register indirect with pre-decrement	@Rn+ @-Rn
(5)	Absolute address	@aa:8 or @aa:16
(6)	Immediate	#xx:8 or #xx:16
(7)	Program-counter-relative	@(d:8, PC)
(8)	Memory indirect	@@aa:8

(1) Register Direct—Rn: The register field of the instruction specifies an 8- or 16-bit general register containing the operand. In most cases the general register is accessed as an 8-bit register. Only the MOV.W, ADD.W, SUB.W, CMP.W, ADDS, SUBS, MULXU (8 bits × 8 bits), and DIVXU (16 bits ÷ 8 bits) instructions have 16-bit operands.

(2) Register Indirect—@Rn: The register field of the instruction specifies a 16-bit general register containing the address of the operand.

(3) Register Indirect with Displacement—@(d:16, Rn): This mode, which is used only in MOV instructions, is similar to register indirect but the instruction has a second word (bytes 3 and 4) which is added to the contents of the specified general register to obtain the operand address. For the MOV.W instruction, the resulting address must be even.

(4) Register Indirect with Post-Increment or Pre-Decrement—@Rn+ or @-Rn:

- Register indirect with Post-Increment—@Rn+

The @Rn+ mode is used with MOV instructions that load registers from memory.

It is similar to the register indirect mode, but the 16-bit general register specified in the register field of the instruction is incremented after the operand is accessed. The size of the increment is 1 or 2 depending on the size of the operand: 1 for MOV.B; 2 for MOV.W. For MOV.W, the original contents of the 16-bit general register must be even.

- Register Indirect with Pre-Decrement—@-Rn

The @-Rn mode is used with MOV instructions that store register contents to memory.

It is similar to the register indirect mode, but the 16-bit general register specified in the register field of the instruction is decremented before the operand is accessed. The size of the decrement is 1 or 2 depending on the size of the operand: 1 for MOV.B; 2 for MOV.W. For MOV.W, the original contents of the 16-bit general register must be even.

(5) Absolute Address—@aa:8 or @aa:16: The instruction specifies the absolute address of the operand in memory. The MOV.B instruction uses an 8-bit absolute address of the form H'FFxx. The upper 8 bits are assumed to be 1, so the possible address range is H'FF00 to H'FFFF (65280 to 65535). The MOV.B, MOV.W, JMP, and JSR instructions can use 16-bit absolute addresses.

(6) Immediate—#xx:8 or #xx:16: The instruction contains an 8-bit operand in its second byte, or a 16-bit operand in its third and fourth bytes. Only MOV.W instructions can contain 16-bit immediate values.

The ADDS and SUBS instructions implicitly contain the value 1 or 2 as immediate data. Some bit manipulation instructions contain 3-bit immediate data (#xx:3) in the second or fourth byte of the instruction, specifying a bit number.

(7) Program-Counter-Relative—@(d:8, PC): This mode is used to generate branch addresses in the Bcc and BSR instructions. An 8-bit value in byte 2 of the instruction code is added as a sign-extended value to the program counter contents. The result must be an even number. The possible branching range is -126 to +128 bytes (-63 to +64 words) from the current address.

(8) Memory Indirect—@@aa:8: This mode can be used by the JMP and JSR instructions. The second byte of the instruction code specifies an 8-bit absolute address from H'0000 to H'00FF (0 to 255). The word located at this address contains the branch address. The upper 8 bits of the absolute address are 0 (H'00), thus the branch address is limited to values from 0 to 255 (H'0000 to H'00FF). Note that some of the addresses in this range are also used in the vector table. Refer to section 3.4, Address Space Map in Each Operating Mode.

If an odd address is specified as a branch destination or as the operand address of a MOV.W instruction, the least significant bit is regarded as 0, causing word access to be performed at the address preceding the specified address. See section 2.3.2, Memory Data Formats, for further information.

2.4.2 Calculation of Effective Address

Table 2-2 shows how the H8/300 calculates effective addresses in each addressing mode.

Arithmetic, logic, and shift instructions use register direct addressing (1). The ADD.B, ADDX.B, SUBX.B, CMP.B, AND.B, OR.B, and XOR.B instructions can also use immediate addressing (6).

The MOV instruction uses all the addressing modes except program-counter relative (7) and memory indirect (8).

Bit manipulation instructions use register direct (1), register indirect (2), or 8-bit absolute (5) addressing to identify a byte operand, and 3-bit immediate addressing to identify a bit within the byte. The BSET, BCLR, BNOT, and BTST instructions can also use register direct addressing (1) to identify the bit.

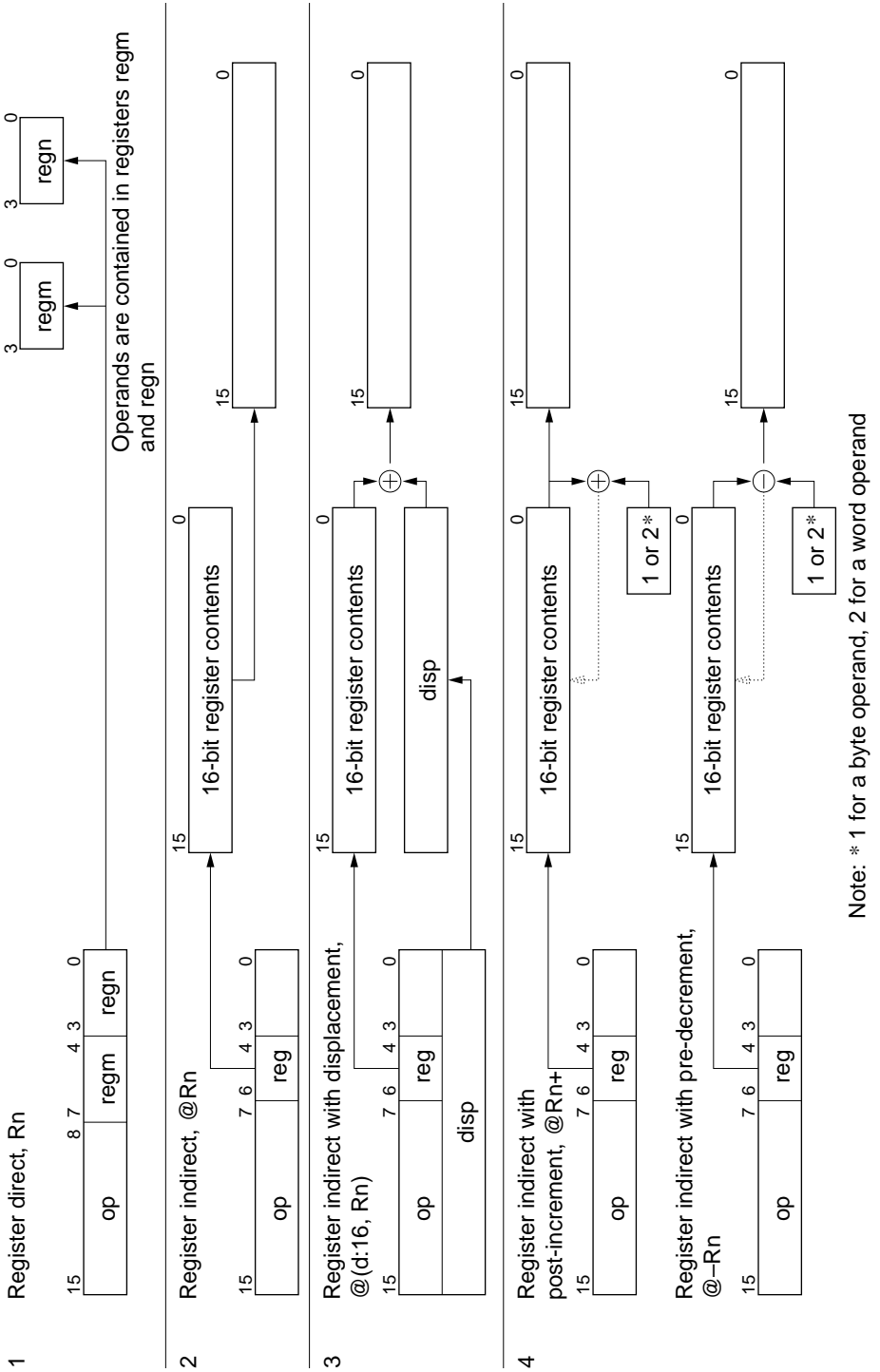
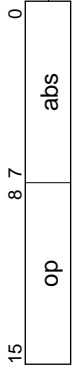
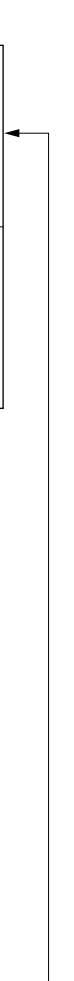
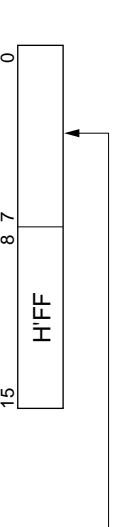
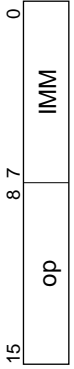
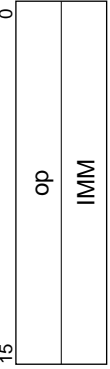

Table 2-2 Effective Address Calculation

Addressing Mode and Instruction Format



Note: * 1 for a byte operand, 2 for a word operand

Table 2-2 Effective Address Calculation (cont)

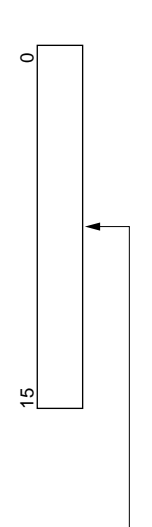
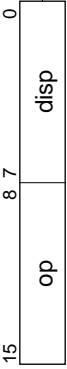
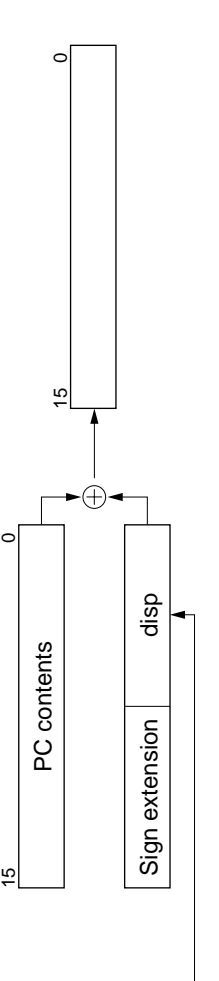
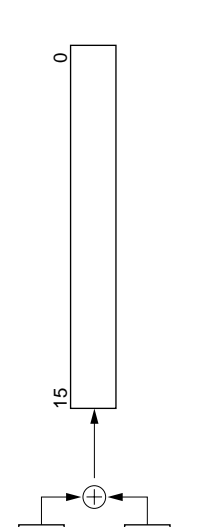
No.	Addressing Mode and Instruction Format	Effective Address Calculation	Effective address
5	Absolute address @aa:8 		
6	Immediate #xx:8  #xx:16 		
7	PC-relative @(d:8, PC) 		

Operand is 1- or 2-byte immediate data

Table 2-2 Effective Address Calculation (cont)

No.	Addressing Mode and Instruction Format	Effective Address Calculation	Effective Address
-----	--	-------------------------------	-------------------

8 Memory indirect, @aa:8

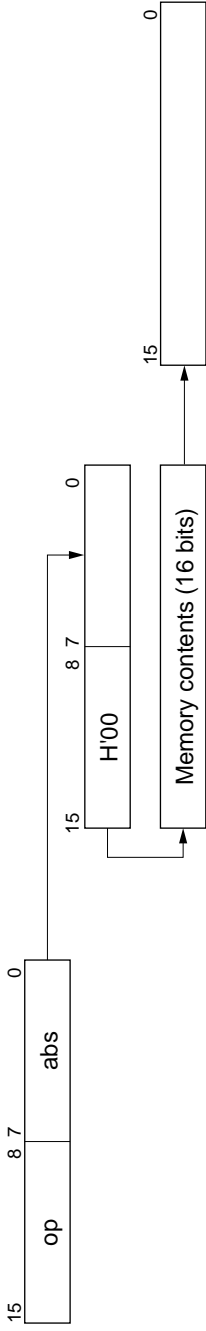

Legend

- reg: General register
- op: Operation code
- disp: Displacement
- IMM: Immediate data
- abs: Absolute address

2.5 Instruction Set

The H8/300 CPU has 57 types of instructions, which are classified by function in table 2-3.

Table 2-3 Instruction Classification

Function	Instructions	Types
Data transfer	MOV, MOVTP ^{*3} , MOVFPE ^{*3} , PUSH ^{*1} , POP ^{*1}	3
Arithmetic operations	ADD, SUB, ADDX, SUBX, INC, DEC, ADDS, SUBS, DAA, DAS, MULXU, DIVXU, CMP, NEG	14
Logic operations	AND, OR, XOR, NOT	4
Shift	SHAL, SHAR, SHLL, SHLR, ROTL, ROTR, ROTXL, ROTXR	8
Bit manipulation	BSET, BCLR, BNOT, BTST, BAND, BAND, BOR, BIOR, BXOR, BIXOR, BLD, BILD, BST, BIST	14
Branch	Bcc ^{*2} , JMP, BSR, JSR, RTS	5
System control	RTE, SLEEP, LDC, STC, ANDC, ORC, XORC, NOP	8
Block data transfer	EEPMOV	1
		Total 57

- Notes: 1. PUSH Rn is equivalent to MOV.W Rn, @-SP.
 POP Rn is equivalent to MOV.W @SP+, Rn.
 2. Bcc is a conditional branch instruction in which cc represents a condition code.
 3. Not supported by the H8/3297 Series.

The following sections give a concise summary of the instructions in each category, and indicate the bit patterns of their object code. The notation used is defined next.

Operation Notation

Rd	General register (destination)	#xx:3	3-Bit immediate data
Rs	General register (source)	#xx:8	8-Bit immediate data
Rn	General register	#xx:16	16-Bit immediate data
(EAd)	Destination operand	disp	Displacement
(EAs)	Source operand	+	Addition
SP	Stack pointer	-	Subtraction
PC	Program counter	×	Multiplication
CCR	Condition code register	÷	Division
N	N (negative) flag of CCR	^	AND logical
Z	Z (zero) flag of CCR	∨	OR logical
V	V (overflow) flag of CCR	⊕	Exclusive OR logical
C	C (carry) flag of CCR	→	Move
#imm	Immediate data	¬	Not

2.5.1 Data Transfer Instructions

Table 2-4 describes the data transfer instructions. Figure 2-5 shows their object code formats.

Table 2-4 Data Transfer Instructions

Instruction	Size*	Function
MOV	B/W	(EAs) → Rd, Rs → (EAd) Moves data between two general registers or between a general register and memory, or moves immediate data to a general register. The Rn, @Rn, @(d:16, Rn), @aa:16, #xx:8 or #xx:16, @-Rn, and @Rn+ addressing modes are available for byte or word data. The @aa:8 addressing mode is available for byte data only. The @-R7 and @R7+ modes require word operands. Do not specify byte size for these two modes.
MOVTPE	B	Not supported by the H8/3437 Series.
MOVFPPE	B	Not supported by the H8/3437 Series.
PUSH	W	Rn → @-SP Pushes a 16-bit general register onto the stack. Equivalent to MOV.W Rn, @-SP.
POP	W	@SP+ → Rn Pops a 16-bit general register from the stack. Equivalent to MOV.W @SP+, Rn.

Note: * Size: Operand size
B: Byte
W: Word

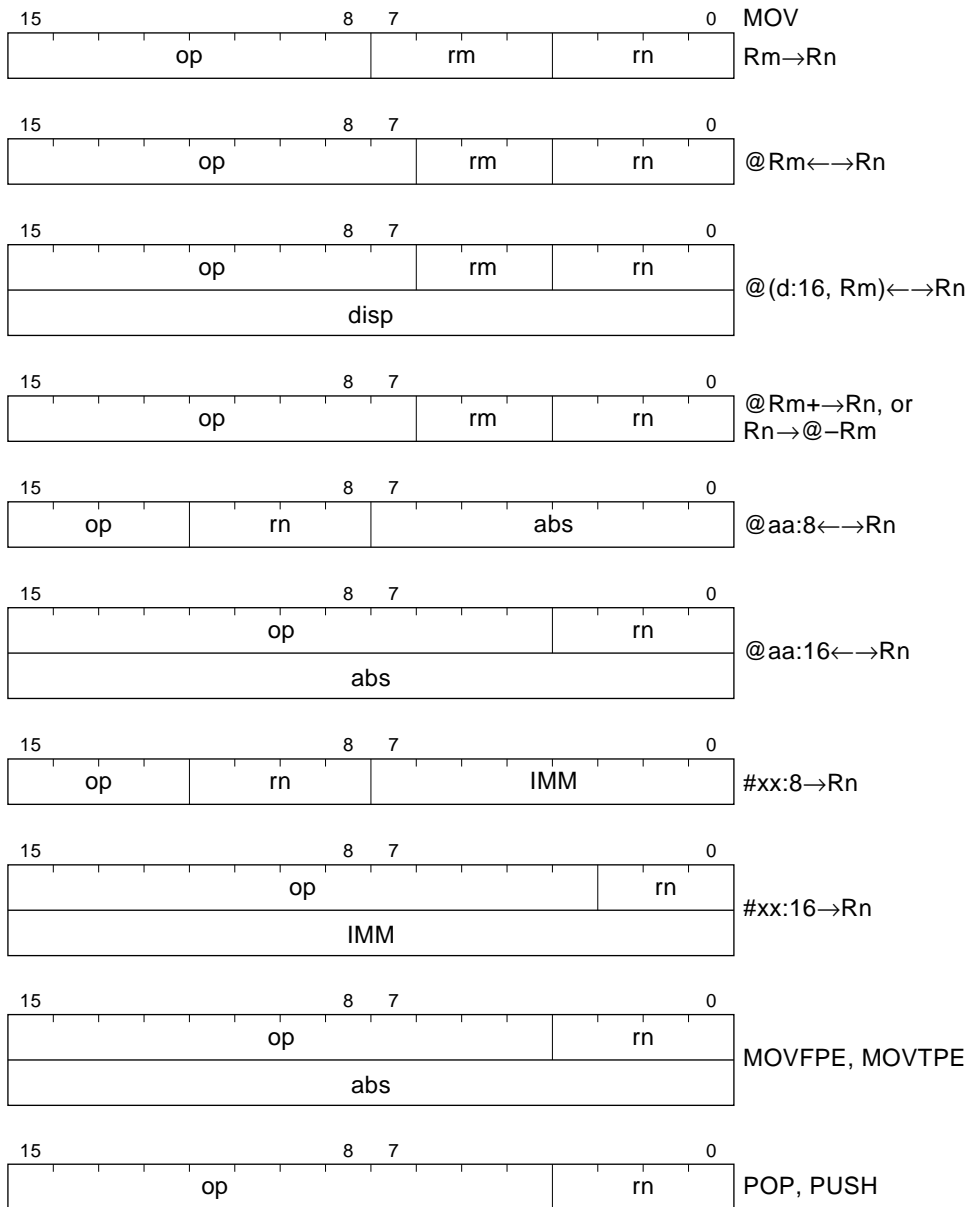

Legend
 op: Operation field
 rm, rn: Register field
 disp: Displacement
 abs: Absolute address
 IMM: Immediate data

Figure 2-5 Data Transfer Instruction Codes

2.5.2 Arithmetic Operations

Table 2-5 describes the arithmetic instructions. See figure 2-6 in section 2.5.4, Shift Operations, for their object codes.

Table 2-5 Arithmetic Instructions

Instruction	Size*	Function
ADD SUB	B/W	$Rd \pm Rs \rightarrow Rd$, $Rd + \#imm \rightarrow Rd$ Performs addition or subtraction on data in two general registers, or addition on immediate data and data in a general register. Immediate data cannot be subtracted from data in a general register. Word data can be added or subtracted only when both words are in general registers.
ADDX SUBX	B	$Rd \pm Rs \pm C \rightarrow Rd$, $Rd \pm \#imm \pm C \rightarrow Rd$ Performs addition or subtraction with carry or borrow on byte data in two general registers, or addition or subtraction on immediate data and data in a general register.
INC DEC	B	$Rd \pm \#1 \rightarrow Rd$ Increments or decrements a general register.
ADDS SUBS	W	$Rd \pm \#imm \rightarrow Rd$ Adds or subtracts immediate data to or from data in a general register. The immediate data must be 1 or 2.
DAA DAS	B	$Rd \text{ decimal adjust} \rightarrow Rd$ Decimal-adjusts (adjusts to packed BCD) an addition or subtraction result in a general register by referring to the CCR.
MULXU	B	$Rd \times Rs \rightarrow Rd$ Performs 8-bit \times 8-bit unsigned multiplication on data in two general registers, providing a 16-bit result.
DIVXU	B	$Rd \div Rs \rightarrow Rd$ Performs 16-bit \div 8-bit unsigned division on data in two general registers, providing an 8-bit quotient and 8-bit remainder.
CMP	B/W	$Rd - Rs$, $Rd - \#imm$ Compares data in a general register with data in another general register or with immediate data. Word data can be compared only between two general registers.
NEG	B	$0 - Rd \rightarrow Rd$ Obtains the two's complement (arithmetic complement) of data in a general register.

Note: * Size: Operand size
B: Byte
W: Word

2.5.3 Logic Operations

Table 2-6 describes the four instructions that perform logic operations. See figure 2-6 in section 2.5.4, Shift Operations, for their object codes.

Table 2-6 Logic Operation Instructions

Instruction	Size*	Function
AND	B	$Rd \wedge Rs \rightarrow Rd$, $Rd \wedge \#imm \rightarrow Rd$ Performs a logical AND operation on a general register and another general register or immediate data.
OR	B	$Rd \vee Rs \rightarrow Rd$, $Rd \vee \#imm \rightarrow Rd$ Performs a logical OR operation on a general register and another general register or immediate data.
XOR	B	$Rd \oplus Rs \rightarrow Rd$, $Rd \oplus \#imm \rightarrow Rd$ Performs a logical exclusive OR operation on a general register and another general register or immediate data.
NOT	B	$\neg (Rd) \rightarrow (Rd)$ Obtains the one's complement (logical complement) of general register contents.

Note: * Size: Operand size
B: Byte

2.5.4 Shift Operations

Table 2-7 describes the eight shift instructions. Figure 2-6 shows the object code formats of the arithmetic, logic, and shift instructions.

Table 2-7 Shift Instructions

Instruction	Size*	Function
SHAL SHAR	B	$Rd \text{ shift} \rightarrow Rd$ Performs an arithmetic shift operation on general register contents.
SHLL SHLR	B	$Rd \text{ shift} \rightarrow Rd$ Performs a logical shift operation on general register contents.
ROTL ROTR	B	$Rd \text{ rotate} \rightarrow Rd$ Rotates general register contents.
ROTXL ROTXR	B	$Rd \text{ rotate through carry} \rightarrow Rd$ Rotates general register contents through the C (carry) bit.

Note: * Size: Operand size
B: Byte

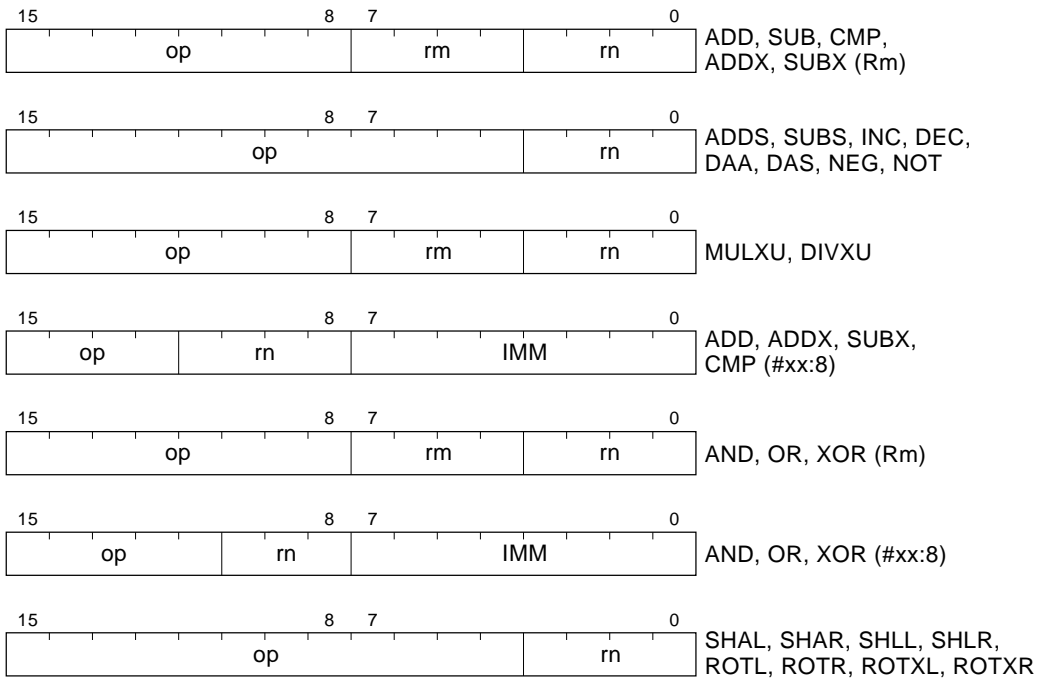

Legend

- op: Operation field
- rm, rn: Register field
- IMM: Immediate data

Figure 2-6 Arithmetic, Logic, and Shift Instruction Codes

2.5.5 Bit Manipulations

Table 2-8 describes the bit-manipulation instructions. Figure 2-7 shows their object code formats.

Table 2-8 Bit-Manipulation Instructions

Instruction	Size*	Function
BSET	B	$1 \rightarrow (\text{<bit no.> of <EAd>})$ Sets a specified bit in a general register or memory to 1. The bit is specified by a bit number, given in 3-bit immediate data or the lower three bits of a general register.
BCLR	B	$0 \rightarrow (\text{<bit no.> of <EAd>})$ Clears a specified bit in a general register or memory to 0. The bit is specified by a bit number, given in 3-bit immediate data or the lower three bits of a general register.
BNOT	B	$\neg (\text{<bit no.> of <EAd>}) \rightarrow (\text{<bit no.> of <EAd>})$ Inverts a specified bit in a general register or memory. The bit is specified by a bit number, given in 3-bit immediate data or the lower three bits of a general register.
BTST	B	$\neg (\text{<bit no.> of <EAd>}) \rightarrow Z$ Tests a specified bit in a general register or memory and sets or clears the Z flag accordingly. The bit is specified by a bit number, given in 3-bit immediate data or the lower three bits of a general register.
BAND	B	$C \wedge (\text{<bit no.> of <EAd>}) \rightarrow C$ ANDs the C flag with a specified bit in a general register or memory.
BIAND		$C \wedge [\neg (\text{<bit no.> of <EAd>})] \rightarrow C$ ANDs the C flag with the inverse of a specified bit in a general register or memory. The bit number is specified by 3-bit immediate data.
BOR	B	$C \vee (\text{<bit no.> of <EAd>}) \rightarrow C$ ORs the C flag with a specified bit in a general register or memory.
BIOR		$C \vee [\neg (\text{<bit no.> of <EAd>})] \rightarrow C$ ORs the C flag with the inverse of a specified bit in a general register or memory. The bit number is specified by 3-bit immediate data.
BXOR	B	$C \oplus (\text{<bit no.> of <EAd>}) \rightarrow C$ XORs the C flag with a specified bit in a general register or memory.

Note: * Size: Operand size
 B: Byte

Table 2-8 Bit-Manipulation Instructions (cont)

Instruction	Size*	Function
BIXOR	B	$C \oplus \neg [(\text{<bit no.> of <EAd>}] \rightarrow C$ XORs the C flag with the inverse of a specified bit in a general register or memory. The bit number is specified by 3-bit immediate data.
BLD	B	$(\text{<bit no.> of <EAd>}) \rightarrow C$ Copies a specified bit in a general register or memory to the C flag.
BILD		$\neg (\text{<bit no.> of <EAd>}) \rightarrow C$ Copies the inverse of a specified bit in a general register or memory to the C flag. The bit number is specified by 3-bit immediate data.
BST	B	$C \rightarrow (\text{<bit no.> of <EAd>})$ Copies the C flag to a specified bit in a general register or memory.
BIST		$\neg C \rightarrow (\text{<bit no.> of <EAd>})$ Copies the inverse of the C flag to a specified bit in a general register or memory. The bit number is specified by 3-bit immediate data.

Note: * Size: Operand size
B: Byte

Notes on Bit Manipulation Instructions: BSET, BCLR, BNOT, BST, and BIST are read-modify-write instructions. They read a byte of data, modify one bit in the byte, then write the byte back. Care is required when these instructions are applied to registers with write-only bits and to the I/O port registers.

Step		Description
1	Read	Read one data byte at the specified address
2	Modify	Modify one bit in the data byte
3	Write	Write the modified data byte back to the specified address

Example 1: BCLR is executed to clear bit 0 in the port 1 data direction register (P1DDR) under the following conditions.

P1₇: Input pin, low
P1₆: Input pin, high
P1₅ – P1₀: Output pins, low

The intended purpose of this BCLR instruction is to switch P1₀ from output to input.

Before Execution of BCLR Instruction

	P1 ₇	P1 ₆	P1 ₅	P1 ₄	P1 ₃	P1 ₂	P1 ₁	P1 ₀
Input/output	Input	Input	Output	Output	Output	Output	Output	Output
Pin state	Low	High	Low	Low	Low	Low	Low	Low
DDR	0	0	1	1	1	1	1	1
DR	1	0	0	0	0	0	0	0

Execution of BCLR Instruction

```
BCLR #0, @P1DDR ;clear bit 0 in data direction register
```

After Execution of BCLR Instruction

	P1 ₇	P1 ₆	P1 ₅	P1 ₄	P1 ₃	P1 ₂	P1 ₁	P1 ₀
Input/output	Output	Output	Output	Output	Output	Output	Output	Input
Pin state	Low	High	Low	Low	Low	Low	Low	High
DDR	1	1	1	1	1	1	1	0
DR	1	0	0	0	0	0	0	0

Explanation: To execute the BCLR instruction, the CPU begins by reading P1DDR. Since P1DDR is a write-only register, it is read as H'FF, even though its true value is H'3F.

Next the CPU clears bit 0 of the read data, changing the value to H'FE.

Finally, the CPU writes this value (H'FE) back to P1DDR to complete the BCLR instruction.

As a result, P1₀DDR is cleared to 0, making P1₀ an input pin. In addition, P1₇DDR and P1₆DDR are set to 1, making P1₇ and P1₆ output pins.

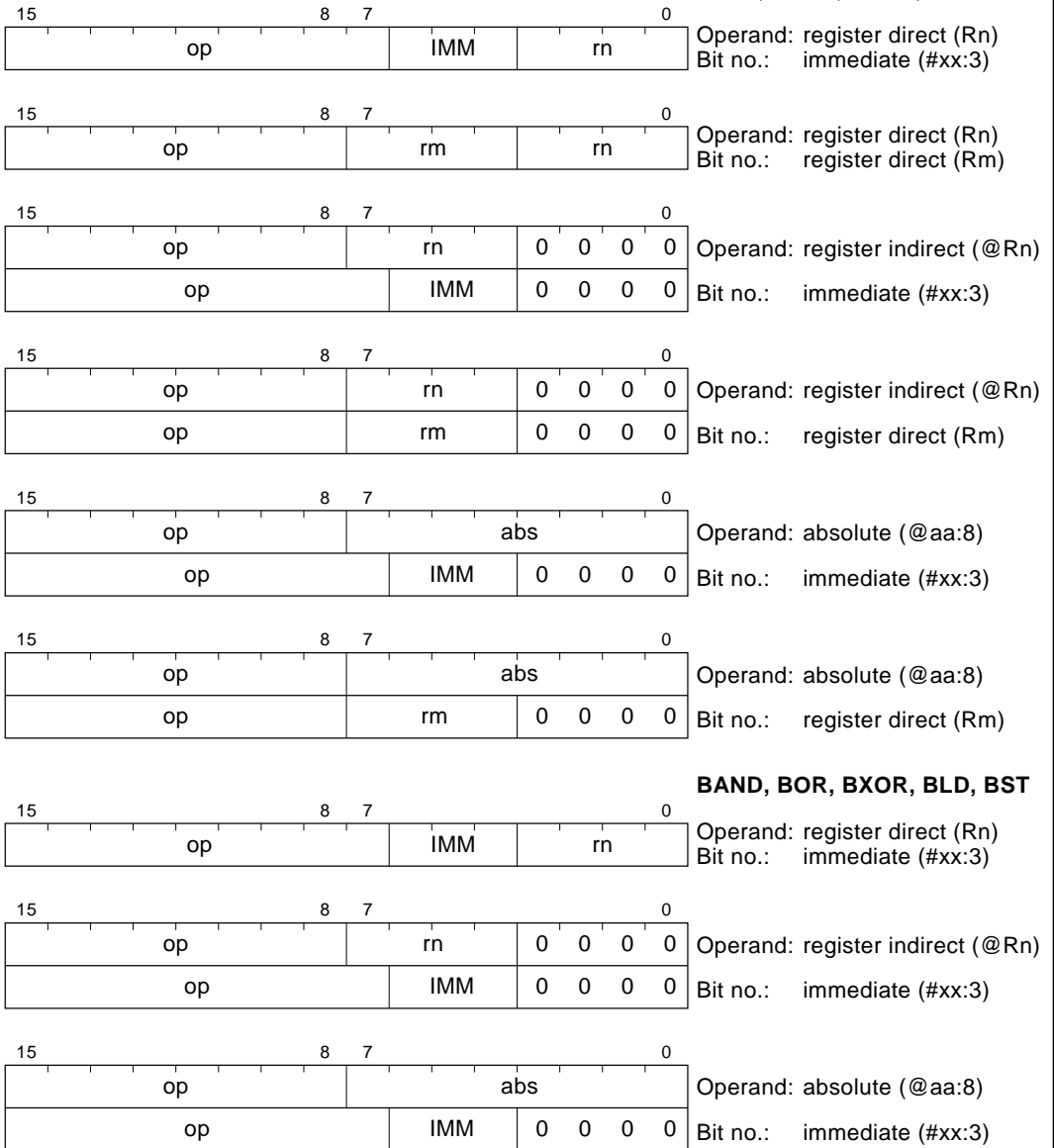
BSET, BCLR, BNOT, BTST**Legend**

op: Operation field
 rm, rn: Register field
 abs: Absolute address
 IMM: Immediate data

Figure 2-7 Bit Manipulation Instruction Codes

2.5.6 Branching Instructions

Table 2-9 describes the branching instructions. Figure 2-8 shows their object code formats.

Table 2-9 Branching Instructions

Instruction	Size	Function																																																																				
Bcc	—	Branches if condition cc is true.																																																																				
		<table border="1"> <thead> <tr> <th>Mnemonic</th> <th>cc field</th> <th>Description</th> <th>Condition</th> </tr> </thead> <tbody> <tr> <td>BRA (BT)</td> <td>0 0 0 0</td> <td>Always (true)</td> <td>Always</td> </tr> <tr> <td>BRN (BF)</td> <td>0 0 0 1</td> <td>Never (false)</td> <td>Never</td> </tr> <tr> <td>BHI</td> <td>0 0 1 0</td> <td>High</td> <td>$C \vee Z = 0$</td> </tr> <tr> <td>BLS</td> <td>0 0 1 1</td> <td>Low or same</td> <td>$C \vee Z = 1$</td> </tr> <tr> <td>BCC (BHS)</td> <td>0 1 0 0</td> <td>Carry clear (High or same)</td> <td>$C = 0$</td> </tr> <tr> <td>BCS (BLO)</td> <td>0 1 0 1</td> <td>Carry set (low)</td> <td>$C = 1$</td> </tr> <tr> <td>BNE</td> <td>0 1 1 0</td> <td>Not equal</td> <td>$Z = 0$</td> </tr> <tr> <td>BEQ</td> <td>0 1 1 1</td> <td>Equal</td> <td>$Z = 1$</td> </tr> <tr> <td>BVC</td> <td>1 0 0 0</td> <td>Overflow clear</td> <td>$V = 0$</td> </tr> <tr> <td>BVS</td> <td>1 0 0 1</td> <td>Overflow set</td> <td>$V = 1$</td> </tr> <tr> <td>BPL</td> <td>1 0 1 0</td> <td>Plus</td> <td>$N = 0$</td> </tr> <tr> <td>BMI</td> <td>1 0 1 1</td> <td>Minus</td> <td>$N = 1$</td> </tr> <tr> <td>BGE</td> <td>1 1 0 0</td> <td>Greater or equal</td> <td>$N \oplus V = 0$</td> </tr> <tr> <td>BLT</td> <td>1 1 0 1</td> <td>Less than</td> <td>$N \oplus V = 1$</td> </tr> <tr> <td>BGT</td> <td>1 1 1 0</td> <td>Greater than</td> <td>$Z \vee (N \oplus V) = 0$</td> </tr> <tr> <td>BLE</td> <td>1 1 1 1</td> <td>Less or equal</td> <td>$Z \vee (N \oplus V) = 1$</td> </tr> </tbody> </table>	Mnemonic	cc field	Description	Condition	BRA (BT)	0 0 0 0	Always (true)	Always	BRN (BF)	0 0 0 1	Never (false)	Never	BHI	0 0 1 0	High	$C \vee Z = 0$	BLS	0 0 1 1	Low or same	$C \vee Z = 1$	BCC (BHS)	0 1 0 0	Carry clear (High or same)	$C = 0$	BCS (BLO)	0 1 0 1	Carry set (low)	$C = 1$	BNE	0 1 1 0	Not equal	$Z = 0$	BEQ	0 1 1 1	Equal	$Z = 1$	BVC	1 0 0 0	Overflow clear	$V = 0$	BVS	1 0 0 1	Overflow set	$V = 1$	BPL	1 0 1 0	Plus	$N = 0$	BMI	1 0 1 1	Minus	$N = 1$	BGE	1 1 0 0	Greater or equal	$N \oplus V = 0$	BLT	1 1 0 1	Less than	$N \oplus V = 1$	BGT	1 1 1 0	Greater than	$Z \vee (N \oplus V) = 0$	BLE	1 1 1 1	Less or equal	$Z \vee (N \oplus V) = 1$
Mnemonic	cc field	Description	Condition																																																																			
BRA (BT)	0 0 0 0	Always (true)	Always																																																																			
BRN (BF)	0 0 0 1	Never (false)	Never																																																																			
BHI	0 0 1 0	High	$C \vee Z = 0$																																																																			
BLS	0 0 1 1	Low or same	$C \vee Z = 1$																																																																			
BCC (BHS)	0 1 0 0	Carry clear (High or same)	$C = 0$																																																																			
BCS (BLO)	0 1 0 1	Carry set (low)	$C = 1$																																																																			
BNE	0 1 1 0	Not equal	$Z = 0$																																																																			
BEQ	0 1 1 1	Equal	$Z = 1$																																																																			
BVC	1 0 0 0	Overflow clear	$V = 0$																																																																			
BVS	1 0 0 1	Overflow set	$V = 1$																																																																			
BPL	1 0 1 0	Plus	$N = 0$																																																																			
BMI	1 0 1 1	Minus	$N = 1$																																																																			
BGE	1 1 0 0	Greater or equal	$N \oplus V = 0$																																																																			
BLT	1 1 0 1	Less than	$N \oplus V = 1$																																																																			
BGT	1 1 1 0	Greater than	$Z \vee (N \oplus V) = 0$																																																																			
BLE	1 1 1 1	Less or equal	$Z \vee (N \oplus V) = 1$																																																																			
JMP	—	Branches unconditionally to a specified address.																																																																				
JSR	—	Branches to a subroutine at a specified address.																																																																				
BSR	—	Branches to a subroutine at a specified displacement from the current address.																																																																				
RTS	—	Returns from a subroutine.																																																																				

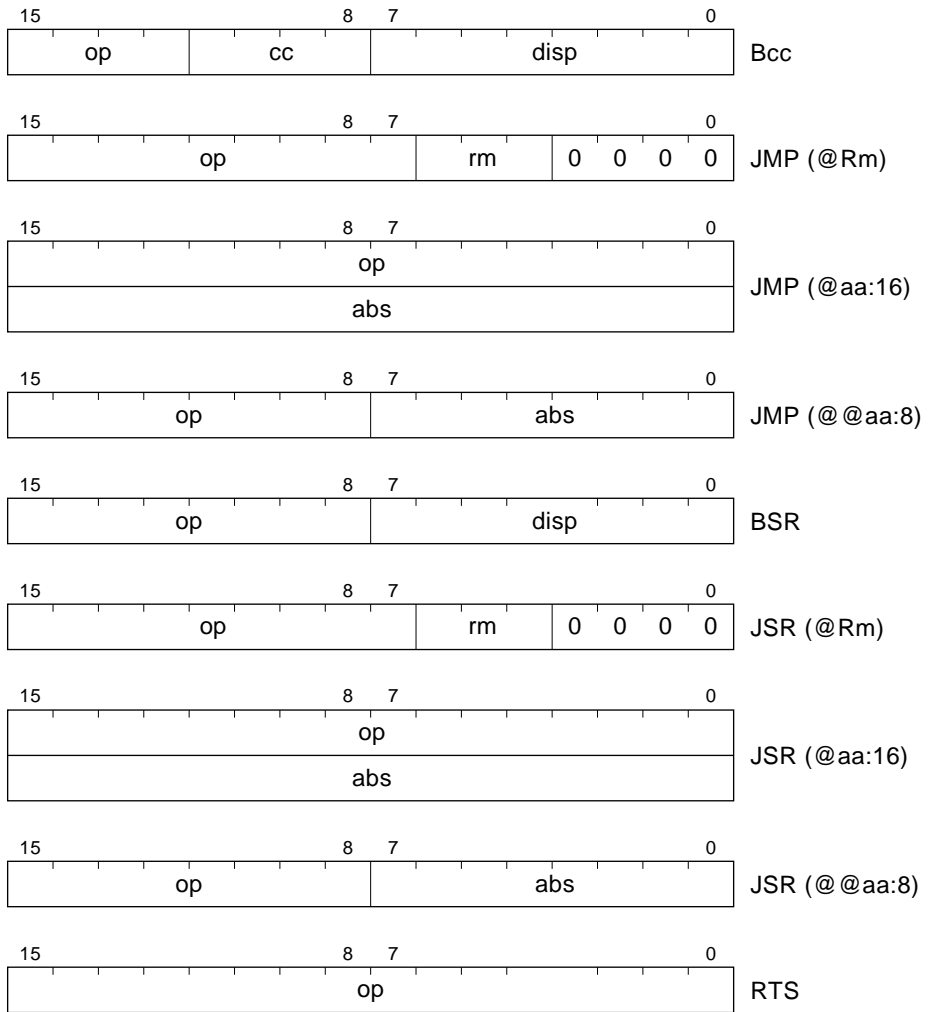

Legend

- op: Operation field
- cc: Condition field
- rm: Register field
- disp: Displacement
- abs: Absolute address

Figure 2-8 Branching Instruction Codes

2.5.7 System Control Instructions

Table 2-10 describes the system control instructions. Figure 2-9 shows their object code formats.

Table 2-10 System Control Instructions

Inst5ruction	Size	Function
RTE	—	Returns from an exception-handling routine.
SLEEP	—	Causes a transition to the power-down state.
LDC	B	$R_s \rightarrow CCR$, $\#imm \rightarrow CCR$ Moves immediate data or general register contents to the condition code register.
STC	B	$CCR \rightarrow R_d$ Copies the condition code register to a specified general register.
ANDC	B	$CCR \wedge \#imm \rightarrow CCR$ Logically ANDs the condition code register with immediate data.
ORC	B	$CCR \vee \#imm \rightarrow CCR$ Logically ORs the condition code register with immediate data.
XORC	B	$CCR \oplus \#imm \rightarrow CCR$ Logically exclusive-ORs the condition code register with immediate data.
NOP	—	$PC + 2 \rightarrow PC$ Only increments the program counter.

Note: * Size: Operand size
B: Byte

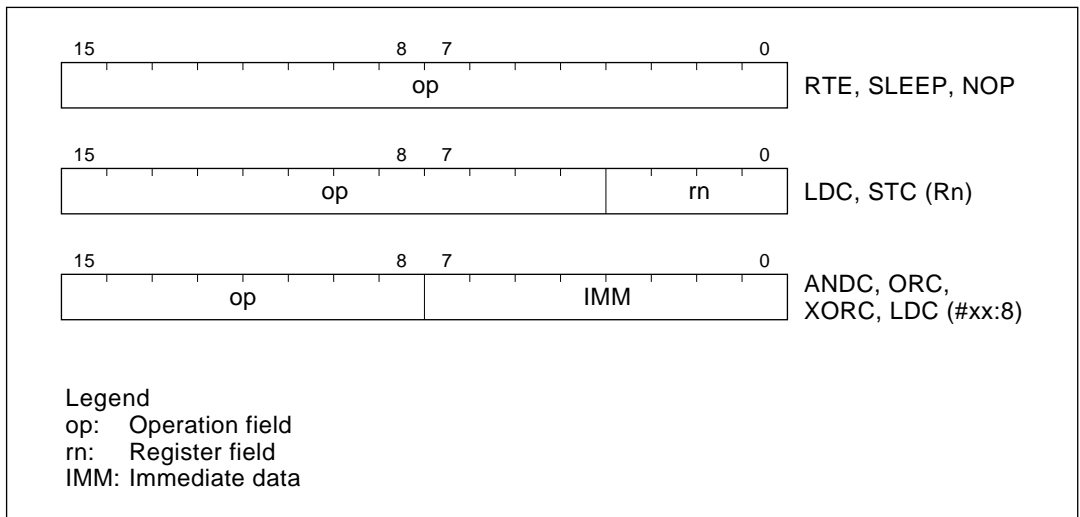

Figure 2-9 System Control Instruction Codes

2.5.8 Block Data Transfer Instruction

Table 2-11 describes the EEPMOV instruction. Figure 2-10 shows its object code format.

Table 2-11 Block Data Transfer Instruction/EEPROM Write Operation

Instruction	Size	Function
EEPMOV	—	<p>if R4L \neq 0 then</p> <p style="padding-left: 40px;">repeat @R5+ \rightarrow @R6+ R4L - 1 \rightarrow R4L</p> <p style="padding-left: 40px;">until R4L = 0</p> <p>else next;</p> <p>Moves a data block according to parameters set in general registers R4L, R5, and R6.</p> <p>R4L: size of block (bytes) R5: starting source address R6: starting destination address</p> <p>Execution of the next instruction starts as soon as the block transfer is completed.</p>

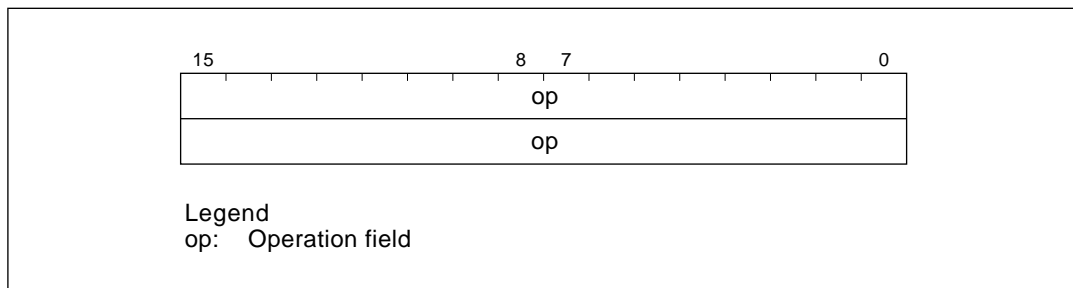
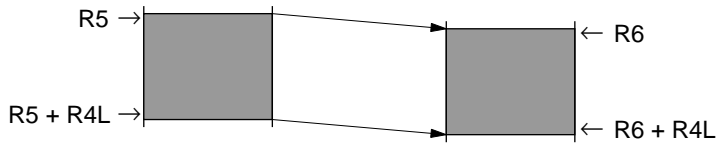

Figure 2-10 Block Data Transfer Instruction/EEPROM Write Operation Code

Notes on EEPMOV Instruction

1. The EEPMOV instruction is a block data transfer instruction. It moves the number of bytes specified by R4L from the address specified by R5 to the address specified by R6.



2. When setting R4L and R6, make sure that the final destination address (R6 + R4L) does not exceed H'FFFF. The value in R6 must not change from H'FFFF to H'0000 during execution of the instruction.

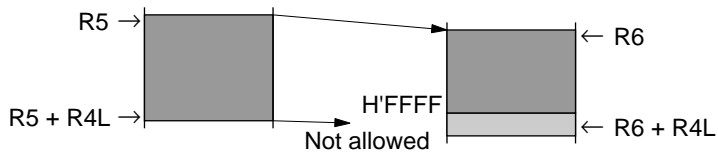

2.6 CPU States

2.6.1 Overview

The CPU has three states: the program execution state, exception-handling state, and power-down state. The power-down state is further divided into three modes: sleep mode, software standby mode, and hardware standby mode. Figure 2-11 summarizes these states, and figure 2-12 shows a map of the state transitions.

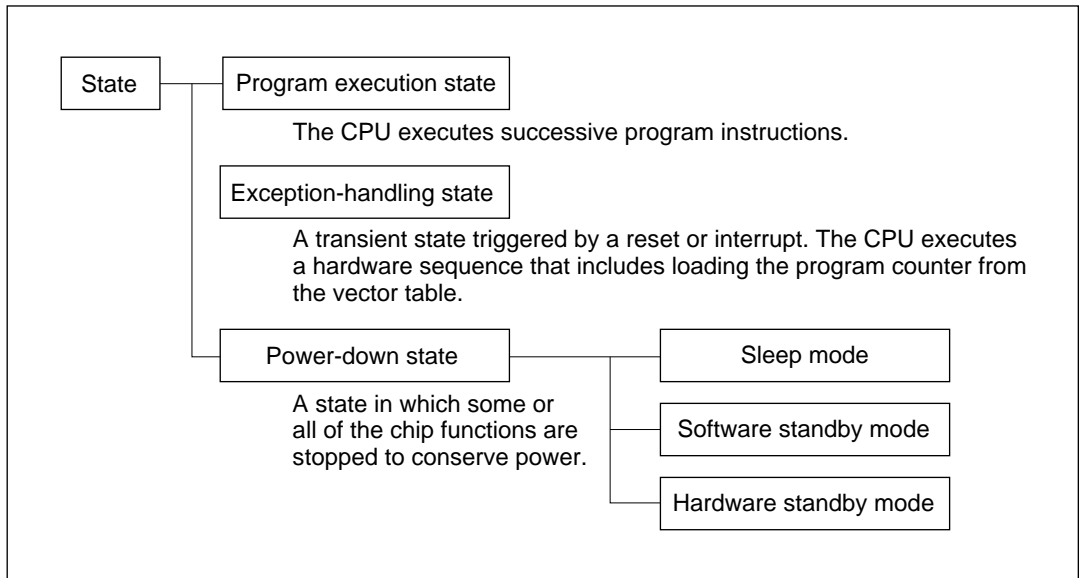
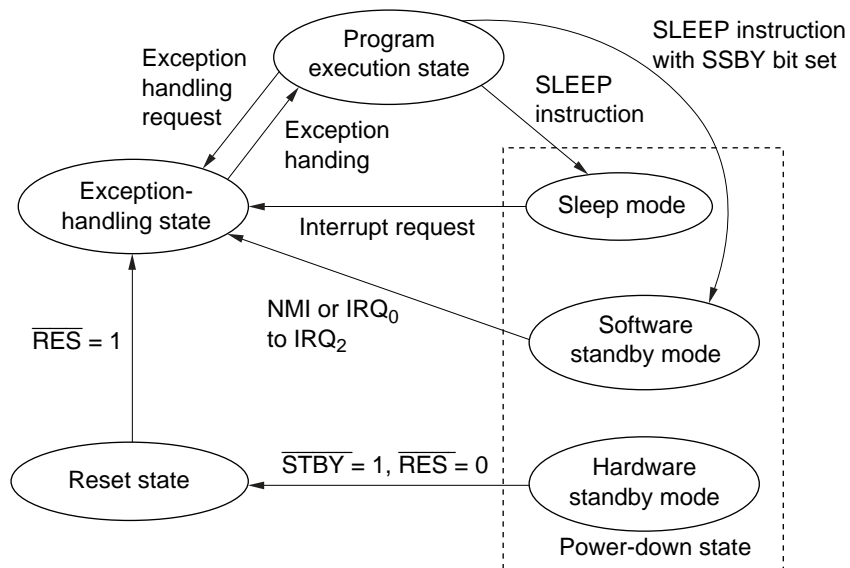

Figure 2-11 Operating States



- Notes: 1. A transition to the reset state occurs when \overline{RES} goes low, except when the chip is in the hardware standby mode.
 2. A transition from any state to the hardware standby mode occurs when \overline{STBY} goes low.

Figure 2-12 State Transitions

2.6.2 Program Execution State

In this state the CPU executes program instructions.

2.6.3 Exception-Handling State

The exception-handling state is a transient state that occurs when the CPU is reset or interrupted and changes its normal processing flow. In interrupt exception handling, the CPU references the stack pointer (R7) and saves the program counter and condition code register on the stack. For further details see section 4, Exception Handling.

2.6.4 Power-Down State

The power-down state includes three modes: sleep mode, software standby mode, and hardware standby mode.

(1) Sleep Mode: Is entered when a SLEEP instruction is executed. The CPU halts, but CPU register contents remain unchanged and the on-chip supporting modules continue to function.

(2) Software Standby Mode: Is entered if the SLEEP instruction is executed while the SSBY (Software Standby) bit in the system control register (SYSCR) is set. The CPU and all on-chip supporting modules halt. The on-chip supporting modules are initialized, but the contents of the on-chip RAM and CPU registers remain unchanged as long as a specified voltage is supplied. I/O port outputs also remain unchanged.

(3) Hardware Standby Mode: Is entered when the input at the $\overline{\text{STBY}}$ pin goes low. All chip functions halt, including I/O port output. The on-chip supporting modules are initialized, but on-chip RAM contents are held.

See section 15, Power-Down State, for further information.

2.7 Access Timing and Bus Cycle

The CPU is driven by the system clock (ϕ). The period from one rising edge of the system clock to the next is referred to as a “state.” Memory access is performed in a two- or three-state bus cycle. On-chip memory, on-chip supporting modules, and external devices are accessed in different bus cycles as described below.

2.7.1 Access to On-Chip Memory (RAM and ROM)

On-chip ROM and RAM are accessed in a cycle of two states designated T_1 and T_2 . Either byte or word data can be accessed, via a 16-bit data bus. Figure 2-13 shows the on-chip memory access cycle. Figure 2-14 shows the associated pin states.

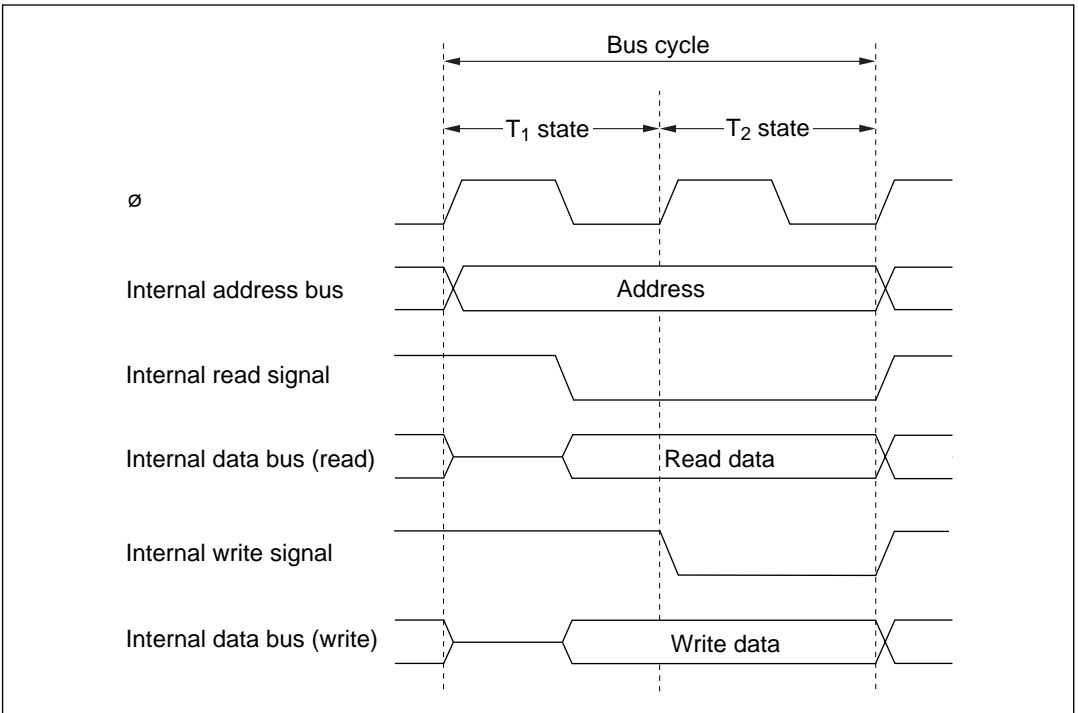

Figure 2-13 On-Chip Memory Access Cycle

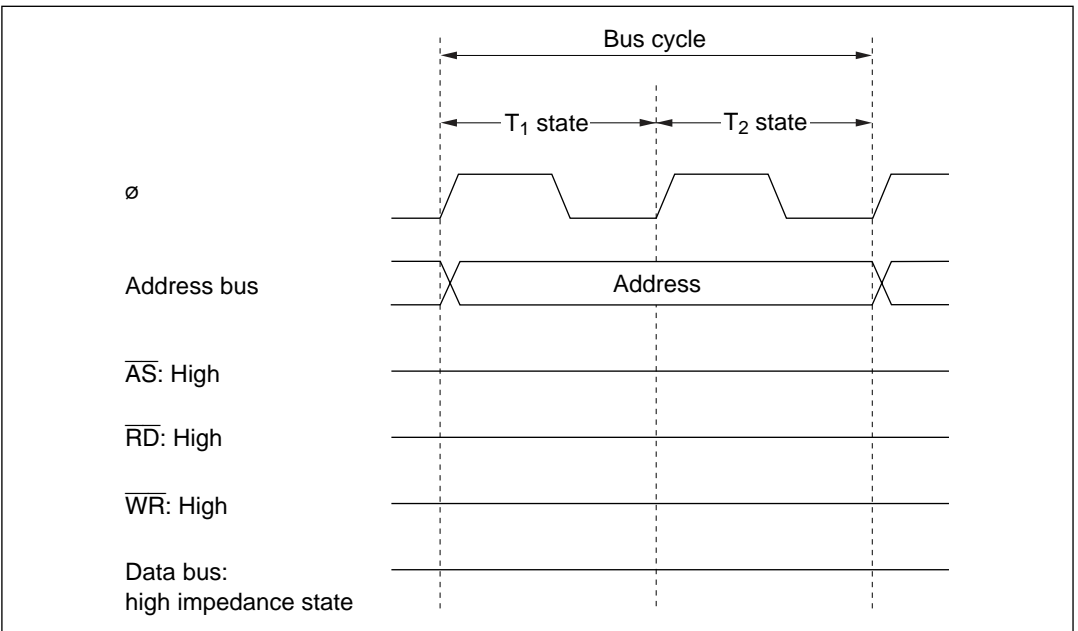

Figure 2-14 Pin States during On-Chip Memory Access Cycle

2.7.2 Access to On-Chip Register Field and External Devices

The on-chip supporting module registers and external devices are accessed in a cycle consisting of three states: T_1 , T_2 , and T_3 . Only one byte of data can be accessed per cycle, via an 8-bit data bus. Access to word data or instruction codes requires two consecutive cycles (six states).

Figure 2-15 shows the access cycle for the on-chip register field. Figure 2-16 shows the associated pin states. Figures 2-17 (a) and (b) show the read and write access timing for external devices.

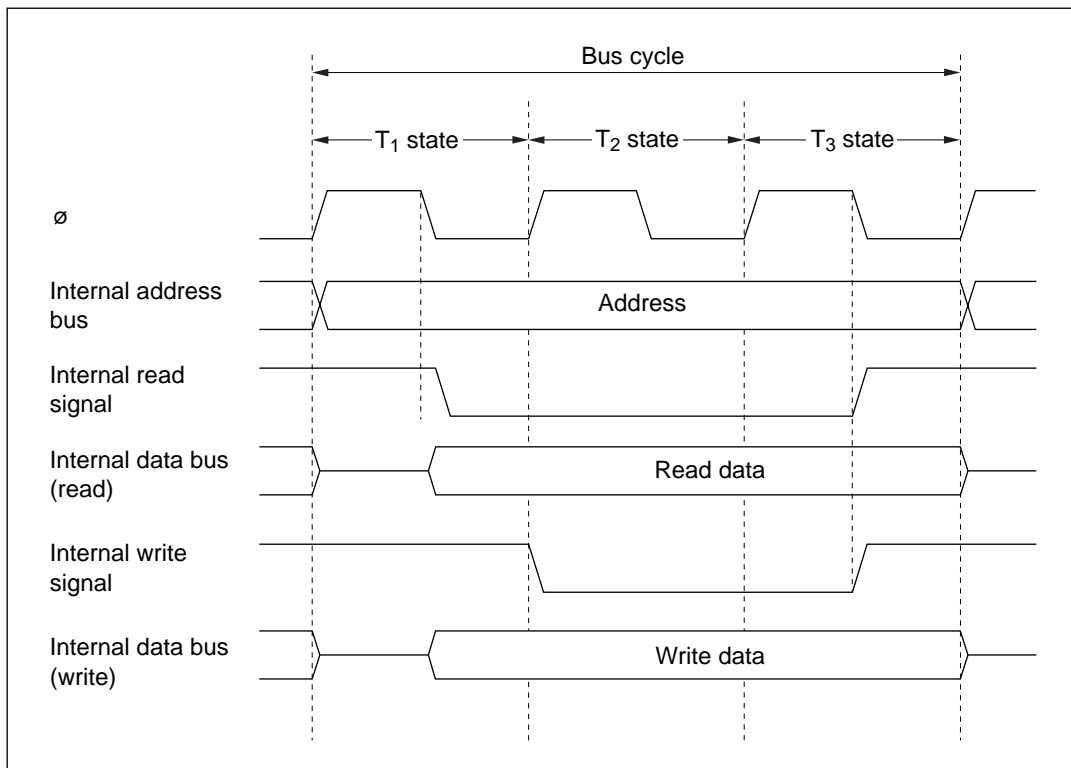

Figure 2-15 On-Chip Register Field Access Cycle

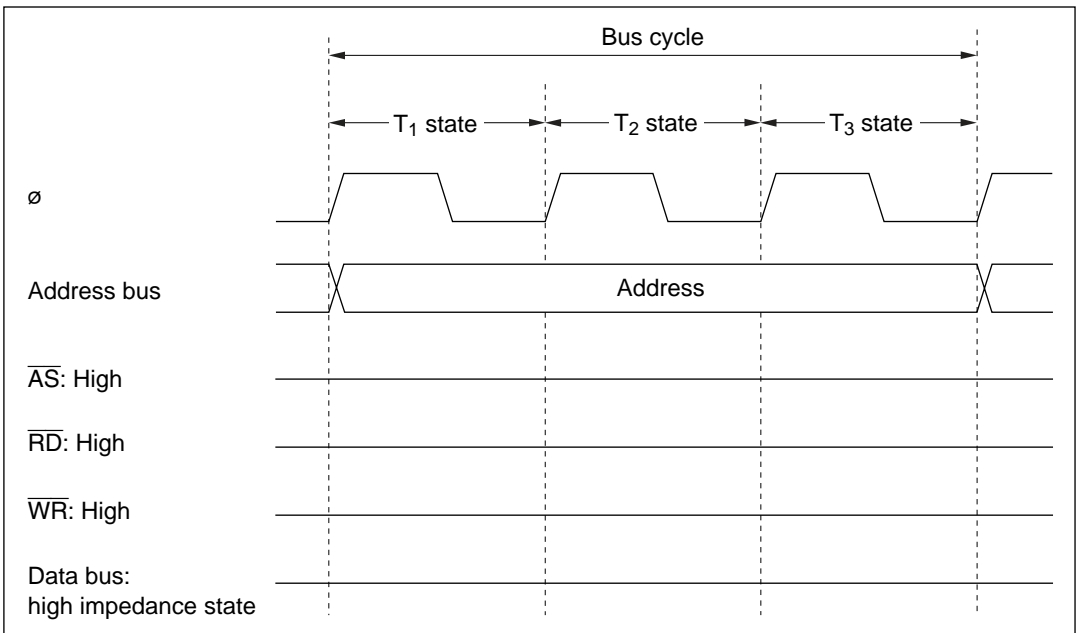

Figure 2-16 Pin States during On-Chip Register Field Access Cycle

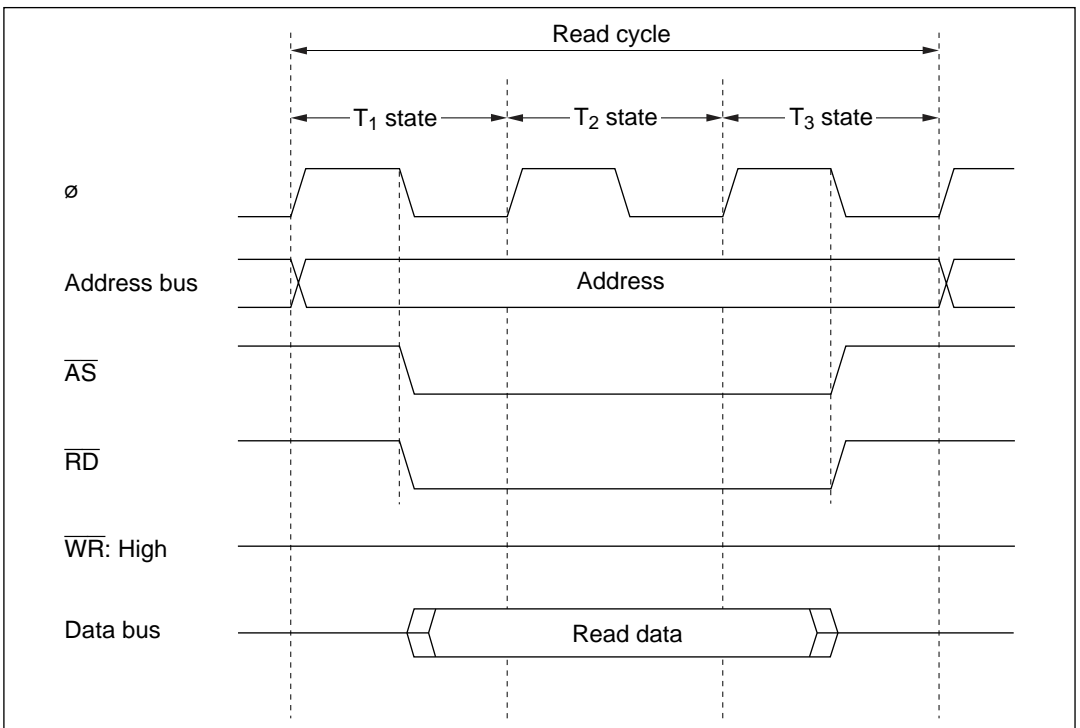

Figure 2-17 (a) External Device Access Timing (Read)

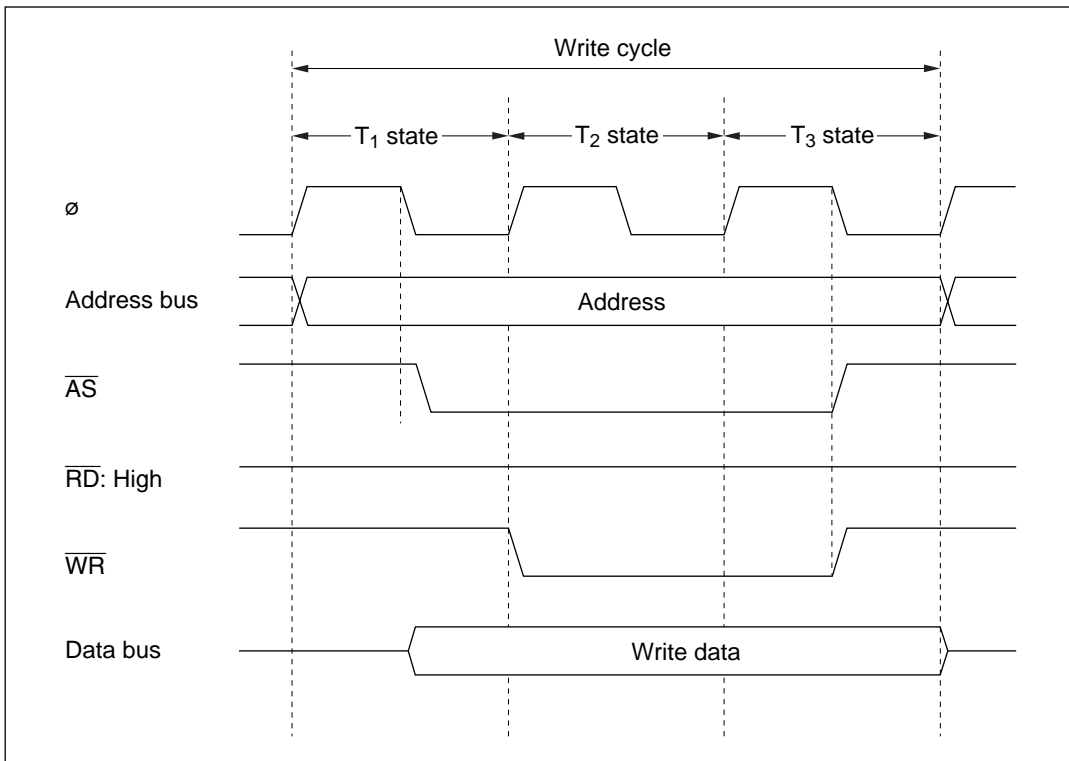

Figure 2-17 (b) External Device Access Timing (Write)

Section 3 MCU Operating Modes and Address Space

3.1 Overview

3.1.1 Mode Selection

The H8/3297 Series operates in three modes numbered 1, 2, and 3. The mode is selected by the inputs at the mode pins (MD_1 and MD_0). See table 3-1.

Table 3-1 Operating Modes

Mode	MD_1	MD_0	Address space	On-chip ROM	On-chip RAM
Mode 0	Low	Low	—	—	—
Mode 1	Low	High	Expanded	Disabled	Enabled*
Mode 2	High	Low	Expanded	Enabled	Enabled*
Mode 3	High	High	Single-chip	Enabled	Enabled

Note: * If the RAME bit in the system control register (SYSCR) is cleared to 0, off-chip memory can be accessed instead.

Modes 1 and 2 are expanded modes that permit access to off-chip memory and peripheral devices. The maximum address space supported by these externally expanded modes is 64 kbytes.

In mode 3 (single-chip mode), only on-chip ROM and RAM and the on-chip register field are used. All ports are available for general-purpose input and output.

Mode 0 is inoperative in the H8/3297 Series. Avoid setting the mode pins to mode 0.

3.1.2 Mode and System Control Registers

Table 3-2 lists the registers related to the chip's operating mode: the system control register (SYSCR) and mode control register (MDCR). The mode control register indicates the inputs to the mode pins MD₁ and MD₀.

Table 3-2 Mode and System Control Registers

Name	Abbreviation	Read/Write	Address
System control register	SYSCR	R/W	H'FFC4
Mode control register	MDCR	R	H'FFC5

3.2 System Control Register (SYSCR)

Bit	7	6	5	4	3	2	1	0
	SSBY	STS2	STS1	STS0	XRST	NMIEG	—	RAME
Initial value	0	0	0	0	1	0	1	1
Read/Write	R/W	R/W	R/W	R/W	R	R/W	—	R/W

The system control register (SYSCR) is an 8-bit register that controls the operation of the chip.

Bit 7—Software Standby (SSBY): Enables transition to the software standby mode. For details, see section 15, Power-Down State.

On recovery from software standby mode by an external interrupt, the SSBY bit remains set to 1. It can be cleared by writing 0.

Bit 7

SSBY	Description
0	The SLEEP instruction causes a transition to sleep mode. (Initial value)
1	The SLEEP instruction causes a transition to software standby mode.

Bits 6 to 4—Standby Timer Select 2 to 0 (STS2 to STS0): These bits select the clock settling time when the chip recovers from the software standby mode by an external interrupt. During the selected time the CPU and on-chip supporting modules continue to stand by. These bits should be set according to the clock frequency so that the settling time is at least 8 ms. For specific settings, see section 15.3.3, Clock Settling Time for Exit from Software Standby Mode.

Bit 6 STS2	Bit 5 STS1	Bit 4 STS0	Description
0	0	0	Settling time = 8,192 states (Initial value)
0	0	1	Settling time = 16,384 states
0	1	0	Settling time = 32,768 states
0	1	1	Settling time = 65,536 states
1	0	—	Settling time = 131,072 states
1	1	—	Disabled

Bit 3—External Reset (XRST): Indicates the source of a reset. A reset can be generated by input of an external reset signal, or by a watchdog timer overflow when the watchdog timer is used. XRST is a read-only bit. It is set to 1 by an external reset, and cleared to 0 by watchdog timer overflow.

Bit 3 XRST	Description
0	Reset was caused by watchdog timer overflow.
1	Reset was caused by external input. (Initial value)

Bit 2—NMI Edge (NMIEG): Selects the valid edge of the NMI input.

Bit 2 NMIEG	Description
0	An interrupt is requested on the falling edge of the $\overline{\text{NMI}}$ input. (Initial value)
1	An interrupt is requested on the rising edge of the $\overline{\text{NMI}}$ input.

Bit 1—Reserved: This bit cannot be modified and is always read as 1.

Bit 0—RAM Enable (RAME): Enables or disables the on-chip RAM. The RAME bit is initialized by a reset, but is not initialized in the software standby mode.

Bit 0

RAME	Description
0	The on-chip RAM is disabled.
1	The on-chip RAM is enabled. (Initial value)

3.3 Mode Control Register (MDCR)

Bit	7	6	5	4	3	2	1	0
	—	—	—	—	—	—	MDS1	MDS0
Initial value	1	1	1	0	0	1	*	*
Read/Write	—	—	—	—	—	—	R	R

Note: * Initialized according to MD₁ and MD₀ inputs.

The mode control register (MDCR) is an 8-bit register that indicates the operating mode of the chip.

Bits 7 to 5—Reserved: These bits cannot be modified and are always read as 1.

Bits 4 and 3—Reserved: These bits cannot be modified and are always read as 0.

Bit 2—Reserved: This bit cannot be modified and is always read as 1.

Bits 1 and 0—Mode Select 1 and 0 (MDS1 and MDS0): These bits indicate the values of the mode pins (MD₁ and MD₀), thereby indicating the current operating mode of the chip. MDS1 corresponds to MD₁ and MDS0 to MD₀. These bits can be read but not written. When the mode control register is read, the levels at the mode pins (MD₁ and MD₀) are latched in these bits.

3.4 Address Space Map in Each Operating Mode

Figures 3-1 to 3-4 show memory maps of the H8/3297, H8/3296, H8/3294, and H8/3292 in modes 1, 2, and 3.

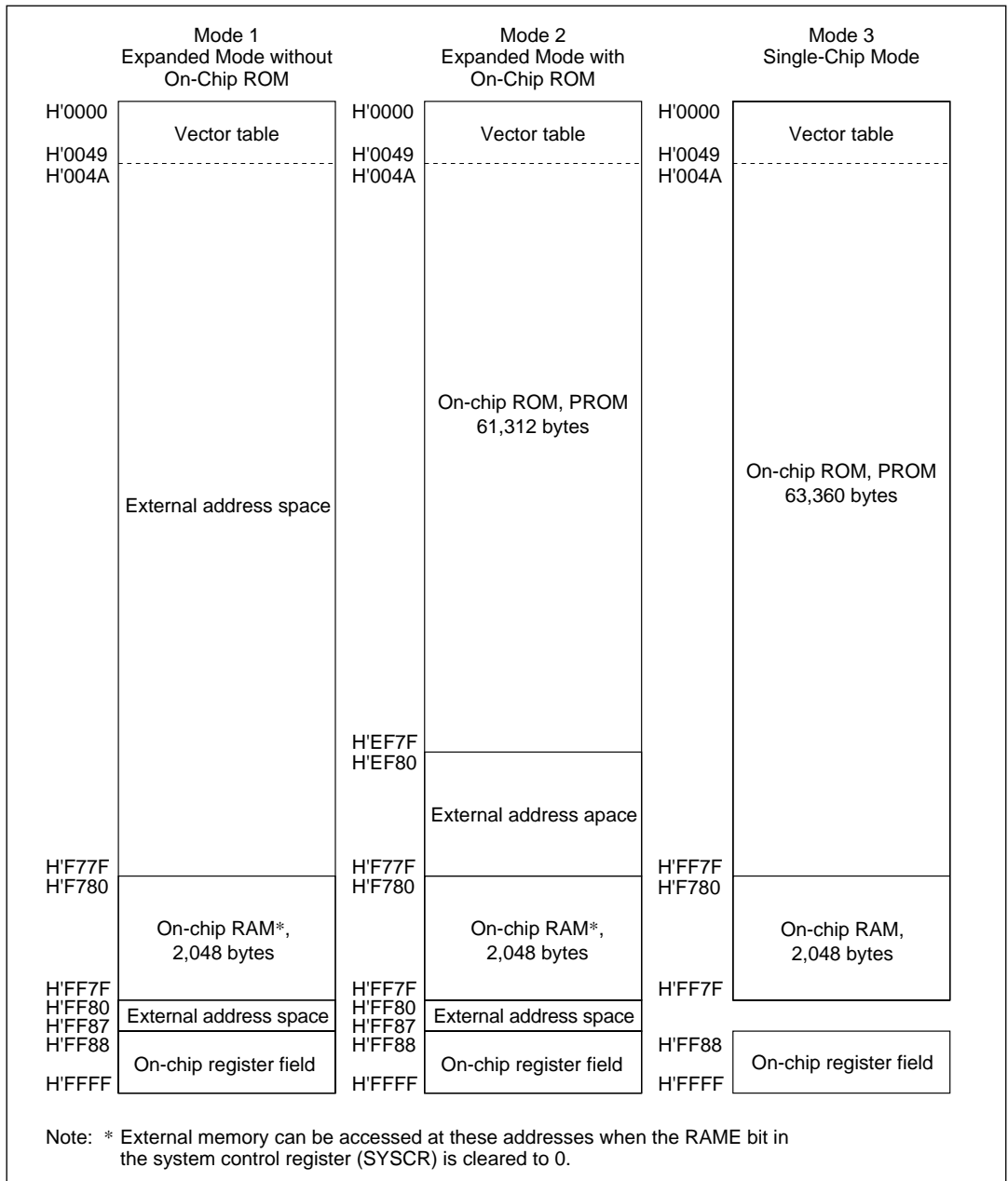

Figure 3-1 H8/3297 Address Space Map

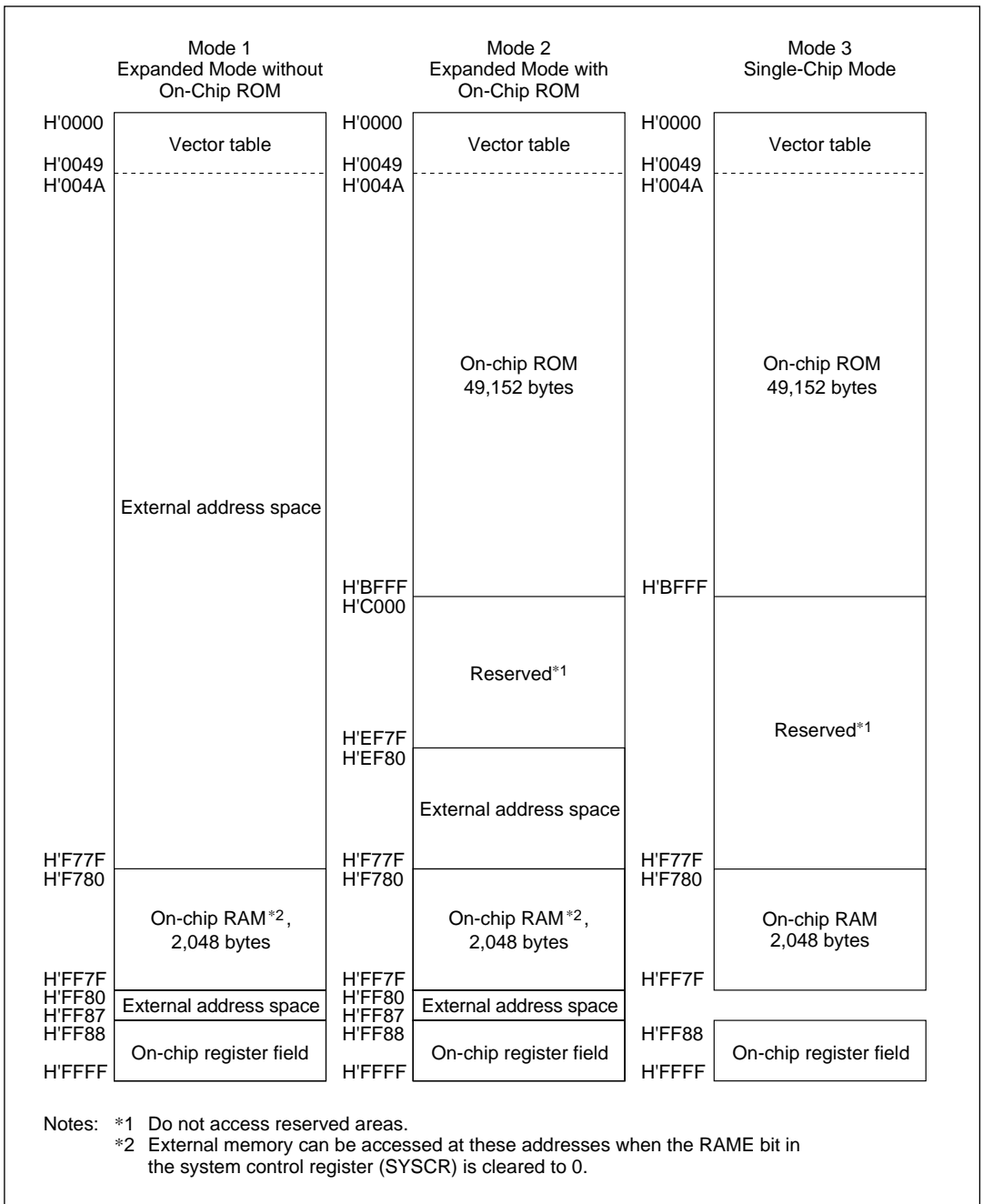

Figure 3-2 H8/3296 Address Space Map

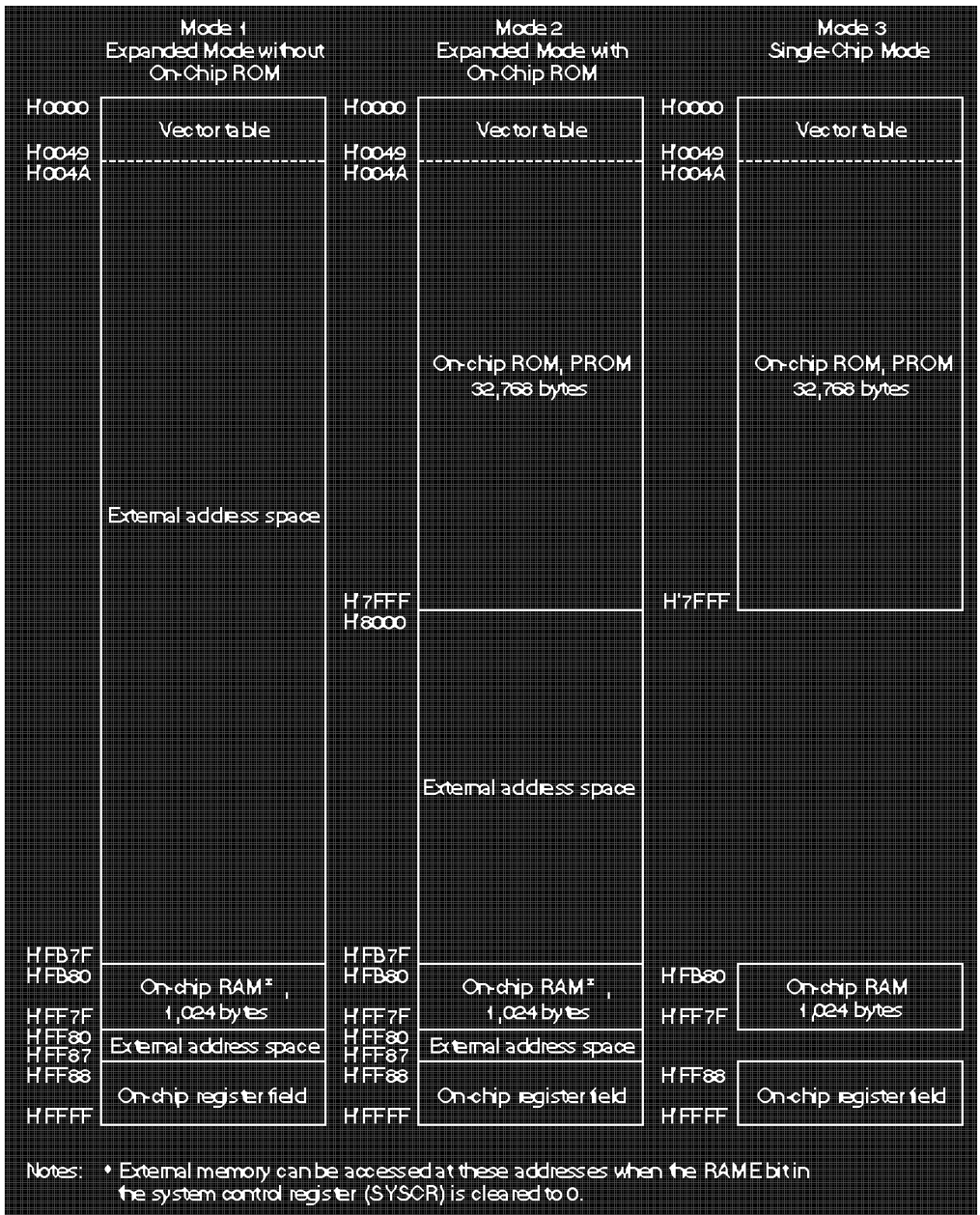

Figure 3-3 H8/3294 Address Space Map

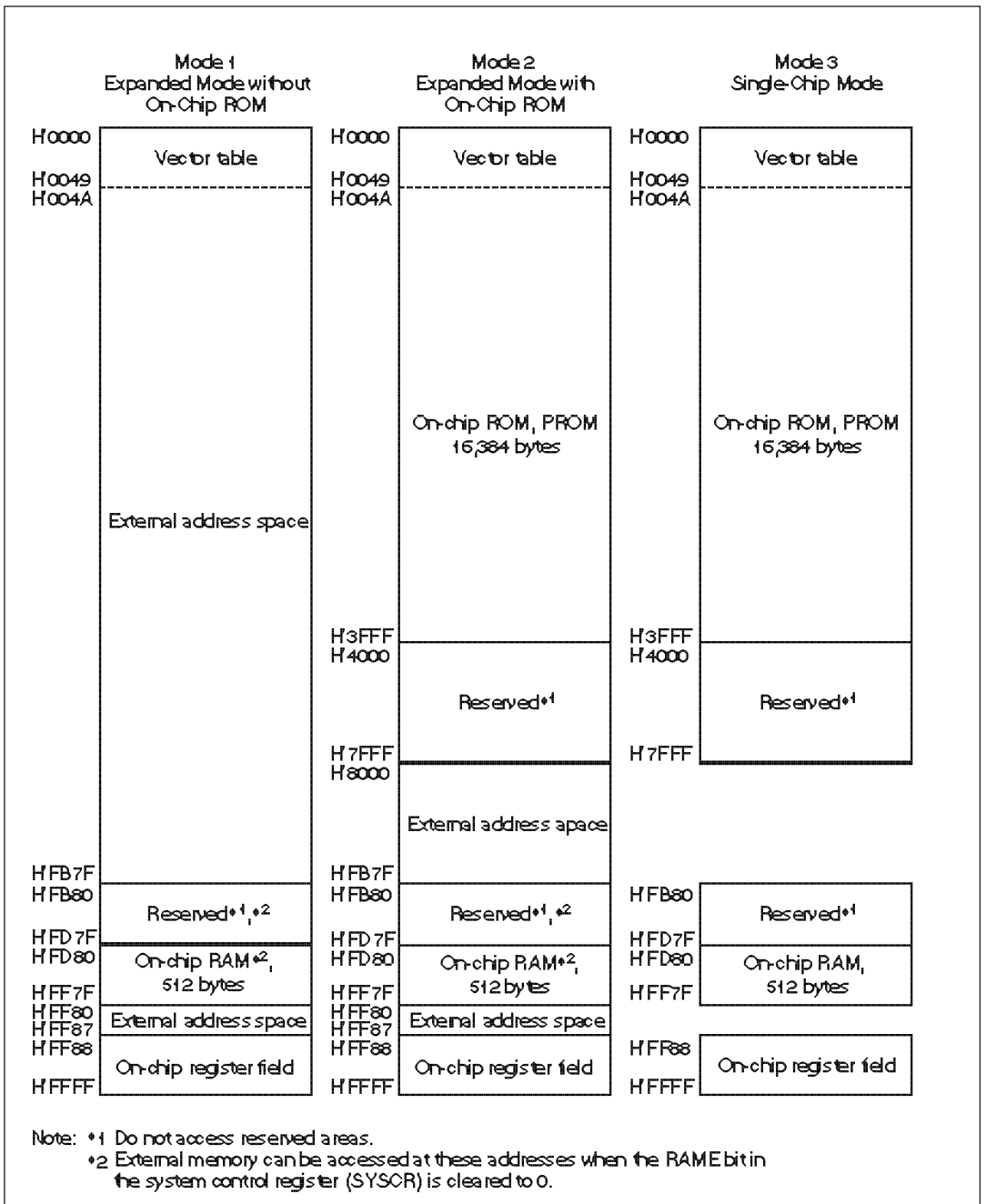

Figure 3-4 H8/3292 Address Space Map

Section 4 Exception Handling

4.1 Overview

The H8/3297 Series recognizes two kinds of exceptions: interrupts and the reset. Table 4-1 indicates their priority and the timing of their hardware exception-handling sequence.

Table 4-1 Hardware Exception-Handling Sequences and Priority

Priority	Type of Exception	Detection Timing	Timing of Exception-Handling Sequence
High	Reset	Synchronized with clock	The hardware exception-handling sequence begins as soon as $\overline{\text{RES}}$ changes from low to high.
Low	Interrupt	End of instruction execution*	When an interrupt is requested, the hardware exception-handling sequence begins at the end of the current instruction, or at the end of the current hardware exception-handling sequence.

Note: * Not detected after ANDC, ORC, XORC, and LDC instructions.

4.2 Reset

4.2.1 Overview

A reset has the highest exception-handling priority. When the $\overline{\text{RES}}$ pin goes low, or when there is a watchdog timer reset (when the reset option is selected for watchdog timer overflow), all current processing stops and the chip enters the reset state. The internal state of the CPU and the registers of the on-chip supporting modules are initialized. The reset exception-handling sequence starts when $\overline{\text{RES}}$ returns from low to high, or at the end of a watchdog reset pulse.

4.2.2 Reset Sequence

The reset state begins when $\overline{\text{RES}}$ goes low or a watchdog reset is generated. To ensure correct resetting, at power-on the $\overline{\text{RES}}$ pin should be held low for at least 20 ms. In a reset during operation, the $\overline{\text{RES}}$ pin should be held low for at least 10 system clock cycles. The watchdog reset pulse width is always 518 system clocks. For the pin states during a reset, see appendix D, Pin States.

The following sequence is carried out when reset exception handling begins.

- (1) The internal state of the CPU and the registers of the on-chip supporting modules are initialized, and the I bit in the condition code register (CCR) is set to 1.
- (2) The CPU loads the program counter with the first word in the vector table (stored at addresses H'0000 and H'0001) and starts program execution.

The $\overline{\text{RES}}$ pin should be held low when power is switched off, as well as when power is switched on.

Figure 4-1 indicates the timing of the reset sequence in modes 2 and 3. Figure 4-2 indicates the timing in mode 1.

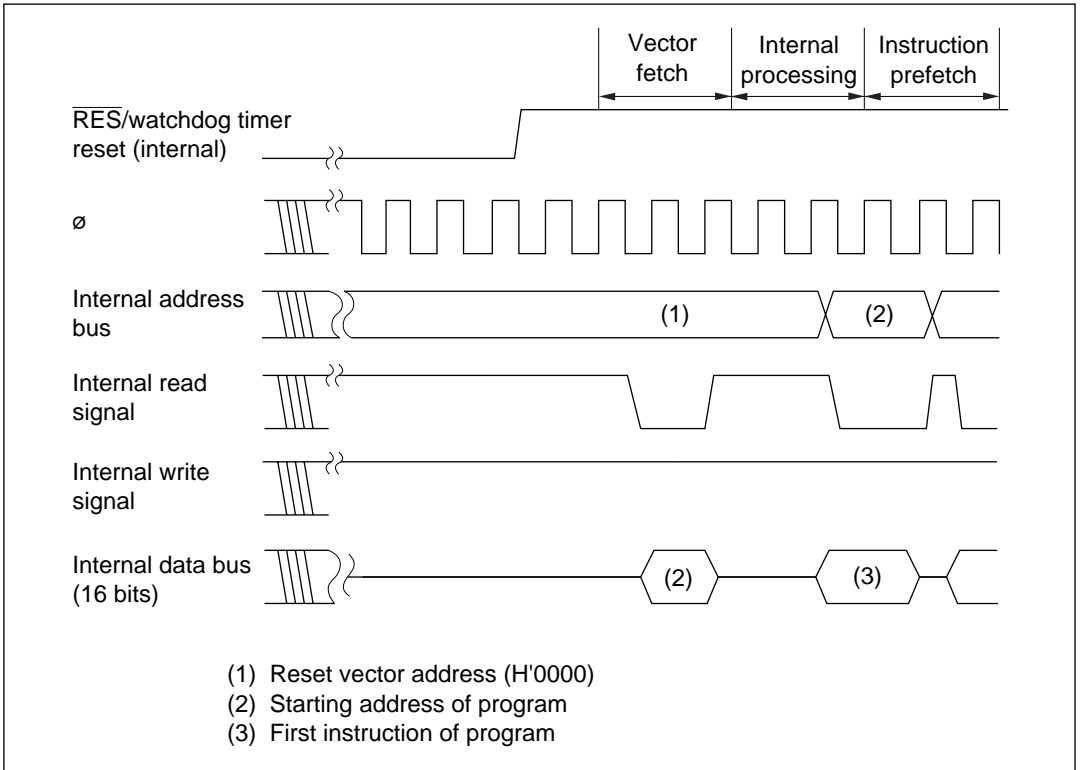
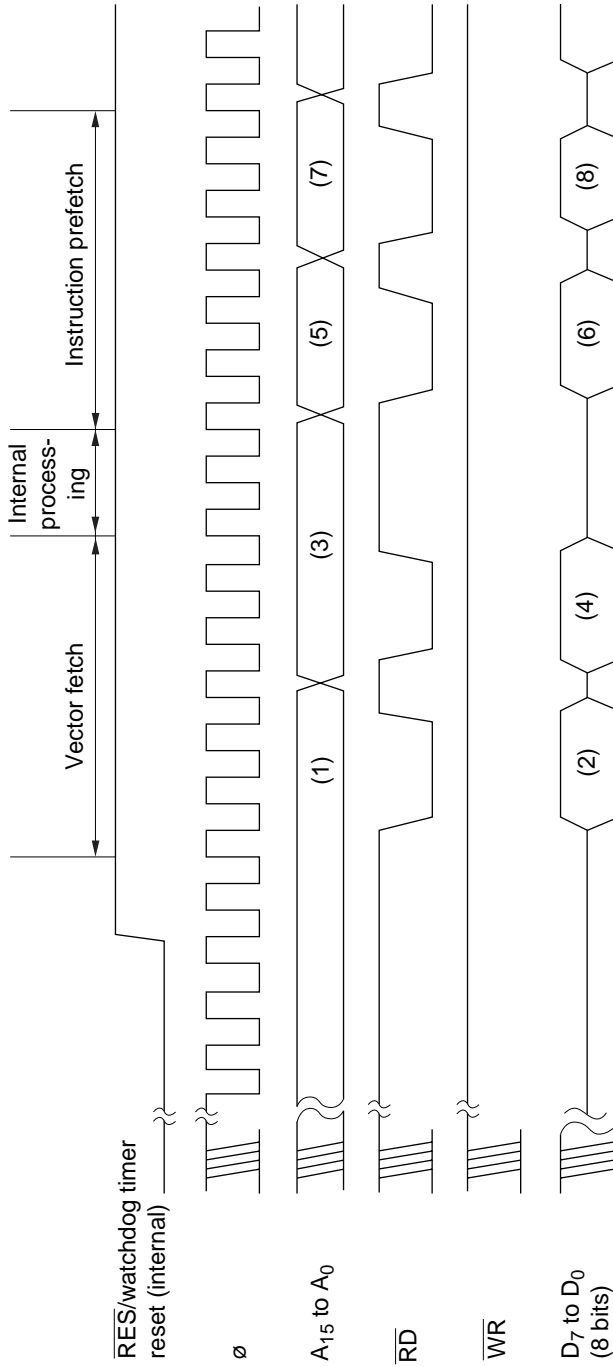

Figure 4-1 Reset Sequence (Mode 2 or 3, Program Stored in On-Chip ROM)



- (1), (3) Reset vector address: (1) = H'0000, (3) = H'0001
 (2), (4) Starting address of program (contents of reset vector): (2) = upper byte, (4) = lower byte
 (5), (7) Starting address of program: (5) = (2) (4), (7) = (2) (4) + 1
 (6), (8) First instruction of program: (6) = first byte, (8) = second byte

Figure 4-2 Reset Sequence (Mode 1)

4.2.3 Disabling of Interrupts after Reset

After a reset, if an interrupt were to be accepted before initialization of the stack pointer (SP: R7), the program counter and condition code register might not be saved correctly, leading to a program crash. To prevent this, all interrupts, including NMI, are disabled immediately after a reset. The first program instruction is therefore always executed. This instruction should initialize the stack pointer (example: MOV.W #xx:16, SP).

After reset exception handling, in order to initialize the contents of CCR, a CCR manipulation instruction can be executed before an instruction to initialize the stack pointer. Immediately after execution of a CCR manipulation instruction, all interrupts including NMI are disabled. Use the next instruction to initialize the stack pointer.

4.3 Interrupts

4.3.1 Overview

The interrupt sources include four external sources (NMI, and IRQ₀ to IRQ₂), and 19 internal sources in the on-chip supporting modules. Table 4-2 lists the interrupt sources in priority order and gives their vector addresses. When two or more interrupts are requested, the interrupt with highest priority is served first.

The features of these interrupts are:

- NMI has the highest priority and is always accepted. All internal and external interrupts except NMI can be masked by the I bit in the CCR. When the I bit is set to 1, interrupts other than NMI are not accepted.
- IRQ₀ to IRQ₂ can be sensed on the falling edge of the input signal, or level-sensed. The type of sensing can be selected for each interrupt individually. NMI is edge-sensed, and either the rising or falling edge can be selected.
- All interrupts are individually vectored. The software interrupt-handling routine does not have to determine what type of interrupt has occurred.
- The watchdog timer can generate either an NMI or overflow interrupt, depending on the needs of the application. For details, see section 10, Watchdog Timer.

Table 4-2 Interrupts

Interrupt source		No.	Vector Table Address	Priority
NMI		3	H'0006 to H'0007	High ↑
IRQ0		4	H'0008 to H'0009	
IRQ1		5	H'000A to H'000B	
IRQ2		6	H'000C to H'000D	
Reserved		7	H'000E to H'000F	
		8	H'0010 to H'0011	
		9	H'0012 to H'0013	
		10	H'0014 to H'0015	
		11	H'0016 to H'0017	
16-bit free-running timer	ICIA (Input capture A)	12	H'0018 to H'0019	
	ICIB (Input capture B)	13	H'001A to H'001B	
	ICIC (Input capture C)	14	H'001C to H'001D	
	ICID (Input capture D)	15	H'001E to H'001F	
	OCIA (Output compare A)	16	H'0020 to H'0021	
	OCIB (Output compare B)	17	H'0022 to H'0023	
	FOV1 (Overflow)	18	H'0024 to H'0025	
8-bit timer 0	CMI0A (Compare-match A)	19	H'0026 to H'0027	
	CMI0B (Compare-match B)	20	H'0028 to H'0029	
	OVI0 (Overflow)	21	H'002A to H'002B	
8-bit timer 1	CMI1A (Compare-match A)	22	H'002C to H'002D	
	CMI1B (Compare-match B)	23	H'002E to H'002F	
	OVI1 (Overflow)	24	H'0030 to H'0031	
Reserved		25	H'0032 to H'0033	
		26	H'0034 to H'0035	
Serial communication interface	ERI (Receive error)	27	H'0036 to H'0037	
	RXI (Receive end)	28	H'0038 to H'0039	
	TXI (TDR empty)	29	H'003A to H'003B	
	TEI (TSR empty)	30	H'003C to H'003D	
Reserved		31	H'003E to H'003F	
		32	H'0040 to H'0041	
		33	H'0042 to H'0043	
		34	H'0044 to H'0045	
A/D converter	ADI (Conversion end)	35	H'0046 to H'0047	Low ↓
Watchdog timer	WOVF (WDT overflow)	36	H'0048 to H'0049	

Notes: 1. H'0000 and H'0001 contain the reset vector.

2. H'0002 to H'0005 are reserved in the H8/3297 Series and are not available to the user.

4.3.2 Interrupt-Related Registers

The interrupt-related registers are the system control register (SYSCR), IRQ sense control register (ISCR), and IRQ enable register (IER).

Table 4-3 Registers Read by Interrupt Controller

Name	Abbreviation	Read/write	Address
System control register	SYSCR	R/W	H'FFC4
IRQ sense control register	ISCR	R/W	H'FFC6
IRQ enable register	IER	R/W	H'FFC7

System Control Register (SYSCR)

Bit	7	6	5	4	3	2	1	0
	SSBY	STS2	STS1	STS0	XRST	NMIEG	—	RAME
Initial value	0	0	0	0	1	0	1	1
Read/Write	R/W	R/W	R/W	R/W	R	R/W	—	R/W

The valid edge on the $\overline{\text{NMI}}$ line is controlled by bit 2 (NMIEG) in the system control register.

Bit 2—NMI Edge (NMIEG): Determines whether a nonmaskable interrupt is generated on the falling or rising edge of the $\overline{\text{NMI}}$ input signal.

Bit 2

NMIEG	Description
0	An interrupt is generated on the falling edge of $\overline{\text{NMI}}$. (Initial state)
1	An interrupt is generated on the rising edge of $\overline{\text{NMI}}$.

See section 3.2, System Control Register, for information on the other SYSCR bits.

IRQ Sense Control Register (ISCR)—H'FFC6

Bit	7	6	5	4	3	2	1	0
	—	—	—	—	—	IRQ2SC	IRQ1SC	IRQ0SC
Initial value	1	1	1	1	1	0	0	0
Read/Write	—	—	—	—	—	R/W	R/W	R/W

Bits 7 to 3—Reserved: These bits cannot be modified and are always read as 1

Bits 2 to 0—IRQ₂ to IRQ₀ Sense Control (IRQ2SC to IRQ0SC): These bits determine whether $\overline{\text{IRQ}}_2$ to $\overline{\text{IRQ}}_0$ are level-sensed or sensed on the falling edge.

Bits 2 to 0

IRQ2SC to IRQ0SC	Description
0	An interrupt is generated when $\overline{\text{IRQ}}_2$ to $\overline{\text{IRQ}}_0$ inputs are low. (Initial state)
1	An interrupt is generated by the falling edge of the $\overline{\text{IRQ}}_2$ to $\overline{\text{IRQ}}_0$ inputs.

IRQ Enable Register (IER)

Bit	7	6	5	4	3	2	1	0
	—	—	—	—	—	IRQ2E	IRQ1E	IRQ0E
Initial value	1	1	1	1	1	0	0	0
Read/Write	—	—	—	—	—	R/W	R/W	R/W

Bits 7 to 3—Reserved: These bits cannot be modified and are always read as 1

Bits 2 to 0—IRQ₂ to IRQ₀ Enable (IRQ2E to IRQ0E): These bits enable or disable the $\overline{\text{IRQ}}_2$ to $\overline{\text{IRQ}}_0$ interrupts individually.

Bits 2 to 0

IRQ2E to IRQ0E	Description
0	$\overline{\text{IRQ}}_2$ to $\overline{\text{IRQ}}_0$ interrupt requests are disabled. (Initial state)
1	$\overline{\text{IRQ}}_2$ to $\overline{\text{IRQ}}_0$ interrupt requests are enabled.

When edge sensing is selected (by setting bits IRQ2SC to IRQ0SC to 1), it is possible for an interrupt-handling routine to be executed even though the corresponding enable bit (IRQ2E to IRQ0E) is cleared to 0 and the interrupt is disabled. If an interrupt is requested while the enable bit (IRQ2E to IRQ0E) is set to 1, the request will be held pending until served. If the enable bit is cleared to 0 while the request is still pending, the request will remain pending, although new requests will not be recognized. If the interrupt mask bit (I) in the CCR is cleared to 0, the interrupt-handling routine can be executed even though the enable bit is now 0.

If execution of interrupt-handling routines under these conditions is not desired, it can be avoided by using the following procedure to disable and clear interrupt requests.

1. Set the I bit to 1 in the CCR, masking interrupts. Note that the I bit is set to 1 automatically when execution jumps to an interrupt vector.
2. Clear the desired bits from IRQ2E to IRQ0E to 0 to disable new interrupt requests.
3. Clear the corresponding IRQ2SC to IRQ0SC bits to 0, then set them to 1 again. Pending IRQn interrupt requests are cleared when I = 1 in the CCR, IRQnSC = 0, and IRQnE = 0.

4.3.3 External Interrupts

The four external interrupts are NMI and IRQ_2 to IRQ_0 . These four interrupts can be used to recover from software standby mode.

(1) NMI: A nonmaskable interrupt is generated on the rising or falling edge of the \overline{NMI} input signal regardless of whether the I (interrupt mask) bit is set in the CCR. The valid edge is selected by the NMIEG bit in the system control register. The NMI vector number is 3. In the NMI hardware exception-handling sequence the I bit in the CCR is set to 1.

(2) IRQ_2 to IRQ_0 : These interrupt signals are level-sensed or sensed on the falling edge of the input, as selected by ISCR bits $IRQ2SC$ to $IRQ0SC$. These interrupts can be masked collectively by the I bit in the CCR, and can be enabled and disabled individually by setting and clearing bits $IRQ2E$ to $IRQ0E$ in the IRQ enable register.

When one of these interrupts is accepted, the I bit is set to 1. IRQ_2 to IRQ_0 have interrupt vector numbers 4 to 6. They are prioritized in order from IRQ_2 (low) to IRQ_0 (high). For details, see table 4-2.

Interrupts IRQ_2 to IRQ_0 do not depend on whether pins $\overline{IRQ_2}$ to $\overline{IRQ_0}$ are input or output pins. When using external interrupts IRQ_2 to IRQ_0 , clear the corresponding DDR bits to 0 to set these pins to the input state, and do not use these pins as input or output pins for the timers, serial communication interface, or A/D converter.

4.3.4 Internal Interrupts

Nineteen internal interrupts can be requested by the on-chip supporting modules. Each interrupt source has its own vector number, so the interrupt-handling routine does not have to determine which interrupt has occurred. All internal interrupts are masked when the I bit in the CCR is set to 1. When one of these interrupts is accepted, the I bit is set to 1 to mask further interrupts (except \overline{NMI}). The vector numbers are 12 to 36. For the priority order, see table 4-2.

4.3.5 Interrupt Handling

Interrupts are controlled by an interrupt controller that arbitrates between simultaneous interrupt requests, commands the CPU to start the hardware interrupt exception-handling sequence, and furnishes the necessary vector number. Figure 4-3 shows a block diagram of the interrupt controller.

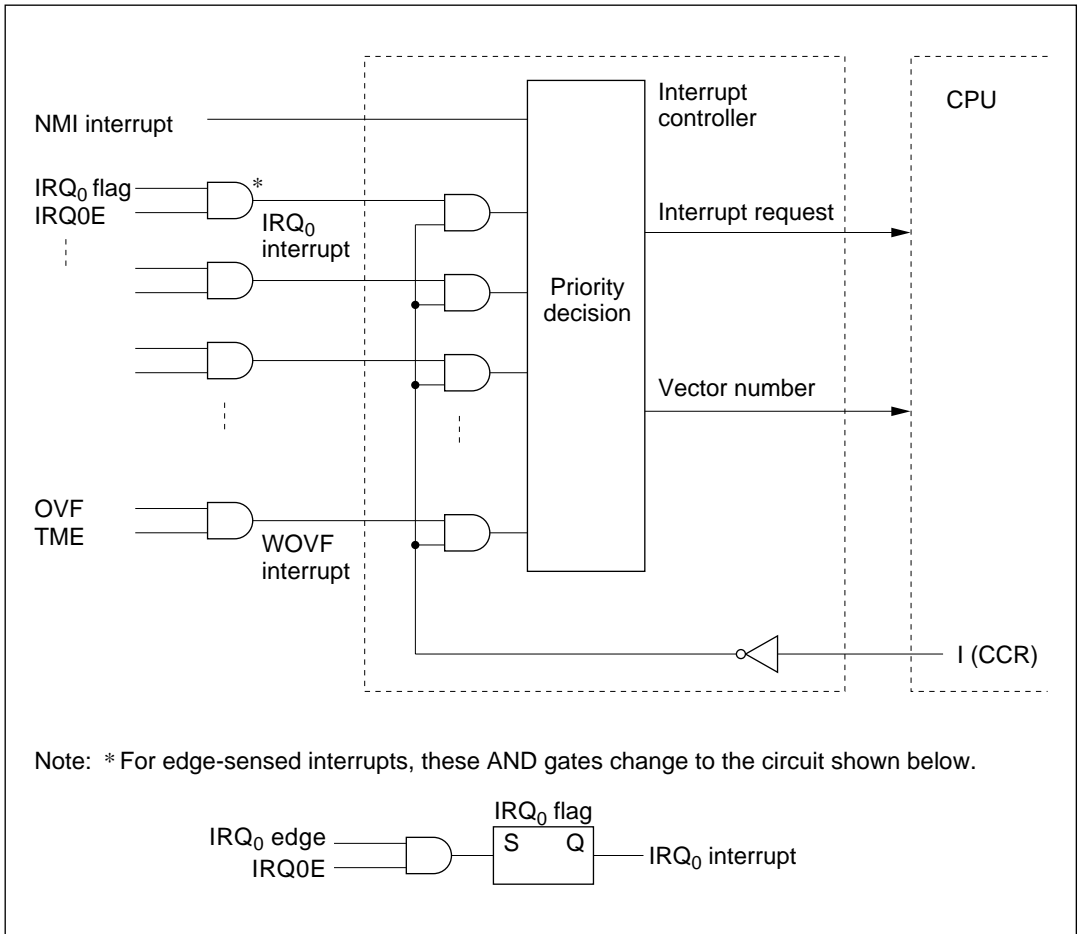

Figure 4-3 Block Diagram of Interrupt Controller

The IRQ interrupts and interrupts from the on-chip supporting modules (except for reset selected for a watchdog timer overflow) all have corresponding enable bits. When the enable bit is cleared to 0, the interrupt signal is not sent to the interrupt controller, so the interrupt is ignored. These interrupts can also all be masked by setting the CPU's interrupt mask bit (I) to 1. Accordingly, these interrupts are accepted only when their enable bit is set to 1 and the I bit is cleared to 0.

The nonmaskable interrupt (NMI) is always accepted, except in the reset state and hardware standby mode.

When an NMI or another enabled interrupt is requested, the interrupt controller transfers the interrupt request to the CPU and indicates the corresponding vector number. (When two or more interrupts are requested, the interrupt controller selects the vector number of the interrupt with the highest priority.) When notified of an interrupt request, at the end of the current instruction or current hardware exception-handling sequence, the CPU starts the hardware exception-handling sequence for the interrupt and latches the vector number.

Figure 4-4 is a flowchart of the interrupt (and reset) operations. Figure 4-6 shows the interrupt timing sequence for the case in which the software interrupt-handling routine is in on-chip ROM and the stack is in on-chip RAM.

- (1) An interrupt request is sent to the interrupt controller when an NMI interrupt occurs, and when an interrupt occurs on an IRQ input line or in an on-chip supporting module provided the enable bit of that interrupt is set to 1.
- (2) The interrupt controller checks the I bit in CCR and accepts the interrupt request if the I bit is cleared to 0. If the I bit is set to 1 only NMI requests are accepted; other interrupt requests remain pending.
- (3) Among all accepted interrupt requests, the interrupt controller selects the request with the highest priority and passes it to the CPU. Other interrupt requests remain pending.
- (4) When it receives the interrupt request, the CPU waits until completion of the current instruction or hardware exception-handling sequence, then starts the hardware exception-handling sequence for the interrupt and latches the interrupt vector number.
- (5) In the hardware exception-handling sequence, the CPU first pushes the PC and CCR onto the stack. See figure 4-5. The stacked PC indicates the address of the first instruction that will be executed on return from the software interrupt-handling routine.
- (6) Next the I bit in CCR is set to 1, masking all further interrupts except NMI.
- (7) The vector address corresponding to the vector number is generated, the vector table entry at this vector address is loaded into the program counter, and execution branches to the software interrupt-handling routine at the address indicated by that entry.

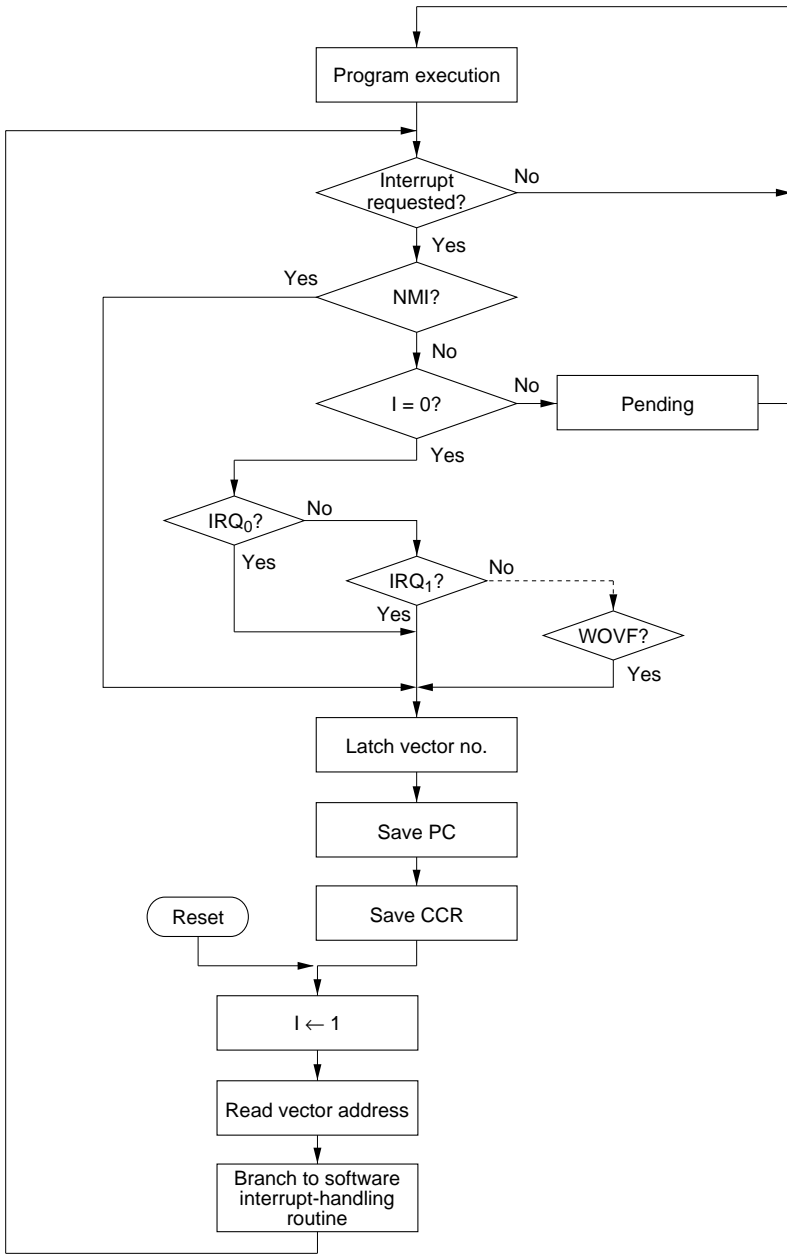

Figure 4-4 Hardware Interrupt-Handling Sequence

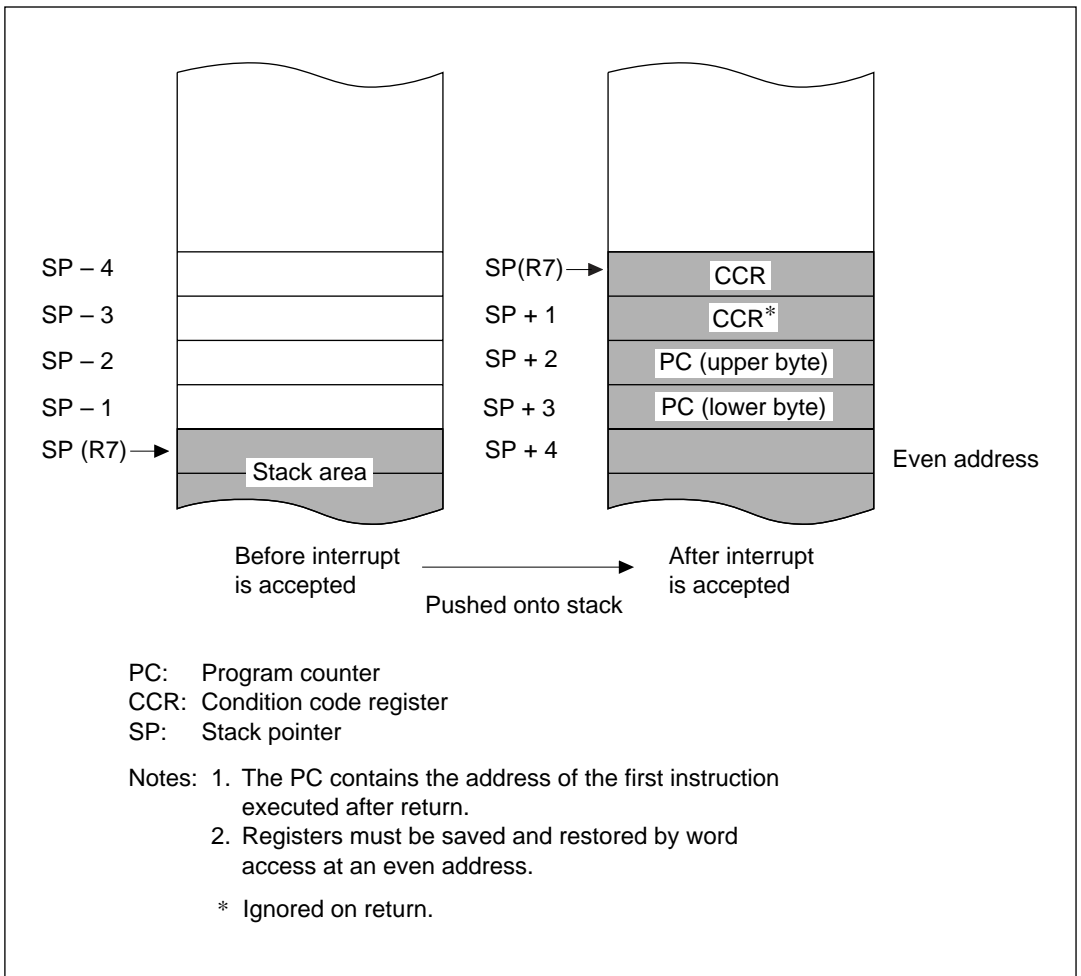
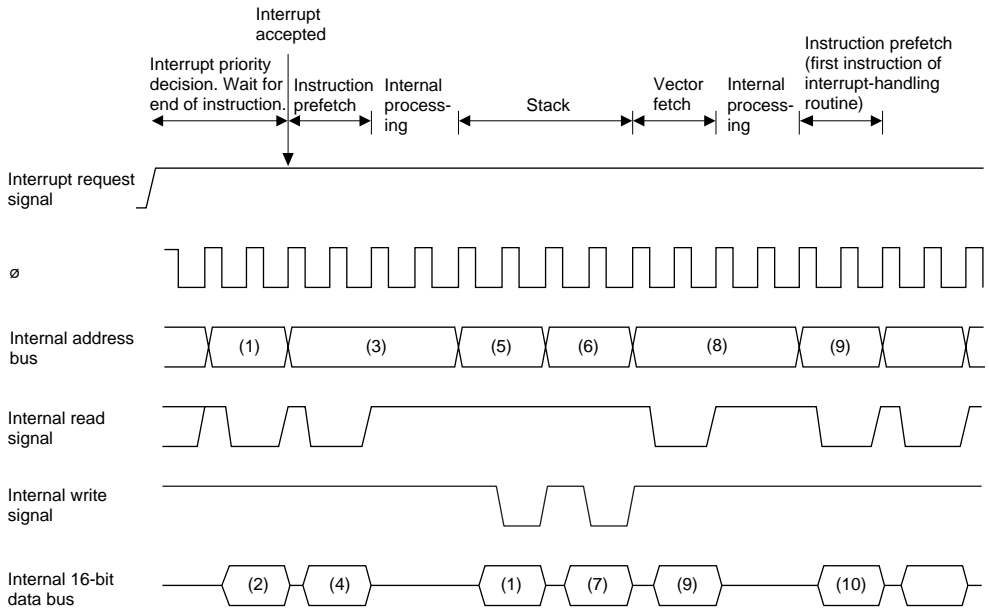

Figure 4-5 Usage of Stack in Interrupt Handling

The CCR is comprised of one byte, but when it is saved to the stack, it is treated as one word of data. During interrupt processing, two identical bytes of CCR data are saved to the stack to create one word of data. When the RTE instruction is executed to restore the value from the stack, the byte located at the even address is loaded into CCR, and the byte located at the odd address is ignored.



- (1) Instruction prefetch address (Pushed on stack. Instruction is executed on return from interrupt-handling routine.)
- (2) (4) Instruction code (Not executed)
- (3) Instruction prefetch address (Not executed)
- (5) SP-2
- (6) SP-4
- (7) CCR
- (8) Address of vector table entry
- (9) Vector table entry (address of first instruction of interrupt-handling routine)
- (10) First instruction of interrupt-handling routine

Figure 4-6 Timing of Interrupt Sequence

4.3.6 Interrupt Response Time

Table 4-4 indicates the number of states that elapse from an interrupt request signal until the first instruction of the software interrupt-handling routine is executed. Since on-chip memory is accessed 16 bits at a time, very fast interrupt service can be obtained by placing interrupt-handling routines in on-chip ROM and the stack in on-chip RAM.

Table 4-4 Number of States before Interrupt Service

No.	Reason for Wait	Number of States	
		On-Chip Memory	External Memory
1	Interrupt priority decision	2*3	2*3
2	Wait for completion of current instruction*1	1 to 13	5 to 17*2
3	Save PC and CCR	4	12*2
4	Fetch vector	2	6*2
5	Fetch instruction	4	12*2
6	Internal processing	4	4
Total		17 to 29	41 to 53 *2

- Notes: 1. These values do not apply if the current instruction is EEPMOV.
2. If wait states are inserted in external memory access, add the number of wait states.
3. 1 for internal interrupts.

4.3.7 Precaution

Note that the following type of contention can occur in interrupt handling.

When software clears the enable bit of an interrupt to 0 to disable the interrupt, the interrupt becomes disabled after execution of the clearing instruction. If an enable bit is cleared by a BCLR or MOV instruction, for example, and the interrupt is requested during execution of that instruction, at the instant when the instruction ends the interrupt is still enabled, so after execution of the instruction, the hardware exception-handling sequence is executed for the interrupt. If a higher-priority interrupt is requested at the same time, however, the hardware exception-handling sequence is executed for the higher-priority interrupt and the interrupt that was disabled is ignored.

Similar considerations apply when an interrupt request flag is cleared to 0.

Figure 4-7 shows an example in which the OCIAE bit is cleared to 0.

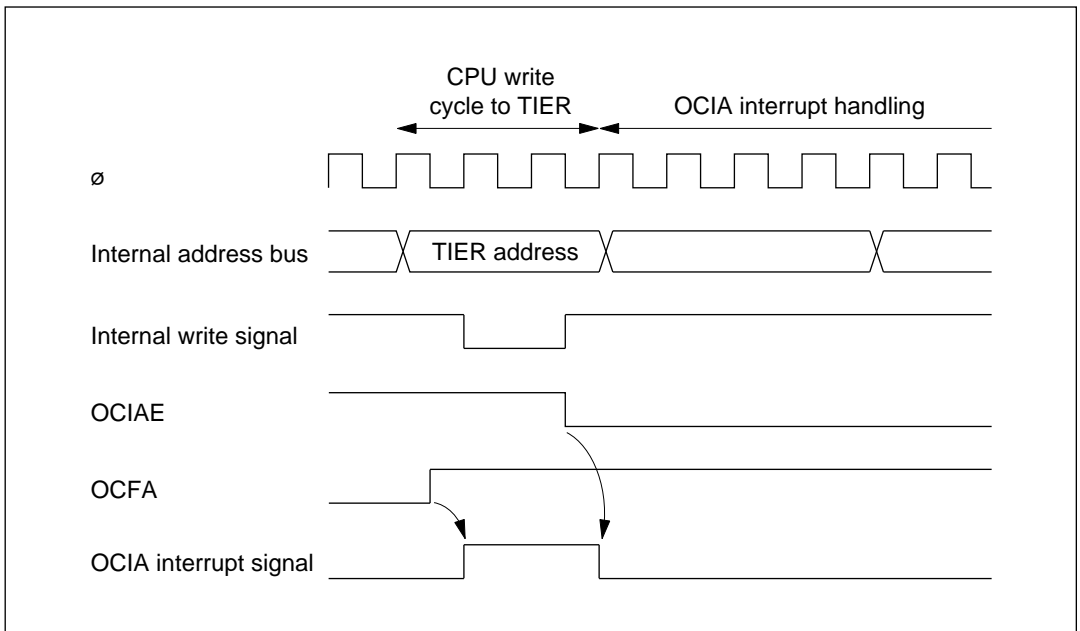

Figure 4-7 Contention between Interrupt and Disabling Instruction

The above contention does not occur if the enable bit or flag is cleared to 0 while the interrupt mask bit (I) is set to 1.

4.4 Note on Stack Handling

In word access, the least significant bit of the address is always assumed to be 0. The stack is always accessed by word access. Care should be taken to keep an even value in the stack pointer (general register R7). Use the PUSH and POP (or MOV.W Rn, @-SP and MOV.W @SP+, Rn) instructions to push and pop registers on the stack.

Setting the stack pointer to an odd value can cause programs to crash. Figure 4-8 shows an example of damage caused when the stack pointer contains an odd address.

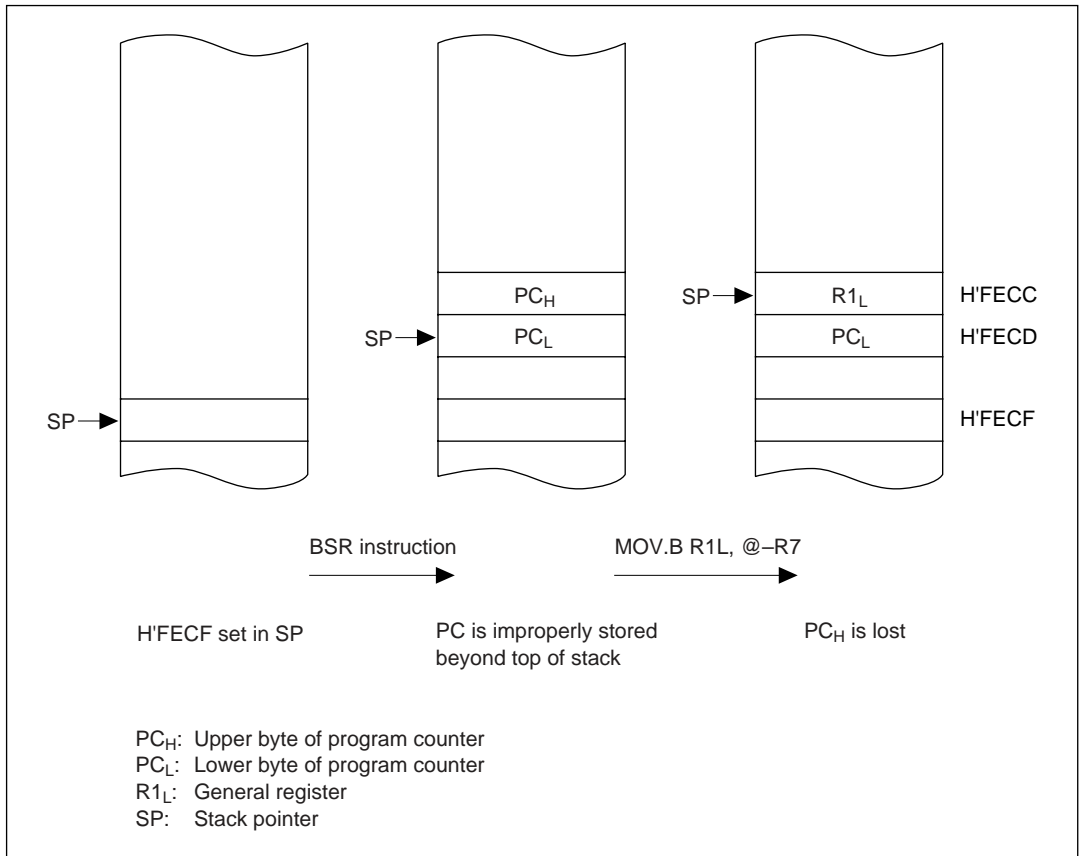

Figure 4-8 Example of Damage Caused by Setting an Odd Address in R7

Section 5 Wait-State Controller

5.1 Overview

The H8/3297 Series has an on-chip wait-state controller that enables insertion of wait states into bus cycles for interfacing to low-speed external devices.

5.1.1 Features

Features of the wait-state controller are listed below.

- Three selectable wait modes: programmable wait mode, pin auto-wait mode, and pin wait mode
- Automatic insertion of zero to three wait states

5.1.2 Block Diagram

Figure 5-1 shows a block diagram of the wait-state controller.

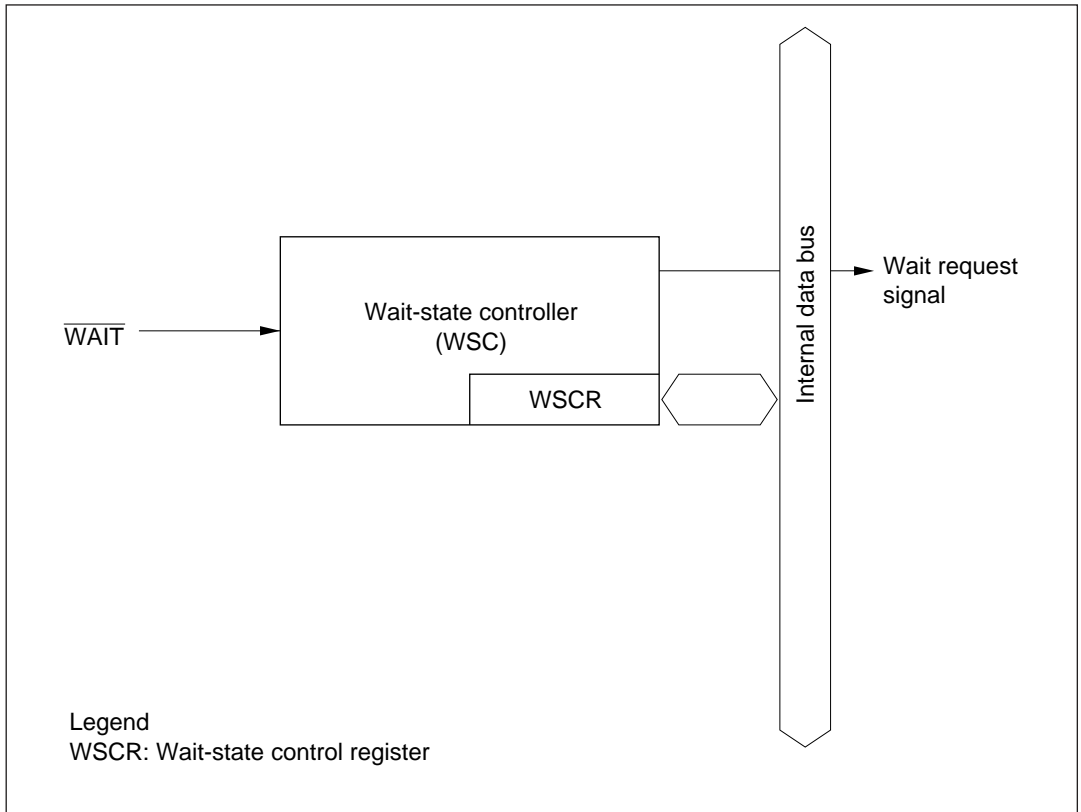

Figure 5-1 Block Diagram of Wait-State Controller

5.1.3 Input/Output Pins

Table 5-1 summarizes the wait-state controller's input pin.

Table 5-1 Wait-State Controller Pins

Name	Abbreviation	I/O	Function
Wait	WAIT	Input	Wait request signal for access to external addresses

5.1.4 Register Configuration

Table 5-2 summarizes the wait-state controller's register.

Table 5-2 Register Configuration

Address	Name	Abbreviation	R/W	Initial Value
H'FFC2	Wait-state control register	WSCR	R/W	H'08

5.2 Register Description

5.2.1 Wait-State Control Register (WSCR)

WSCR is an 8-bit readable/writable register that selects the wait mode for the wait-state controller (WSC) and specifies the number of wait states. It also controls frequency division of the clock signals supplied to the supporting modules.

Bit	7	6	5	4	3	2	1	0
	—	—	CKDBL	—	WMS1	WMS0	WC1	WC0
Initial value	0	0	0	0	1	0	0	0
Read/Write	R/W	R/W	R/W	R/W	R/W	R/W	R/W	R/W

WSCR is initialized to H'08 by a reset and in hardware standby mode. It is not initialized in software standby mode.

Bits 7 and 6—Reserved

Bit 5—Clock Double (CKDBL): Controls frequency division of clock signals supplied to supporting modules. For details, see section 6, Clock Pulse Generator.

Bit 4—Reserved: This bit is reserved, but it can be written and read. Its initial value is 0.

Bits 3 and 2—Wait Mode Select 1 and 0 (WMS1/0): These bits select the wait mode.

Bit 3 WMS1	Bit 2 WMS0	Description
0	0	Programmable wait mode
	1	No wait states inserted by wait-state controller
1	0	Pin wait mode (Initial value)
	1	Pin auto-wait mode

Bits 1 and 0—Wait Count 1 and 0 (WC1/0): These bits select the number of wait states inserted in access to external address areas.

Bit 1 WC1	Bit 0 WC0	Description
0	0	No wait states inserted by wait-state controller (Initial value)
	1	1 state inserted
1	0	2 states inserted
	1	3 states inserted

5.3 Wait Modes

Analog power supply: Analog power supply pin for the A/D converter. If the A/D converter is not used, connect AV_{CC} to the system power supply (V_{CC}). Figure 5-2 shows the timing when the wait count is 1 ($WC = 0, WC0 = 1$).

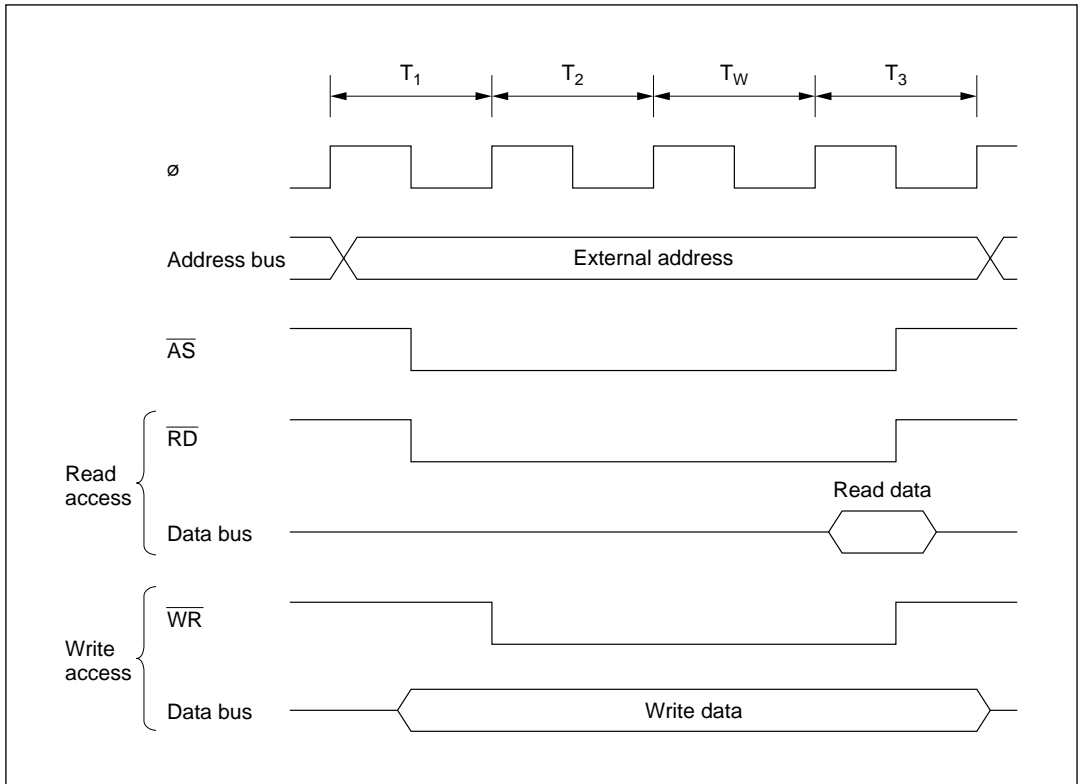

Figure 5-2 Programmable Wait Mode

Pin Wait Mode: In all accesses to external addresses, the number of wait states (T_W) selected by bits WC1 and WC0 are inserted. If the $\overline{\text{WAIT}}$ pin is low at the fall of the system clock (ϕ) in the last of these wait states, an additional wait state is inserted. If the $\overline{\text{WAIT}}$ pin remains low, wait states continue to be inserted until the $\overline{\text{WAIT}}$ signal goes high.

Pin wait mode is useful for inserting four or more wait states, or for inserting different numbers of wait states for different external devices.

Figure 5-3 shows the timing when the wait count is 1 ($\text{WC1} = 0, \text{WC0} = 1$) and one additional wait state is inserted by $\overline{\text{WAIT}}$ input.

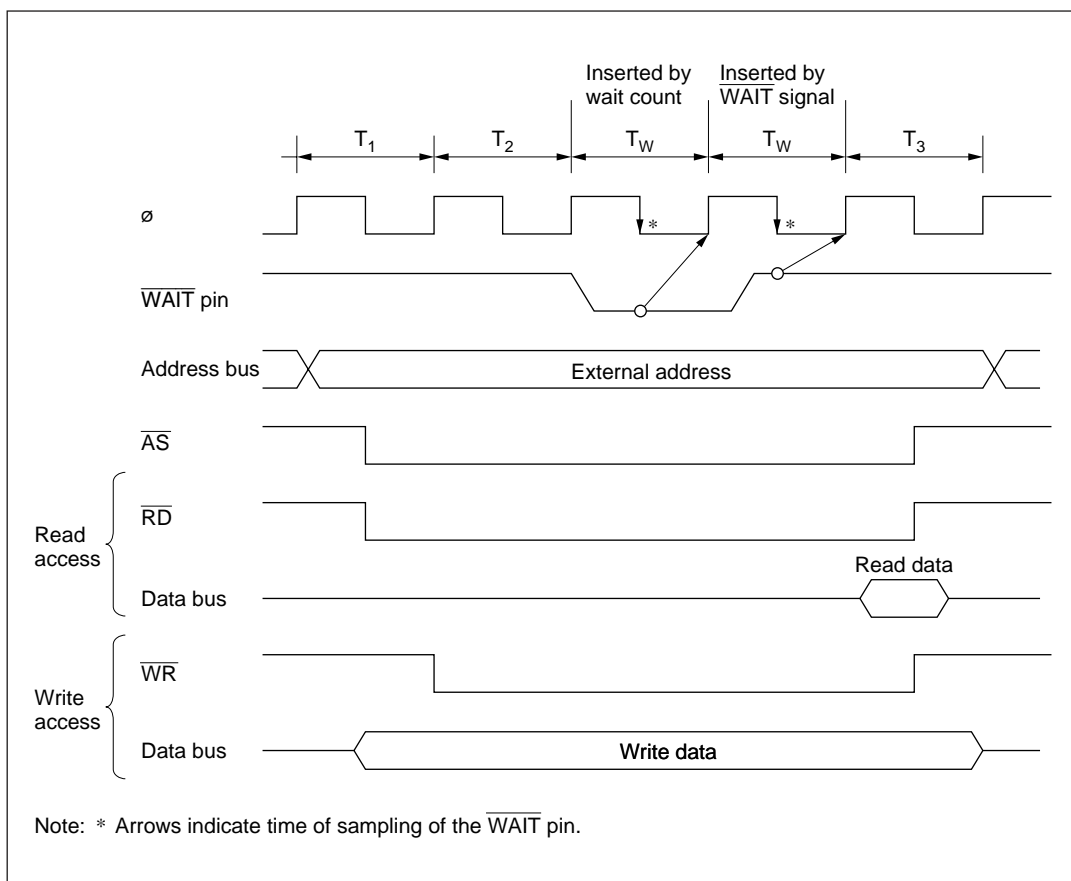

Figure 5-3 Pin Wait Mode

Pin Auto-Wait Mode: If the $\overline{\text{WAIT}}$ pin is low, the number of wait states (T_W) selected by bits WC1 and WC0 are inserted.

In pin auto-wait mode, if the $\overline{\text{WAIT}}$ pin is low at the fall of the system clock (ϕ) in the T_2 state, the number of wait states (T_W) selected by bits WC1 and WC0 are inserted. No additional wait states are inserted even if the $\overline{\text{WAIT}}$ pin remains low. Pin auto-wait mode can be used for an easy interface to low-speed memory, simply by routing the chip select signal to the $\overline{\text{WAIT}}$ pin.

Figure 5-4 shows the timing when the wait count is 1.

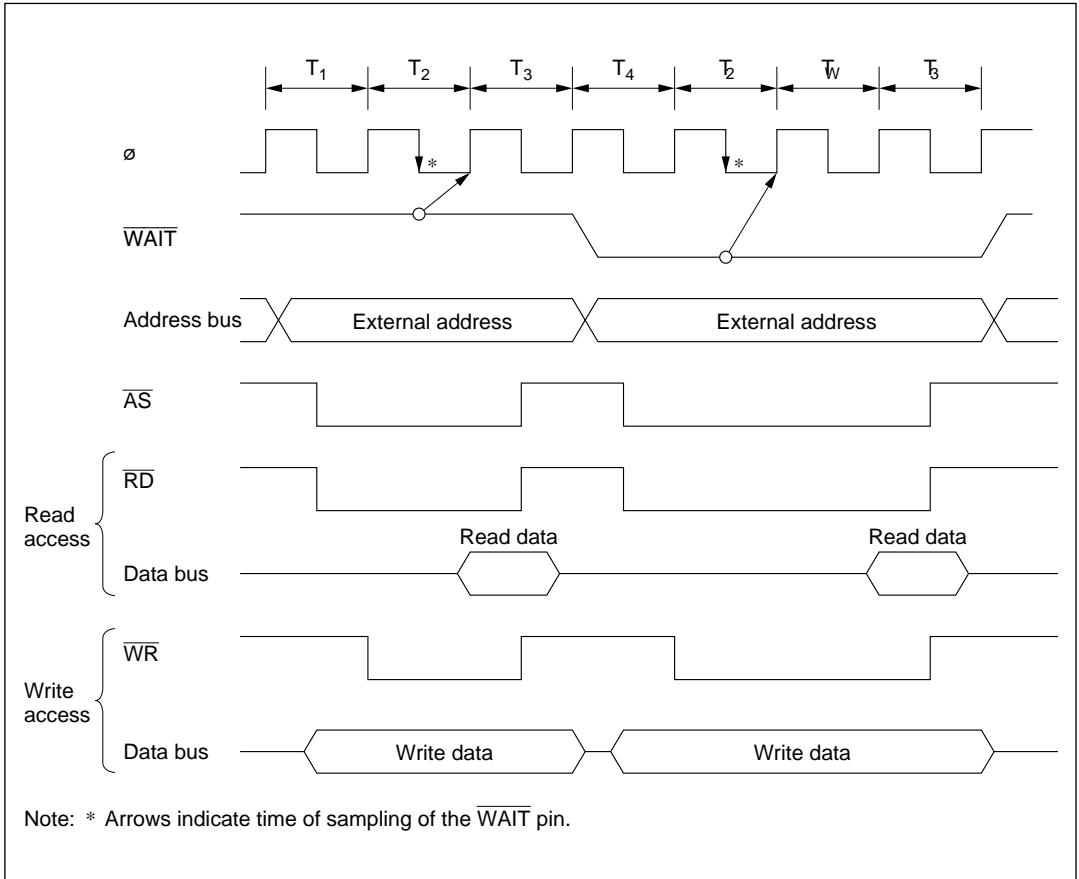

Figure 5-4 Pin Auto-Wait Mode

Section 6 Clock Pulse Generator

6.1 Overview

The H8/3297 Series has a built-in clock pulse generator (CPG) consisting of an oscillator circuit, a duty adjustment circuit, and a divider and a prescaler that generates clock signals for the on-chip supporting modules.

6.1.1 Block Diagram

Figure 6-1 shows a block diagram of the clock pulse generator.

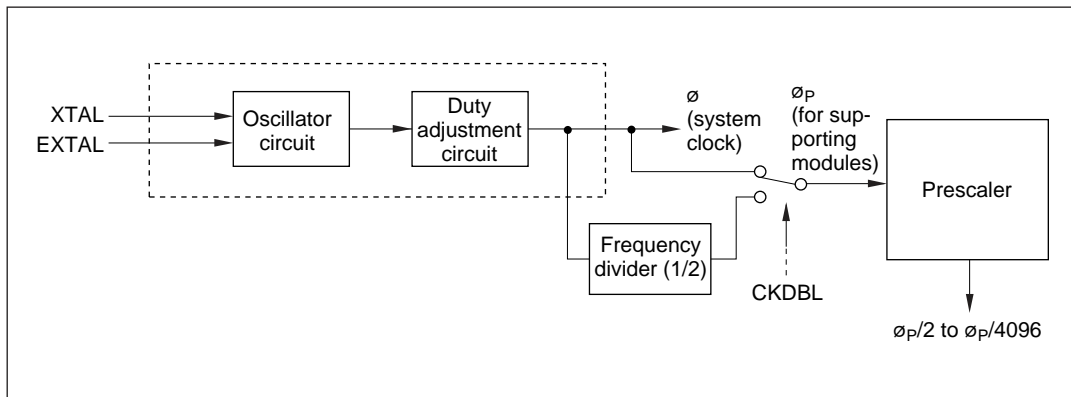

Figure 6-1 Block Diagram of Clock Pulse Generator

Input an external clock signal to the EXTAL pin, or connect a crystal resonator to the XTAL and EXTAL pins. The system clock frequency (ϕ) will be the same as the input frequency. This same system clock frequency (ϕ_P) can be supplied to timers and other supporting modules, or it can be divided by two. The selection is made by software, by controlling the CKDBL bit.

6.1.2 Wait-State Control Register (WSCR)

WSCR is an 8-bit readable/writable register that controls frequency division of the clock signals supplied to the supporting modules. It also controls wait-state insertion.

WSCR is initialized to H'08 by a reset and in hardware standby mode. It is not initialized in software standby mode.

Bit	7	6	5	4	3	2	1	0
	—	—	CKDBL	—	WMS1	WMS0	WC1	WC0
Initial value	0	0	0	0	1	0	0	0
Read/Write	R/W	R/W	R/W	R/W	R/W	R/W	R/W	R/W

Bits 7 and 6—Reserved

Bit 5—Clock Double (CKDBL): Controls the frequency division of clock signals supplied to supporting modules.

Bit 5

CKDBL Description

0	The undivided system clock (ϕ) is supplied as the clock (ϕ_P) for supporting modules. (Initial value)
1	The system clock (ϕ) is divided by two and supplied as the clock (ϕ_P) for supporting modules.

Bit 4—Reserved: This bit is reserved, but it can be written and read. Its initial value is 0.

Bits 3 and 2—Wait Mode Select 1 and 0 (WMS1/0)

Bits 1 and 0—Wait Count 1 and 0 (WC1/0)

These bits control wait-state insertion. For details, see section 5, Wait-State Controller.

6.2 Oscillator Circuit

If an external crystal is connected across the EXTAL and XTAL pins, the on-chip oscillator circuit generates a system clock signal. Alternatively, an external clock signal can be applied to the EXTAL pin.

(1) Connecting an External Crystal

① **Circuit Configuration:** An external crystal can be connected as in the example in figure 6-2. Table 6-1 indicates the appropriate damping resistance R_d . An AT-cut parallel resonance crystal should be used.

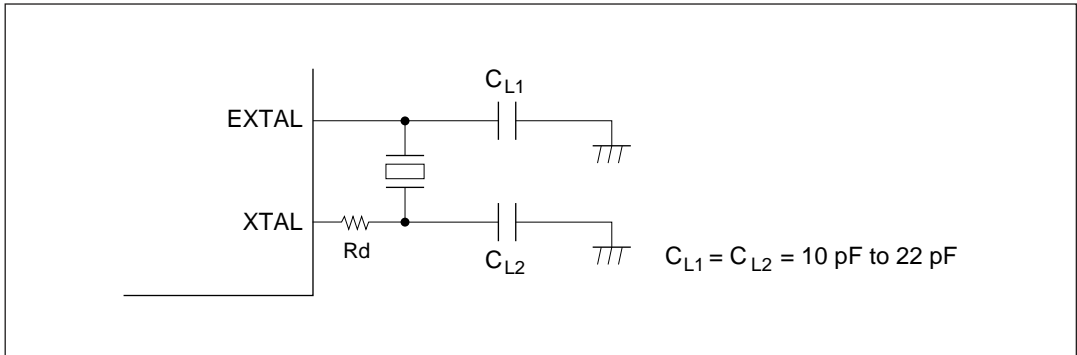

Figure 6-2 Connection of Crystal Oscillator (Example)

Table 6-1 Damping Resistance

Frequency (MHz)	2	4	8	12	16
R_d max (Ω)	1 k	500	200	0	0

② **Crystal Oscillator:** Figure 6-3 shows an equivalent circuit of the crystal resonator. The crystal resonator should have the characteristics listed in table 6-2.

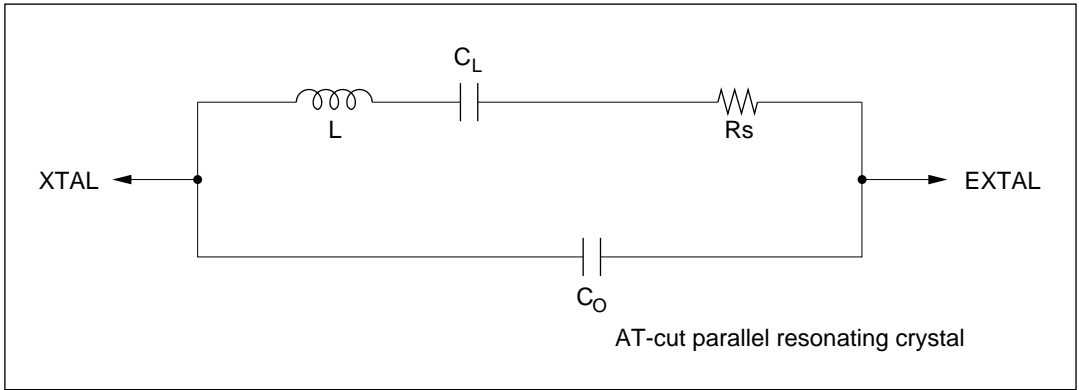

Figure 6-3 Equivalent Circuit of External Crystal

Table 6-2 External Crystal Parameters

Frequency (MHz)	2	4	8	12	16
R _s max (Ω)	500	120	80	60	50
C ₀ (pF)	7 pF max				

Use a crystal with the same frequency as the desired system clock frequency (ϕ).

③ **Note on Board Design:** When an external crystal is connected, other signal lines should be kept away from the crystal circuit to prevent induction from interfering with correct oscillation. See figure 6-4. The crystal and its load capacitors should be placed as close as possible to the XTAL and EXTAL pins.

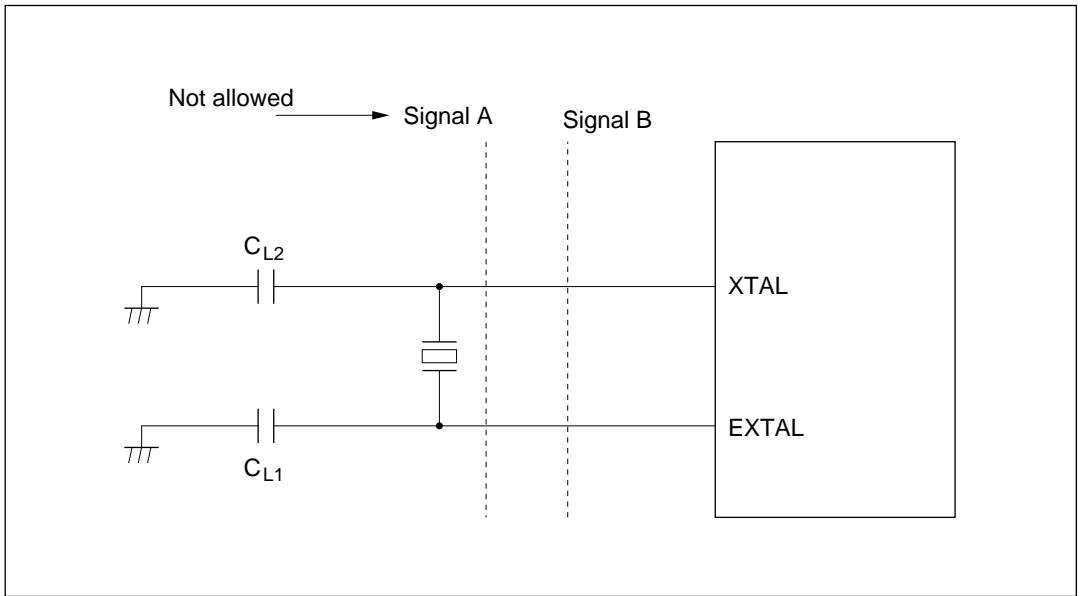

Figure 6-4 Notes on Board Design around External Crystal

(2) Input of External Clock Signal

① **Circuit Configuration:** An external clock signal can be input as shown in the examples in figure 6-5. In example (b) in figure 6-5, the external clock signal should be kept high during standby.

If the XTAL pin is left open, make sure the stray capacitance does not exceed 10 pF.

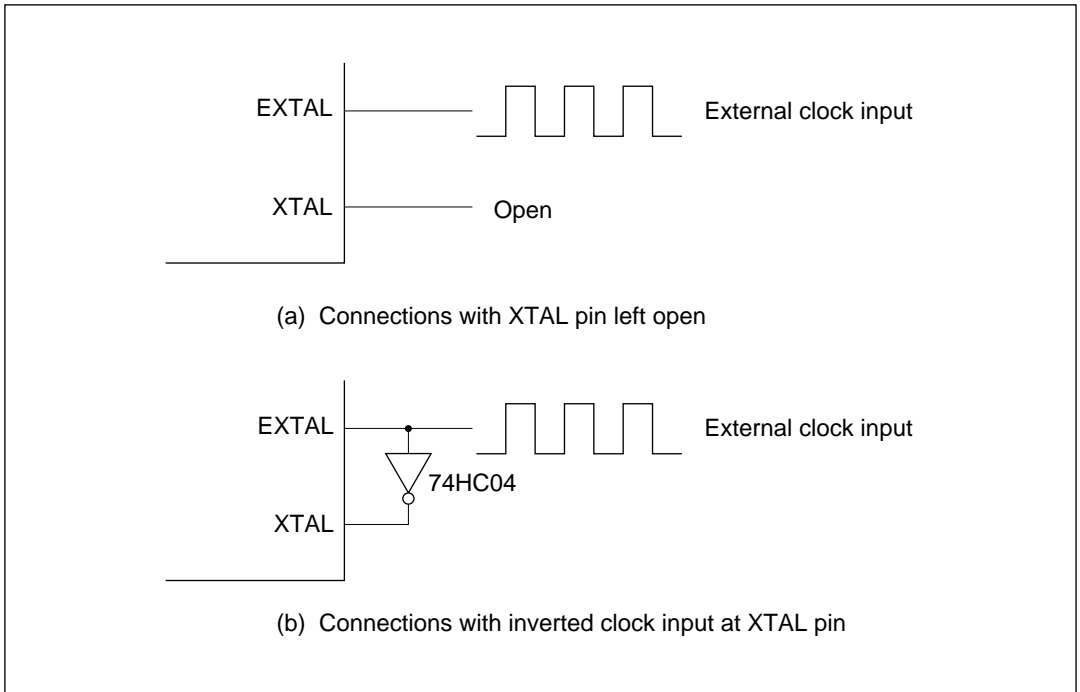

Figure 6-5 External Clock Input (Example)

② External Clock Input

The external clock signal should have the same frequency as the desired system clock (ϕ). Clock timing parameters are given in table 6-3 and figure 6-6.

Table 6-3 Clock Timing

Item	Symbol	$V_{CC} = 2.7 \text{ to } 5.5 \text{ V}$		$V_{CC} = 5.0 \text{ V } \pm 10\%$		Unit	Test Conditions
		Min	Max	Min	Max		
Low pulse width of external clock input	t_{EXL}	40	—	20	—	ns	Figure 6-6
High pulse width of external clock input	t_{EXH}	40	—	20	—	ns	
External clock rise time	t_{EXr}	—	10	—	5	ns	
External clock fall time	t_{EXf}	—	10	—	5	ns	
Clock pulse width low	t_{CL}	0.3	0.7	0.3	0.7	t_{cyc}	$\phi \geq 5 \text{ MHz}$ Figure 16-4
		0.4	0.6	0.4	0.6	t_{cyc}	$\phi < 5 \text{ MHz}$
Clock pulse width high	t_{CH}	0.3	0.7	0.3	0.7	t_{cyc}	$\phi \geq 5 \text{ MHz}$
		0.4	0.6	0.4	0.6	t_{cyc}	$\phi < 5 \text{ MHz}$

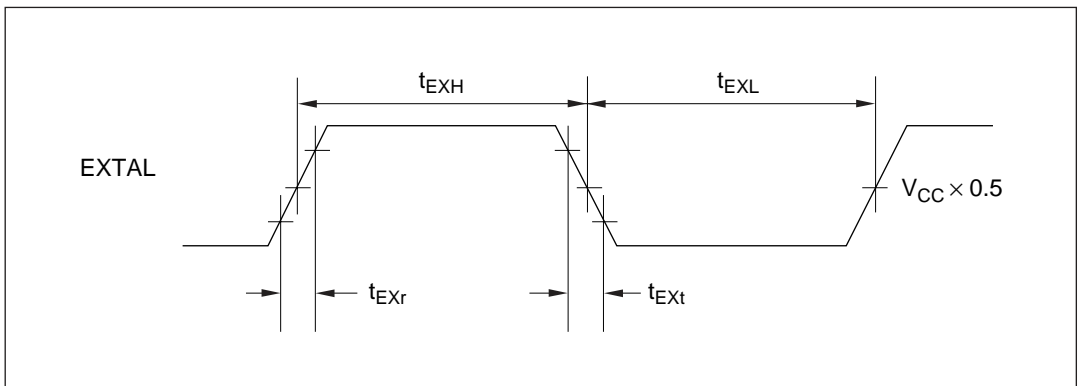

Figure 6-6 External Clock Input Timing

Table 6.4 shows the external clock output settling delay time, and figure 6.7 shows the external clock output settling delay timing. The oscillator and duty adjustment circuit have the function of adjusting the waveform of the external clock input at the EXTAL pin. When the specified clock signal is input at the EXTAL pin, internal clock signal output settles after the elapse of the external clock output settling delay time (t_{DEXT}). As the clock signal output remains unsettled during the t_{DEXT} period, the reset signal should be driven low to retain the reset state.

Table 6-4 External Clock Output Settling Delay Time

Conditions: $V_{\text{CC}} = 2.7 \text{ V to } 5.5 \text{ V}$, $AV_{\text{CC}} = 2.7 \text{ V to } 5.5 \text{ V}$, $V_{\text{SS}} = AV_{\text{SS}} = 0 \text{ V}$

Item	Symbol	Min	Max	Unit	Note
External clock output settling delay time	t_{DEXT}^*	500	–	μs	Figure 6-7

Note: * t_{DEXT} includes an $\overline{\text{RES}}$ pulse width (t_{RESW}) of $10 t_{\text{cyc}}$.

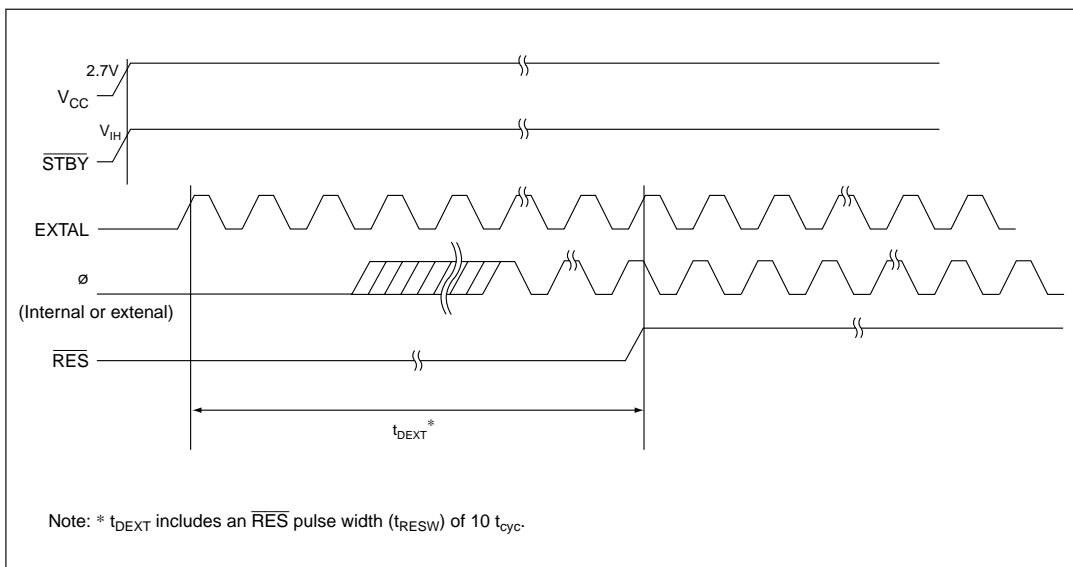

Figure 6-7 External Clock Output Settling Delay Time

6.3 Duty Adjustment Circuit

When the clock frequency is 5 MHz or above, the duty adjustment circuit adjusts the duty cycle of the signal from the oscillator circuit to generate the system clock (ϕ).

6.4 Prescaler

The clock for the on-chip supporting modules (ϕ_p) has either the same frequency as the system clock (ϕ) or this frequency divided by two, depending on the CKDBL bit. The prescaler divides the frequency of ϕ_p to generate internal clock signals with frequencies from $\phi_p/2$ to $\phi_p/4096$.

Section 7 I/O Ports

7.1 Overview

The H8/3297 Series has five 8-bit input/output ports, one 8-bit input port, and one 3-bit input/output port.

Table 7-1 lists the functions of each port in each operating mode. As table 7-1 indicates, the port pins are multiplexed, and the pin functions differ depending on the operating mode.

Each port has a data direction register (DDR) that selects input or output, and a data register (DR) that stores output data. If bit manipulation instructions will be executed on the port data direction registers, see “Notes on Bit Manipulation Instructions” in section 2.5.5, Bit Manipulation Instructions.

Ports 1 to 4, and 6 can drive one TTL load and a 90-pF capacitive load. Port 5 can drive one TTL load and a 30-pF capacitive load. Ports 1 and 2 can drive LEDs (with 10-mA current sink). Ports 1 to 6 can drive a darlington pair. Ports 1 to 3 have built-in MOS pull-up transistors.

For block diagrams of the ports, see appendix C, I/O Port Block Diagrams.

Table 7-1 Port Functions

Port	Description	Pins	Expanded Modes		Single-Chip Mode
			Mode 1	Mode 2	Mode 3
Port 1	<ul style="list-style-type: none"> • 8-bit I/O port • Can drive LEDs • Built-in input pull-ups 	P1 ₇ to P1 ₀ /A ₇ to A ₀	Lower address output (A ₇ to A ₀)	Lower address output (A ₇ to A ₀) or general input	General input/output
Port 2	<ul style="list-style-type: none"> • 8-bit I/O port • Can drive LEDs • Built-in input pull-ups 	P2 ₇ to P2 ₀ /A ₁₅ to A ₈	Upper address output (A ₁₅ to A ₈)	Upper address output (A ₁₅ to A ₈) or general input	General input/output
Port 3	<ul style="list-style-type: none"> • 8-bit I/O port • Built-in input pull-ups 	P3 ₇ to P3 ₀ / D ₇ to D ₀ /	Data bus (D ₇ to D ₀)		General input/output
Port 4	<ul style="list-style-type: none"> • 8-bit I/O port 	P4 ₇ /WAIT	Expanded data bus control input (WAIT)/ General input/output		General input/output
		P4 ₆ /ø	System clock (ø) output		ø output or general input
		P4 ₅ /AS P4 ₄ /WR P4 ₃ /RD	Expanded data bus control output (RD, WR, AS)		General input/output
		P4 ₂ /IRQ ₀ P4 ₁ /IRQ ₁ P4 ₀ /IRQ ₂ /ADTRG	Trigger input to A/D converter (ADTRG), external interrupt input (IRQ ₂ to IRQ ₀), or general input/output		
Port 5	<ul style="list-style-type: none"> • 3-bit I/O port 	P5 ₂ /SCK P5 ₁ /RxD P5 ₀ /TxD	Serial communication interface input/output (TxD, RxD, SCK) or general input/output		
Port 6	<ul style="list-style-type: none"> • 8-bit I/O port 	P6 ₇ /TMO ₁ P6 ₆ /FTOB/TMR ₁ P6 ₅ /FTID/TMCl ₁ P6 ₄ /FTIC/TMO ₀ P6 ₃ /FTIB/TMR ₀ P6 ₂ /FTIA P6 ₁ /FTOA P6 ₀ /FTCl/TMCl ₀	16-bit free-running timer input/output (FTCl, FTOA, FTIA, FTIB, FTIC, FTID, FTOB), 8-bit timer 0/1 input/output (TMCl ₀ , TMO ₀ , TMR ₀ , TMCl ₁ , TMO ₁ , TMR ₁) or general input/output		
Port 7	<ul style="list-style-type: none"> • 8-bit input port 	P7 ₇ to P7 ₀ AN ₇ to AN ₀	Analog input to A/D converter (AN ₇ to AN ₀) or general input		

7.2 Port 1

7.2.1 Overview

Port 1 is an 8-bit input/output port with the pin configuration shown in figure 7-1. The pin functions differ depending on the operating mode.

Port 1 has built-in, software-controllable MOS input pull-up transistors that can be used in modes 2 and 3.

Pins in port 1 can drive one TTL load and a 90-pF capacitive load. They can also drive LEDs and darlington transistors.

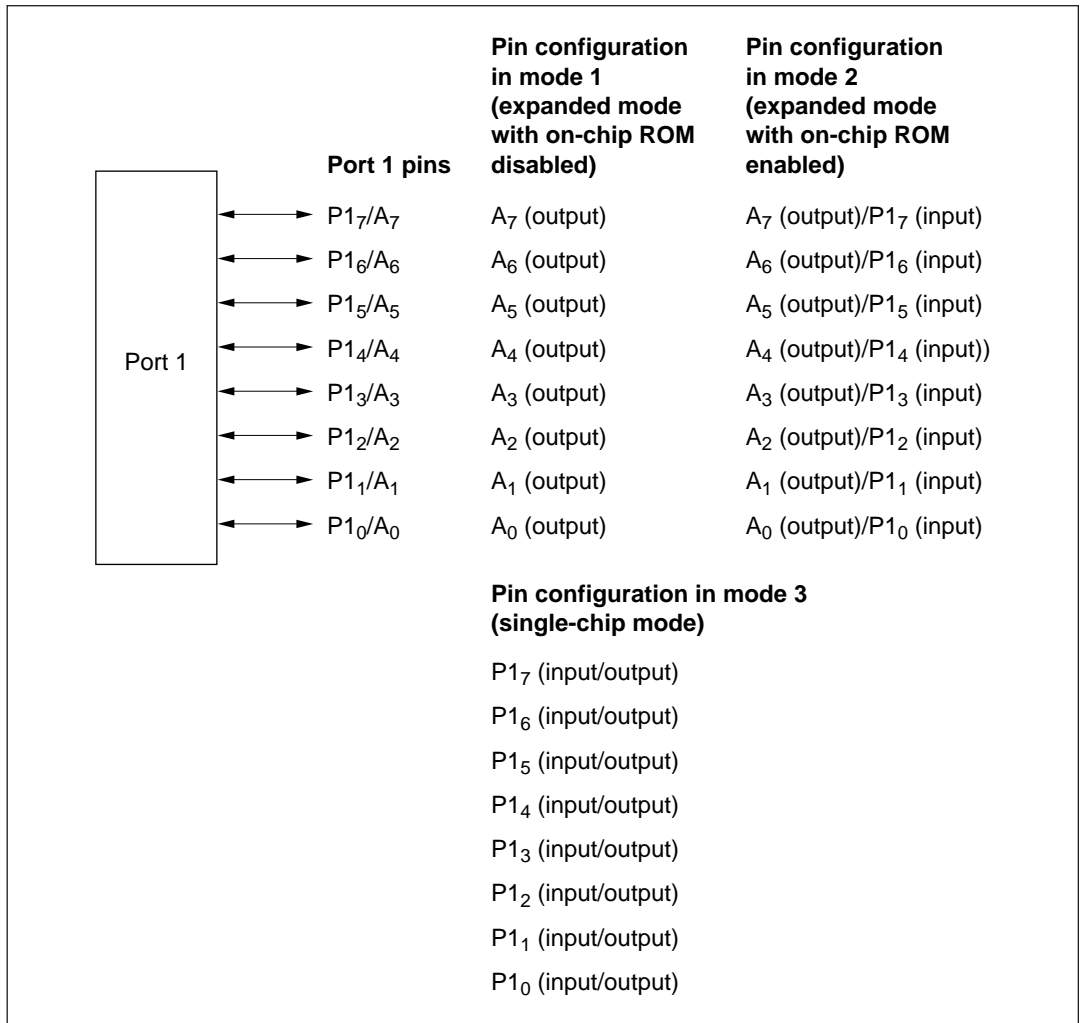

Figure 7-1 Port 1 Pin Configuration

7.2.2 Register Configuration and Descriptions

Table 7-2 summarizes the port 1 registers.

Table 7-2 Port 1 Registers

Name	Abbreviation	Read/Write	Initial Value	Address
Port 1 data direction register	P1DDR	W	H'FF (mode 1) H'00 (modes 2 and 3)	H'FFB0
Port 1 data register	P1DR	R/W	H'00	H'FFB2
Port 1 input pull-up control register	P1PCR	R/W	H'00	H'FFAC

Port 1 Data Direction Register (P1DDR)

Bit	7	6	5	4	3	2	1	0
	P1 ₇ DDR	P1 ₆ DDR	P1 ₅ DDR	P1 ₄ DDR	P1 ₃ DDR	P1 ₂ DDR	P1 ₁ DDR	P1 ₀ DDR
Mode 1								
Initial value	1	1	1	1	1	1	1	1
Read/Write	—	—	—	—	—	—	—	—
Modes 2 and 3								
Initial value	0	0	0	0	0	0	0	0
Read/Write	W	W	W	W	W	W	W	W

P1DDR controls the input/output direction of each pin in port 1.

Mode 1: The P1DDR values are fixed at 1. Port 1 consists of lower address output pins. P1DDR values cannot be modified and are always read as 1.

In hardware standby mode, the address bus is in the high-impedance state.

Mode 2: A pin in port 1 is used for address output if the corresponding P1DDR bit is set to 1, and for general input if this bit is cleared to 0.

Mode 3: A pin in port 1 is used for general output if the corresponding P1DDR bit is set to 1, and for general input if this bit is cleared to 0.

In modes 2 and 3, P1DDR is a write-only register. Read data is invalid. If read, all bits always read 1. P1DDR is initialized to H'00 by a reset and in hardware standby mode. In software standby mode it retains its existing values, so if a transition to software standby mode occurs while a P1DDR bit is set to 1, the corresponding pin remains in the output state.

Port 1 Data Register (P1DR)

Bit	7	6	5	4	3	2	1	0
	P ₇	P ₆	P ₅	P ₄	P ₃	P ₂	P ₁	P ₀
Initial value	0	0	0	0	0	0	0	0
Read/Write	R/W	R/W	R/W	R/W	R/W	R/W	R/W	R/W

P1DR is an 8-bit register that stores data for pins P1₇ to P1₀. When a P1DDR bit is set to 1, if port 1 is read, the value in P1DR is obtained directly, regardless of the actual pin state. When a P1DDR bit is cleared to 0, if port 1 is read the pin state is obtained.

P1DR is initialized to H'00 by a reset and in hardware standby mode. In software standby mode it retains its existing values.

Port 1 Input Pull-Up Control Register (P1PCR)

Bit	7	6	5	4	3	2	1	0
	P ₇ PCR	P ₆ PCR	P ₅ PCR	P ₄ PCR	P ₃ PCR	P ₂ PCR	P ₁ PCR	P ₀ PCR
Initial value	0	0	0	0	0	0	0	0
Read/Write	R/W	R/W	R/W	R/W	R/W	R/W	R/W	R/W

P1PCR is an 8-bit readable/writable register that controls the input pull-up transistors in port 1. If a P1DDR bit is cleared to 0 (designating input) and the corresponding P1PCR bit is set to 1, the input pull-up transistor is turned on.

P1PCR is initialized to H'00 by a reset and in hardware standby mode. In software standby mode it retains its existing values.

7.2.3 Pin Functions in Each Mode

Port 1 has different pin functions in different modes. A separate description for each mode is given below.

Pin Functions in Mode 1: In mode 1 (expanded mode with on-chip ROM disabled), port 1 is automatically used for lower address output (A_7 to A_0). Figure 7-2 shows the pin functions in mode 1.

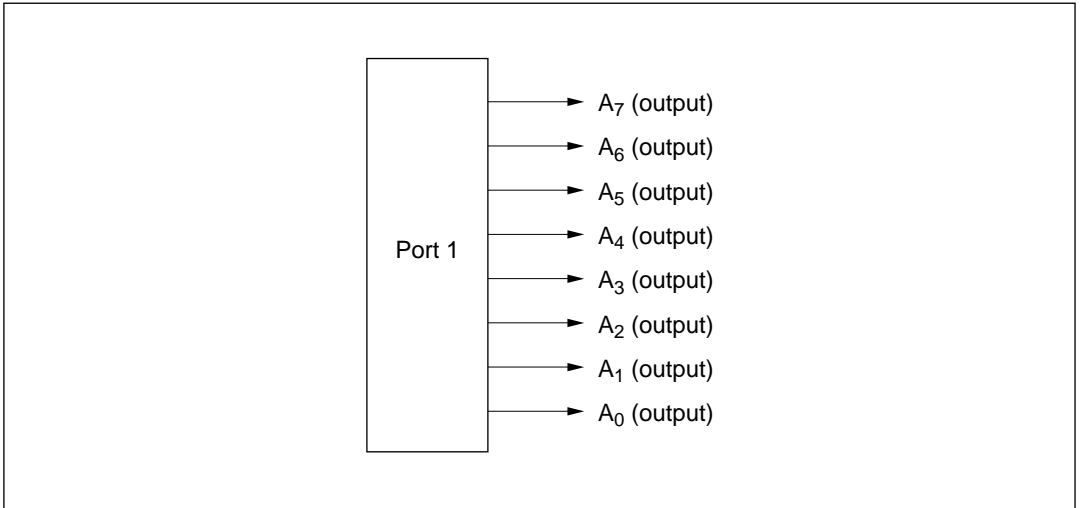

Figure 7-2 Pin Functions in Mode 1 (Port 1)

Mode 2: In mode 2 (expanded mode with on-chip ROM enabled), port 1 can provide lower address output pins and general input pins. Each pin becomes a lower address output pin if its P1DDR bit is set to 1, and a general input pin if this bit is cleared to 0. Following a reset, all pins are input pins. To be used for address output, their P1DDR bits must be set to 1. Figure 7-3 shows the pin functions in mode 2.

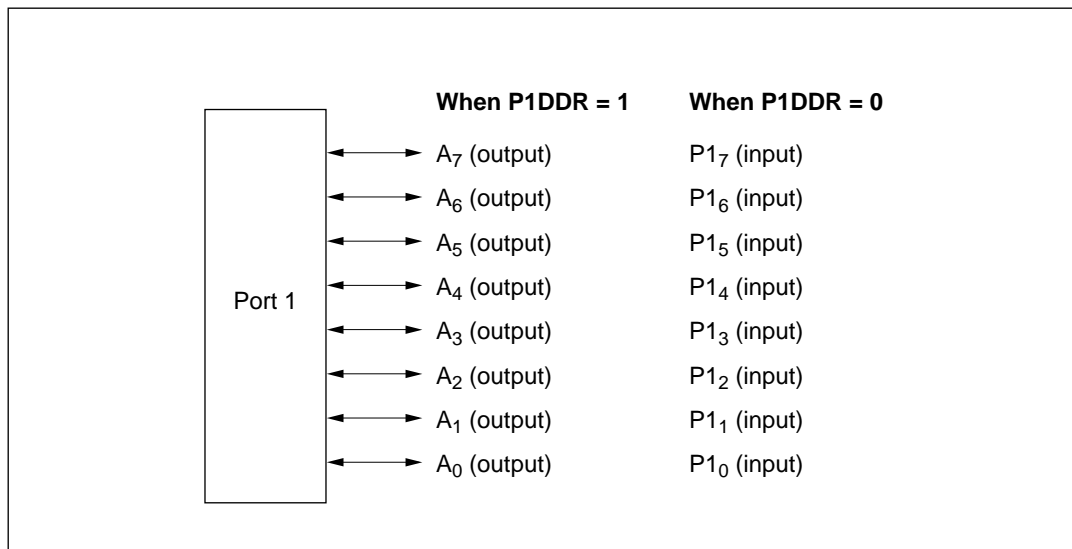

Figure 7-3 Pin Functions in Mode 2 (Port 1)

Mode 3: In mode 3 (single-chip mode), the input or output direction of each pin can be selected individually. A pin becomes a general input pin when its P1DDR bit is cleared to 0 and a general output pin when this bit is set to 1. Figure 7-4 shows the pin functions in mode 3.

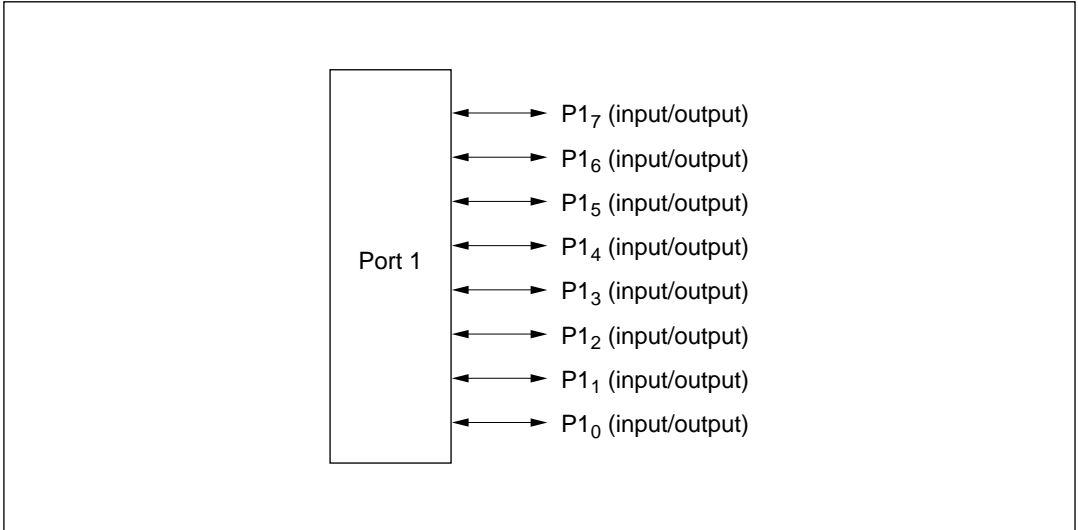

Figure 7-4 Pin Functions in Mode 3 (Port 1)

7.2.4 Input Pull-Up Transistors

Port 1 has built-in programmable input pull-up transistors that are available in modes 2 and 3. The pull-up for each bit can be turned on and off individually. To turn on an input pull-up in mode 2 or 3, set the corresponding P1PCR bit to 1 and clear the corresponding P1DDR bit to 0. P1PCR is cleared to H'00 by a reset and in hardware standby mode, turning all input pull-ups off. In software standby mode, the previous state is maintained.

Table 7-3 indicates the states of the input pull-up transistors in each operating mode.

Table 7-3 States of Input Pull-Up Transistors (Port 1)

Mode	Reset	Hardware Standby	Software Standby	Other Operating Modes
1	Off	Off	Off	Off
2	Off	Off	On/off	On/off
3	Off	Off	On/off	On/off

Notes: Off: The input pull-up transistor is always off.

On/off: The input pull-up transistor is on if P1PCR = 1 and P1DDR = 0, but off otherwise.

7.3 Port 2

7.3.1 Overview

Port 2 is an 8-bit input/output port with the pin configuration shown in figure 7-5. The pin functions differ depending on the operating mode.

Port 2 has built-in, software-controllable MOS input pull-up transistors that can be used in modes 2 and 3.

Pins in port 2 can drive one TTL load and a 90-pF capacitive load. They can also drive LEDs and darlington transistors.

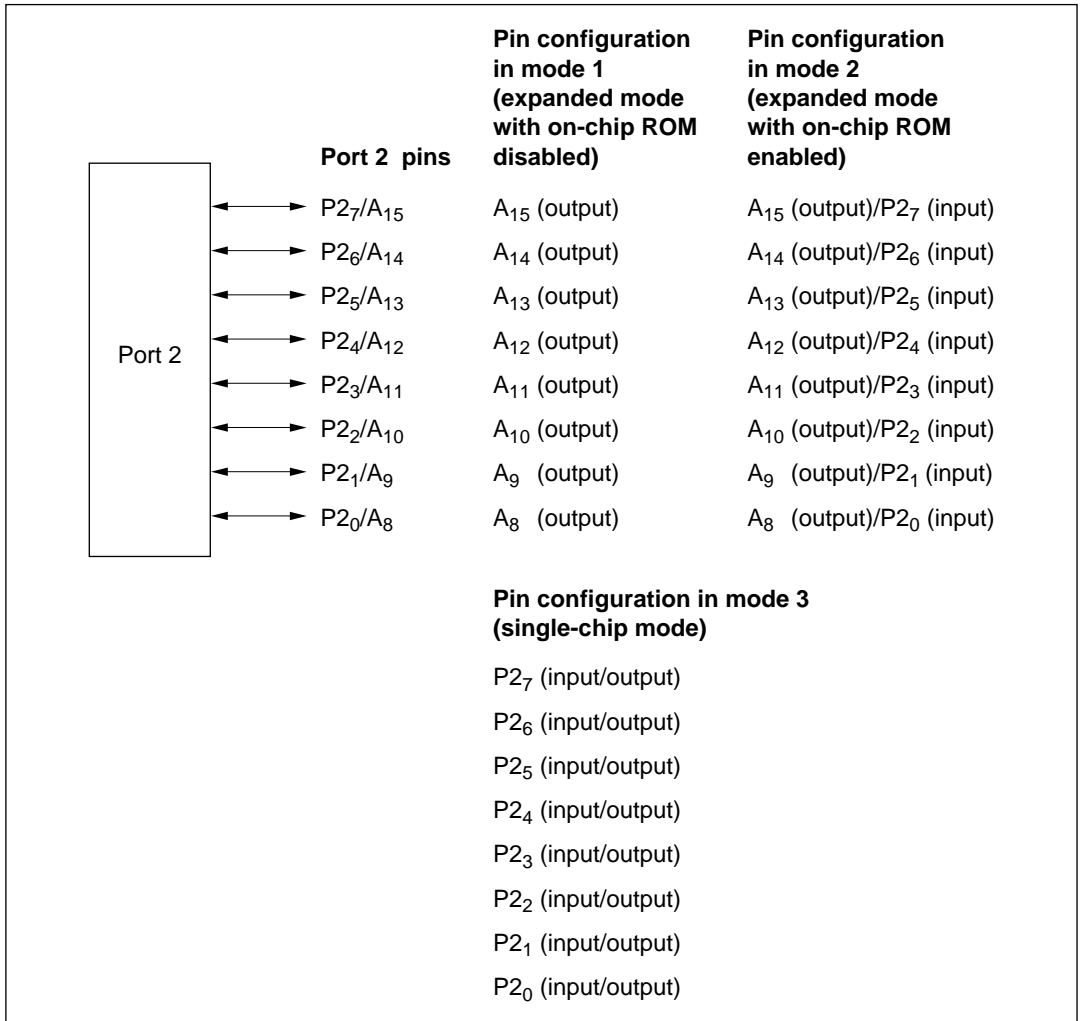

Figure 7-5 Port 2 Pin Configuration

7.3.2 Register Configuration and Descriptions

Table 7-4 summarizes the port 2 registers.

Table 7-4 Port 2 Registers

Name	Abbreviation	Read/Write	Initial Value	Address
Port 2 data direction register	P2DDR	W	H'FF (mode 1) H'00 (modes 2 and 3)	H'FFB1
Port 2 data register	P2DR	R/W	H'00	H'FFB3
Port 2 input pull-up control register	P2PCR	R/W	H'00	H'FFAD

Port 2 Data Direction Register (P2DDR)

Bit	7	6	5	4	3	2	1	0
	P2 ₇ DDR	P2 ₆ DDR	P2 ₅ DDR	P2 ₄ DDR	P2 ₃ DDR	P2 ₂ DDR	P2 ₁ DDR	P2 ₀ DDR
Mode 1								
Initial value	1	1	1	1	1	1	1	1
Read/Write	—	—	—	—	—	—	—	—
Modes 2 and 3								
Initial value	0	0	0	0	0	0	0	0
Read/Write	W	W	W	W	W	W	W	W

P2DDR controls the input/output direction of each pin in port 2.

Mode 1: The P2DDR values are fixed at 1. Port 2 consists of upper address output pins. P2DDR values cannot be modified and are always read as 1.

In hardware standby mode, the address bus is in the high-impedance state.

Mode 2: A pin in port 2 is used for address output if the corresponding P2DDR bit is set to 1, and for general input if this bit is cleared to 0.

Mode 3: A pin in port 2 is used for general output if the corresponding P2DDR bit is set to 1, and for general input if this bit is cleared to 0.

In modes 2 and 3, P2DDR is a write-only register. Read data is invalid. If read, all bits always read 1. P2DDR is initialized to H'00 by a reset and in hardware standby mode. In software standby mode it retains its existing values, so if a transition to software standby mode occurs while a P2DDR bit is set to 1, the corresponding pin remains in the output state.

Port 2 Data Register (P2DR)

Bit	7	6	5	4	3	2	1	0
	P2 ₇	P2 ₆	P2 ₅	P2 ₄	P2 ₃	P2 ₂	P2 ₁	P2 ₀
Initial value	0	0	0	0	0	0	0	0
Read/Write	R/W	R/W	R/W	R/W	R/W	R/W	R/W	R/W

P2DR is an 8-bit register that stores data for pins P2₇ to P2₀. When a P2DDR bit is set to 1, if port 2 is read, the value in P2DR is obtained directly, regardless of the actual pin state. When a P2DDR bit is cleared to 0, if port 2 is read the pin state is obtained.

P2DR is initialized to H'00 by a reset and in hardware standby mode. In software standby mode it retains its existing values.

Port 2 Input Pull-Up Control Register (P2PCR)

Bit	7	6	5	4	3	2	1	0
	P2 ₇ PCR	P2 ₆ PCR	P2 ₅ PCR	P2 ₄ PCR	P2 ₃ PCR	P2 ₂ PCR	P2 ₁ PCR	P2 ₀ PCR
Initial value	0	0	0	0	0	0	0	0
Read/Write	R/W	R/W	R/W	R/W	R/W	R/W	R/W	R/W

P2PCR is an 8-bit readable/writable register that controls the input pull-up transistors in port 2. If a P2DDR bit is cleared to 0 (designating input) and the corresponding P2PCR bit is set to 1, the input pull-up transistor is turned on.

P2PCR is initialized to H'00 by a reset and in hardware standby mode. In software standby mode it retains its existing values.

7.3.3 Pin Functions in Each Mode

Port 2 has different pin functions in different modes. A separate description for each mode is given below.

Pin Functions in Mode 1: In mode 1 (expanded mode with on-chip ROM disabled), port 2 is automatically used for upper address output (A_{15} to A_8). Figure 7-6 shows the pin functions in mode 1.

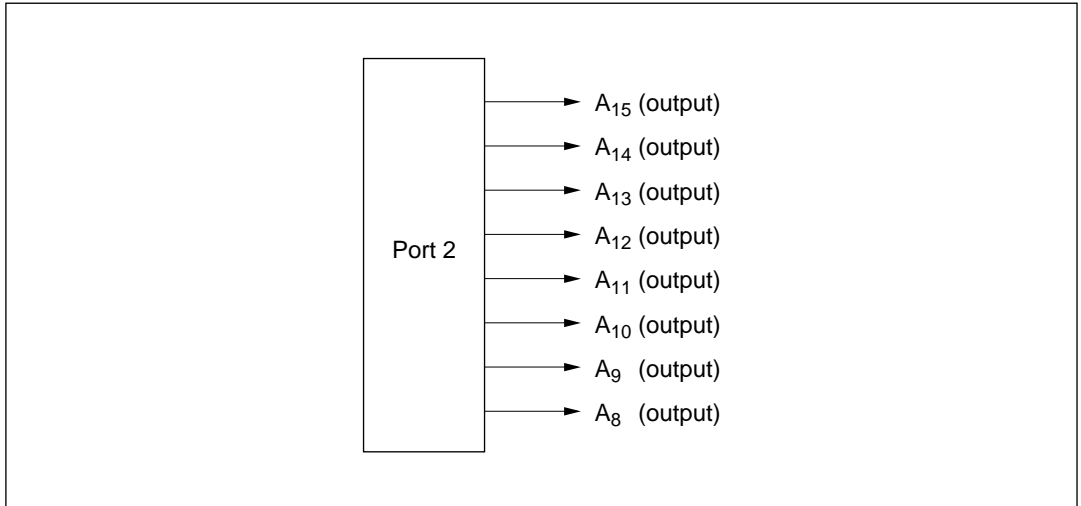

Figure 7-6 Pin Functions in Mode 1 (Port 2)

Mode 2: In mode 2 (expanded mode with on-chip ROM enabled), port 2 can provide upper address output pins and general input pins. Each pin becomes an upper address output pin if its P2DDR bit is set to 1, and a general input pin if this bit is cleared to 0. Following a reset, all pins are input pins. To be used for address output, their P2DDR bits must be set to 1. Figure 7-7 shows the pin functions in mode 2.

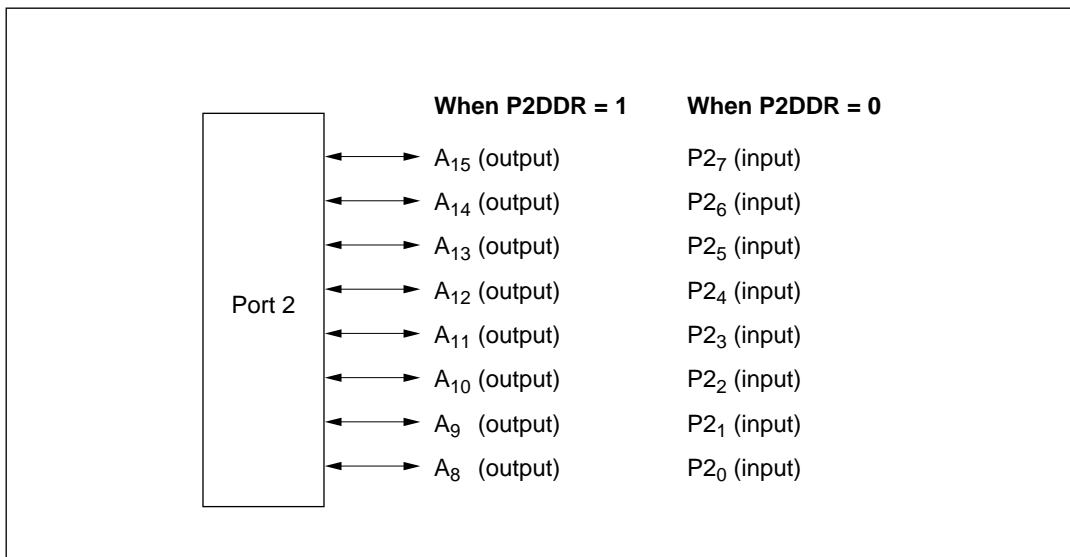

Figure 7-7 Pin Functions in Mode 2 (Port 2)

Mode 3: In mode 3 (single-chip mode), the input or output direction of each pin can be selected individually. A pin becomes a general input pin when its P2DDR bit is cleared to 0, and a general output pin when this bit is set to 1. Figure 7-8 shows the pin functions in mode 3.

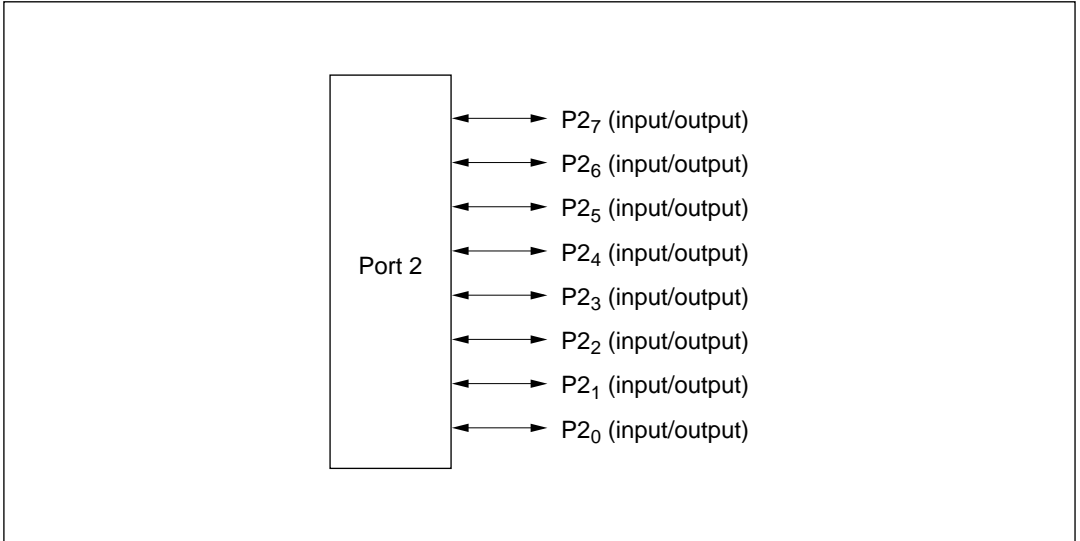

Figure 7-8 Pin Functions in Mode 3 (Port 2)

7.3.4 Input Pull-Up Transistors

Port 2 has built-in programmable input pull-up transistors that are available in modes 2 and 3. The pull-up for each bit can be turned on and off individually. To turn on an input pull-up in mode 2 or 3, set the corresponding P2PCR bit to 1 and clear the corresponding P2DDR bit to 0. P2PCR is cleared to H'00 by a reset and in hardware standby mode, turning all input pull-ups off. In software standby mode, the previous state is maintained.

Table 7-5 indicates the states of the input pull-up transistors in each operating mode.

Table 7-5 States of Input Pull-Up Transistors (Port 2)

Mode	Reset	Hardware Standby	Software Standby	Other Operating Modes
1	Off	Off	Off	Off
2	Off	Off	On/off	On/off
3	Off	Off	On/off	On/off

Notes: Off: The input pull-up transistor is always off.

On/off: The input pull-up transistor is on if P2PCR = 1 and P2DDR = 0, but off otherwise.

7.4 Port 3

7.4.1 Overview

Port 3 is an 8-bit input/output port with the pin configuration shown in Figure 7-9. The pin functions differ depending on the operating mode.

Port 3 has built-in, software-controllable MOS input pull-up transistors that can be used in mode 3.

Pins in port 3 can drive one TTL load and a 90-pF capacitive load. They can also drive a darlington pair.

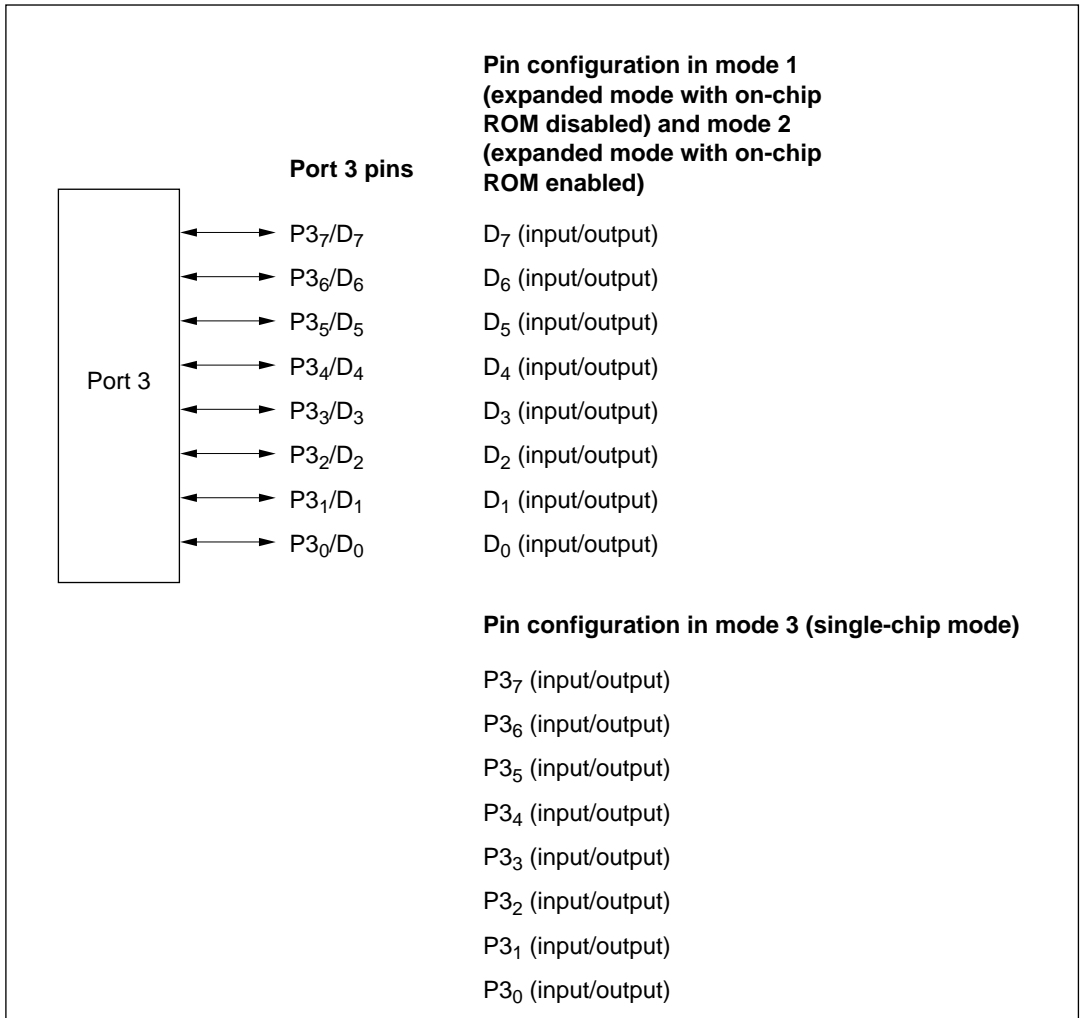

Figure 7-9 Port 3 Pin Configuration

7.4.2 Register Configuration and Descriptions

Table 7-6 summarizes the port 3 registers.

Table 7-6 Port 3 Registers

Name	Abbreviation	Read/Write	Initial Value	Address
Port 3 data direction register	P3DDR	W	H'00	H'FFB4
Port 3 data register	P3DR	R/W	H'00	H'FFB6
Port 3 input pull-up control register	P3PCR	R/W	H'00	H'FFAE

Port 3 Data Direction Register (P3DDR)

Bit	7	6	5	4	3	2	1	0
	P3 ₇ DDR	P3 ₆ DDR	P3 ₅ DDR	P3 ₄ DDR	P3 ₃ DDR	P3 ₂ DDR	P3 ₁ DDR	P3 ₀ DDR
Initial value	0	0	0	0	0	0	0	0
Read/Write	W	W	W	W	W	W	W	W

P3DDR is an 8-bit readable/writable register that controls the input/output direction of each pin in port 3. P3DDR is a write-only register. Read data is invalid. If read, all bits always read 1.

Modes 1 and 2: In mode 1 (expanded mode with on-chip ROM disabled) and mode 2 (expanded mode with on-chip ROM enabled), the input/output directions designated by P3DDR are ignored. Port 3 automatically consists of the input/output pins of the 8-bit data bus (D₇ to D₀).

The data bus is in the high-impedance state during reset, and during hardware and software standby.

Mode 3: A pin in port 3 is used for general output if the corresponding P3DDR bit is set to 1, and for general input if this bit is cleared to 0. P3DDR is initialized to H'00 by a reset and in hardware standby mode. In software standby mode it retains its existing values, so if a transition to software standby mode occurs while a P3DDR bit is set to 1, the corresponding pin remains in the output state.

Port 3 Data Register (P3DR)

Bit	7	6	5	4	3	2	1	0
	P3 ₇	P3 ₆	P3 ₅	P3 ₄	P3 ₃	P3 ₂	P3 ₁	P3 ₀
Initial value	0	0	0	0	0	0	0	0
Read/Write	R/W	R/W	R/W	R/W	R/W	R/W	R/W	R/W

P3DR is an 8-bit register that stores data for pins P3₇ to P3₀. When a P3DDR bit is set to 1, if port 3 is read, the value in P3DR is obtained directly, regardless of the actual pin state. When a P3DDR bit is cleared to 0, if port 3 is read the pin state is obtained.

P3DR is initialized to H'00 by a reset and in hardware standby mode. In software standby mode it retains its existing values.

Port 3 Input Pull-Up Control Register (P3PCR)

Bit	7	6	5	4	3	2	1	0
	P3 ₇ PCR	P3 ₆ PCR	P3 ₅ PCR	P3 ₄ PCR	P3 ₃ PCR	P3 ₂ PCR	P3 ₁ PCR	P3 ₀ PCR
Initial value	0	0	0	0	0	0	0	0
Read/Write	R/W	R/W	R/W	R/W	R/W	R/W	R/W	R/W

P3PCR is an 8-bit readable/writable register that controls the input pull-up transistors in port 3. If a P3DDR bit is cleared to 0 (designating input) and the corresponding P3PCR bit is set to 1, the input pull-up transistor is turned on.

P3PCR is initialized to H'00 by a reset and in hardware standby mode. In software standby mode it retains its existing values.

The input pull-ups cannot be used in slave mode (when the host interface is enabled).

7.4.3 Pin Functions in Each Mode

Port 3 has different pin functions in different modes. A separate description for each mode is given below.

Pin Functions in Modes 1 and 2: In mode 1 (expanded mode with on-chip ROM disabled) and mode 2 (expanded mode with on-chip ROM enabled), port 3 is automatically used for the input/output pins of the data bus (D₇ to D₀). Figure 7-10 shows the pin functions in modes 1 and 2.

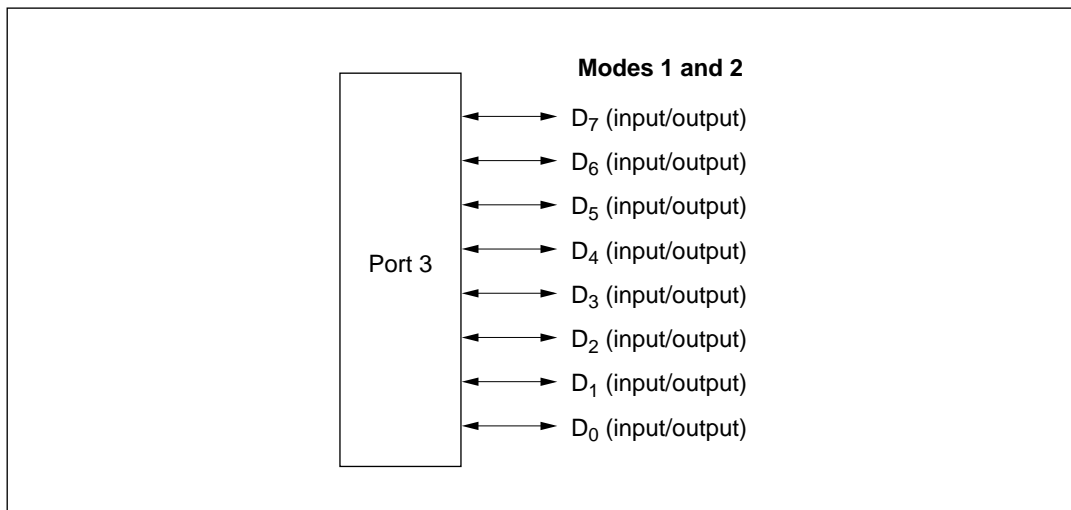

Figure 7-10 Pin Functions in Modes 1 and 2 (Port 3)

Mode 3: In mode 3 (single-chip mode), the input or output direction of each pin can be selected individually. A pin becomes a general input pin when its P3DDR bit is cleared to 0, and a general output pin when this bit is set to 1.

Figure 7-11 shows the pin functions in mode 3.

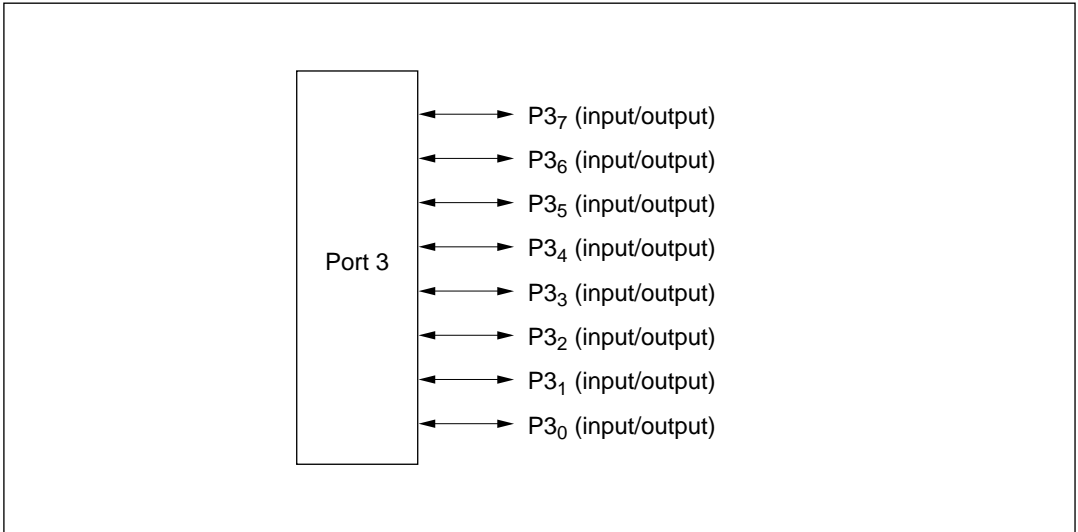

Figure 7-11 Pin Functions in Mode 3 (Port 3)

7.4.4 Input Pull-Up Transistors

Port 3 has built-in programmable input pull-up transistors that are available in mode 3. The pull-up for each bit can be turned on and off individually. To turn on an input pull-up in mode 3, set the corresponding P3PCR bit to 1 and clear the corresponding P3DDR bit to 0. P3PCR is cleared to H'00 by a reset and in hardware standby mode, turning all input pull-ups off. In software standby mode, the previous state is maintained.

Table 7-7 indicates the states of the input pull-up transistors in each operating mode.

Table 7-7 States of Input Pull-Up Transistors (Port 3)

Mode	Reset	Hardware Standby	Software Standby	Other Operating Modes
1	Off	Off	Off	Off
2	Off	Off	Off	Off
3	Off	Off	On/off	On/off

Notes: Off: The input pull-up transistor is always off.

On/off: The input pull-up transistor is on if P3PCR = 1 and P3DDR = 0, but off otherwise.

7.5 Port 4

7.5.1 Overview

Port 4 is an 8-bit input/output port that is multiplexed with interrupt input pins ($\overline{\text{IRQ}}_0$ to $\overline{\text{IRQ}}_2$), input/output pins for bus control signals ($\overline{\text{RD}}$, $\overline{\text{WR}}$, $\overline{\text{AS}}$, $\overline{\text{WAIT}}$), an input pin ($\overline{\text{ADTRG}}$) for the A/D converter, and an output pin (\emptyset) for the system clock. Figure 7-12 shows the pin configuration of port 4.

Pins in port 4 can drive one TTL load and a 90-pF capacitive load.

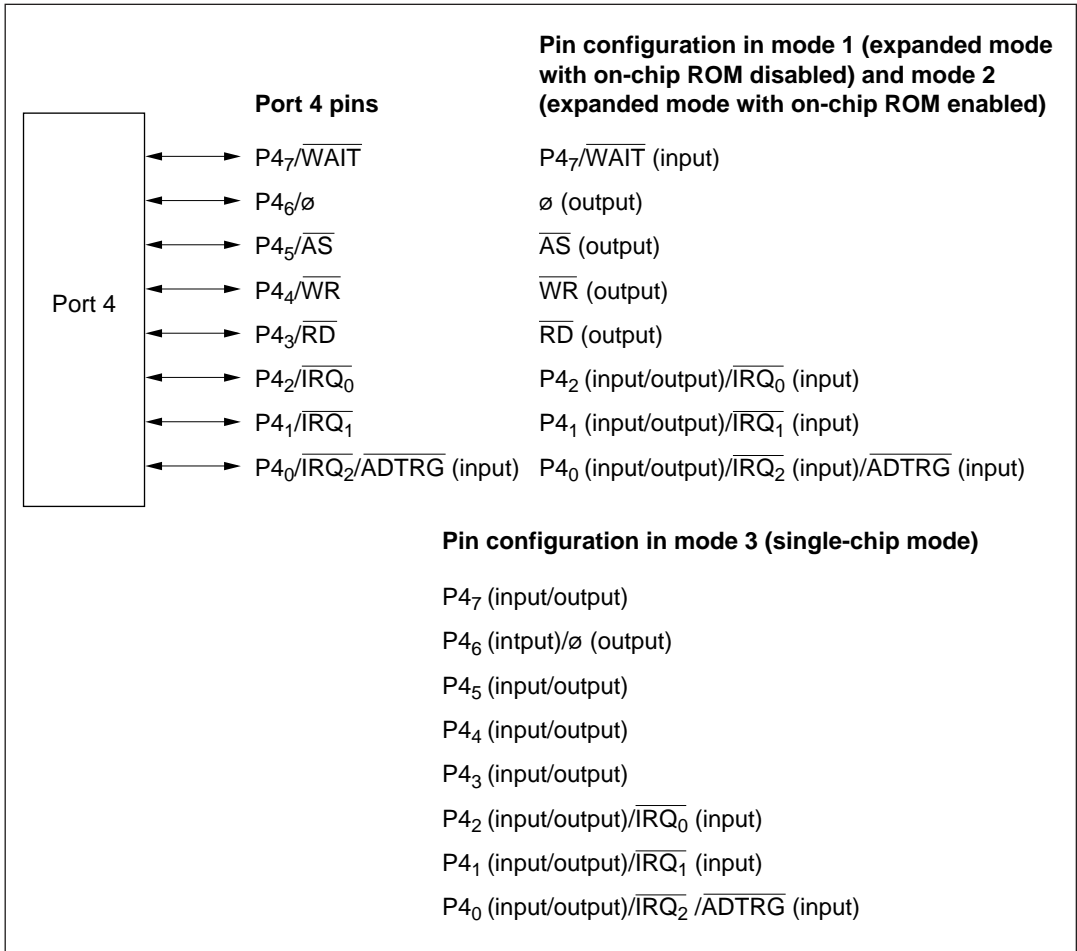

Figure 7-12 Port 4 Pin Configuration

7.5.2 Register Configuration and Descriptions

Table 7-8 summarizes the port 4 registers.

Table 7-8 Port 4 Registers

Name	Abbreviation	Read/Write	Initial Value	Address
Port 4 data direction register	P4DDR	W	H'40 (modes 1 and 2) H'00 (mode 3)	H'FFB5
Port 4 data register	P4DR	R/W*1	Undetermined*2	H'FFB7

Notes: 1. Bit 6 is read-only.
2. Bit 6 is undetermined. Other bits are initially 0.

Port 4 Data Direction Register (P4DDR)

	7	6	5	4	3	2	1	0
Bit	P4 ₇ DDR	P4 ₆ DDR	P4 ₅ DDR	P4 ₄ DDR	P4 ₃ DDR	P4 ₂ DDR	P4 ₁ DDR	P4 ₀ DDR
Modes 1, 2								
Initial value	0	1	0	0	0	0	0	0
Read/Write	W	—	W	W	W	W	W	W
Mode 3								
Initial value	0	0	0	0	0	0	0	0
Read/Write	W	W	W	W	W	W	W	W

P4DDR is an 8-bit readable/writable register that controls the input/output direction of each pin in port 4. A pin functions as an output pin if the corresponding P4DDR bit is set to 1, and as an input pin if this bit is cleared to 0. In modes 1 and 2, P4₆DDR is fixed at 1 and cannot be modified.

P4DDR is a write-only register. Read data is invalid. If read, all bits always read 1.

P4DDR is initialized by a reset and in hardware standby mode. The initial value is H'40 in modes 1 and 2, and H'00 in mode 3. In software standby mode P4DDR retains its existing values, so if a transition to software standby mode occurs while a P4DDR bit is set to 1, the corresponding pin remains in the output state.

Port 4 Data Register (P4DR)

Bit	7	6	5	4	3	2	1	0
	P4 ₇	P4 ₆	P4 ₅	P4 ₄	P4 ₃	P4 ₂	P4 ₁	P4 ₀
Initial value	0	*	0	0	0	0	0	0
Read/Write	R/W	R	R/W	R/W	R/W	R/W	R/W	R/W

Note: * Determined by the level at pin P4₆.

P4DR is an 8-bit register that stores data for pins P4₆ to P4₀. When a P4DDR bit is set to 1, if port 4 is read, the value in P4DR is obtained directly, regardless of the actual pin state, except for P4₆. When a P4DDR bit is cleared to 0, if port 4 is read the pin state is obtained. This also applies to pins used by on-chip supporting modules and for bus control signals. P4₆ always returns the pin state.

P4DR is initialized to H'00 by a reset and in hardware standby mode. In software standby mode it retains its existing values.

7.5.3 Pin Functions

Port 4 has one set of pin functions in modes 1 and 2, and a different set of pin functions in mode 3. The pins are multiplexed with $\overline{\text{IRQ}}_0$ to $\overline{\text{IRQ}}_2$ input, bus control signal input/output, A/D converter input, and system clock (\emptyset) output. Table 7-9 indicates the pin functions of port 4.

Table 7-9 Port 4 Pin Functions

Pin	Pin Functions and Selection Method					
P4 ₇ / $\overline{\text{WAIT}}$	Bit P4 ₇ DDR, the operating mode, and the wait mode determined by WSCR select the pin function as follows					
	Operating mode	Modes 1 and 2			Mode 3	
	Wait mode	$\overline{\text{WAIT}}$ used	$\overline{\text{WAIT}}$ not used (WMS1=0, WMS0=1)		—	
	P4 ₇ DDR	—	0	1	0	1
	Pin function	$\overline{\text{WAIT}}$ input	P4 ₇ input	P4 ₇ output	P4 ₇ input	P4 ₇ output
P4 ₆ / \emptyset	Bit P4 ₆ DDR and the operating mode select the pin function as follows					
	Operating mode	Modes 1 and 2	Mode 3			
	P4 ₆ DDR	Always 1	0		1	
	Pin function	\emptyset output	P4 ₆ input		\emptyset output	

Table 7-19 Port 4 Pin Functions (cont)

Pin Pin Functions and Selection Method

$P4_5/\overline{AS}$ Bit $P4_5$ DDR and the operating mode select the pin function as follows

Operating mode	Modes 1 and 2	Mode 3	
$P4_5$ DDR	—	0	1
Pin function	\overline{AS} output	$P4_5$ input	$P4_5$ output

$P4_4/\overline{WR}$ Bit $P4_4$ DDR and the operating mode select the pin function as follows

Operating mode	Modes 1 and 2	Mode 3	
$P4_4$ DDR	—	0	1
Pin function	\overline{WR} output	$P4_4$ input	$P4_4$ output

$P4_3/\overline{RD}$ Bit $P4_3$ DDR and the operating mode select the pin function as follows

Operating mode	Modes 1 and 2	Mode 3	
$P4_3$ DDR	—	0	1
Pin function	\overline{RD} output	$P4_3$ input	$P4_3$ output

$P4_2/\overline{IRQ_0}$

$P4_2$ DDR	0	1
Pin function	$P4_2$ input	$P4_2$ output
	$\overline{IRQ_0}$ input	

$\overline{IRQ_0}$ input can be used when bit $IRQ0E$ is set to 1 in IER

$P4_1/\overline{IRQ_1}$

$P4_1$ DDR	0	1
Pin function	$P4_1$ input	$P4_1$ output
	$\overline{IRQ_1}$ input	

$\overline{IRQ_1}$ input can be used when bit $IRQ1E$ is set to 1 in IER

$P4_0/\overline{IRQ_2}/$
 $ADTRG$

$P4_0$ DDR	0	1
Pin function	$P4_0$ input	$P4_0$ output
	$\overline{IRQ_2}$ input and $ADTRG$ input	

$\overline{IRQ_2}$ input can be used when bit $IRQ2E$ is set to 1 in IER

$ADTRG$ input can be used when bit $TRGE$ is set to 1 in $ADCR$

7.6 Port 5

7.6.1 Overview

Port 5 is a 3-bit input/output port that is multiplexed with input/output pins (TxD, RxD, SCK) of serial communication interface. The port 5 pin functions are the same in all operating modes. Figure 7-13 shows the pin configuration of port 5.

Pins in port 5 can drive one TTL load and a 30-pF capacitive load. They can also drive a darlington pair.

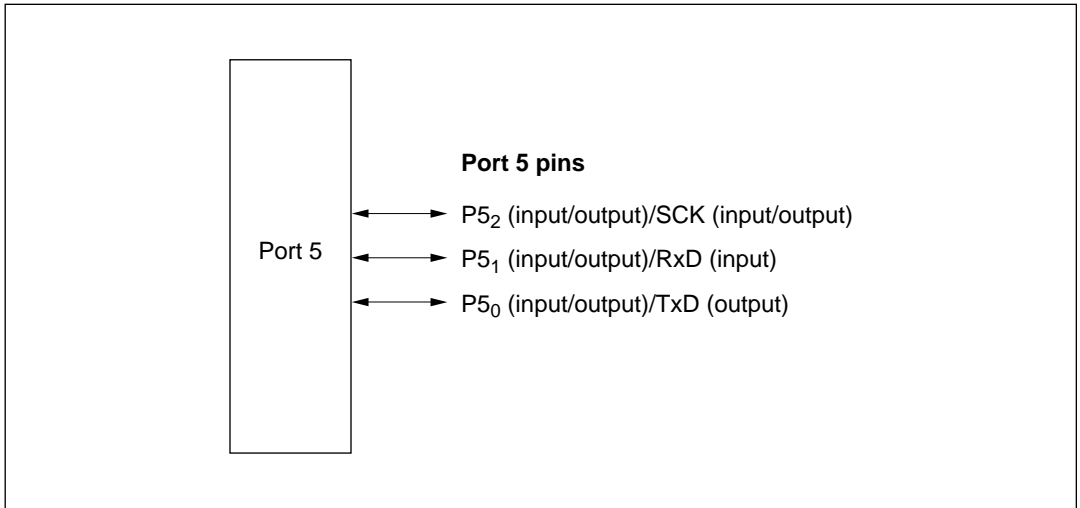

Figure 7-13 Port 5 Pin Configuration

7.6.2 Register Configuration and Descriptions

Table 7-10 summarizes the port 5 registers.

Table 7-10 Port 5 Registers

Name	Abbreviation	Read/Write	Initial Value	Address
Port 5 data direction register	P5DDR	W	H'F8	H'FFB8
Port 5 data register	P5DR	R/W	H'F8	H'FFBA

Port 5 Data Direction Register (P5DDR)

	7	6	5	4	3	2	1	0
Bit	—	—	—	—	—	P5 ₂ DDR	P5 ₁ DDR	P5 ₀ DDR
Initial value	1	1	1	1	1	0	0	0
Read/Write	—	—	—	—	—	W	W	W

P5DDR is an 8-bit register that controls the input/output direction of each pin in port 5. A pin functions as an output pin if the corresponding P5DDR bit is set to 1, and as an input pin if this bit is cleared to 0.

P5DDR is a write-only register. Read data is invalid. If read, all bits always read 1.

P5DDR is initialized to H'F8 by a reset and in hardware standby mode. In software standby mode it retains its existing values, so if a transition to software standby mode occurs while a P5DDR bit is set to 1, the corresponding pin remains in the output state.

If a transition to software standby mode occurs while port 5 is being used by the SCI, the SCI will be initialized, so the pin will revert to general-purpose input/output, controlled by P5DDR and P5DR.

Port 5 Data Register (P5DR)

	7	6	5	4	3	2	1	0
Bit	—	—	—	—	—	P5 ₂	P5 ₁	P5 ₀
Initial value	1	1	1	1	1	0	0	0
Read/Write	—	—	—	—	—	R/W	R/W	R/W

P5DR is an 8-bit register that stores data for pins P5₂ to P5₀. Bits 7 to 3 are reserved. They cannot be modified, and are always read as 1.

When a P5DDR bit is set to 1, if port 5 is read, the value in P5DR is obtained directly, regardless of the actual pin state. When a P5DDR bit is cleared to 0, if port 5 is read the pin state is obtained. This also applies to pins used as SCI pins.

P5DR is initialized to H'F8 by a reset and in hardware standby mode. In software standby mode it retains its existing values.

7.6.3 Pin Functions

Port 5 has the same pin functions in each operating mode. All pins can also be used as SCI input/output pins. Table 7-11 indicates the pin functions of port 5.

Table 7-11 Port 5 Pin Functions

Pin	Pin Functions and Selection Method					
P5 ₂ /SCK	Bit C/ \bar{A} in SMR of SCI, bits CKE0 and CKE1 in SCR of SCI, and bit P5 ₂ DDR select the pin function as follows					
	CKE1	0			1	
	C/ \bar{A}	0		1	—	
	CKE0	0		1	—	—
	P5 ₂ DDR	0	1	—	—	—
	Pin function	P5 ₂ input	P5 ₂ output	SCK output	SCK output	SCK input
P5 ₁ /RxD	Bit RE in SCR of SCI and bit P5 ₁ DDR select the pin function as follows					
	RE	0			1	
	P5 ₁ DDR	0		1	—	
	Pin function	P5 ₁ input		P5 ₁ output		RxD input
P5 ₀ /TxD	Bit TE in SCR of SCI and bit P5 ₀ DDR select the pin function as follows					
	TE	0			1	
	P5 ₀ DDR	0		1	—	
	Pin function	P5 ₀ input		P5 ₀ output		TxD output

7.7 Port 6

7.7.1 Overview

Port 6 is an 8-bit input/output port that is multiplexed with input/output pins (FTOA, FTOB, FTIA to FTID, FTCl) of the 16-bit free-running timer (FRT) and with input/output pins (TMRI₀, TMRI₁, TMCI₀, TMCI₁, TMO₀, TMO₁) of 8-bit timers 0 and 1. The port 6 pin functions are the same in all operating modes. Figure 7-14 shows the pin configuration of port 6.

Pins in port 6 can drive one TTL load and a 90-pF capacitive load. They can also drive a darlington pair.

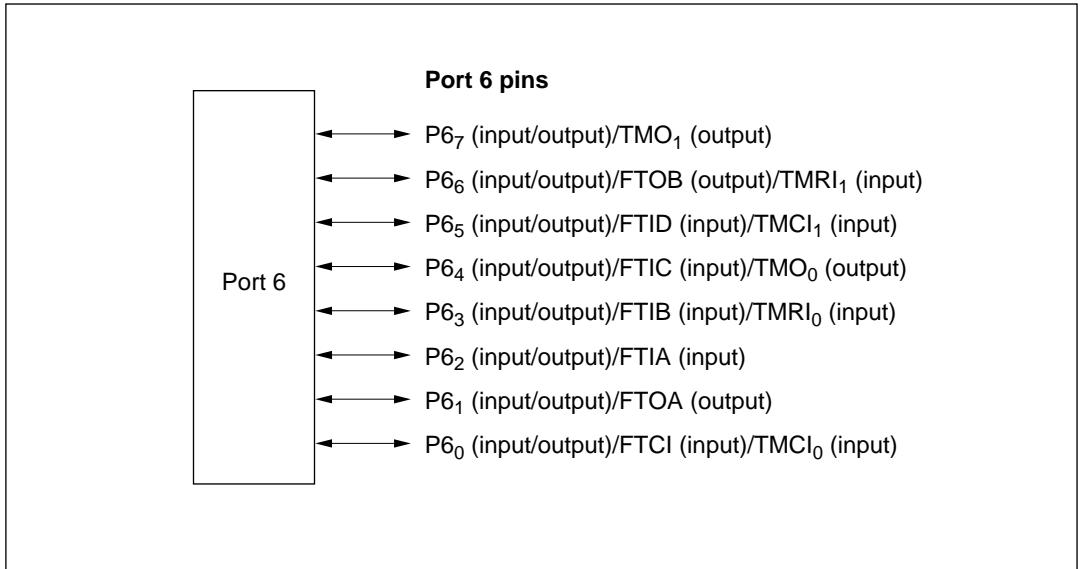

Figure 7-14 Port 6 Pin Configuration

7.7.2 Register Configuration and Descriptions

Table 7-12 summarizes the port 6 registers.

Table 7-12 Port 6 Registers

Name	Abbreviation	Read/Write	Initial Value	Address
Port 6 data direction register	P6DDR	W	H'00	H'FFB9
Port 6 data register	P6DR	R/W	H'00	H'FFBB

Port 6 Data Direction Register (P6DDR)

Bit	7	6	5	4	3	2	1	0
	P6 ₇ DDR	P6 ₆ DDR	P6 ₅ DDR	P6 ₄ DDR	P6 ₃ DDR	P6 ₂ DDR	P6 ₁ DDR	P6 ₀ DDR
Initial value	0	0	0	0	0	0	0	0
Read/Write	W	W	W	W	W	W	W	W

P6DDR is an 8-bit readable/writable register that controls the input/output direction of each pin in port 6. A pin functions as an output pin if the corresponding P6DDR bit is set to 1, and as an input pin if this bit is cleared to 0.

P6DDR is a write-only register. Read data is invalid. If read, all bits always read 1.

P6DDR is initialized to H'00 by a reset and in hardware standby mode. In software standby mode it retains its existing values, so if a transition to software standby mode occurs while a P6DDR bit is set to 1, the corresponding pin remains in the output state.

If a transition to software standby mode occurs while port 6 is being used by an on-chip supporting module (for example, for 8-bit timer output), the on-chip supporting module will be initialized, so the pin will revert to general-purpose input/output, controlled by P6DDR and P6DR.

Port 6 Data Register (P6DR)

Bit	7	6	5	4	3	2	1	0
	P6 ₇	P6 ₆	P6 ₅	P6 ₄	P6 ₃	P6 ₂	P6 ₁	P6 ₀
Initial value	0	0	0	0	0	0	0	0
Read/Write	R/W	R/W	R/W	R/W	R/W	R/W	R/W	R/W

P6DR is an 8-bit register that stores data for pins P6₇ to P6₀. When a P6DDR bit is set to 1, if port 6 is read, the value in P6DR is obtained directly, regardless of the actual pin state. When a P6DDR bit is cleared to 0, if port 6 is read the pin state is obtained. This also applies to pins used by on-chip supporting modules.

P6DR is initialized to H'00 by a reset and in hardware standby mode. In software standby mode it retains its existing values.

7.7.3 Pin Functions

Port 6 has the same pin functions all operating modes. The pins are multiplexed with FRT input/output, and 8-bit timer input/output. Table 7-13 indicates the pin functions of port 6.

Table 7-13 Port 6 Pin Functions

Pin	Pin Functions and Selection Method			
P6 ₇ /TMO ₁	Bits OS3 to OS0 in TCSR of 8-bit timer 1, and bit P6 ₇ DDR, select the pin function as follows			
	OS3 to 0	All 0		Not all 0
	P6 ₇ DDR	0	1	—
	Pin function	P6 ₇ input	P6 ₇ output	TMO ₁ output
P6 ₆ /FTOB/ TMRI ₁	Bit OEB in TOCR of the FRT and bit P6 ₆ DDR select the pin function as follows			
	OEB	0		1
	P6 ₆ DDR	0	1	0 1
	Pin function	P6 ₆ input	P6 ₆ output	FTOB output
TMRI ₁ input				
TMRI ₁ input is usable when bits CCLR1 and CCLR0 are both set to 1 in TCR of 8-bit timer 1				
P6 ₅ /FTID/ TMCI ₁	P6 ₅ DDR	0		1
	Pin function	P6 ₅ input		P6 ₅ output
		FTID input or TMCI ₁ input		
	TMCI ₁ input is usable when bits CKS2 to CKS0 in TCR of 8-bit timer 1 select an external clock source			
P6 ₄ /FTIC/ TMO ₀	Bits OS3 to OS0 in TCSR of 8-bit timer 0 and bit P6 ₄ DDR select the pin function as follows			
	OS3 to 0	All 0		Not all 0
	P6 ₄ DDR	0	1	0 1
	Pin function	P6 ₄ input	P6 ₄ output	TMO ₀ output
FTIC input				

Table 7-13 Port 6 Pin Functions (cont)**Pin Pin Functions and Selection Method**P6₃/FTIB/
TMR₁₀

P6 ₃ DDR	0	1
Pin function	P6 ₃ input	P6 ₃ output
	FTIB input or TMR ₁₀ input	

TMR₁₀ input is usable when bits CCLR1 and CCLR0 are both set to 1 in TCR of 8-bit timer 0

P6₂/FTIA

P6 ₂ DDR	0	1
Pin function	P6 ₂ input	P6 ₂ output
	FTIA input	

P6₁/FTOABit OEA in TOCR of the FRT and bit P6₁DDR select the pin function as follows

OEA	0		1	
P6 ₁ DDR	0	1	0	1
Pin function	P6 ₁ input	P6 ₁ output	FTOA output	

P6₀/FTCI/
TMCI₀

P6 ₀ DDR	0	1
Pin function	P6 ₀ input	P6 ₀ output
	FTCI input or TMCI ₀ input	

FTCI input is usable when bits CKS1 and CKS0 in TCR of the FRT select an external clock source

TMCI₀ input is usable when bits CKS2 to CKS0 in TCR of 8-bit timer 0 select an external clock source

7.8 Port 7

7.8.1 Overview

Port 7 is an 8-bit input port that also provides the analog input pins for the A/D converter. The pin functions are the same in all modes. Figure 7-15 shows the pin configuration of port 7.

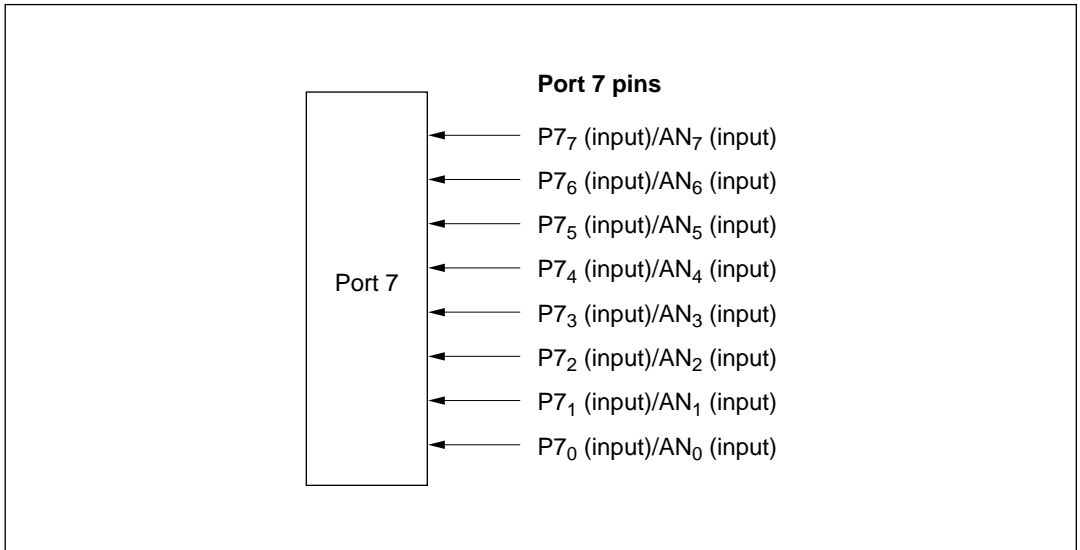

Figure 7-15 Port 7 Pin Configuration

7.8.2 Register Configuration and Descriptions

Table 7-14 summarizes the port 7 registers. Port 7 is an input port, so there is no data direction register.

Table 7-14 Port 7 Register

Name	Abbreviation	Read/Write	Initial Value	Address
Port 7 input register	P7PIN	R	Undetermined	H'FFBE

Port 7 Input Register (P7PIN)

Bit	7	6	5	4	3	2	1	0
	P7 ₇	P7 ₆	P7 ₅	P7 ₄	P7 ₃	P7 ₂	P7 ₁	P7 ₀
Initial value	—*	—*	—*	—*	—*	—*	—*	—*
Read/Write	R	R	R	R	R	R	R	R

Note: * Depends on the levels of pins P7₇ to P7₀.

When P7PIN is read, the pin states are always read. P7PIN is a read-only register and cannot be written to.

Section 8 16-Bit Free-Running Timer

8.1 Overview

The H8/3297 Series has an on-chip 16-bit free-running timer (FRT) module that uses a 16-bit free-running counter as a time base. Applications of the FRT module include rectangular-wave output (up to two independent waveforms), input pulse width measurement, and measurement of external clock periods.

8.1.1 Features

The features of the free-running timer module are listed below.

- Selection of four clock sources

The free-running counter can be driven by an internal clock source ($\phi_P/2$, $\phi_P/8$, or $\phi_P/32$), or an external clock input (enabling use as an external event counter).

- Two independent comparators

Each comparator can generate an independent waveform.

- Four input capture channels

The current count can be captured on the rising or falling edge (selectable) of an input signal. The four input capture registers can be used separately, or in a buffer mode.

- Counter can be cleared under program control

The free-running counters can be cleared on compare-match A.

- Seven independent interrupts

Compare-match A and B, input capture A to D, and overflow interrupts are requested independently.

8.1.2 Block Diagram

Figure 8-1 shows a block diagram of the free-running timer.

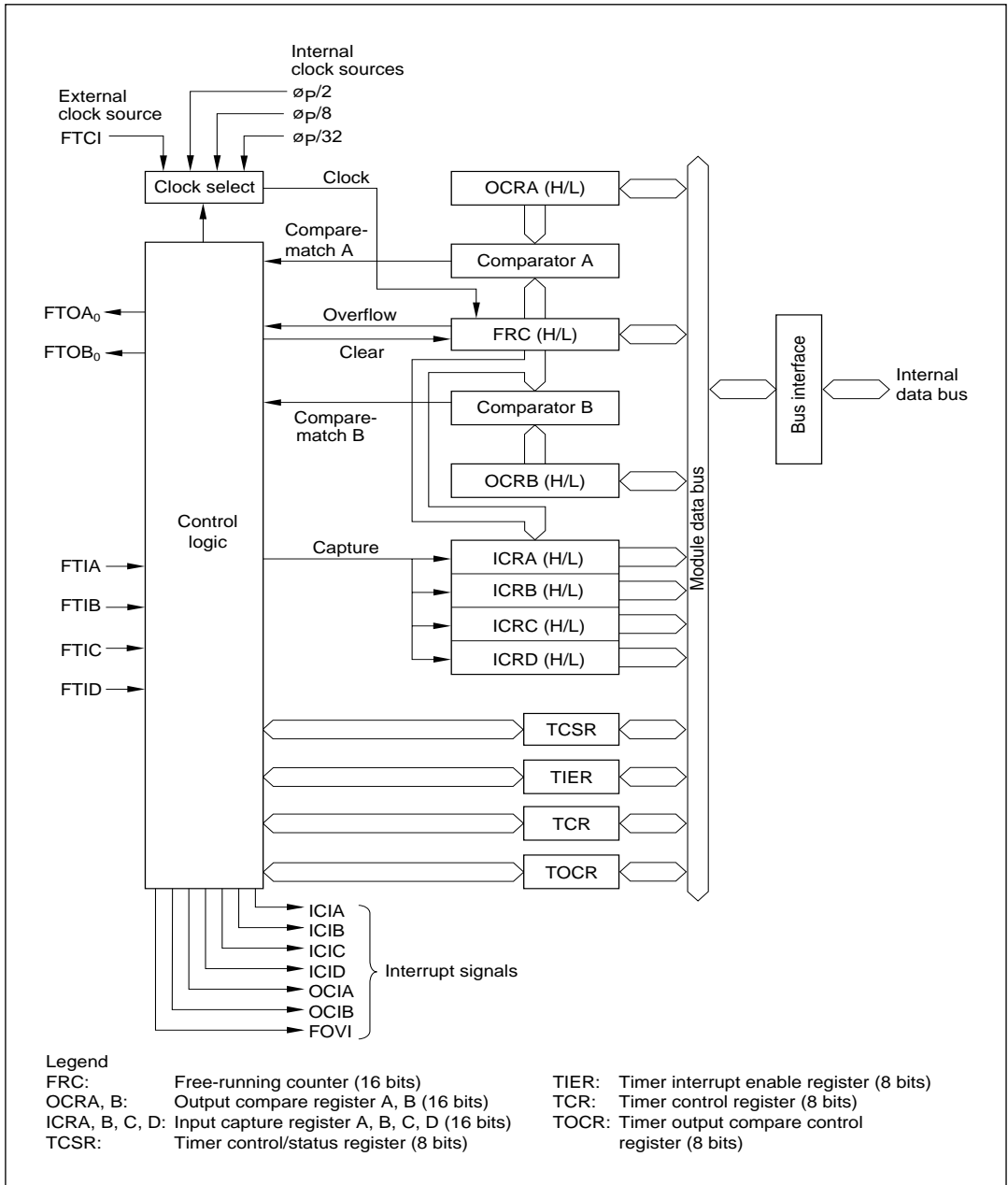

Figure 8-1 Block Diagram of 16-Bit Free-Running Timer

8.1.3 Input and Output Pins

Table 8-1 lists the input and output pins of the free-running timer module.

Table 8-1 Input and Output Pins of Free-Running Timer Module

Name	Abbreviation	I/O	Function
Counter clock input	FTCI	Input	Input of external free-running counter clock signal
Output compare A	FTOA	Output	Output controlled by comparator A
Output compare B	FTOB	Output	Output controlled by comparator B
Input capture A	FTIA	Input	Trigger for capturing current count into input capture register A
Input capture B	FTIB	Input	Trigger for capturing current count into input capture register B
Input capture C	FTIC	Input	Trigger for capturing current count into input capture register C
Input capture D	FTID	Input	Trigger for capturing current count into input capture register D

8.1.4 Register Configuration

Table 8-2 lists the registers of the free-running timer module.

Table 8-2 Register Configuration

Name	Abbreviation	R/W	Initial Value	Address
Timer interrupt enable register	TIER	R/W	H'01	H'FF90
Timer control/status register	TCSR	R/(W)*1	H'00	H'FF91
Free-running counter (high)	FRC (H)	R/W	H'00	H'FF92
Free-running counter (low)	FRC (L)	R/W	H'00	H'FF93
Output compare register A/B (high)*2	OCRA/B (H)	R/W	H'FF	H'FF94*2
Output compare register A/B (low)*2	OCRA/B (L)	R/W	H'FF	H'FF95*2
Timer control register	TCR	R/W	H'00	H'FF96
Timer output compare control register	TOCR	R/W	H'E0	H'FF97
Input capture register A (high)	ICRA (H)	R	H'00	H'FF98
Input capture register A (low)	ICRA (L)	R	H'00	H'FF99

- Notes: 1. Software can write a 0 to clear bits 7 to 1, but cannot write a 1 in these bits.
2. OCRA and OCRB share the same addresses. Access is controlled by the OCRS bit in TOCR.

Table 8-2 Register Configuration (cont.)

Name	Abbreviation	R/W	Initial Value	Address
Input capture register B (high)	ICRB (H)	R	H'00	H'FF9A
Input capture register B (low)	ICRB (L)	R	H'00	H'FF9B
Input capture register C (high)	ICRC (H)	R	H'00	H'FF9C
Input capture register C (low)	ICRC (L)	R	H'00	H'FF9D
Input capture register D (high)	ICRD (H)	R	H'00	H'FF9E
Input capture register D (low)	ICRD (L)	R	H'00	H'FF9F

8.2 Register Descriptions

8.2.1 Free-Running Counter (FRC)

Bit	15	14	13	12	11	10	9	8	7	6	5	4	3	2	1	0
	<input type="checkbox"/>	<input type="checkbox"/>	<input type="checkbox"/>	<input type="checkbox"/>	<input type="checkbox"/>	<input type="checkbox"/>	<input type="checkbox"/>	<input type="checkbox"/>	<input type="checkbox"/>	<input type="checkbox"/>	<input type="checkbox"/>	<input type="checkbox"/>	<input type="checkbox"/>	<input type="checkbox"/>	<input type="checkbox"/>	<input type="checkbox"/>
Initial value	0	0	0	0	0	0	0	0	0	0	0	0	0	0	0	0
Read/Write	R/W	R/W	R/W	R/W	R/W	R/W	R/W	R/W	R/W	R/W	R/W	R/W	R/W	R/W	R/W	R/W

FRC is a 16-bit readable/writable up-counter that increments on an internal pulse generated from a clock source. The clock source is selected by the clock select 1 and 0 bits (CKS1 and CKS0) of the timer control register (TCR).

When FRC overflows from H'FFFF to H'0000, the overflow flag (OVF) in the timer control/status register (TCSR) is set to 1.

Because FRC is a 16-bit register, a temporary register (TEMP) is used when FRC is written or read. See section 8.3, CPU Interface, for details.

FRC is initialized to H'0000 at a reset and in the standby modes. It can also be cleared by compare-match A.

8.2.2 Output Compare Registers A and B (OCRA and OCRB)

Bit	15	14	13	12	11	10	9	8	7	6	5	4	3	2	1	0
Initial value	1	1	1	1	1	1	1	1	1	1	1	1	1	1	1	1
Read/Write	R/W	R/W	R/W	R/W	R/W	R/W	R/W	R/W	R/W	R/W	R/W	R/W	R/W	R/W	R/W	R/W

OCRA and OCRB are 16-bit readable/writable registers, the contents of which are continually compared with the value in the FRC. When a match is detected, the corresponding output compare flag (OCFA or OCFB) is set in the timer control/status register (TCSR).

In addition, if the output enable bit (OEA or OEB) in the timer output compare control register (TOCR) is set to 1, when the output compare register and FRC values match, the logic level selected by the output level bit (OLVLA or OLVLB) in TOCR is output at the output compare pin (FTOA or FTOB). Following a reset, the FTOA and FTOB output levels are 0 until the first compare-match.

OCRA and OCRB share the same address. They are differentiated by the OCRS bit in TOCR. A temporary register (TEMP) is used for write access, as explained in section 8.3, CPU Interface.

OCRA and OCRB are initialized to H'FFFF at a reset and in the standby modes.

8.2.3 Input Capture Registers A to D (ICRA to ICRD)

Bit	15	14	13	12	11	10	9	8	7	6	5	4	3	2	1	0
Initial value	0	0	0	0	0	0	0	0	0	0	0	0	0	0	0	0
Read/Write	R	R	R	R	R	R	R	R	R	R	R	R	R	R	R	R

There are four input capture registers A to D, each of which is a 16-bit read-only register.

When the rising or falling edge of the signal at an input capture pin (FTIA to FTID) is detected, the current FRC value is copied to the corresponding input capture register (ICRA to ICRD).* At the same time, the corresponding input capture flag (ICFA to ICFD) in the timer control/status register (TCSR) is set to 1. The input capture edge is selected by the input edge select bits (IEDGA to IEDGD) in the timer control register (TCR).

Note: * The FRC contents are transferred to the input capture register regardless of the value of the input capture flag (ICFA/B/C/D).

Input capture can be buffered by using the input capture registers in pairs. When the BUFEA bit in TCR is set to 1, ICRC is used as a buffer register for ICRA as shown in figure 8-2. When an FTIA input is received, the old ICRA contents are moved into ICRC, and the new FRC count is copied into ICRA.

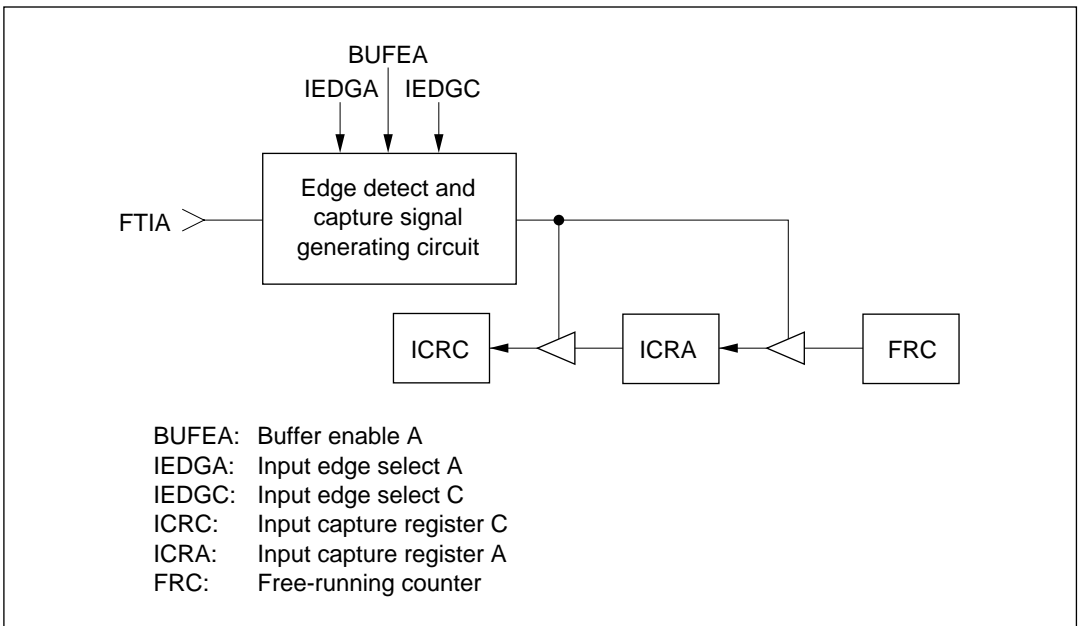

Figure 8-2 Input Capture Buffering

Similarly, when the BUFEB bit in TCR is set to 1, ICRD is used as a buffer register for ICRB.

When input capture is buffered, if the two input edge bits are set to different values (IEDGA ≠ IEDGC or IEDGB ≠ IEDGD), then input capture is triggered on both the rising and falling edges of the FTIA or FTIB input signal. If the two input edge bits are set to the same value (IEDGA = IEDGC or IEDGB = IEDGD), then input capture is triggered on only one edge. See table 8-3.

Table 8-3 Buffered Input Capture Edge Selection (Example)

IEDGA	IEDGC	Input Capture Edge
0	0	Captured on falling edge of input capture A (FTIA) (Initial value)
0	1	Captured on both rising and falling edges of input capture A (FTIA)
1	0	
1	1	Captured on rising edge of input capture A (FTIA)

Because the input capture registers are 16-bit registers, a temporary register (TEMP) is used when they are read. See section 8.3, CPU Interface, for details.

To ensure input capture, the width of the input capture pulse should be at least 1.5 system clock periods (1.5·ϕ). When triggering is enabled on both edges, the input capture pulse width should be at least 2.5 system clock periods.

The input capture registers are initialized to H'0000 at a reset and in the standby modes.

8.2.4 Timer Interrupt Enable Register (TIER)

Bit	7	6	5	4	3	2	1	0
	ICIAE	ICIBE	ICICE	ICIDE	OCIAE	OCIBE	OVIE	—
Initial value	0	0	0	0	0	0	0	1
Read/Write	R/W	R/W	R/W	R/W	R/W	R/W	R/W	—

The TIER is an 8-bit readable/writable register that enables and disables interrupts.

The TIER is initialized to H'01 at a reset and in the standby modes.

Bit 7—Input Capture Interrupt A Enable (ICIAE): This bit selects whether to request input capture interrupt A (ICIA) when input capture flag A (ICFA) in the timer status/control register (TCSR) is set to 1.

Bit 7

ICIAE	Description
0	Input capture interrupt request A (ICIA) is disabled. (Initial value)
1	Input capture interrupt request A (ICIA) is enabled.

Bit 6—Input Capture Interrupt B Enable (ICIBE): This bit selects whether to request input capture interrupt B (ICIB) when input capture flag B (ICFB) in TCSR is set to 1.

Bit 6

ICIBE	Description
0	Input capture interrupt request B (ICIB) is disabled. (Initial value)
1	Input capture interrupt request B (ICIB) is enabled.

Bit 5—Input Capture Interrupt C Enable (ICICE): This bit selects whether to request input capture interrupt C (ICIC) when input capture flag C (ICFC) in TCSR is set to 1.

Bit 5

ICICE	Description
0	Input capture interrupt request C (ICIC) is disabled. (Initial value)
1	Input capture interrupt request C (ICIC) is enabled.

Bit 4—Input Capture Interrupt D Enable (ICIDE): This bit selects whether to request input capture interrupt D (ICID) when input capture flag D (ICFD) in TCSR is set to 1.

Bit 4

ICIDE	Description
0	Input capture interrupt request D (ICID) is disabled. (Initial value)
1	Input capture interrupt request D (ICID) is enabled.

Bit 3—Output Compare Interrupt A Enable (OCIAE): This bit selects whether to request output compare interrupt A (OCIA) when output compare flag A (OCFA) in TCSR is set to 1.

Bit 3

OCIAE	Description
0	Output compare interrupt request A (OCIA) is disabled. (Initial value)
1	Output compare interrupt request A (OCIA) is enabled.

Bit 2—Output Compare Interrupt B Enable (OCIBE): This bit selects whether to request output compare interrupt B (OCIB) when output compare flag B (OCFB) in TCSR is set to 1.

Bit 2

OCIBE	Description
0	Output compare interrupt request B (OCIB) is disabled. (Initial value)
1	Output compare interrupt request B (OCIB) is enabled.

Bit 1—Timer Overflow Interrupt Enable (OVIE): This bit selects whether to request a free-running timer overflow interrupt (FOVI) when the timer overflow flag (OVF) in TCSR is set to 1.

Bit 1

OVIE	Description
0	Timer overflow interrupt request (FOVI) is disabled. (Initial value)
1	Timer overflow interrupt request (FOVI) is enabled.

Bit 0—Reserved: This bit cannot be modified and is always read as 1.

8.2.5 Timer Control/Status Register (TCSR)

Bit	7	6	5	4	3	2	1	0
	ICFA	ICFB	ICFC	ICFD	OCFA	OCFB	OVF	OCLRA
Initial value	0	0	0	0	0	0	0	0
Read/Write	R/(W)*	R/(W)*	R/(W)*	R/(W)*	R/(W)*	R/(W)*	R/(W)*	R/W

Note: * Software can write a 0 in bits 7 to 1 to clear the flags, but cannot write a 1 in these bits.

TCSR is an 8-bit readable and partially writable* register that contains the seven interrupt flags and specifies whether to clear the counter on compare-match A (when the FRC and OCRA values match).

TCSR is initialized to H'00 at a reset and in the standby modes.

Timing is described in section 8.4, Operation.

Bit 7—Input Capture Flag A (ICFA): This status bit is set to 1 to flag an input capture A event. If BUFEA = 0, ICFA indicates that the FRC value has been copied to ICRA. If BUFEA = 1, ICFA indicates that the old ICRA value has been moved into ICRC and the new FRC value has been copied to ICRA.

ICFA must be cleared by software. It is set by hardware, however, and cannot be set by software.

Bit 7

ICFA	Description
0	To clear ICFA, the CPU must read ICFA after it has been set to 1, then write a 0 in this bit. (Initial value)
1	This bit is set to 1 when an FTIA input signal causes the FRC value to be copied to ICRA.

Bit 6—Input Capture Flag B (ICFB): This status bit is set to 1 to flag an input capture B event. If BUFEA = 0, ICFB indicates that the FRC value has been copied to ICRB. If BUFEA = 1, ICFB indicates that the old ICRB value has been moved into ICRD and the new FRC value has been copied to ICRB.

ICFB must be cleared by software. It is set by hardware, however, and cannot be set by software.

Bit 6

ICFB	Description
0	To clear ICFB, the CPU must read ICFB after it has been set to 1, then write a 0 in this bit. (Initial value)
1	This bit is set to 1 when an FTIB input signal causes the FRC value to be copied to ICRB.

Bit 5—Input Capture Flag C (ICFC): This status bit is set to 1 to flag input of a rising or falling edge of FTIC as selected by the IEDGC bit. When BUFEA = 0, this indicates capture of the FRC count in ICRC. When BUFEA = 1, however, the FRC count is not captured, so ICFC becomes simply an external interrupt flag. In other words, the buffer mode frees FTIC for use as a general-purpose interrupt signal (which can be enabled or disabled by the ICICE bit).

ICFC must be cleared by software. It is set by hardware, however, and cannot be set by software.

Bit 5

ICFC	Description
0	To clear ICFC, the CPU must read ICFC after it has been set to 1, then write a 0 in this bit. (Initial value)
1	This bit is set to 1 when an FTIC input signal is received.

Bit 4—Input Capture Flag D (ICFD): This status bit is set to 1 to flag input of a rising or falling edge of FTID as selected by the IEDGD bit. When BUFEA = 0, this indicates capture of the FRC count in ICRD. When BUFEA = 1, however, the FRC count is not captured, so ICFD becomes simply an external interrupt flag. In other words, the buffer mode frees FTID for use as a general-purpose interrupt signal (which can be enabled or disabled by the ICIDE bit).

ICFD must be cleared by software. It is set by hardware, however, and cannot be set by software.

Bit 4

ICFD	Description
0	To clear ICFD, the CPU must read ICFD after it has been set to 1, then write a 0 in this bit. (Initial value)
1	This bit is set to 1 when an FTID input signal is received.

Bit 3—Output Compare Flag A (OCFA): This status flag is set to 1 when the FRC value matches the OCRA value. This flag must be cleared by software. It is set by hardware, however, and cannot be set by software.

Bit 3

OCFA	Description
0	To clear OCFA, the CPU must read OCFA after it has been set to 1, then write a 0 in this bit. (Initial value)
1	This bit is set to 1 when FRC = OCRA.

Bit 2—Output Compare Flag B (OCFB): This status flag is set to 1 when the FRC value matches the OCRB value. This flag must be cleared by software. It is set by hardware, however, and cannot be set by software.

Bit 2

OCFB	Description
0	To clear OCFB, the CPU must read OCFB after it has been set to 1, then write a 0 in this bit. (Initial value)
1	This bit is set to 1 when FRC = OCRB.

Bit 1—Timer Overflow Flag (OVF): This status flag is set to 1 when the FRC overflows (changes from H'FFFF to H'0000). This flag must be cleared by software. It is set by hardware, however, and cannot be set by software.

Bit 1

OVF	Description
0	To clear OVF, the CPU must read OVF after it has been set to 1, then write a 0 in this bit. (Initial value)
1	This bit is set to 1 when FRC changes from H'FFFF to H'0000.

Bit 0—Counter Clear A (CCLRA): This bit selects whether to clear the FRC at compare-match A (when the FRC and OCRA values match).

Bit 0

CCLRA	Description
0	The FRC is not cleared. (Initial value)
1	The FRC is cleared at compare-match A.

8.2.6 Timer Control Register (TCR)

Bit	7	6	5	4	3	2	1	0
	IEDGA	IEDGB	IEDGC	IEDGD	BUFEA	BUFEB	CKS1	CKS0
Initial value	0	0	0	0	0	0	0	0
Read/Write	R/W	R/W	R/W	R/W	R/W	R/W	R/W	R/W

TCR is an 8-bit readable/writable register that selects the rising or falling edge of the input capture signals, enables the input capture buffer mode, and selects the FRC clock source.

TCR is initialized to H'00 at a reset and in the standby modes.

Bit 7—Input Edge Select A (IEDGA): This bit selects the rising or falling edge of the input capture A signal (FTIA).

Bit 7 IEDGA	Description
0	Input capture A events are recognized on the falling edge of FTIA. (Initial value)
1	Input capture A events are recognized on the rising edge of FTIA.

Bit 6—Input Edge Select B (IEDGB): This bit selects the rising or falling edge of the input capture B signal (FTIB).

Bit 6 IEDGB	Description
0	Input capture B events are recognized on the falling edge of FTIB. (Initial value)
1	Input capture B events are recognized on the rising edge of FTIB.

Bit 5—Input Edge Select C (IEDGC): This bit selects the rising or falling edge of the input capture C signal (FTIC).

Bit 5 IEDGC	Description
0	Input capture C events are recognized on the falling edge of FTIC. (Initial value)
1	Input capture C events are recognized on the rising edge of FTIC.

Bit 4—Input Edge Select D (IEDGD): This bit selects the rising or falling edge of the input capture D signal (FTID).

Bit 4 IEDGD	Description
0	Input capture D events are recognized on the falling edge of FTID. (Initial value)
1	Input capture D events are recognized on the rising edge of FTID.

Bit 3—Buffer Enable A (BUFEA): This bit selects whether to use ICRC as a buffer register for ICRA.

Bit 3 BUFEA	Description
0	ICRC is used for input capture C. (Initial value)
1	ICRC is used as a buffer register for input capture A.

Bit 2—Buffer Enable B (BUFEB): This bit selects whether to use ICRD as a buffer register for ICRB.

Bit 2 BUFEB	Description	
0	ICRD is used for input capture D.	(Initial value)
1	ICRD is used as a buffer register for input capture B.	

Bits 1 and 0—Clock Select (CKS1 and CKS0): These bits select external clock input or one of three internal clock sources for FRC. External clock pulses are counted on the rising edge of signals input to pin FTCL.

Bit 1 CKS1	Bit 0 CKS0	Description	
0	0	$\phi_p/2$ internal clock source	(Initial value)
0	1	$\phi_p/8$ internal clock source	
1	0	$\phi_p/32$ internal clock source	
1	1	External clock source (rising edge)	

8.2.7 Timer Output Compare Control Register (TOCR)

Bit	7	6	5	4	3	2	1	0
	—	—	—	OCRS	OEA	OEB	OLVLA	OLVLB
Initial value	1	1	1	0	0	0	0	0
Read/Write	—	—	—	R/W	R/W	R/W	R/W	R/W

TOCR is an 8-bit readable/writable register that enables output from the output compare pins, selects the output levels, and switches access between output compare registers A and B.

TOCR is initialized to H'E0 at a reset and in the standby modes.

Bits 7 to 5—Reserved: These bits cannot be modified and are always read as 1.

Bit 4—Output Compare Register Select (OCRS): OCRA and OCRB share the same address. When this address is accessed, the OCRS bit selects which register is accessed. This bit does not affect the operation of OCRA or OCRB.

Bit 4 OCRS	Description	
0	OCRA is selected.	(Initial value)
1	OCRB is selected.	

Bit 3—Output Enable A (OEA): This bit enables or disables output of the output compare A signal (FTOA).

Bit 3 OEA	Description
0	Output compare A output is disabled. (Initial value)
1	Output compare A output is enabled.

Bit 2—Output Enable B (OEB): This bit enables or disables output of the output compare B signal (FTOB).

Bit 2 OEB	Description
0	Output compare B output is disabled. (Initial value)
1	Output compare B output is enabled.

Bit 1—Output Level A (OLVLA): This bit selects the logic level to be output at the FTOA pin when the FRC and OCRA values match.

Bit 1 OLVLA	Description
0	A 0 logic level is output for compare-match A. (Initial value)
1	A 1 logic level is output for compare-match A.

Bit 0—Output Level B (OLVLB): This bit selects the logic level to be output at the FTOB pin when the FRC and OCRB values match.

Bit 0 OLVLB	Description
0	A 0 logic level is output for compare-match B. (Initial value)
1	A 1 logic level is output for compare-match B.

8.3 CPU Interface

The free-running counter (FRC), output compare registers (OCRA and OCRB), and input capture registers (ICRA to ICRD) are 16-bit registers, but they are connected to an 8-bit data bus. When the CPU accesses these registers, to ensure that both bytes are written or read simultaneously, the access is performed using an 8-bit temporary register (TEMP).

These registers are written and read as follows:

- **Register Write**

When the CPU writes to the upper byte, the byte of write data is placed in TEMP. Next, when the CPU writes to the lower byte, this byte of data is combined with the byte in TEMP and all 16 bits are written in the register simultaneously.

- **Register Read**

When the CPU reads the upper byte, the upper byte of data is sent to the CPU and the lower byte is placed in TEMP. When the CPU reads the lower byte, it receives the value in TEMP.

Programs that access these registers should normally use word access. Equivalently, they may access first the upper byte, then the lower byte by two consecutive byte accesses. Data will not be transferred correctly if the bytes are accessed in reverse order, or if only one byte is accessed.

Figure 8-3 shows the data flow when FRC is accessed. The other registers are accessed in the same way. As an exception, when the CPU reads OCRA or OCRB, it reads both the upper and lower bytes directly, without using TEMP.

Coding Examples

To write the contents of general register R0 to OCRA: `MOV.W R0, @OCRA`

To transfer the contents of ICRA to general register R0: `MOV.W @ICRA, R0`

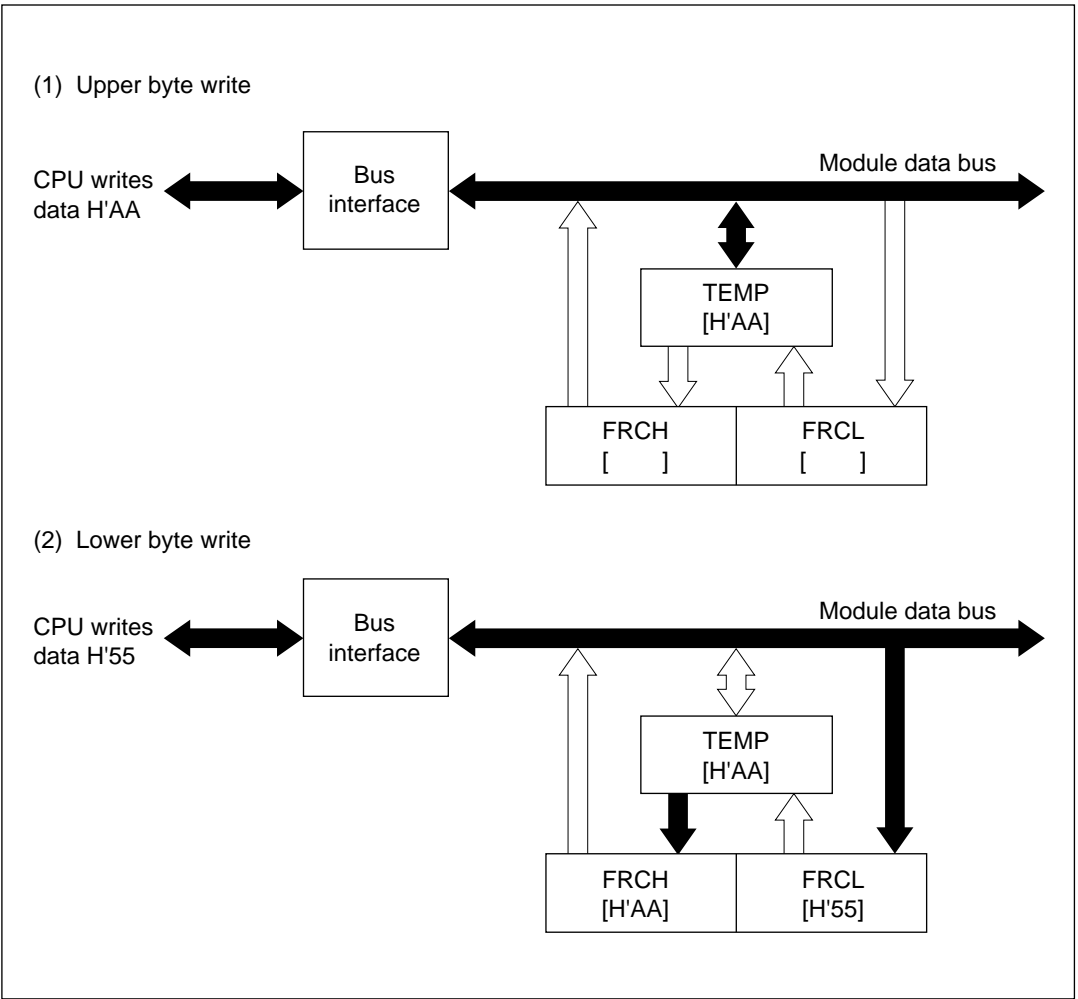
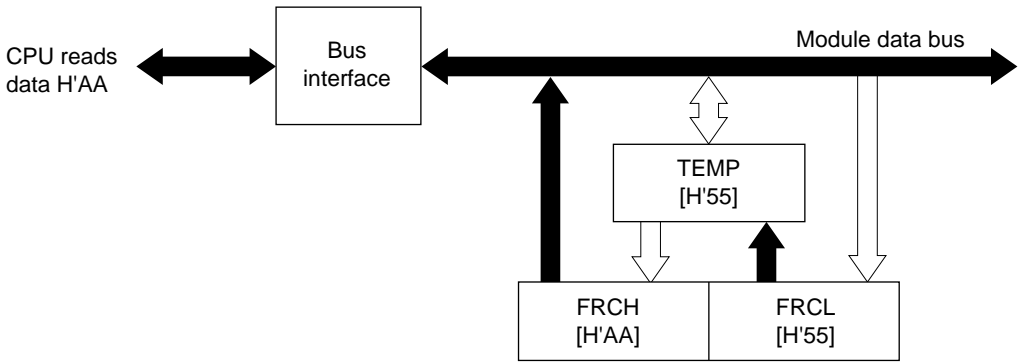

Figure 8-3 (a) Write Access to FRC (when CPU Writes H'AA55)

(1) Upper byte read



(2) Lower byte read

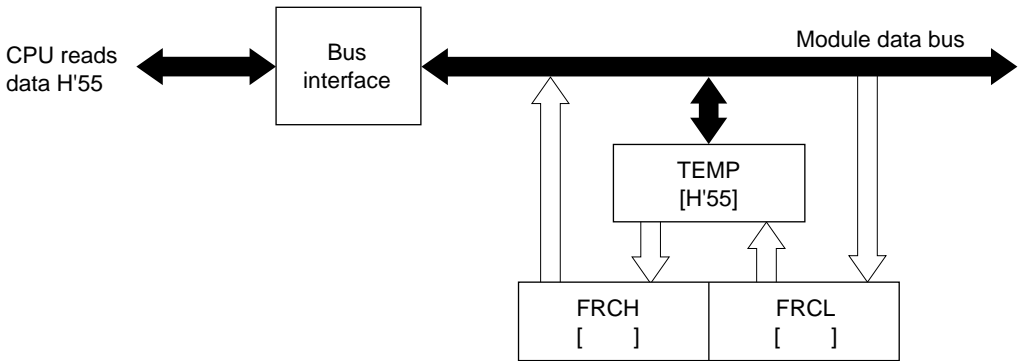

Figure 8-3 (b) Read Access to FRC (when FRC Contains H'AA55)

8.4 Operation

8.4.1 FRC Incrementation Timing

FRC increments on a pulse generated once for each period of the selected (internal or external) clock source. The clock source is selected by bits CKS0 and CKS1 in the TCR.

Internal Clock: The internal clock sources ($\phi_P/2$, $\phi_P/8$, $\phi_P/32$) are created from the system clock (ϕ) by a prescaler. FRC increments on a pulse generated from the falling edge of the prescaler output. See figure 8-4.

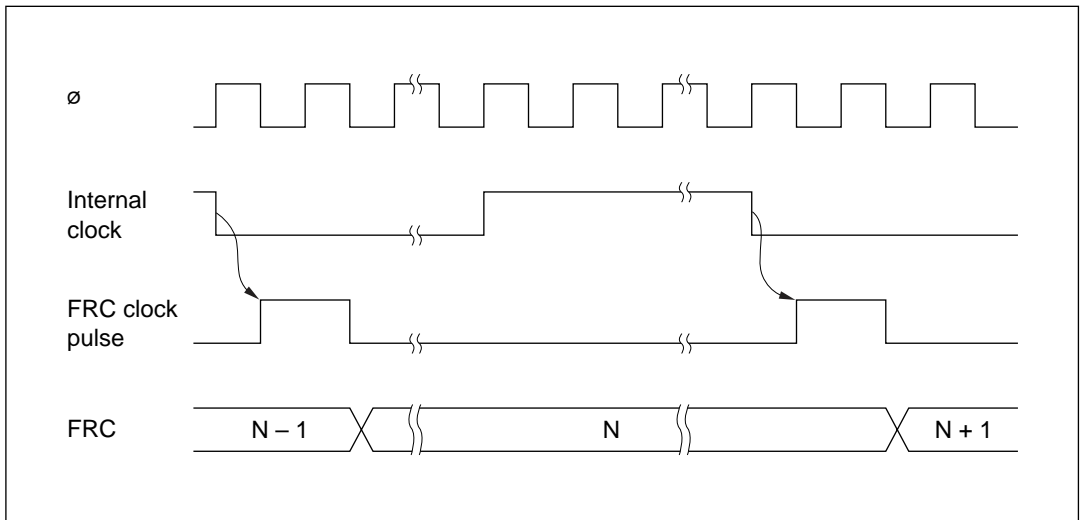

Figure 8-4 Increment Timing for Internal Clock Source

External Clock: If external clock input is selected, FRC increments on the rising edge of the FTCl clock signal. Figure 8-5 shows the increment timing.

The pulse width of the external clock signal must be at least 1.5 system clock (ϕ) periods. The counter will not increment correctly if the pulse width is shorter than 1.5 system clock periods.

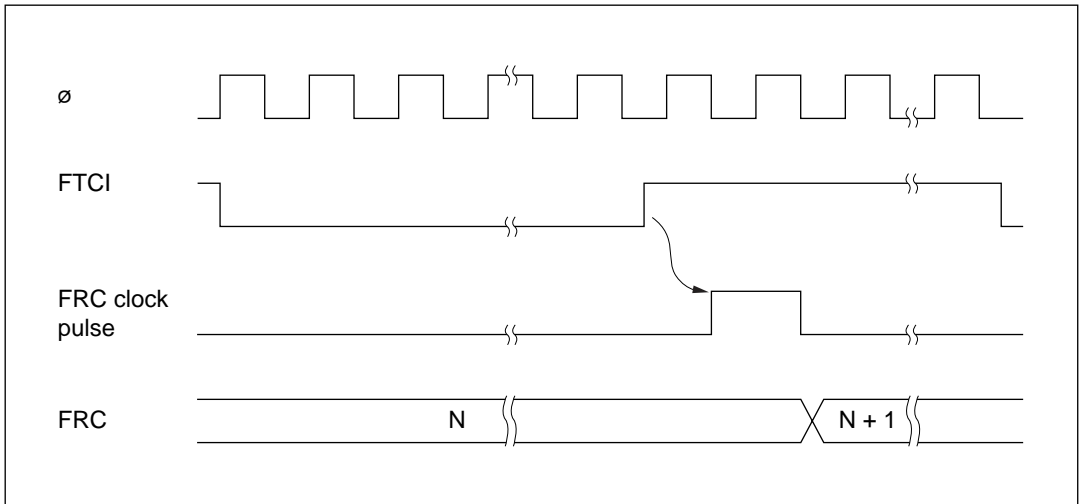

Figure 8-5 Increment Timing for External Clock Source

8.4.2 Output Compare Timing

When a compare-match occurs, the logic level selected by the output level bit (OLVLA or OLVLB) in TOCR is output at the output compare pin (FTOA or FTOB). Figure 8-6 shows the timing of this operation for compare-match A.

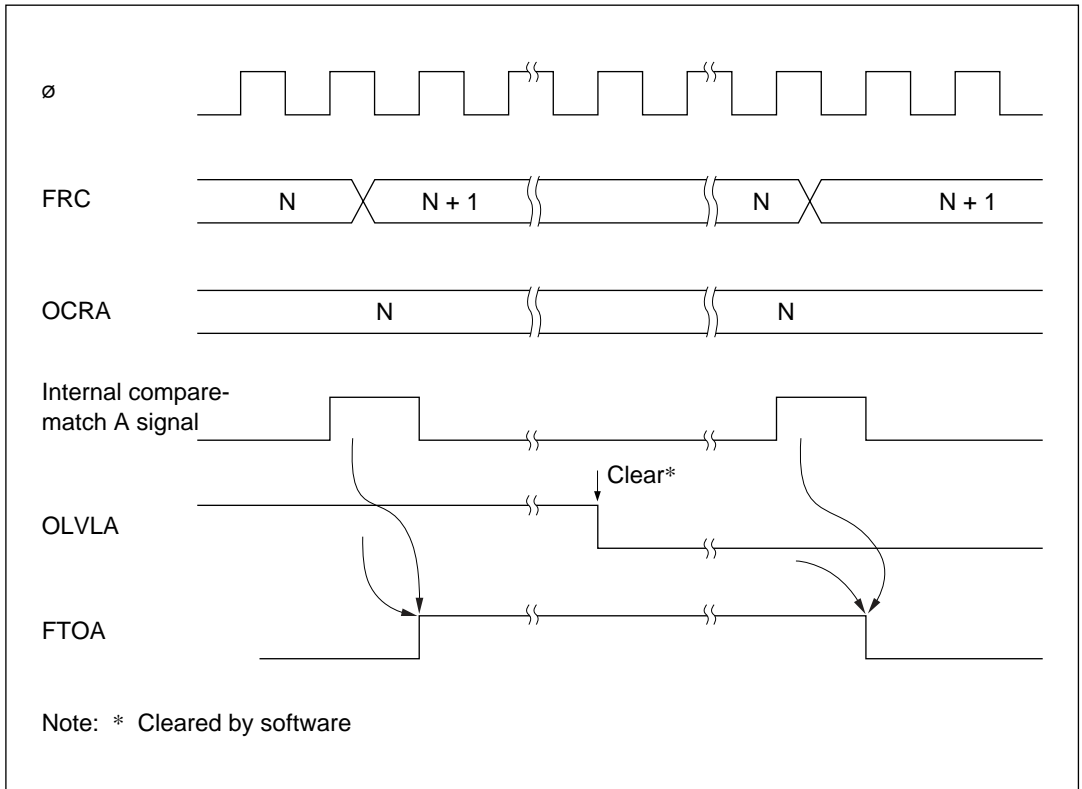

Figure 8-6 Timing of Output Compare A

8.4.3 FRC Clear Timing

If the CCLRA bit in TCSR is set to 1, the FRC is cleared when compare-match A occurs. Figure 8-7 shows the timing of this operation.

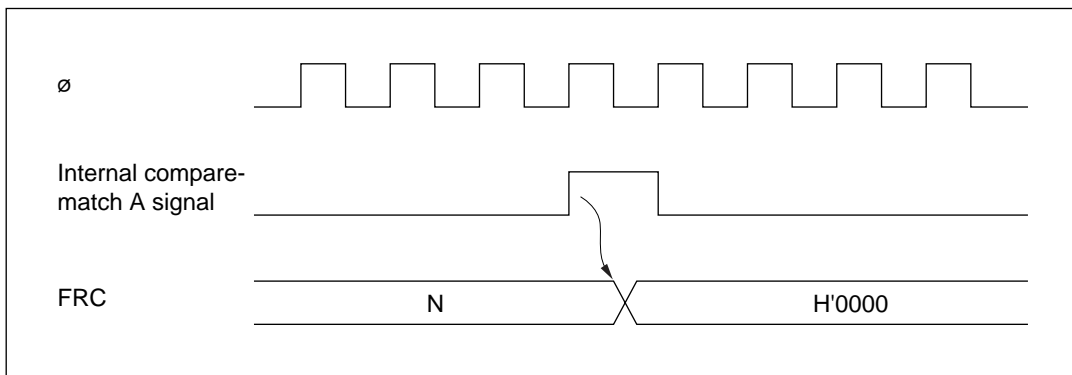

Figure 8-7 Clearing of FRC by Compare-Match A

8.4.4 Input Capture Timing

(1) **Input Capture Timing:** An internal input capture signal is generated from the rising or falling edge of the signal at the input capture pin FTIx ($x = A, B, C, D$), as selected by the corresponding IEDGx bit in TCR. Figure 8-8 shows the usual input capture timing when the rising edge is selected (IEDGx = 1).

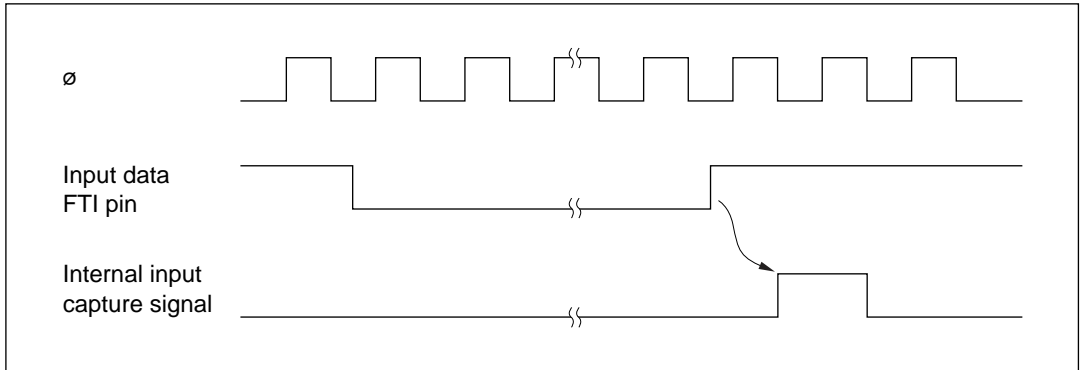

Figure 8-8 Input Capture Timing (Usual Case)

If the upper byte of ICRA/B/C/D is being read when the corresponding input capture signal arrives, the internal input capture signal is delayed by one state. Figure 8-9 shows the timing for this case.

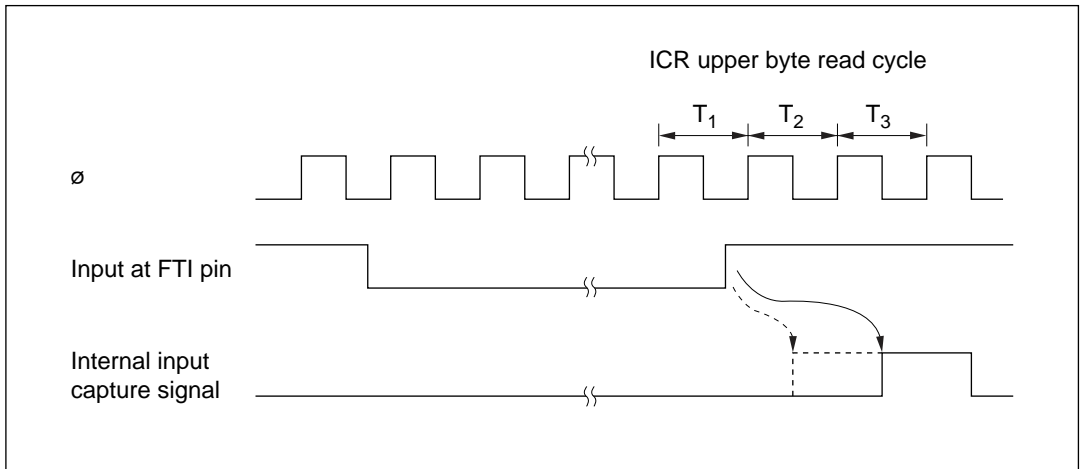

Figure 8-9 Input Capture Timing (1-State Delay Due to ICRA/B/C/D Read)

(2) Buffered Input Capture Timing: ICRC and ICRA can operate as buffers for ICRA and ICRB.

Figure 8-10 shows how input capture operates when ICRA and ICRC are used in buffer mode and IEDGA and IEDGC are set to different values (IEDGA = 0 and IEDGC = 1, or IEDG A = 1 and IEDGC = 0), so that input capture is performed on both the rising and falling edges of FTIA.

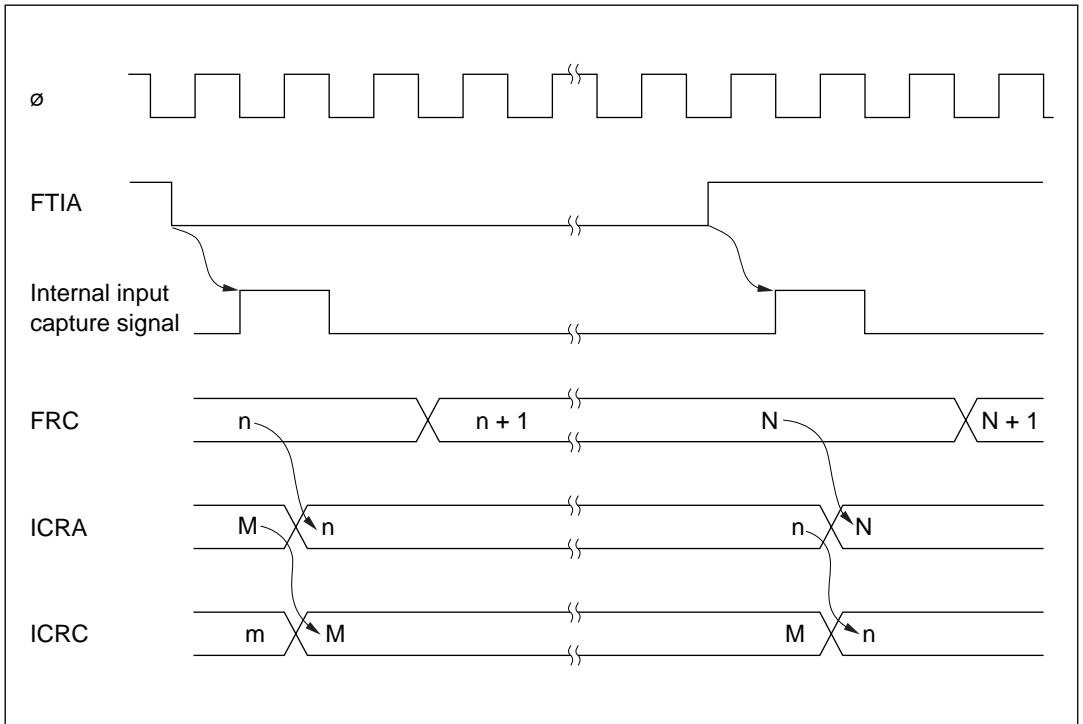

Figure 8-10 Buffered Input Capture with Both Edges Selected

When ICRC or ICRD is used as a buffer register, its input capture flag is set by the selected transition of its input capture signal. For example, if ICRC is used to buffer ICRA, when the edge transition selected by the IEDGC bit occurs on the FTIC input capture line, ICFC will be set, and if the ICIEC bit is set, an interrupt will be requested. The FRC value will not be transferred to ICRC, however.

In buffered input capture, if the upper byte of either of the two registers to which data will be transferred (ICRA and ICRC, or ICRB and ICRD) is being read when the input signal arrives, input capture is delayed by one system clock (ϕ). Figure 8-11 shows the timing when BUFEA = 1.

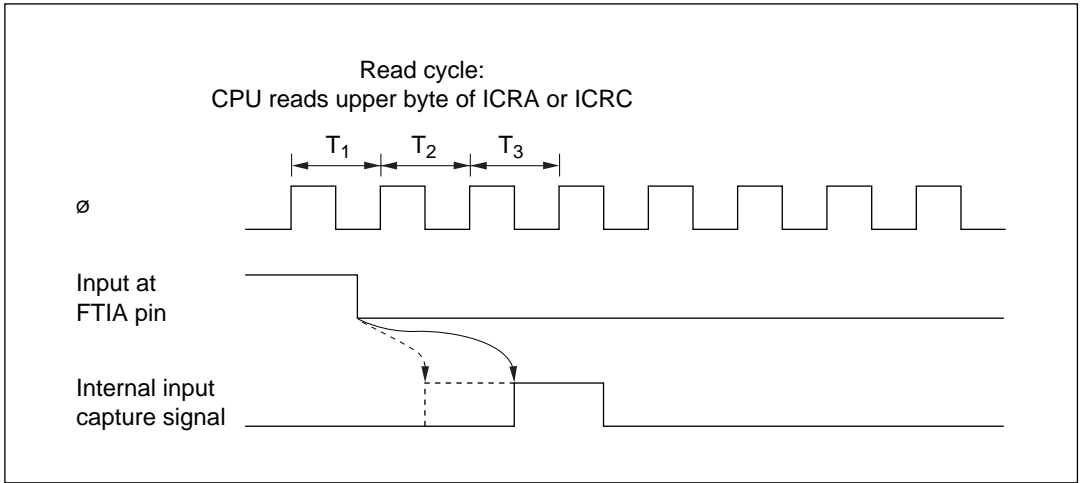

Figure 8-11 Input Capture Timing (1-State Delay, Buffer Mode)

8.4.5 Timing of Input Capture Flag (ICF) Setting

The input capture flag ICF_x (x = A, B, C, D) is set to 1 by the internal input capture signal. Figure 8-12 shows the timing of this operation.

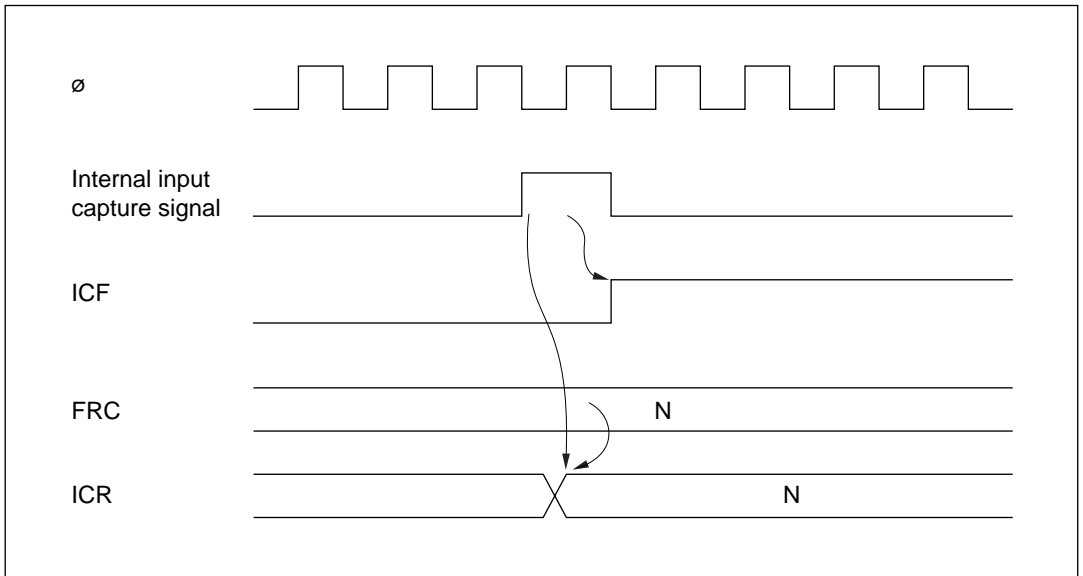

Figure 8-12 Setting of Input Capture Flag

8.4.6 Setting of Output Compare Flags A and B (OCFA and OCFB)

The output compare flags are set to 1 by an internal compare-match signal generated when the FRC value matches the OCRA or OCRB value. This compare-match signal is generated at the last state in which the two values match, just before FRC increments to a new value.

Accordingly, when the FRC and OCR values match, the compare-match signal is not generated until the next period of the clock source. Figure 8-13 shows the timing of the setting of the output compare flags.

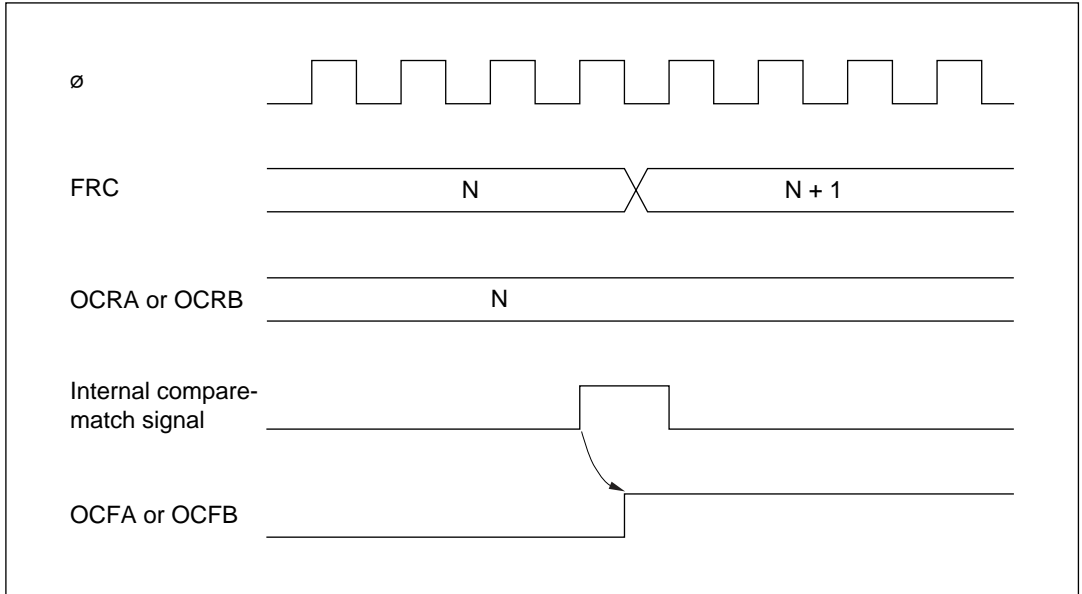

Figure 8-13 Setting of Output Compare Flags

8.4.7 Setting of FRC Overflow Flag (OVF)

The FRC overflow flag (OVF) is set to 1 when FRC overflows (changes from H'FFFF to H'0000). Figure 8-14 shows the timing of this operation.

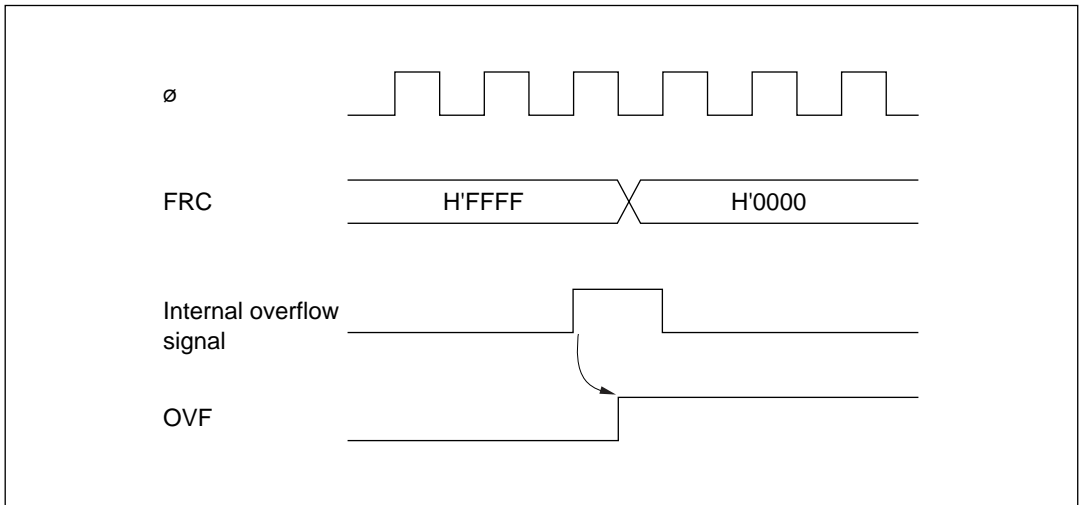

Figure 8-14 Setting of Overflow Flag (OVF)

8.5 Interrupts

The free-running timer can request seven interrupts (three types): input capture A to D (ICIA, ICIB, ICIC, ICID), output compare A and B (OCIA and OCIB), and overflow (FOVI). Each interrupt can be enabled or disabled by an enable bit in TIER. Independent signals are sent to the interrupt controller for each interrupt. Table 8-4 lists information about these interrupts.

Table 8-4 Free-Running Timer Interrupts

Interrupt	Description	Priority
ICIA	Requested by ICFA	<div style="text-align: center;"> High ↑ ↓ Low </div>
ICIB	Requested by ICFB	
ICIC	Requested by ICFC	
ICID	Requested by ICFD	
OCIA	Requested by OCFA	
OCIB	Requested by OCFB	
FOVI	Requested by OVF	

8.6 Sample Application

In the example below, the free-running timer is used to generate two square-wave outputs with a 50% duty cycle and arbitrary phase relationship. The programming is as follows:

- (1) The CCLRA bit in TCSR is set to 1.
- (2) Each time a compare-match interrupt occurs, software inverts the corresponding output level bit in TOCR (OLVLA or OLVLB).

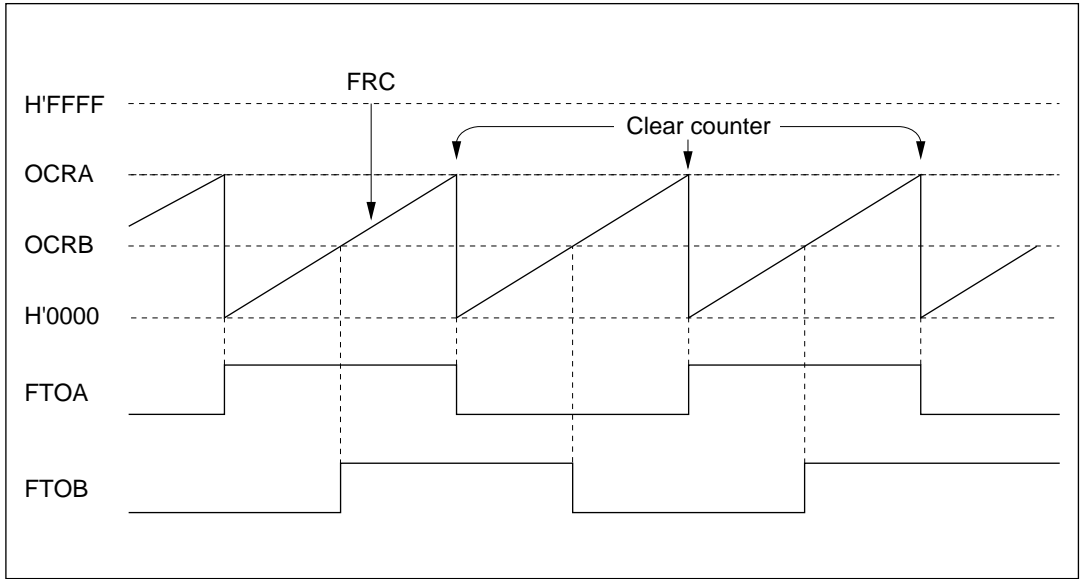

Figure 8-15 Square-Wave Output (Example)

8.7 Usage Notes

Application programmers should note that the following types of contention can occur in the free-running timer.

(1) Contention between FRC Write and Clear: If an internal counter clear signal is generated during the T_3 state of a write cycle to the lower byte of the free-running counter, the clear signal takes priority and the write is not performed.

Figure 8-16 shows this type of contention.

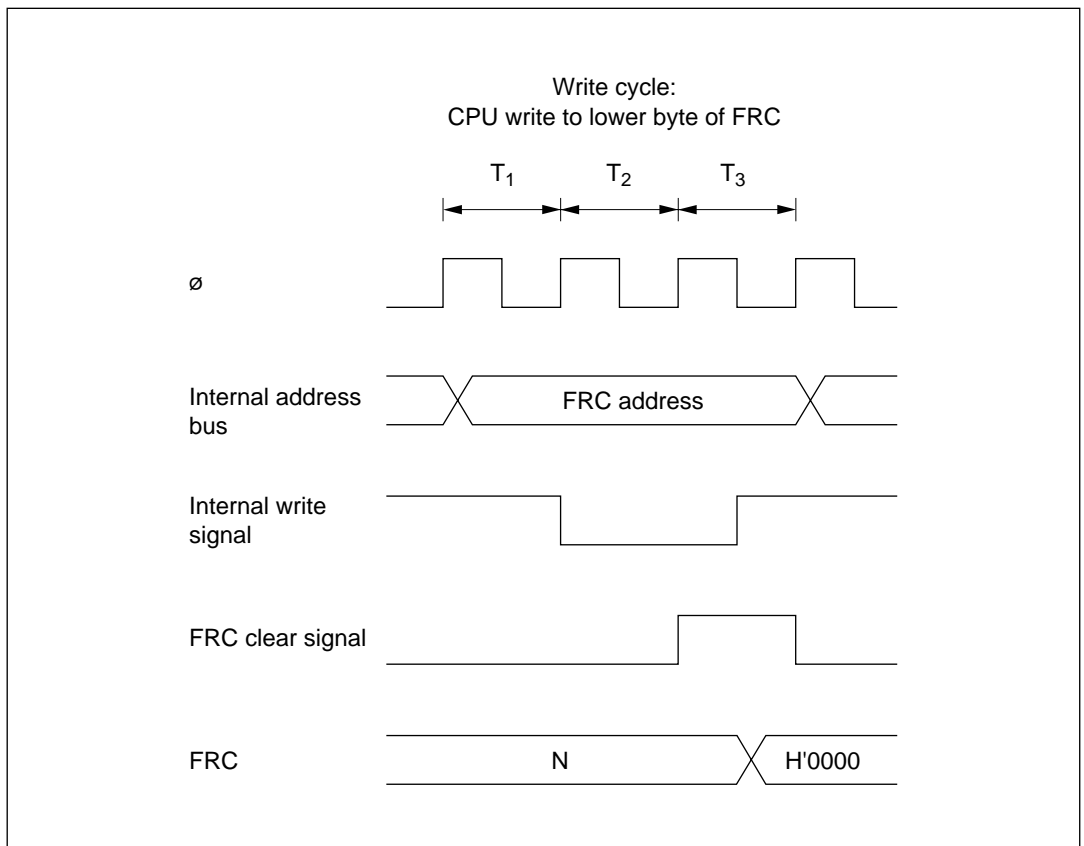

Figure 8-16 FRC Write-Clear Contention

(2) **Contention between FRC Write and Increment:** If an FRC increment pulse is generated during the T_3 state of a write cycle to the lower byte of the free-running counter, the write takes priority and FRC is not incremented.

Figure 8-17 shows this type of contention.

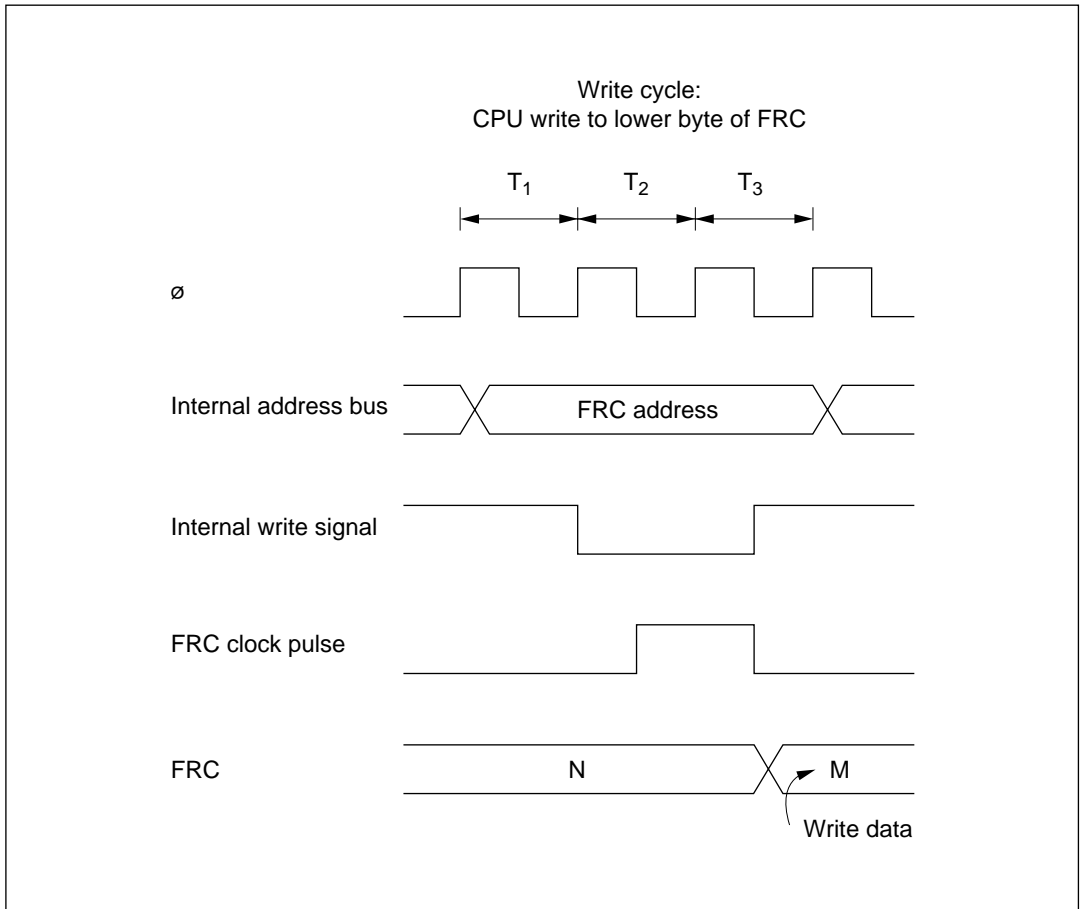

Figure 8-17 FRC Write-Increment Contention

(3) Contention between OCR Write and Compare-Match: If a compare-match occurs during the T_3 state of a write cycle to the lower byte of OCRA or OCRB, the write takes priority and the compare-match signal is inhibited.

Figure 8-18 shows this type of contention.

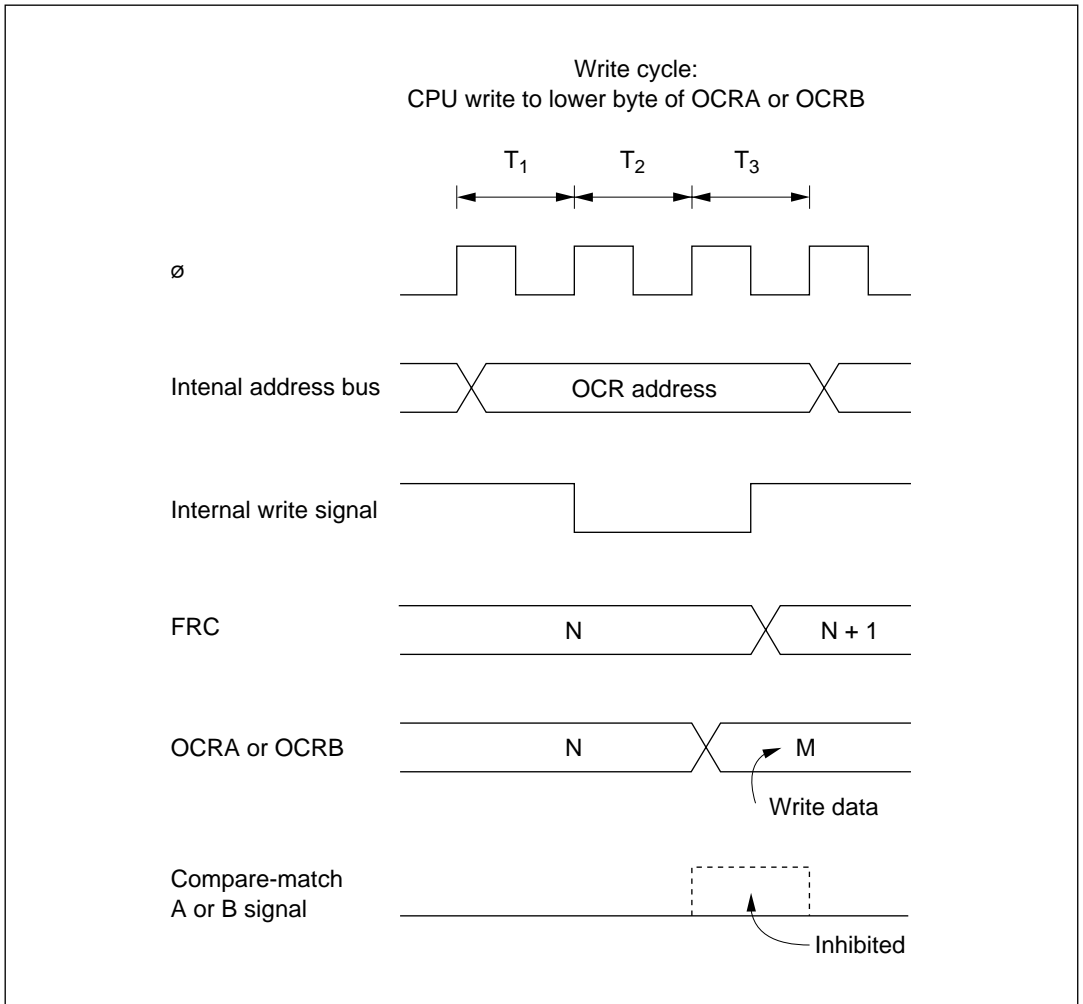

Figure 8-18 Contention between OCR Write and Compare-Match

(4) Incrementation Caused by Changing of Internal Clock Source: When an internal clock source is changed, the changeover may cause FRC to increment. This depends on the time at which the clock select bits (CKS1 and CKS0) are rewritten, as shown in table 8-5.

The pulse that increments FRC is generated at the falling edge of the internal clock source. If clock sources are changed when the old source is high and the new source is low, as in case no. 3 in table 8-5, the changeover generates a falling edge that triggers the FRC increment clock pulse.

Switching between an internal and external clock source can also cause FRC to increment.

Table 8-5 Effect of Changing Internal Clock Sources

No.	Description	Timing
1	Low → low: CKS1 and CKS0 are rewritten while both clock sources are low.	
2	Low → high: CKS1 and CKS0 are rewritten while old clock source is low and new clock source is high.	

Table 8-5 Effect of Changing Internal Clock Sources (cont)

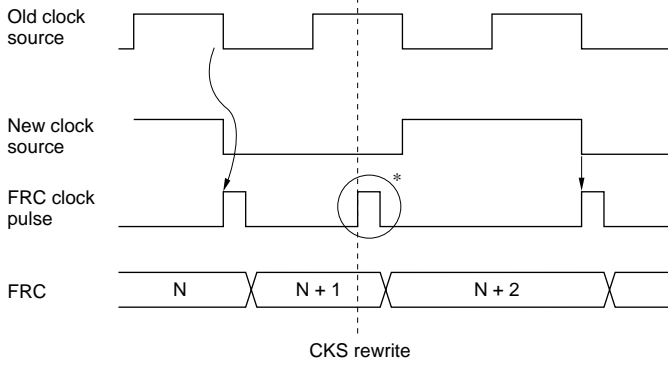
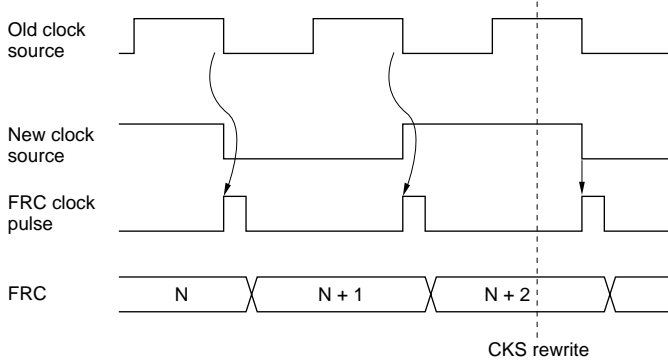
No.	Description	Timing
3	<p>High → low: CKS1 and CKS0 are rewritten while old clock source is high and new clock source is low.</p>	 <p>Old clock source</p> <p>New clock source</p> <p>FRC clock pulse</p> <p>FRC</p> <p>N N + 1 N + 2</p> <p>CKS rewrite</p>
4	<p>High → high: CKS1 and CKS0 are rewritten while both clock sources are high.</p>	 <p>Old clock source</p> <p>New clock source</p> <p>FRC clock pulse</p> <p>FRC</p> <p>N N + 1 N + 2</p> <p>CKS rewrite</p>

Note: * The switching of clock sources is regarded as a falling edge that increments FRC.

Section 9 8-Bit Timers

9.1 Overview

The H8/3297 Series includes an 8-bit timer module with two channels (numbered 0 and 1). Each channel has an 8-bit counter (TCNT) and two time constant registers (TCORA and TCORB) that are constantly compared with the TCNT value to detect compare-match events. One of the many applications of the 8-bit timer module is to generate a rectangular-wave output with an arbitrary duty cycle.

9.1.1 Features

The features of the 8-bit timer module are listed below.

- Selection of seven clock sources

The counters can be driven by one of six internal clock signals or an external clock input (enabling use as an external event counter).

- Selection of three ways to clear the counters

The counters can be cleared on compare-match A or B, or by an external reset signal.

- Timer output controlled by two time constants

The timer output signal in each channel is controlled by two independent time constants, enabling the timer to generate output waveforms with an arbitrary duty cycle, or PWM waveforms.

- Three independent interrupts

Compare-match A and B and overflow interrupts can be requested independently.

9.1.2 Block Diagram

Figure 9-1 shows a block diagram of one channel in the 8-bit timer module.

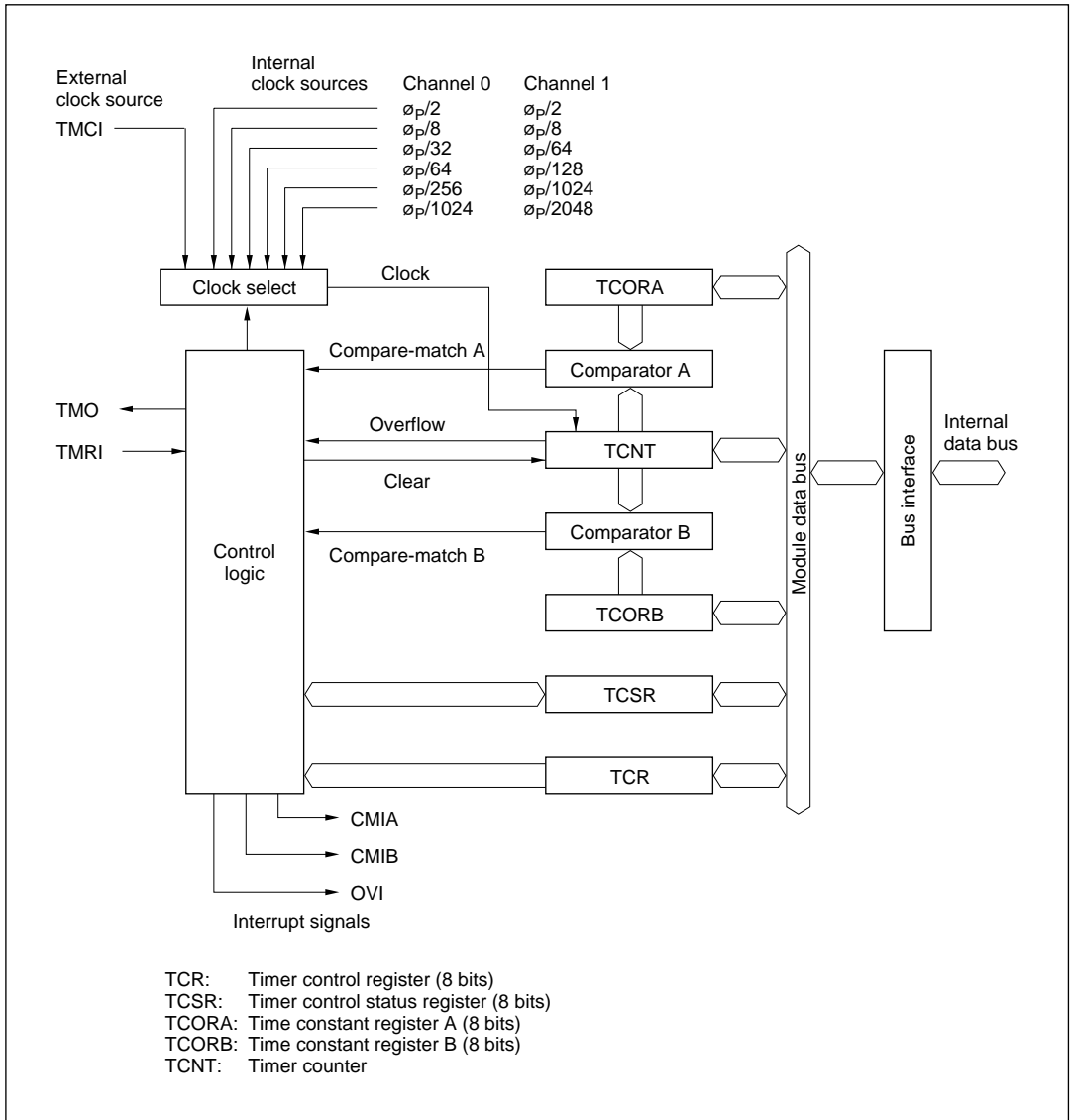

Figure 9-1 Block Diagram of 8-Bit Timer (1 Channel)

9.1.3 Input and Output Pins

Table 9-1 lists the input and output pins of the 8-bit timer.

Table 9-1 Input and Output Pins of 8-Bit Timer

Name	Abbreviation*		I/O	Function
	Channel 0	Channel 1		
Timer output	TMO ₀	TMO ₁	Output	Output controlled by compare-match
Timer clock input	TMCI ₀	TMCI ₁	Input	External clock source for the counter
Timer reset input	TMRI ₀	TMRI ₁	Input	External reset signal for the counter

Note: * In this manual, the channel subscript has been deleted, and only TMO, TMCI, and TMRI are used.

9.1.4 Register Configuration

Table 9-2 lists the registers of the 8-bit timer module. Each channel has an independent set of registers.

Table 9-2 8-Bit Timer Registers

Channel	Name	Abbreviation	R/W	Initial Value	Address
0	Timer control register	TCR	R/W	H'00	H'FFC8
	Timer control/status register	TCSR	R/(W)*	H'10	H'FFC9
	Time constant register A	TCORA	R/W	H'FF	H'FFCA
	Time constant register B	TCORB	R/W	H'FF	H'FFCB
	Timer counter	TCNT	R/W	H'00	H'FFCC
1	Timer control register	TCR	R/W	H'00	H'FFD0
	Timer control/status register	TCSR	R/(W)*	H'10	H'FFD1
	Time constant register A	TCORA	R/W	H'FF	H'FFD2
	Time constant register B	TCORB	R/W	H'FF	H'FFD3
	Timer counter	TCNT	R/W	H'00	H'FFD4
0, 1	Serial/timer control register	STCR	R/W	H'F8	H'FFC3

Note: * Software can write a 0 to clear bits 7 to 5, but cannot write a 1 in these bits.

9.2 Register Descriptions

9.2.1 Timer Counter (TCNT)

Bit	7	6	5	4	3	2	1	0
Initial value	0	0	0	0	0	0	0	0
Read/Write	R/W	R/W	R/W	R/W	R/W	R/W	R/W	R/W

Each timer counter (TCNT) is an 8-bit up-counter that increments on a pulse generated from an internal or external clock source selected by clock select bits 2 to 0 (CKS2 to CKS0) of the timer control register (TCR). The CPU can always read or write the timer counter.

The timer counter can be cleared by an external reset input or by an internal compare-match signal generated at a compare-match event. Clock clear bits 1 and 0 (CCLR1 and CCLR0) of the timer control register select the method of clearing.

When a timer counter overflows from H'FF to H'00, the overflow flag (OVF) in the timer control/status register (TCSR) is set to 1.

The timer counters are initialized to H'00 at a reset and in the standby modes.

9.2.2 Time Constant Registers A and B (TCORA and TCORB)

Bit	7	6	5	4	3	2	1	0
Initial value	1	1	1	1	1	1	1	1
Read/Write	R/W	R/W	R/W	R/W	R/W	R/W	R/W	R/W

TCORA and TCORB are 8-bit readable/writable registers. The timer count is continually compared with the constants written in these registers (except during the T_3 state of a write cycle to TCORA or TCORB). When a match is detected, the corresponding compare-match flag (CMFA or CMFB) is set in the timer control/status register (TCSR).

The timer output signal is controlled by these compare-match signals as specified by output select bits 3 to 0 (OS3 to OS0) in the timer control/status register (TCSR).

TCORA and TCORB are initialized to H'FF at a reset and in the standby modes.

9.2.3 Timer Control Register (TCR)

Bit	7	6	5	4	3	2	1	0
	CMIEB	CMIEA	OVIE	CCLR1	CCLR0	CKS2	CKS1	CKS0
Initial value	0	0	0	0	0	0	0	0
Read/Write	R/W	R/W	R/W	R/W	R/W	R/W	R/W	R/W

TCR is an 8-bit readable/writable register that selects the clock source and the time at which the timer counter is cleared, and enables interrupts.

TCR is initialized to H'00 at a reset and in the standby modes.

For timing diagrams, see section 9.3, Operation.

Bit 7—Compare-match Interrupt Enable B (CMIEB): This bit selects whether to request compare-match interrupt B (CMIB) when compare-match flag B (CMFB) in the timer control/status register (TCSR) is set to 1.

Bit 7

CMIEB	Description
0	Compare-match interrupt request B (CMIB) is disabled. (Initial value)
1	Compare-match interrupt request B (CMIB) is enabled.

Bit 6—Compare-match Interrupt Enable A (CMIEA): This bit selects whether to request compare-match interrupt A (CMIA) when compare-match flag A (CMFA) in TCSR is set to 1.

Bit 6

CMIEA	Description
0	Compare-match interrupt request A (CMIA) is disabled. (Initial value)
1	Compare-match interrupt request A (CMIA) is enabled.

Bit 5—Timer Overflow Interrupt Enable (OVIE): This bit selects whether to request a timer overflow interrupt (OVI) when the overflow flag (OVF) in TCSR is set to 1.

Bit 5

OVIE	Description	
0	The timer overflow interrupt request (OVI) is disabled.	(Initial value)
1	The timer overflow interrupt request (OVI) is enabled.	

Bits 4 and 3—Counter Clear 1 and 0 (CCLR1 and CCLR0): These bits select how the timer counter is cleared: by compare-match A or B or by an external reset input (TMRI).

Bit 4 CCLR1	Bit 3 CCLR0	Description	
0	0	Not cleared.	(Initial value)
0	1	Cleared on compare-match A.	
1	0	Cleared on compare-match B.	
1	1	Cleared on rising edge of external reset input signal.	

Bits 2, 1, and 0—Clock Select (CKS2, CKS1, and CKS0): These bits and bits ICKS1 and ICKS0 in the serial/timer control register (STCR) select the internal or external clock source for the timer counter. Six internal clock sources, derived by prescaling the system clock, are available for each timer channel. For internal clock sources the counter is incremented on the falling edge of the internal clock. For an external clock source, these bits can select whether to increment the counter on the rising or falling edge of the clock input (TMCI), or on both edges.

Channel	TCR			STCR		Description
	Bit 2 CKS2	Bit 1 CKS1	Bit 0 CKS0	Bit 1 ICKS1	Bit 0 ICKS0	
0	0	0	0	—	—	No clock source (timer stopped) (Initial value)
	0	0	1	—	0	$\phi_p/8$ internal clock, counted on falling edge
	0	0	1	—	1	$\phi_p/2$ internal clock, counted on falling edge
	0	1	0	—	0	$\phi_p/64$ internal clock, counted on falling edge
	0	1	0	—	1	$\phi_p/32$ internal clock, counted on falling edge
	0	1	1	—	0	$\phi_p/1024$ internal clock, counted on falling edge
	0	1	1	—	1	$\phi_p/256$ internal clock, counted on falling edge
	1	0	0	—	—	No clock source (timer stopped)
	1	0	1	—	—	External clock source, counted on rising edge
	1	1	0	—	—	External clock source, counted on falling edge
	1	1	1	—	—	External clock source, counted on both rising and falling edges
1	0	0	0	—	—	No clock source (timer stopped) (Initial value)
	0	0	1	0	—	$\phi_p/8$ internal clock, counted on falling edge
	0	0	1	1	—	$\phi_p/2$ internal clock, counted on falling edge
	0	1	0	0	—	$\phi_p/64$ internal clock, counted on falling edge
	0	1	0	1	—	$\phi_p/128$ internal clock, counted on falling edge
	0	1	1	0	—	$\phi_p/1024$ internal clock, counted on falling edge
	0	1	1	1	—	$\phi_p/2048$ internal clock, counted on falling edge
	1	0	0	—	—	No clock source (timer stopped)
	1	0	1	—	—	External clock source, counted on rising edge
	1	1	0	—	—	External clock source, counted on falling edge
	1	1	1	—	—	External clock source, counted on both rising and falling edges

9.2.4 Timer Control/Status Register (TCSR)

Bit	7	6	5	4	3	2	1	0
	CMFB	CMFA	OVF	—	OS3	OS2	OS1	OS0
Initial value	0	0	0	1	0	0	0	0
Read/Write	R/(W)*	R/(W)*	R/(W)*	—	R/W	R/W	R/W	R/W

Note: * Software can write a 0 in bits 7 to 5 to clear the flags, but cannot write a 1 in these bits.

TCSR is an 8-bit readable and partially writable register that indicates compare-match and overflow status and selects the effect of compare-match events on the timer output signal.

TCSR is initialized to H'10 at a reset and in the standby modes.

Bit 7—Compare-Match Flag B (CMFB): This status flag is set to 1 when the timer count matches the time constant set in TCORB. CMFB must be cleared by software. It is set by hardware, however, and cannot be set by software.

Bit 7

CMFB	Description
0	To clear CMFB, the CPU must read CMFB after it has been set to 1 (Initial value) then write a 0 in this bit.
1	This bit is set to 1 when TCNT = TCORB.

Bit 6—Compare-Match Flag A (CMFA): This status flag is set to 1 when the timer count matches the time constant set in TCORA. CMFA must be cleared by software. It is set by hardware, however, and cannot be set by software.

Bit 6

CMFA	Description
0	To clear CMFA, the CPU must read CMFA after it has been set to 1, (Initial value) then write a 0 in this bit.
1	This bit is set to 1 when TCNT = TCORA.

Bit 5—Timer Overflow Flag (OVF): This status flag is set to 1 when the timer count overflows (changes from H'FF to H'00). OVF must be cleared by software. It is set by hardware, however, and cannot be set by software.

Bit 5

OVF	Description	
0	To clear OVF, the CPU must read OVF after it has been set to 1, then write a 0 in this bit.	(Initial value)
1	This bit is set to 1 when TCNT changes from H'FF to H'00.	

Bit 4—Reserved: This bit is always read as 1. It cannot be written.

Bits 3 to 0—Output Select 3 to 0 (OS3 to OS0): These bits specify the effect of TCOR–TCNT compare-match events on the timer output signal (TMO). Bits OS3 and OS2 control the effect of compare-match B on the output level. Bits OS1 and OS0 control the effect of compare-match A on the output level.

If compare-match A and B occur simultaneously, any conflict is resolved according to the following priority order: toggle > 1 output > 0 output.

When all four output select bits are cleared to 0 the timer output signal is disabled.

After a reset, the timer output is 0 until the first compare-match event.

Bit 3 OS3	Bit 2 OS2	Description	
0	0	No change when compare-match B occurs.	(Initial value)
0	1	Output changes to 0 when compare-match B occurs.	
1	0	Output changes to 1 when compare-match B occurs.	
1	1	Output inverts (toggles) when compare-match B occurs.	

Bit 1 OS1	Bit 0 OS0	Description	
0	0	No change when compare-match A occurs.	(Initial value)
0	1	Output changes to 0 when compare-match A occurs.	
1	0	Output changes to 1 when compare-match A occurs.	
1	1	Output inverts (toggles) when compare-match A occurs.	

9.2.5 Serial/Timer Control Register (STCR)

Bit	7	6	5	4	3	2	1	0
	—	—	—	—	—	MPE	ICKS1	ICKS0
Initial value	1	1	1	1	1	0	0	0
Read/Write	—	—	—	—	—	R/W	R/W	R/W

STCR is an 8-bit readable/writable register that controls the operating mode of the serial communication interface, and selects internal clock sources for the timer counters.

STCR is initialized to H'F8 at a reset.

Bits 7 to 3—Reserved: These bits cannot be modified and are always read as 1.

Bit 2—Multiprocessor Enable (MPE): Controls the operating mode of serial communication interfaces 0 and 1. For details, see section 11, Serial Communication Interface.

Bits 1 and 0—Internal Clock Source Select 1 and 0 (ICKS1 and ICKS0): These bits and bits CKS2 to CKS0 in the TCR select clock sources for the timer counters. For details, see section 9.2.3, Timer Control Register.

9.3 Operation

9.3.1 TCNT Incrementation Timing

The timer counter increments on a pulse generated once for each period of the selected (internal or external) clock source.

Internal Clock: Internal clock sources are created from the system clock by a prescaler. The counter increments on an internal TCNT clock pulse generated from the falling edge of the prescaler output, as shown in figure 9-2. Bits CKS2 to CKS0 of TCR and bits ICKS1 and ICKS0 of STCR can select one of the six internal clocks.

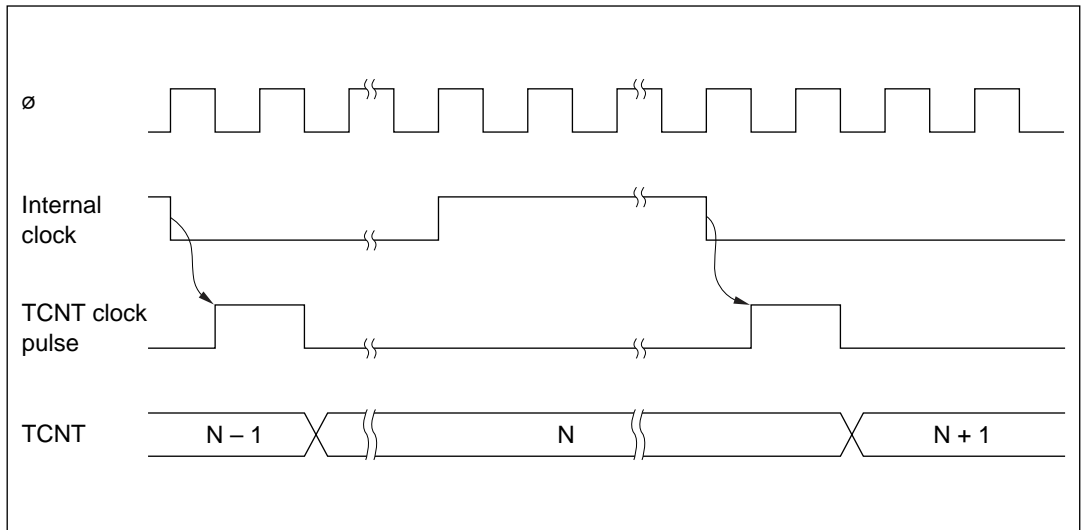

Figure 9-2 Count Timing for Internal Clock Input

External Clock: If external clock input (TMCI) is selected, the timer counter can increment on the rising edge, the falling edge, or both edges of the external clock signal. Figure 9-3 shows incrementation on both edges of the external clock signal.

The external clock pulse width must be at least 1.5 system clock (ϕ) periods for incrementation on a single edge, and at least 2.5 system clock periods for incrementation on both edges. The counter will not increment correctly if the pulse width is shorter than these values.

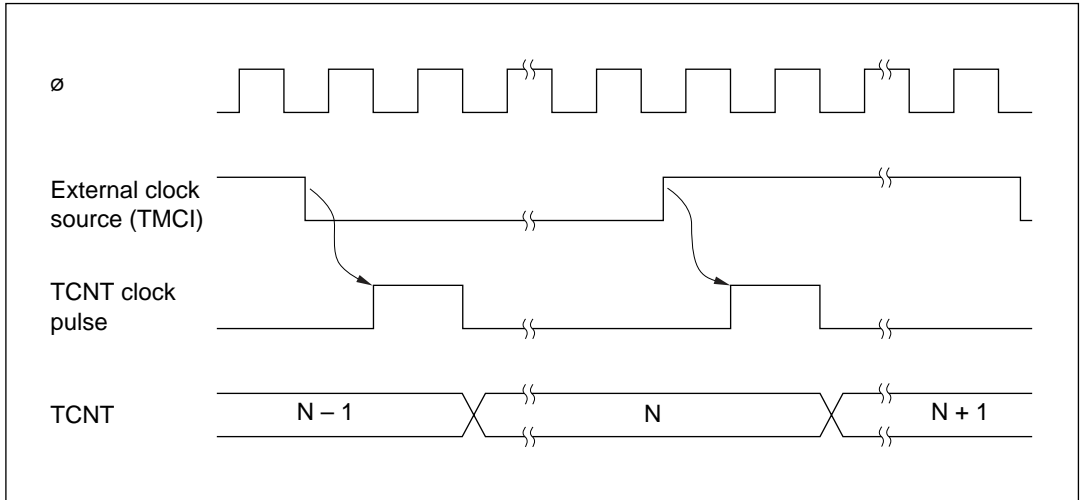

Figure 9-3 Count Timing for External Clock Input

9.3.2 Compare Match Timing

(1) **Setting of Compare-Match Flags A and B (CMFA and CMFB):** The compare-match flags are set to 1 by an internal compare-match signal generated when the timer count matches the time constant in TCORA or TCORB. The compare-match signal is generated at the last state in which the match is true, just before the timer counter increments to a new value.

Accordingly, when the timer count matches one of the time constants, the compare-match signal is not generated until the next period of the clock source. Figure 9-4 shows the timing of the setting of the compare-match flags.

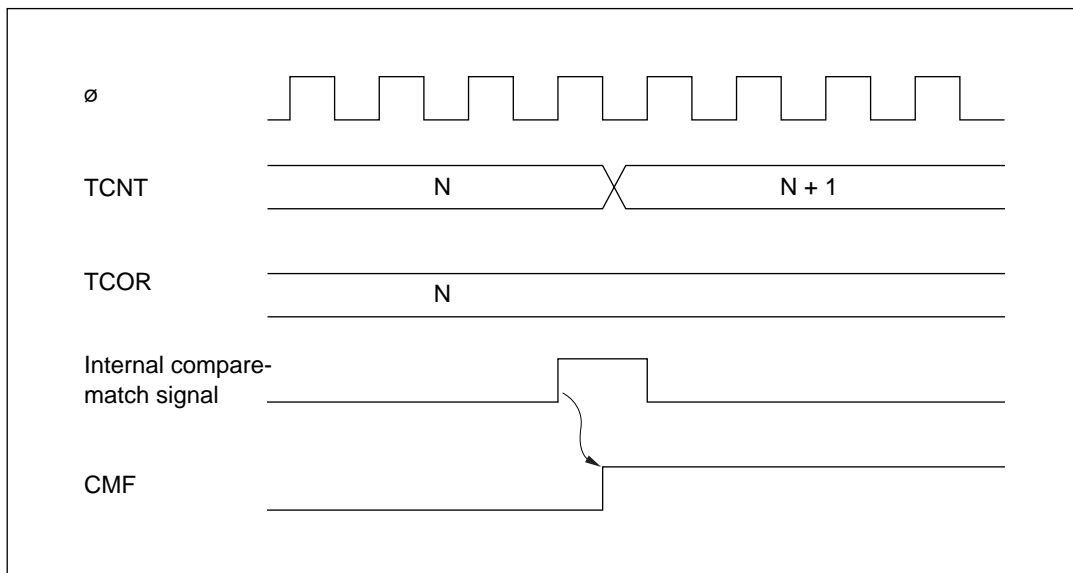

Figure 9-4 Setting of Compare-Match Flags

(2) **Output Timing:** When a compare-match event occurs, the timer output changes as specified by the output select bits (OS3 to OS0) in the TCSR. Depending on these bits, the output can remain the same, change to 0, change to 1, or toggle.

Figure 9-5 shows the timing when the output is set to toggle on compare-match A.

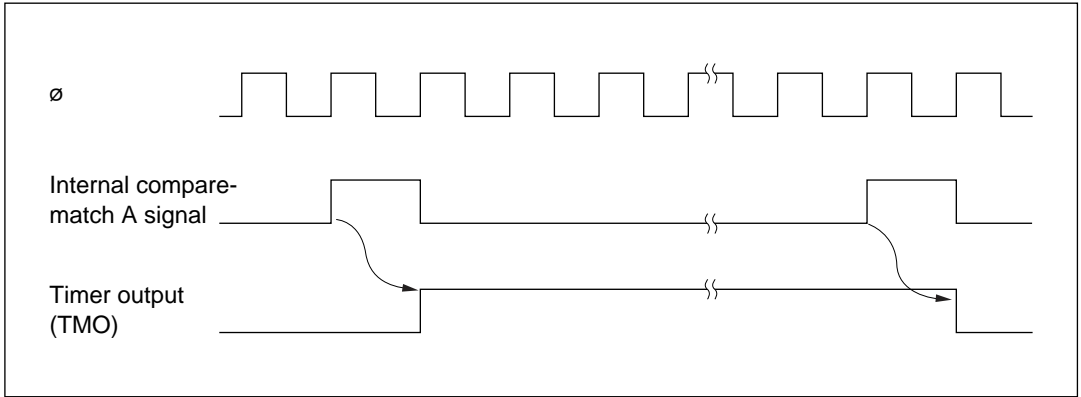

Figure 9-5 Timing of Timer Output

(3) **Timing of Compare-Match Clear:** Depending on the CCLR1 and CCLR0 bits in TCR, the timer counter can be cleared when compare-match A or B occurs. Figure 9-6 shows the timing of this operation.

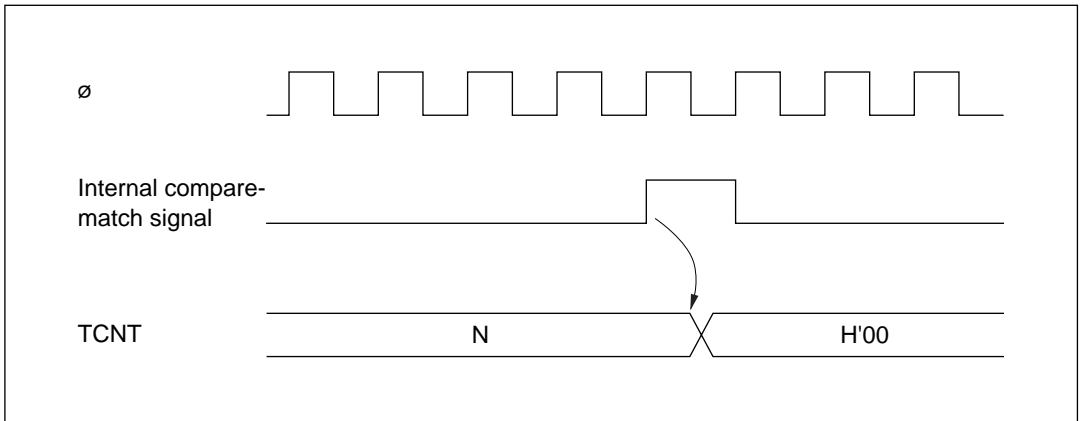

Figure 9-6 Timing of Compare-Match Clear

9.3.3 External Reset of TCNT

When the CCLR1 and CCLR0 bits in TCR are both set to 1, the timer counter is cleared on the rising edge of an external reset input. Figure 9-7 shows the timing of this operation. The timer reset pulse width must be at least 1.5 system clock (ϕ) periods.

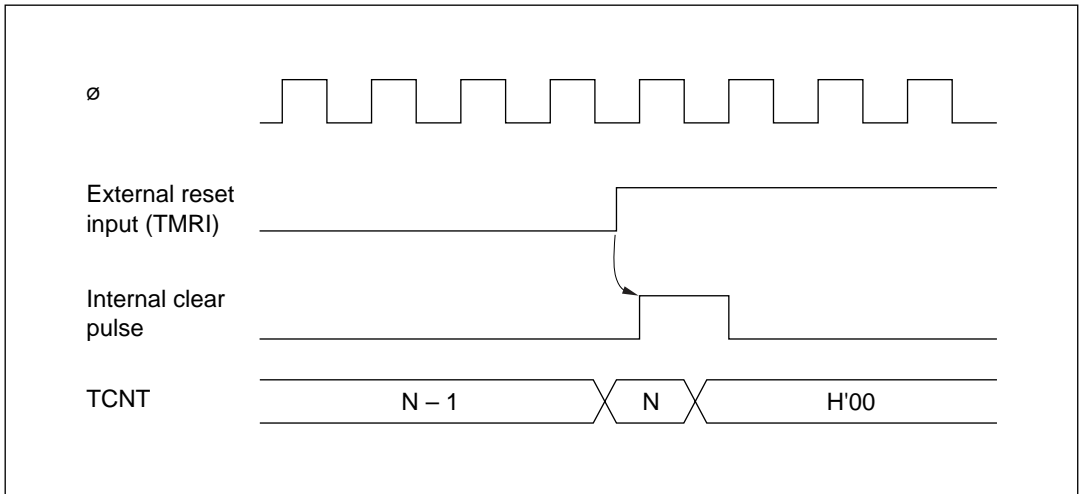

Figure 9-7 Timing of External Reset

9.3.4 Setting of TCSR Overflow Flag (OVF)

The overflow flag (OVF) is set to 1 when the timer count overflows (changes from H'FF to H'00). Figure 9-8 shows the timing of this operation.

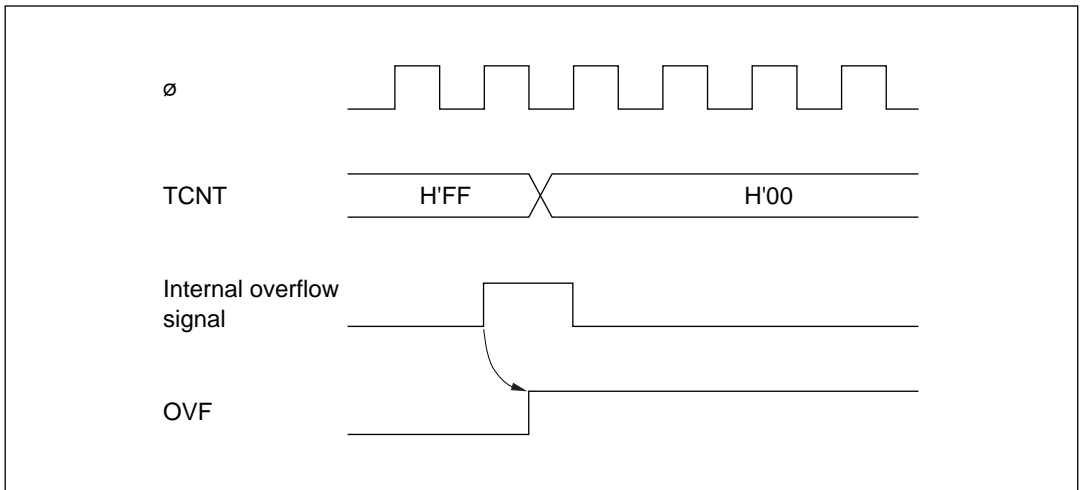

Figure 9-8 Setting of Overflow Flag (OVF)

9.4 Interrupts

Each channel in the 8-bit timer can generate three types of interrupts: compare-match A and B (CMIA and CMIB), and overflow (OVI). Each interrupt can be enabled or disabled by an enable bit in TCR. Independent signals are sent to the interrupt controller for each interrupt. Table 9-3 lists information about these interrupts.

Table 9-3 8-Bit Timer Interrupts

Interrupt	Description	Priority
CMIA	Requested by CMFA	High
CMIB	Requested by CMFB	↕
OVI	Requested by OVF	Low

9.5 Sample Application

In the example below, the 8-bit timer is used to generate a pulse output with a selected duty cycle. The control bits are set as follows:

- (1) In TCR, CCLR1 is cleared to 0 and CCLR0 is set to 1 so that the timer counter is cleared when its value matches the constant in TCORA.
- (2) In TCSR, bits OS3 to OS0 are set to 0110, causing the output to change to 1 on compare-match A and to 0 on compare-match B.

With these settings, the 8-bit timer provides output of pulses at a rate determined by TCORA with a pulse width determined by TCORB. No software intervention is required.

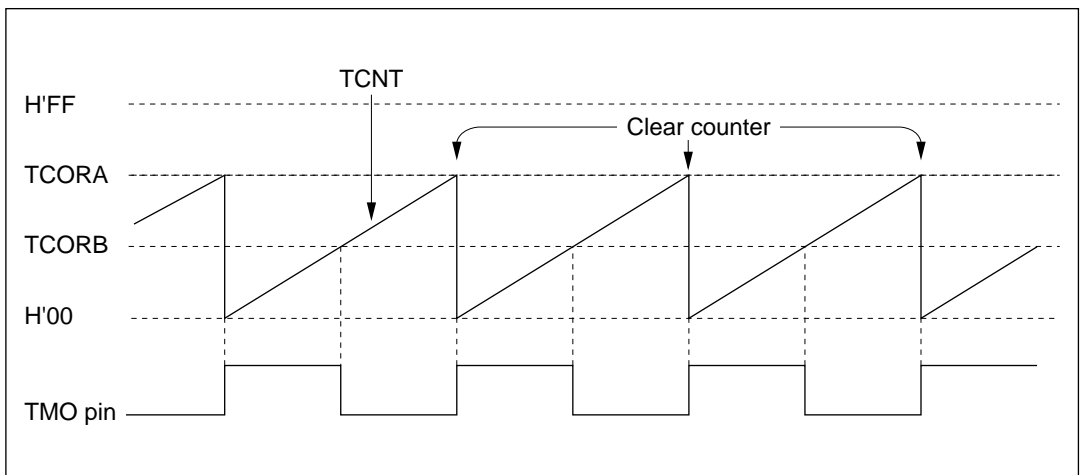

Figure 9-9 Example of Pulse Output

9.6 Usage Notes

Application programmers should note that the following types of contention can occur in the 8-bit timer.

9.6.1 Contention between TCNT Write and Clear

If an internal counter clear signal is generated during the T_3 state of a write cycle to the timer counter, the clear signal takes priority and the write is not performed.

Figure 9-10 shows this type of contention.

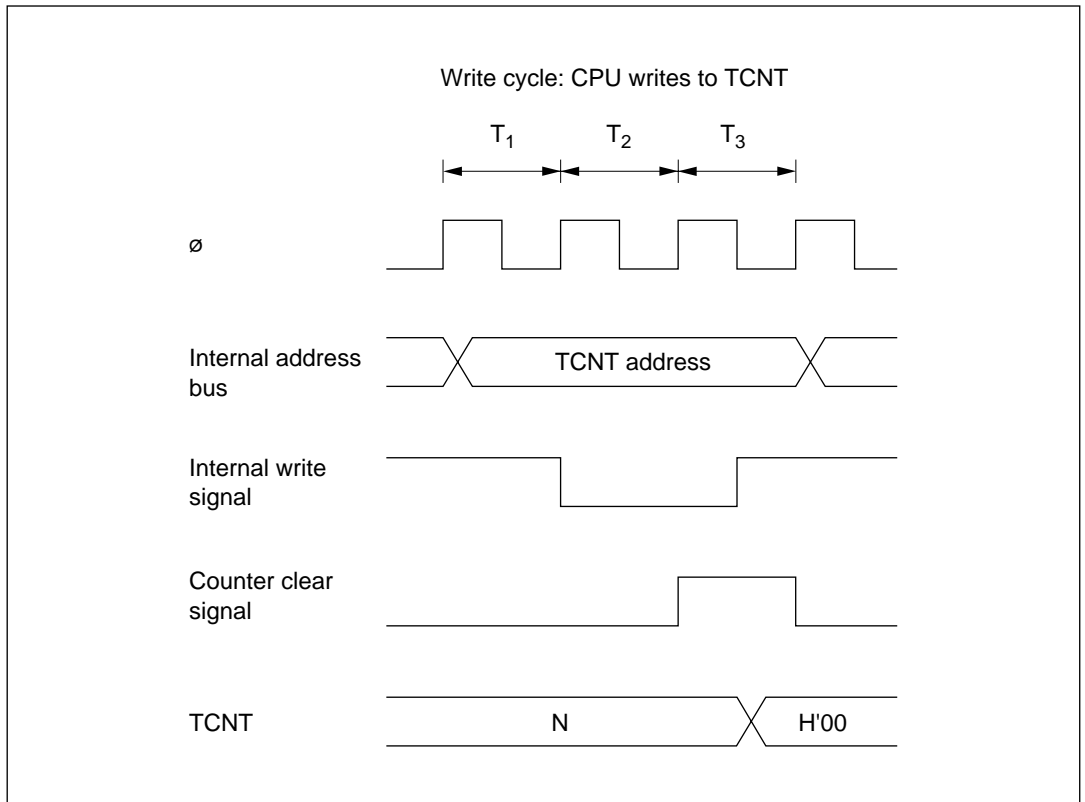

Figure 9-10 TCNT Write-Clear Contention

9.6.2 Contention between TCNT Write and Increment

If a timer counter increment pulse is generated during the T_3 state of a write cycle to the timer counter, the write takes priority and the timer counter is not incremented.

Figure 9-11 shows this type of contention.

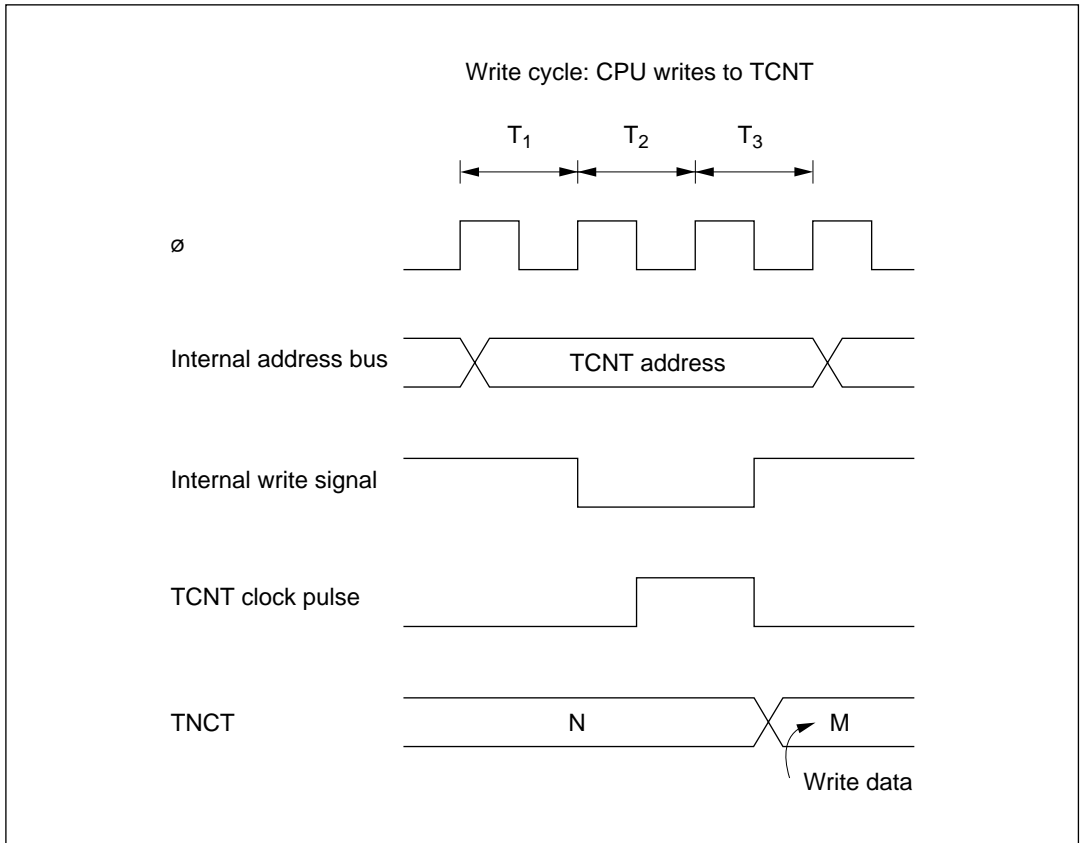

Figure 9-11 TCNT Write-Increment Contention

9.6.3 Contention between TCOR Write and Compare-Match

If a compare-match occurs during the T_3 state of a write cycle to TCOR, the write takes precedence and the compare-match signal is inhibited.

Figure 9-12 shows this type of contention.

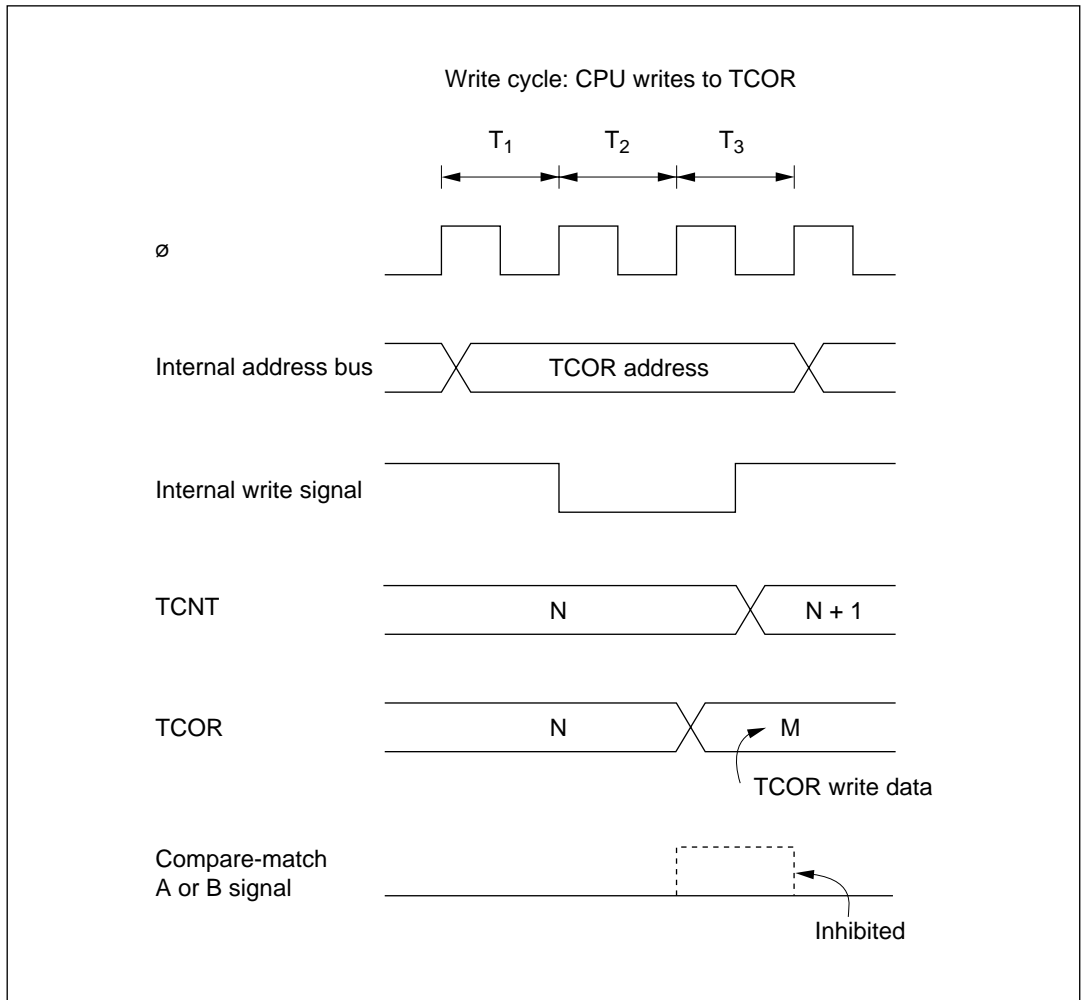

Figure 9-12 Contention between TCOR Write and Compare-Match

9.6.4 Contention between Compare-Match A and Compare-Match B

If identical time constants are written in TCORA and TCORB, causing compare-match A and B to occur simultaneously, any conflict between the output selections for compare-match A and B is resolved by following the priority order in table 9-4.

Table 9-4 Priority of Timer Output

Output Selection	Priority
Toggle	High
1 output	↑
0 output	↑
No change	Low

9.6.5 Incrementation Caused by Changing of Internal Clock Source

When an internal clock source is changed, the changeover may cause the timer counter to increment. This depends on the time at which the clock select bits (CKS1, CKS0) are rewritten, as shown in table 9-5.

The pulse that increments the timer counter is generated at the falling edge of the internal clock source signal. If clock sources are changed when the old source is high and the new source is low, as in case no. 3 in table 9-5, the changeover generates a falling edge that triggers the TCNT clock pulse and increments the timer counter.

Switching between an internal and external clock source can also cause the timer counter to increment.

Table 9-5 Effect of Changing Internal Clock Sources

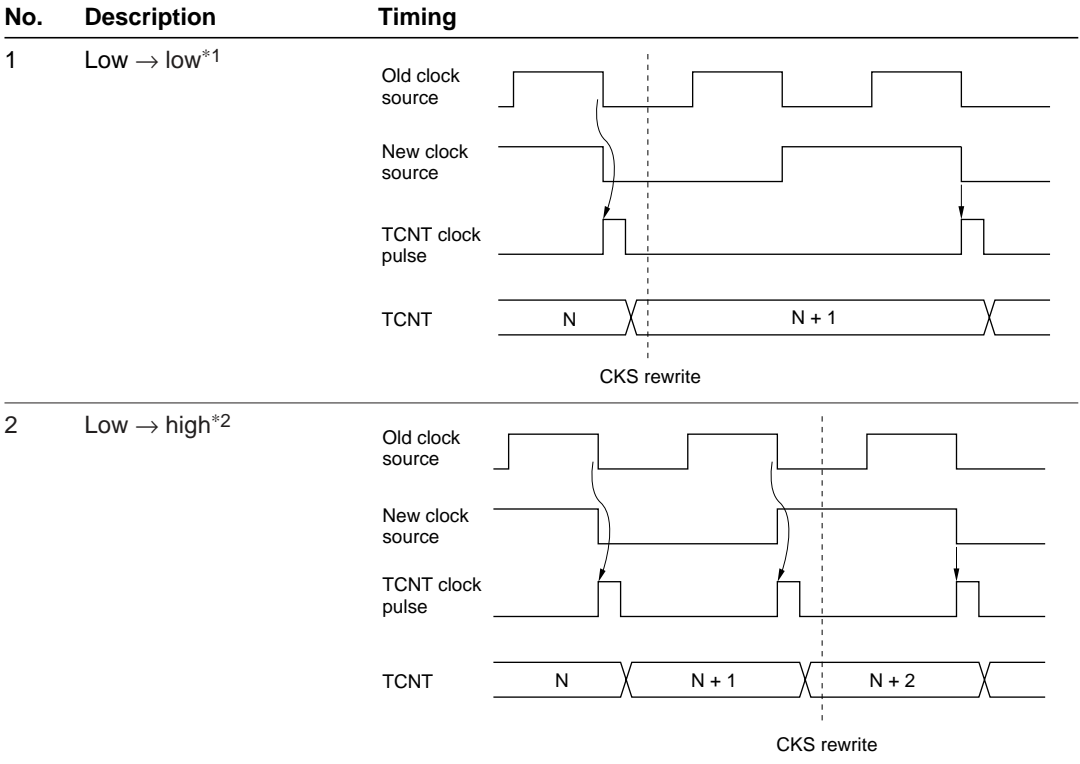

Notes: 1. Including a transition from low to the stopped state (CKS1 = 0, CKS0 = 0), or a transition from the stopped state to low.
 2. Including a transition from the stopped state to high.

Table 9-5 Effect of Changing Internal Clock Sources (cont)

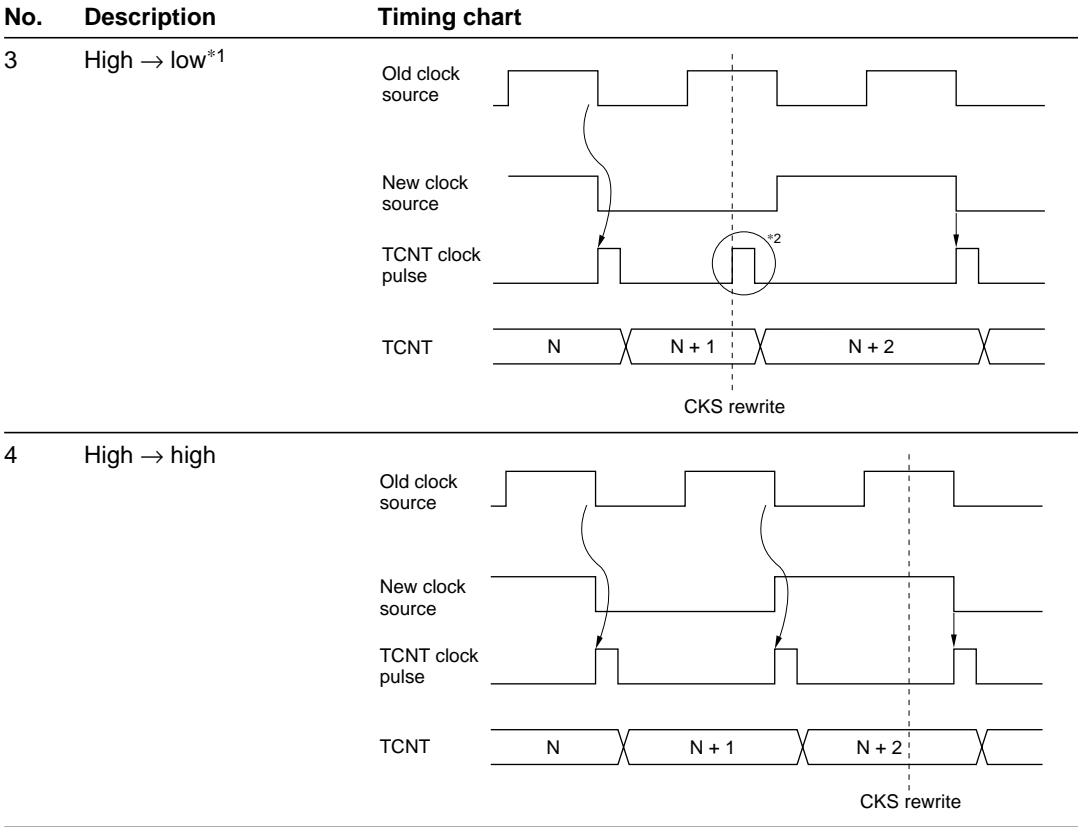

- Notes: 1. Including a transition from high to the stopped state.
 2. The switching of clock sources is regarded as a falling edge that increments TCNT.

Section 10 Watchdog Timer

10.1 Overview

The H8/3297 Series has an on-chip watchdog timer (WDT) that can monitor system operation by resetting the CPU or generating a nonmaskable interrupt if a system crash allows the timer count to overflow.

When this watchdog function is not needed, the watchdog timer module can be used as an interval timer. In interval timer mode, it requests an OVF interrupt at each counter overflow.

10.1.1 Features

- Selection of eight clock sources
- Selection of two modes:
 - Watchdog timer mode
 - Interval timer mode
- Counter overflow generates an interrupt request or reset:
 - Reset or NMI request in watchdog timer mode
 - OVF interrupt request in interval timer mode

10.1.2 Block Diagram

Figure 10-1 is a block diagram of the watchdog timer.

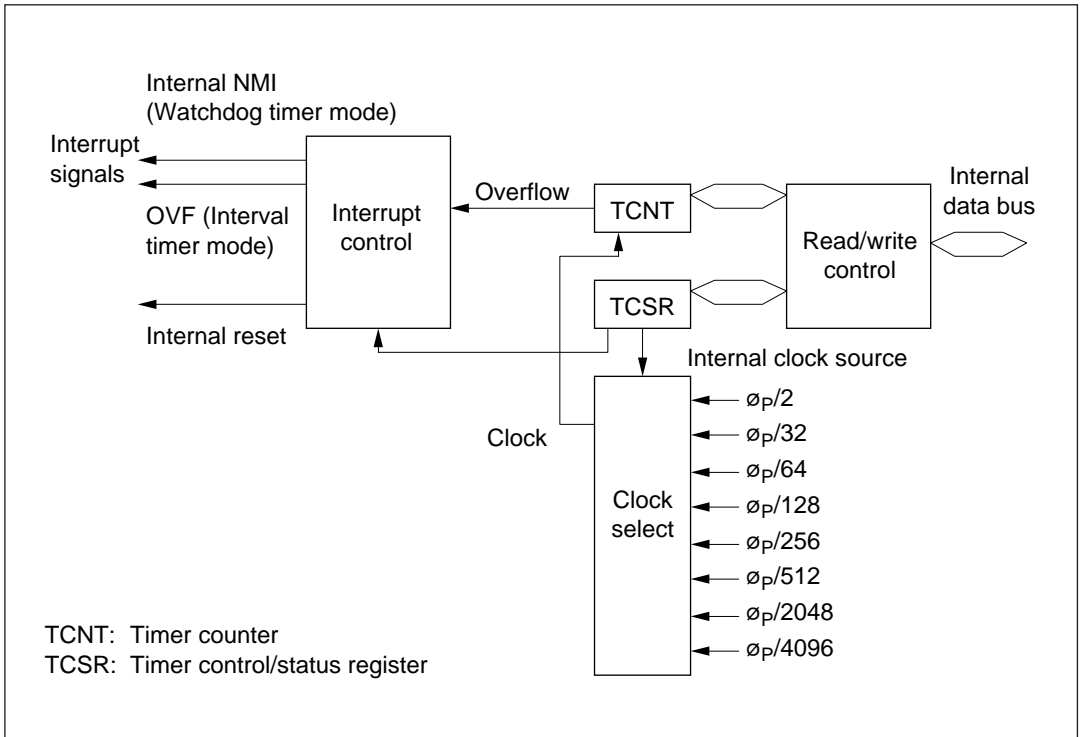

Figure 10-1 Block Diagram of Watchdog Timer

10.1.3 Register Configuration

Table 10-1 lists information on the watchdog timer registers.

Table 10-1 Register Configuration

Name	Abbreviation	R/W	Initial Value	Addresses	
				Write	Read
Timer control/status register	TCSR	R/(W)*	H'18	H'FFA8	H'FFA8
Timer counter	TCNT	R/W	H'00	H'FFA8	H'FFA9

Note: * Software can write a 0 to clear the status flag bits, but cannot write 1.

10.2 Register Descriptions

10.2.1 Timer Counter (TCNT)

Bit	7	6	5	4	3	2	1	0
Initial value	0	0	0	0	0	0	0	0
Read/Write	R/W	R/W	R/W	R/W	R/W	R/W	R/W	R/W

TCNT is an 8-bit readable/writable up-counter. When the timer enable bit (TME) in the timer control/status register (TCSR) is set to 1, the timer counter starts counting pulses of an internal clock source selected by clock select bits 2 to 0 (CKS2 to CKS0) in TCSR. When the count overflows (changes from H'FF to H'00), an overflow flag (OVF) in TCSR is set to 1.

TCNT is initialized to H'00 at a reset and when the TME bit is cleared to 0.

Note: TCNT is more difficult to write to than other registers. See Section 10.2.3, Register Access, for details.

10.2.2 Timer Control/Status Register (TCSR)

Bit	7	6	5	4	3	2	1	0
	OVF	WT/ \overline{IT}	TME	—	RST/ \overline{NMI}	CKS2	CKS1	CKS0
Initial value	0	0	0	1	0	0	0	0
Read/Write	R/(W*)	R/W	R/W	—	R/W	R/W	R/W	R/W

Note: * Software can write a 0 in bit 7 to clear the flag, but cannot write a 1 in this bit. TCSR is more difficult to write to than other registers. See Section 12.2.3, Register Access, for details.

TCSR is an 8-bit readable/writable register that selects the timer mode and clock source and performs other functions. (TCSR is write-protected by a password. See section 10.2.3, Register Access, for details.)

Bits 7 to 5 and bit 3 are initialized to 0 at a reset and in the standby modes. Bits 2 to 0 are initialized to 0 at a reset, but retain their values in the standby modes.

Bit 7—Overflow Flag (OVF): Indicates that the watchdog timer count has overflowed.

Bit 7 OVF	Description
0	To clear OVF, the CPU must read OVF when it is 1, then write 0 in this bit (Initial value)
1	<ul style="list-style-type: none">• Set to 1 when TENT changes from H'FF to H'00• In interval timer mode or when the NMI interrupt is selected in watchdog timer mode

Bit 6—Timer Mode Select (WT/ $\overline{\text{IT}}$): Selects whether to operate in watchdog timer mode or interval timer mode. When TCNT overflows, an OVF interrupt request is sent to the CPU in interval timer mode. For watchdog timer mode, a reset or NMI interrupt is requested.

Bit 6 WT/ $\overline{\text{IT}}$	Description
0	Interval timer mode (OVF request in case of overflow) (Initial value)
1	Watchdog timer mode (reset or NMI request in case of overflow)

Bit 5—Timer Enable (TME): Enables or disables the timer.

Bit 5 TME	Description
0	TCNT is initialized to H'00 and stopped (Initial value)
1	TCNT runs and requests a reset or an interrupt when it overflows

Bit 4—Reserved: This bit cannot be modified and is always read as 1.

Bit 3: Reset or NMI Select (RST/ $\overline{\text{NMI}}$): Selects either an internal reset or the NMI function at watchdog timer overflow.

Bit 3 RST/ $\overline{\text{NMI}}$	Description
0	NMI function enabled (Initial value)
1	Reset function enabled

Bits 2—0: Clock Select (CKS2–CKS0): These bits select one of eight clock sources obtained by dividing the system clock (ϕ).

The overflow interval is the time from when the watchdog timer counter begins counting from H'00 until an overflow occurs. In interval timer mode, OVF interrupts are requested at this interval.

Bit 2 CKS2	Bit 1 CKS1	Bit 0 CKS0	Clock Source	Overflow Interval ($\phi_p = 10\text{ MHz}$)
0	0	0	$\phi_p/2$	51.2 μs (Initial value)
0	0	1	$\phi_p/32$	819.2 μs
0	1	0	$\phi_p/64$	1.6 ms
0	1	1	$\phi_p/128$	3.3 ms
1	0	0	$\phi_p/256$	6.6 ms
1	0	1	$\phi_p/512$	13.1 ms
1	1	0	$\phi_p/2048$	52.4 ms
1	1	1	$\phi_p/4096$	104.9 ms

10.2.3 Register Access

The watchdog timer’s TCNT and TCSR registers are more difficult to write than other registers. The procedures for writing and reading these registers are given below.

Writing to TCNT and TCSR: Word access is required. Byte data transfer instructions cannot be used for write access.

The TCNT and TCSR registers have the same write address. The write data must be contained in the lower byte of a word written at this address. The upper byte must contain H'5A (password for TCNT) or H'A5 (password for TCSR). See figure 10-2. The result of the access depicted in figure 10-2 is to transfer the write data from the lower byte to TCNT or TCSR.

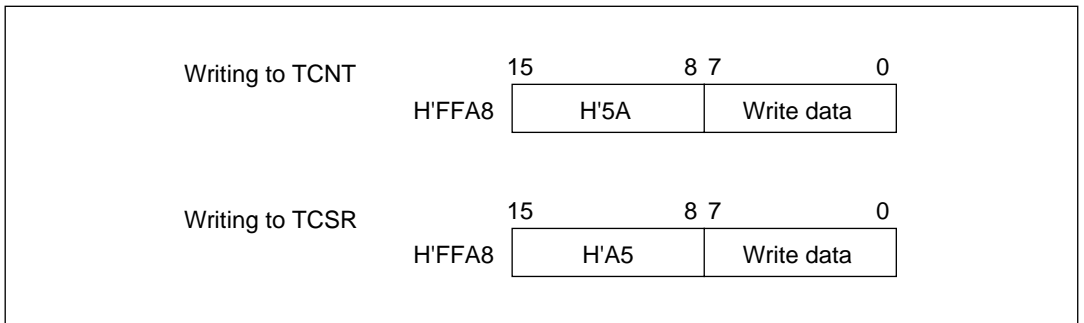

Figure 10-2 Writing to TCNT and TCSR

Reading TCNT and TCSR: The read addresses are H'FFA8 for TCSR and H'FFA9 for TCNT, as indicated in table 10-2.

These two registers are read like other registers. Byte access instructions can be used.

Table 10-2 Read Addresses of TCNT and TCSR

Read Address	Register
H'FFA8	TCSR
H'FFA9	TCNT

10.3 Operation

10.3.1 Watchdog Timer Mode

The watchdog timer function begins operating when software sets the WT/\overline{IT} and TME bits to 1 in TCSR. Thereafter, software should periodically rewrite the contents of the timer counter (normally by writing H'00) to prevent the count from overflowing. If a program crash allows the timer count to overflow, the entire chip is reset for 518 system clocks (518ϕ), or an NMI interrupt is requested. Figure 10-3 shows the operation.

NMI requests from the watchdog timer have the same vector as NMI requests from the \overline{NMI} pin. Avoid simultaneous handling of watchdog timer NMI requests and NMI requests from pin \overline{NMI} .

A reset from the watchdog timer has the same vector as an external reset from the RES pin. The reset source can be determined by the XRST bit in SYSCR.

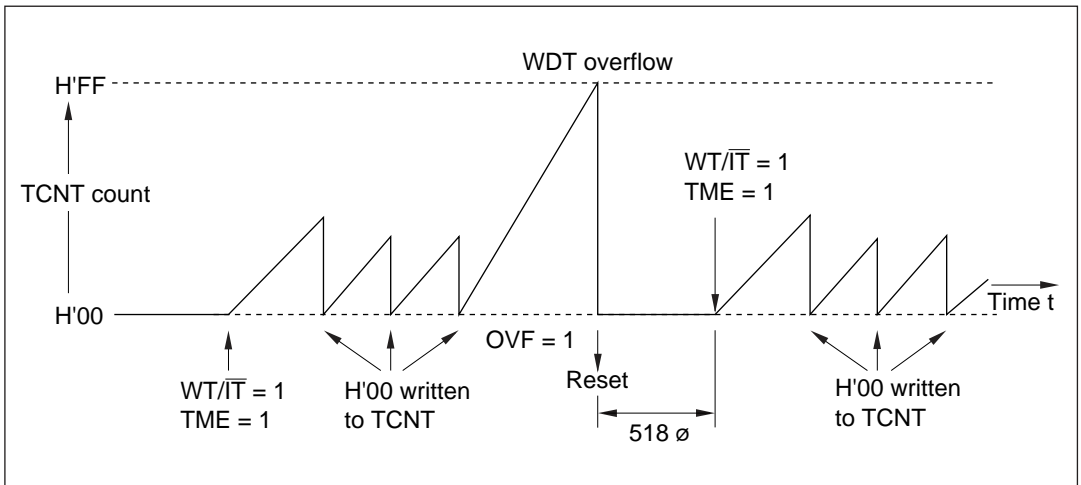

Figure 10-3 Operation in Watchdog Timer Mode

10.3.2 Interval Timer Mode

Interval timer operation begins when the $\overline{WT/\overline{IT}}$ bit is cleared to 0 and the TME bit is set to 1.

In interval timer mode, an OVF request is generated each time the timer count overflows. This function can be used to generate OVF requests at regular intervals. See figure 10-4.

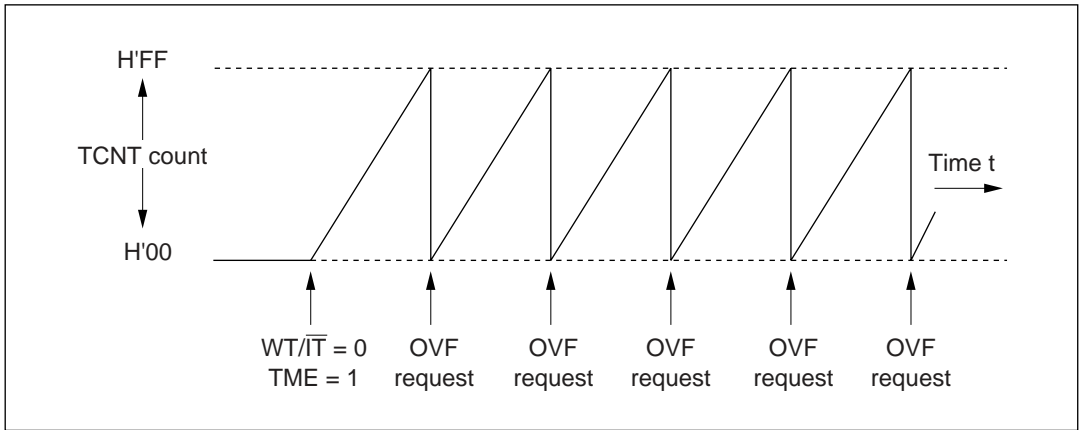

Figure 10-4 Operation in Interval Timer Mode

10.3.3 Setting the Overflow Flag

The OVF bit is set to 1 when the timer count overflows. Simultaneously, the WDT module requests an internal reset, NMI, or OVF interrupt. The timing is shown in figure 10-5.

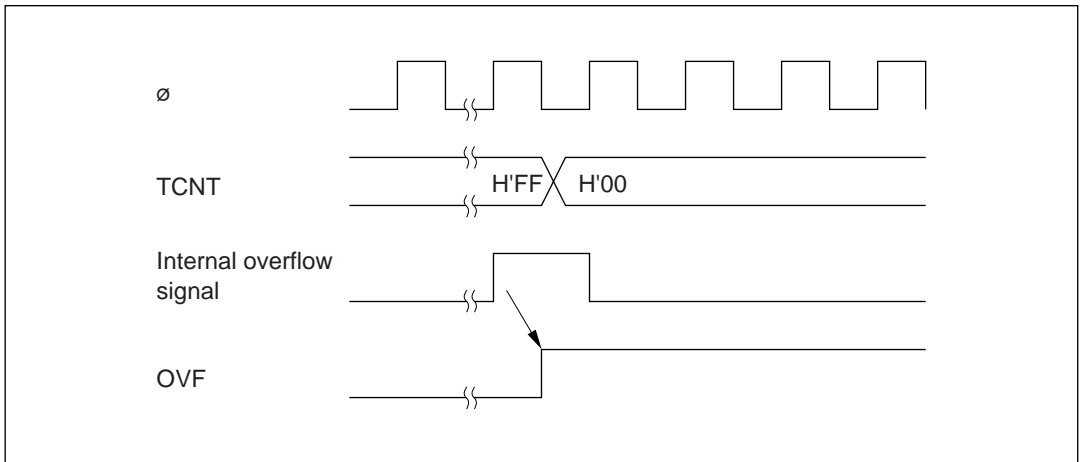

Figure 10-5 Setting the OVF Bit

10.4 Usage Notes

10.4.1 Contention between TCNT Write and Increment

If a timer counter clock pulse is generated during the T_3 state of a write cycle to the timer counter, the write takes priority and the timer counter is not incremented. See figure 10-6.

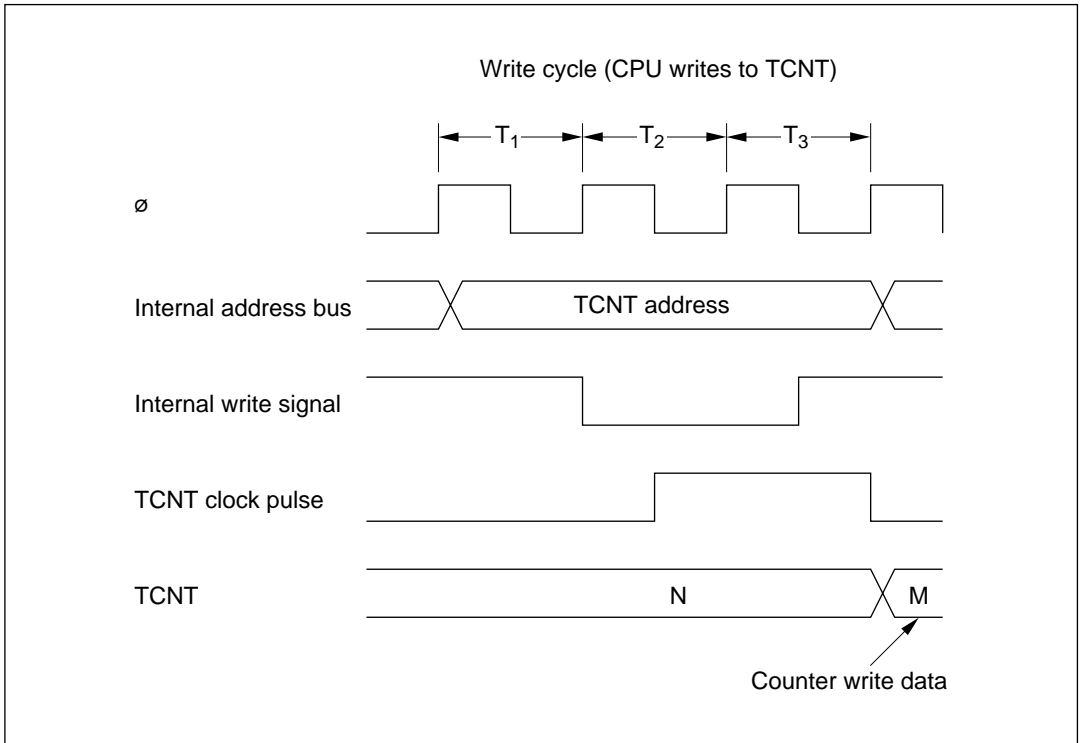

Figure 10-6 TCNT Write-Increment Contention

10.4.2 Changing the Clock Select Bits (CKS2 to CKS0)

Software should stop the watchdog timer (by clearing the TME bit to 0) before changing the value of the clock select bits. If the clock select bits are modified while the watchdog timer is running, the timer count may be incremented incorrectly.

10.4.3 Recovery from Software Standby Mode

TCSR bits, except bits 0–2, and the TCNT counter are reset when the chip recovers from software standby mode. Re-initialize the watchdog timer as necessary to resume normal operation.

Section 11 Serial Communication Interface

11.1 Overview

The H8/3297 Series includes a serial communication interface (SCI) for transferring serial data to and from other chips. Either synchronous or asynchronous communication can be selected.

11.1.1 Features

The features of the on-chip serial communication interface are:

- Asynchronous mode

The H8/3297 Series can communicate with a UART (Universal Asynchronous Receiver/Transmitter), ACIA (Asynchronous Communication Interface Adapter), or other chip that employs standard asynchronous serial communication. It also has a multiprocessor communication function for communication with other processors. Twelve data formats are available.

- Data length: 7 or 8 bits
- Stop bit length: 1 or 2 bits
- Parity: Even, odd, or none
- Multiprocessor bit: 1 or 0
- Error detection: Parity, overrun, and framing errors
- Break detection: When a framing error occurs, the break condition can be detected by reading the level of the RxD line directly.

- Synchronous mode

The SCI can communicate with chips able to perform clocked synchronous data transfer.

- Data length: 8 bits
- Error detection: Overrun errors

- Full duplex communication

The transmitting and receiving sections are independent, so each channel can transmit and receive simultaneously. Both the transmit and receive sections use double buffering, so continuous data transfer is possible in either direction.

- Built-in baud rate generator

Any specified baud rate can be generated.

- Internal or external clock source

The SCI can operate on an internal clock signal from the baud rate generator, or an external clock signal input at the SCK pin.

- Four interrupts

TDR-empty, TSR-empty, receive-end, and receive-error interrupts are requested independently.

11.1.2 Block Diagram

Figure 11-1 shows a block diagram of the serial communication interface.

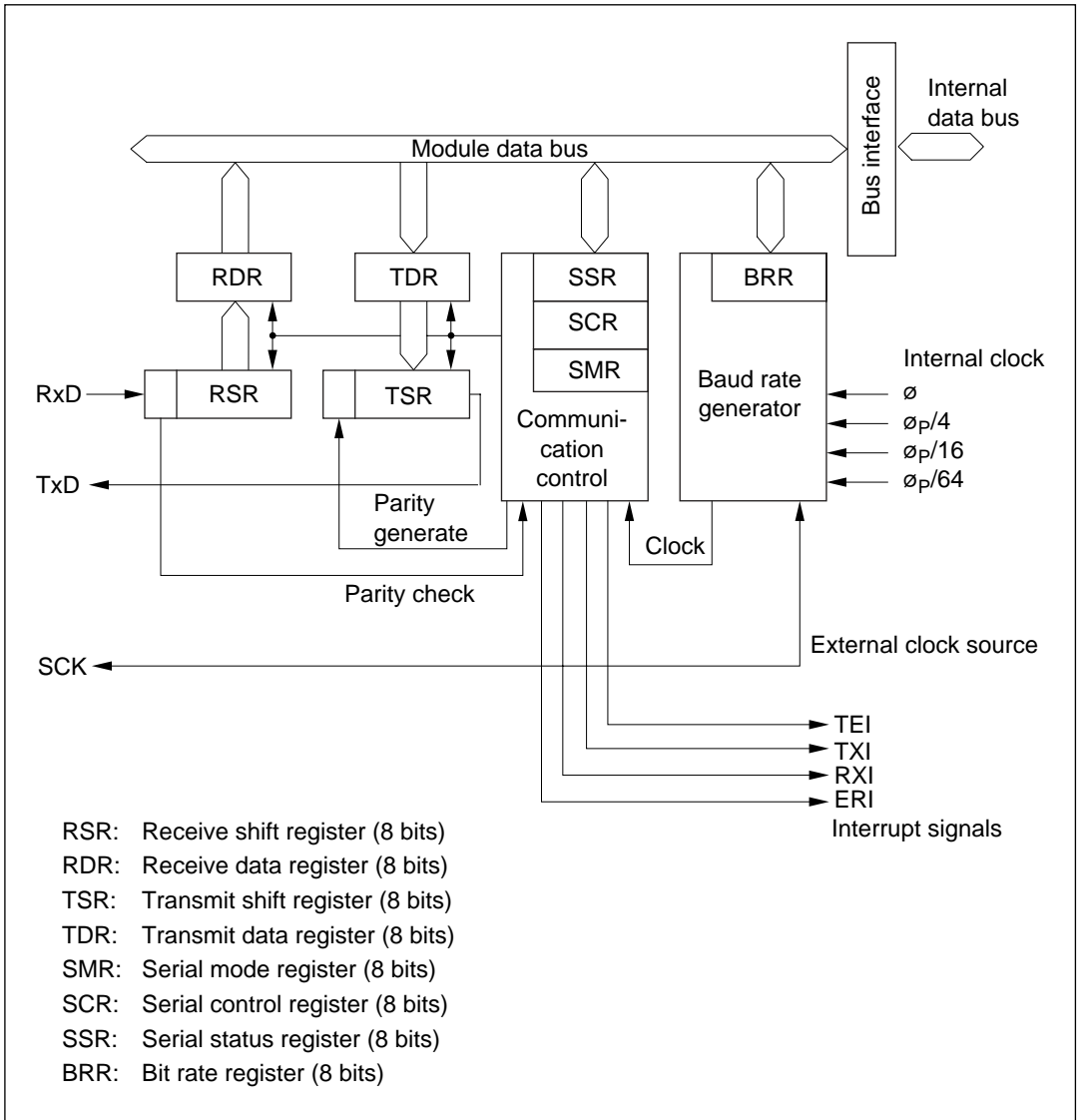

Figure 11-1 Block Diagram of Serial Communication Interface

11.1.3 Input and Output Pins

Table 11-1 lists the input and output pins used by the SCI module.

Table 11-1 SCI Input/Output Pins

Name	Abbr.	I/O	Function
Serial clock input/output	SCK	Input/output	SCI clock input and output
Receive data input	RxD	Input	SCI receive data inp
Transmit data output	TxD	Output	SCI transmit data output

11.1.4 Register Configuration

Table 11-2 lists the SCI registers. These registers specify the operating mode (synchronous or asynchronous), data format and bit rate, and control the transmit and receive sections.

Table 11-2 SCI Registers

Name	Abbr.	R/W	Value	Address
Receive shift register	RSR	—	—	—
Receive data register	RDR	R	H'00	H'FFDD
Transmit shift register	TSR	—	—	—
Transmit data register	TDR	R/W	H'FF	H'FFDB
Serial mode register	SMR	R/W	H'00	H'FFD8
Serial control register	SCR	R/W	H'00	H'FFDA
Serial status register	SSR	R/(W)*	H'84	H'FFDC
Bit rate register	BRR	R/W	H'FF	H'FFD9
Serial/timer control register	STCR	R/W	H'F8	H'FFC3

Note: * Software can write a 0 to clear the flags in bits 7 to 3, but cannot write 1 in these bits.

11.2 Register Descriptions

11.2.1 Receive Shift Register (RSR)

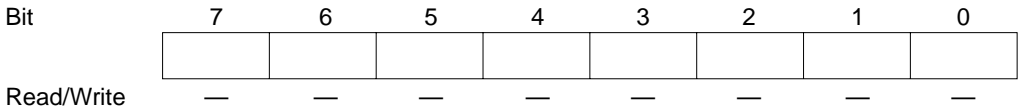

RSR is a shift register that converts incoming serial data to parallel data. When one data character has been received, it is transferred to the receive data register (RDR).

The CPU cannot read or write RSR directly.

11.2.2 Receive Data Register (RDR)



RDR stores received data. As each character is received, it is transferred from RSR to RDR, enabling RSR to receive the next character. This double-buffering allows the SCI to receive data continuously.

RDR is a read-only register. RDR is initialized to H'00 at a reset and in the standby modes.

11.2.3 Transmit Shift Register (TSR)

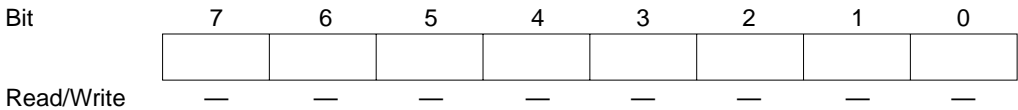

TSR is a shift register that converts parallel data to serial transmit data. When transmission of one character is completed, the next character is moved from the transmit data register (TDR) to TSR and transmission of that character begins. If the TDRE bit is still set to 1, however, nothing is transferred to TSR.

The CPU cannot read or write TSR directly.

11.2.4 Transmit Data Register (TDR)

Bit	7	6	5	4	3	2	1	0
Initial value	1	1	1	1	1	1	1	1
Read/Write	R/W	R/W	R/W	R/W	R/W	R/W	R/W	R/W

TDR is an 8-bit readable/writable register that holds the next data to be transmitted. When TSR becomes empty, the data written in TDR is transferred to TSR. Continuous data transmission is possible by writing the next data in TDR while the current data is being transmitted from TSR.

TDR is initialized to H'FF at a reset and in the standby modes.

11.2.5 Serial Mode Register (SMR)

Bit	7	6	5	4	3	2	1	0
	C/ \bar{A}	CHR	PE	O/ \bar{E}	STOP	MP	CKS1	CKS0
Initial value	0	0	0	0	0	0	0	0
Read/Write	R/W	R/W	R/W	R/W	R/W	R/W	R/W	R/W

SMR is an 8-bit readable/writable register that controls the communication format and selects the clock source of the on-chip baud rate generator. It is initialized to H'00 at a reset and in the standby modes. For further information on the SMR settings and communication formats, see tables 11-5 and 11-7 in section 11.3, Operation.

Bit 7—Communication Mode (C/ \bar{A}): This bit selects asynchronous or synchronous communication mode.

Bit 7

C/ \bar{A}	Description
0	Asynchronous communication (Initial value)
1	Synchronous communication

Bit 6—Character Length (CHR): This bit selects the character length in asynchronous mode. It is ignored in synchronous mode.

Bit 6 CHR	Description
0	8 bits per character (Initial value)
1	7 bits per character (Bits 0 to 6 of TDR and RDR are used for transmitting and receiving, respectively.)

Bit 5—Parity Enable (PE): This bit selects whether to add a parity bit in asynchronous mode. It is ignored in synchronous mode, and when a multiprocessor format is used.

Bit 5 PE	Description
0	Transmit: No parity bit is added. (Initial value) Receive: Parity is not checked.
1	Transmit: A parity bit is added. Receive: Parity is checked.

Bit 4—Parity Mode (O/\bar{E}): In asynchronous mode, when parity is enabled ($PE = 1$), this bit selects even or odd parity.

Even parity means that a parity bit is added to the data bits for each character to make the total number of 1's even. Odd parity means that the total number of 1's is made odd.

This bit is ignored when $PE = 0$, or when a multiprocessor format is used. It is also ignored in synchronous mode.

Bit 4 O/\bar{E}	Description
0	Even parity (Initial value)
1	Odd parity

Bit 3—Stop Bit Length (STOP): This bit selects the number of stop bits. It is ignored in synchronous mode.

Bit 3 STOP	Description	
0	One stop bit Transmit: One stop bit is added. Receive: One stop bit is checked to detect framing errors.	(Initial value)
1	Two stop bits Transmit: Two stop bits are added. Receive: The first stop bit is checked to detect framing errors. If the second stop bit is a space (0), it is regarded as the next start bit.	

Bit 2—Multiprocessor Mode (MP): This bit selects the multiprocessor format in asynchronous communication. When multiprocessor format is selected, the parity settings of the parity enable bit (PE) and parity mode bit (O/E) are ignored. The MP bit is ignored in synchronous communication.

The MP bit is valid only when the MPE bit in the serial/timer control register (STCR) is set to 1. When the MPE bit is cleared to 0, the multiprocessor communication function is disabled regardless of the setting of the MP bit.

Bit 2 MP	Description	
0	Multiprocessor communication function is disabled.	(Initial value)
1	Multiprocessor communication function is enabled.	

Bits 1 and 0—Clock Select 1 and 0 (CKS1 and CKS0): These bits select the clock source of the on-chip baud rate generator.

Bit 1 CKS1	Bit 0 CKS0	Description	
0	0	\emptyset clock	(Initial value)
0	1	$\emptyset_P/4$ clock	
1	0	$\emptyset_P/16$ clock	
1	1	$\emptyset_P/64$ clock	

11.2.6 Serial Control Register (SCR)

Bit	7	6	5	4	3	2	1	0
	TIE	RIE	TE	RE	MPIE	TEIE	CKE1	CKE0
Initial value	0	0	0	0	0	0	0	0
Read/Write	R/W	R/W	R/W	R/W	R/W	R/W	R/W	R/W

SCR is an 8-bit readable/writable register that enables or disables various SCI functions. It is initialized to H'00 at a reset and in the standby modes.

Bit 7—Transmit Interrupt Enable (TIE): This bit enables or disables the TDR-empty interrupt (TXI) requested when the transmit data register empty (TDRE) bit in the serial status register (SSR) is set to 1.

Bit 7

TIE	Description
0	The TDR-empty interrupt request (TxI) is disabled. (Initial value)
1	The TDR-empty interrupt request (TxI) is enabled.

Bit 6—Receive Interrupt Enable (RIE): This bit enables or disables the receive-end interrupt (RXI) requested when the receive data register full (RDRF) bit in the serial status register (SSR) is set to 1, and the receive error interrupt (ERI) requested when the overrun error (ORER), framing error (FER), or parity error (PER) bit in the serial status register (SSR) is set to 1.

Bit 6

RIE	Description
0	The receive-end interrupt (RXI) and receive-error (ERI) requests are disabled. (Initial value)
1	The receive-end interrupt (RXI) and receive-error (ERI) requests are enabled.

Bit 5—Transmit Enable (TE): This bit enables or disables the transmit function. When the transmit function is enabled, the TxD pin is automatically used for output. When the transmit function is disabled, the TxD pin can be used as a general-purpose I/O port.

Bit 5

TE	Description
0	The transmit function is disabled. The TxD pin can be used for general-purpose I/O. (Initial value)
1	The transmit function is enabled. The TxD pin is used for output.

Bit 4—Receive Enable (RE): This bit enables or disables the receive function. When the receive function is enabled, the RxD pin is automatically used for input. When the receive function is disabled, the RxD pin is available as a general-purpose I/O port.

Bit 4

RE	Description	
0	The receive function is disabled. The RxD pin can be used for general-purpose I/O.	(Initial value)
1	The receive function is enabled. The RxD pin is used for input.	

Bit 3—Multiprocessor Interrupt Enable (MPIE): When serial data is received in a multiprocessor format, this bit enables or disables the receive-end interrupt (RXI) and receive-error interrupt (ERI) until data with the multiprocessor bit set to 1 is received. It also enables or disables the transfer of received data from RSR to RDR, and enables or disables setting of the RDRF, FER, PER, and ORER bits in the serial status register (SSR).

The MPIE bit is ignored when the MP bit is cleared to 0, and in synchronous mode.

Clearing the MPIE bit to 0 disables the multiprocessor receive interrupt function. In this condition data is received regardless of the value of the multiprocessor bit in the receive data.

Setting the MPIE bit to 1 enables the multiprocessor receive interrupt function. In this condition, if the multiprocessor bit in the receive data is 0, the receive-end interrupt (RXI) and receive-error interrupt (ERI) are disabled, the receive data is not transferred from RSR to RDR, and the RDRF, FER, PER, and ORER bits in the serial status register (SSR) are not set. If the multiprocessor bit is 1, however, the MPB bit in SSR is set to 1, the MPIE bit is cleared to 0, the receive data is transferred from RSR to RDR, the FER, PER, and ORER bits can be set, and the receive-end and receive-error interrupts are enabled.

Bit 3

MPIE	Description	
0	The multiprocessor receive interrupt function is disabled. (Normal receive operation)	(Initial value)
1	The multiprocessor receive interrupt function is enabled. During the interval before data with the multiprocessor bit set to 1 is received, the receive interrupt request (Rxl) and receive-error interrupt request (ERI) are disabled, the RDRF, FER, PER, and ORER bits are not set in the serial status register (SSR), and no data is transferred from the RSR to the RDR. The MPIE bit is cleared at the following times: (1) When 0 is written in MPIE. (2) When data with the multiprocessor bit set to 1 is received.	

Bit 2—Transmit-End Interrupt Enable (TEIE): This bit enables or disables the TSR-empty interrupt (TEI) requested when the transmit-end bit (TEND) in the serial status register (SSR) is set to 1.

Bit 2

TEIE	Description	
0	The TSR-empty interrupt request (TEI) is disabled.	(Initial value)
1	The TSR-empty interrupt request (TEI) is enabled.	

Bit 1—Clock Enable 1 (CKE1): This bit selects the internal or external clock source for the baud rate generator. When the external clock source is selected, the SCK pin is automatically used for input of the external clock signal.

Bit 1

CKE1	Description	
0	Internal clock source When $C/\bar{A} = 1$, the serial clock signal is output at the SCK pin. When $C/\bar{A} = 0$, output depends on the CKE0 bit.	(Initial value)
1	External clock source. The SCK pin is used for input.	

Bit 0—Clock Enable 0 (CKE0): When an internal clock source is used in asynchronous mode, this bit enables or disables serial clock output at the SCK pin.

This bit is ignored when the external clock is selected, or when synchronous mode is selected.

For further information on the communication format and clock source selection, see table 11-6 in section 11.3, Operation.

Bit 0

CKE0	Description	
0	The SCK pin is not used by the SCI (and is available as a general-purpose I/O port).	(Initial value)
1	The SCK pin is used for serial clock output.	

11.2.7 Serial Status Register (SSR)

Bit	7	6	5	4	3	2	1	0
	TDRE	RDRF	ORER	FER	PER	TEND	MPB	MPBT
Initial value	1	0	0	0	0	1	0	0
Read/Write	R/(W)*	R/(W)*	R/(W)*	R/(W)*	R/(W)*	R	R	R/W

Note: * Software can write a 0 to clear the flags, but cannot write a 1 in these bits.

SSR is an 8-bit register that indicates transmit and receive status. It is initialized to H'84 at a reset and in the standby modes.

Bit 7—Transmit Data Register Empty (TDRE): This bit indicates when transmit data can safely be written in TDR.

Bit 7

TDRE	Description
0	To clear TDRE, the CPU must read TDRE after it has been set to 1, then write a 0 in this bit.
1	This bit is set to 1 at the following times: (Initial value) (1) When TDR contents are transferred to TSR. (2) When the TE bit in SCR is cleared to 0.

Bit 6—Receive Data Register Full (RDRF): This bit indicates when one character has been received and transferred to the RDR.

Bit 6

RDRF	Description
0	To clear RDRF, the CPU must read RDRF after it has been set to 1, then write a 0 in this bit. (Initial value)
1	This bit is set to 1 when one character is received without error and transferred from RSR to RDR.

Bit 5—Overrun Error (ORER): This bit indicates an overrun error during reception.

Bit 5 ORER	Description
0	To clear ORER, the CPU must read ORER after it has been set to 1, then write a 0 in this bit. (Initial value)
1	This bit is set to 1 if reception of the next character ends while the receive data register is still full (RDRF = 1).

Bit 4—Framing Error (FER): This bit indicates a framing error during data reception in asynchronous mode. It has no meaning in synchronous mode.

Bit 4 FER	Description
0	To clear FER, the CPU must read FER after it has been set to 1, then write a 0 in this bit. (Initial value)
1	This bit is set to 1 if a framing error occurs (stop bit = 0).

Bit 3—Parity Error (PER): This bit indicates a parity error during data reception in the asynchronous mode, when a communication format with parity bits is used.

This bit has no meaning in the synchronous mode, or when a communication format without parity bits is used.

Bit 3 PER	Description
0	To clear PER, the CPU must read PER after it has been set to 1, then write a 0 in this bit. (Initial value)
1	This bit is set to 1 when a parity error occurs (the parity of the received data does not match the parity selected by the O/E bit in SMR).

Bit 2—Transmit End (TEND): This bit indicates that the serial communication interface has stopped transmitting because there was no valid data in the TDR when the last bit of the current character was transmitted. The TEND bit is also set to 1 when the TE bit in the serial control register (SCR) is cleared to 0.

The TEND bit is a read-only bit and cannot be modified directly. To use the TEI interrupt, first start transmitting data, which clears TEND to 0, then set TEIE to 1.

Bit 2

TEND	Description	
0	To clear TEND, the CPU must read TDRE after TDRE has been set to 1, then write a 0 in TDRE	(Initial value)
1	This bit is set to 1 when: (1) TE = 0 (2) TDRE = 1 at the end of transmission of a character	

Bit 1—Multiprocessor Bit (MPB): Stores the value of the multiprocessor bit in data received in a multiprocessor format in asynchronous communication mode. This bit retains its previous value in synchronous mode, when a multiprocessor format is not used, or when the RE bit is cleared to 0 even if a multiprocessor format is used.

MPB can be read but not written.

Bit 1

MPB	Description	
0	Multiprocessor bit = 0 in receive data.	(Initial value)
1	Multiprocessor bit = 1 in receive data.	

Bit 0—Multiprocessor Bit Transfer (MPBT): Stores the value of the multiprocessor bit inserted in transmit data when a multiprocessor format is used in asynchronous communication mode. The MPBT bit is double-buffered in the same way as TSR and TDR. The MPBT bit has no effect in synchronous mode, or when a multiprocessor format is not used.

Bit 0

MPBT	Description	
0	Multiprocessor bit = 0 in transmit data.	(Initial value)
1	Multiprocessor bit = 1 in transmit data.	

11.2.8 Bit Rate Register (BRR)

Bit	7	6	5	4	3	2	1	0
Initial value	1	1	1	1	1	1	1	1
Read/Write	R/W	R/W	R/W	R/W	R/W	R/W	R/W	R/W

BRR is an 8-bit register that, together with the CKS1 and CKS0 bits in SMR, determines the baud rate output by the baud rate generator.

BRR is initialized to H'FF by a reset and in the standby modes.

Tables 11-3 and 11-4 show examples of BRR settings.

Table 11-3 Examples of BRR Settings in Asynchronous Mode (When $\phi_P = \phi$)

		ϕ Frequency (MHz)					
		2			2.097152		
Bit Rate	n	N	Error (%)	n	N	Error (%)	
110	1	141	+0.03	1	148	-0.04	
150	1	103	+0.16	1	108	+0.21	
300	0	207	+0.16	0	217	+0.21	
600	0	103	+0.16	0	108	+0.21	
1200	0	51	+0.16	0	54	-0.70	
2400	0	25	+0.16	0	26	+1.14	
4800	0	12	+0.16	0	13	-2.48	
9600	—	—	—	0	6	-2.48	
19200	—	—	—	—	—	—	
31250	0	1	0	—	—	—	
38400	—	—	—	—	—	—	

Note: If possible, the error should be within 1%.

Table 11-3 Examples of BRR Settings in Asynchronous Mode (When $\theta_P = \theta$) (cont)

Bit Rate	ϕ Frequency (MHz)											
	2.4576			3			3.6864			4		
	n	N	Error (%)	n	N	Error (%)	n	N	Error (%)	n	N	Error (%)
110	1	174	-0.26	2	52	+0.50	2	64	+0.70	2	70	+0.03
150	1	127	0	1	155	+0.16	1	191	0	1	207	+0.16
300	0	255	0	1	77	+0.16	1	95	0	1	103	+0.16
600	0	127	0	0	155	+0.16	0	191	0	0	207	+0.16
1200	0	63	0	0	77	+0.16	0	95	0	0	103	+0.16
2400	0	31	0	0	38	+0.16	0	47	0	0	51	+0.16
4800	0	15	0	0	19	-2.34	0	23	0	0	25	+0.16
9600	0	7	0	0	9	-2.34	0	11	0	0	12	+0.16
19200	0	3	0	0	4	-2.34	0	5	0	—	—	—
31250	—	—	—	0	2	0	—	—	—	0	3	0
38400	0	1	0	—	—	—	0	2	0	—	—	—

Table 11-3 Examples of BRR Settings in Asynchronous Mode (When $\theta_P = \theta$) (cont)

Bit Rate	ϕ Frequency (MHz)											
	4.9152			5			6			6.144		
	n	N	Error (%)	n	N	Error (%)	n	N	Error (%)	n	N	Error (%)
110	2	86	+0.31	2	88	-0.25	2	106	-0.44	2	108	+0.08
150	1	255	0	2	64	+0.16	2	77	0	2	79	0
300	1	127	0	1	129	+0.16	1	155	0	1	159	0
600	0	255	0	1	64	+0.16	1	77	0	1	79	0
1200	0	127	0	0	129	+0.16	0	155	+0.16	0	159	0
2400	0	63	0	0	64	+0.16	0	77	+0.16	0	79	0
4800	0	31	0	0	32	-1.36	0	38	+0.16	0	39	0
9600	0	15	0	0	15	+1.73	0	19	-2.34	0	19	0
19200	0	7	0	0	7	+1.73	0	9	-2.34	0	4	0
31250	0	4	-1.70	0	4	0	0	5	0	0	5	+2.40
38400	0	3	0	0	3	+1.73	0	4	-2.34	0	4	0

Note: If possible, the error should be within 1%.

Table 11-3 Examples of BRR Settings in Asynchronous Mode (When $\theta_p = \theta$) (cont)

Bit Rate	ϕ Frequency (MHz)											
	7.3728			8			9.8304			10		
	n	N	Error (%)	n	N	Error (%)	n	N	Error (%)	n	N	Error (%)
110	2	130	-0.07	2	141	+0.03	2	174	-0.26	3	43	+0.88
150	2	95	0	2	103	+0.16	2	127	0	2	129	+0.16
300	1	191	0	1	207	+0.16	1	255	0	2	64	+0.16
600	1	95	0	1	103	+0.16	1	127	0	1	129	+0.16
1200	0	191	0	0	207	+0.16	0	255	0	1	64	+0.16
2400	0	95	0	0	103	+0.16	0	127	0	0	129	+0.16
4800	0	47	0	0	51	+0.16	0	63	0	0	64	+0.16
9600	0	23	0	0	25	+0.16	0	31	0	0	32	-1.36
19200	0	11	0	0	12	+0.16	0	15	0	0	15	+1.73
31250	—	—	—	0	7	0	0	9	-1.70	0	9	0
38400	0	5	0	—	—	—	0	7	0	0	7	+1.73

Table 11-3 Examples of BRR Settings in Asynchronous Mode (When $\theta_p = \theta$) (cont)

Bit Rate	ϕ Frequency (MHz)											
	12			12.288			14.7456			16		
	n	N	Error (%)	n	N	Error (%)	n	N	Error (%)	n	N	Error (%)
110	2	212	+0.03	2	217	+0.08	3	64	+0.76	3	70	+0.03
150	2	155	+0.16	2	159	0	2	191	0	2	207	+0.16
300	2	77	+0.16	2	79	0	2	95	0	2	103	+0.16
600	1	155	+0.16	1	159	0	1	191	0	1	207	+0.16
1200	1	77	+0.16	1	79	0	1	95	0	1	103	+0.16
2400	0	155	+0.16	0	159	0	0	191	0	0	207	+0.16
4800	0	77	+0.16	0	79	0	0	95	0	0	103	+0.16
9600	0	38	+0.16	0	39	0	0	47	0	0	51	+0.16
19200	0	19	-2.34	0	19	0	0	23	0	0	25	+0.16
31250	0	11	0	0	11	+2.4	0	14	-1.7	0	15	0
38400	0	9	-2.34	0	9	0	0	11	0	0	12	+0.16

Note: If possible, the error should be within 1%.

$$B = F \times 10^6 / [64 \times 2^{2n-1} \times (N + 1)] \rightarrow N = F \times 10^6 / [64 \times 2^{2n-1} \times B] - 1$$

B: Baud rate (bits/second)

N: BRR value ($0 \leq N \leq 255$)

F: ϕ_P (MHz) when $n \neq 0$, or ϕ (MHz) when $n = 0$

n: Internal clock source (0, 1, 2, or 3)

The meaning of n is given by the table below:

n	CKS1	CKS0	Clock
0	0	0	ϕ
1	0	1	$\phi_P/4$
2	1	0	$\phi_P/16$
3	1	1	$\phi_P/64$

Bit rate error can be calculated with the formula below.

$$\text{Error (\%)} = \left\{ \frac{F \times 10^6}{(N + 1) \times B \times 64 \times 2^{2n-1}} - 1 \right\} \times 100$$

Table 11-4 Examples of BRR Settings in Synchronous Mode (When $\phi_P = \phi$)

Bit Rate	ϕ Frequency (MHz)											
	2		4		5		8		10		16	
	n	N	n	N	n	N	n	N	n	N	n	N
100	—	—	—	—	—	—	—	—	—	—	—	—
250	2	124	2	249	—	—	3	124	—	—	3	249
500	1	249	2	124	—	—	2	249	—	—	3	124
1 k	1	124	1	249	—	—	2	124	—	—	2	249
2.5 k	0	199	1	99	1	124	1	199	1	249	2	99
5 k	0	99	0	199	0	249	1	99	1	124	1	199
10 k	0	49	0	99	0	124	0	199	0	249	1	99
25 k	0	19	0	39	0	49	0	79	0	99	0	159
50 k	0	9	0	19	0	24	0	39	0	49	0	79
100 k	0	4	0	9	—	—	0	19	0	24	0	39
250 k	0	1	0	3	0	4	0	7	0	9	0	15
500 k	0	0*	0	1	—	—	0	3	0	4	0	7
1 M			0	0*	—	—	0	1	—	—	0	3
2.5 M									0	0*	—	—
4 M											0	0*

Blank: No setting is available.

—: A setting is available, but the bit rate is inaccurate.

*: Continuous transfer is not possible.

$$B = F \times 10^6 / [8 \times 2^{2n} \times (N + 1)] \rightarrow N = F \times 10^6 / [8 \times 2^{2n-1} \times B] - 1$$

B: Baud rate (bits per second)

N: BRR value ($0 \leq N \leq 255$)

F: ϕ_P (MHz) when $n \neq 0$, or ϕ (MHz) when $n = 0$

n: Internal clock source (0, 1, 2, or 3)

The meaning of n is given by the table below:

n	CKS1	CKS0	Clock
0	0	0	ϕ
1	0	1	$\phi_P/4$
2	1	0	$\phi_P/16$
3	1	1	$\phi_P/64$

11.2.9 Serial/Timer Control Register (STCR)

Bit	7	6	5	4	3	2	1	0
	—	—	—	—	—	MPE	ICKS1	ICKS0
Initial value	1	1	1	1	1	0	0	0
Read/Write	—	—	—	—	—	R/W	R/W	R/W

STCR is an 8-bit readable/writable register that controls the SCI operating mode and selects the TCNT clock source in the 8-bit timers. STCR is initialized to H'F8 by a reset.

Bits 7 to 3—Reserved: These bits cannot be modified, and are always read as 1.

Bit 2—Multiprocessor Enable (MPE): Enables or disables the multiprocessor communication function on channels SCI0 and SCI1.

Bit 2

MPE	Description
0	The multiprocessor communication function is disabled, (Initial value) regardless of the setting of the MP bit in SMR.
1	The multiprocessor communication function is enabled. The multi-processor format can be selected by setting the MP bit in SMR to 1.

Bits 1 and 0—Internal Clock Source Select 1 and 0 (ICKS1, ICKS0): These bits select the clock input to the timer counters (TCNT) in the 8-bit timers. For details, see section 9, 8-Bit Timers.

11.3 Operation

11.3.1 Overview

The SCI supports serial data transfer in two modes. In asynchronous mode each character is synchronized individually. In synchronous mode communication is synchronized with a clock signal.

The selection of asynchronous or synchronous mode and the communication format depend on SMR settings as indicated in table 11-5. The clock source depends on the settings of the C/A bit in the SMR and the CKE1 and CKE0 bits in SCR as indicated in table 11-6.

Asynchronous Mode

- Data length: 7 or 8 bits can be selected.
- A parity bit or multiprocessor bit can be added, and stop bit lengths of 1 or 2 bits can be selected. (These selections determine the communication format and character length.)
- Framing errors (FER), parity errors (PER), and overrun errors (ORER) can be detected in receive data, and the line-break condition can be detected.
- SCI clock source: an internal or external clock source can be selected.
- Internal clock: The SCI is clocked by the on-chip baud rate generator and can output a clock signal at the bit-rate frequency.
- External clock: The external clock frequency must be 16 times the bit rate. (The on-chip baud rate generator is not used.)

Synchronous Mode

- Communication format: The data length is 8 bits.
- Overrun errors (ORER) can be detected in receive data.
- SCI clock source: an internal or external clock source can be selected.
- Internal clock: The SCI is clocked by the on-chip baud rate generator and outputs a serial clock signal to external devices.
- External clock: The on-chip baud rate generator is not used. The SCI operates on the input serial clock.

Table 11-5 Communication Formats Used by SCI

SMR Settings						Communication Format					
Bit 7 C/A	Bit 6 CHR	Bit 2 MP	Bit 5 PE	Bit 3 STOP	Mode	Data Length	Multi-processor Bit	Parity Bit	Stop-Bit Length		
0	0	0	0	0	Asynchronous mode	8 bits	None	None	1 bit		
				1					2 bits		
				1					0	Present	1 bit
				1					2 bits		
				1					0	None	1 bit
				1					2 bits		
	1	0	0	0	Asynchronous mode (multi-processor format)	7 bits	Present	None	1 bit		
				1					2 bits		
				1					0	Present	1 bit
				1					2 bits		
				1					0	None	1 bit
				1					2 bits		
1	—	—	—	—	Synchronous mode	8 bits	None	None	None		

Table 11-6 SCI Clock Source Selection

SMR	SCR		Mode	Serial Transmit/Receive Clock	
Bit 7 C/A	Bit 1 CKE1	Bit 0 CKE0		Clock Source	SCK Pin Function
0	0	0	Async	Internal	Input/output port (not used by SCI)
		1			Serial clock output at bit rate
	1	0		External	Serial clock input at 16 × bit rate
		1			
1	0	0	Sync	Internal	Serial clock output
		1			
	1	0		External	Serial clock input
		1			

11.3.2 Asynchronous Mode

In asynchronous mode, each transmitted or received character is individually synchronized by framing it with a start bit and stop bit.

Full duplex data transfer is possible because the SCI has independent transmit and receive sections. Double buffering in both sections enables the SCI to be programmed for continuous data transfer.

Figure 11-2 shows the general format of one character sent or received in asynchronous mode. The communication channel is normally held in the mark state (high). Character transmission or reception starts with a transition to the space state (low).

The first bit transmitted or received is the start bit (low). It is followed by the data bits, in which the least significant bit (LSB) comes first. The data bits are followed by the parity or multiprocessor bit, if present, then the stop bit or bits (high) confirming the end of the frame.

In receiving, the SCI synchronizes on the falling edge of the start bit, and samples each bit at the center of the bit (at the 8th cycle of the internal serial clock, which runs at 16 times the bit rate).

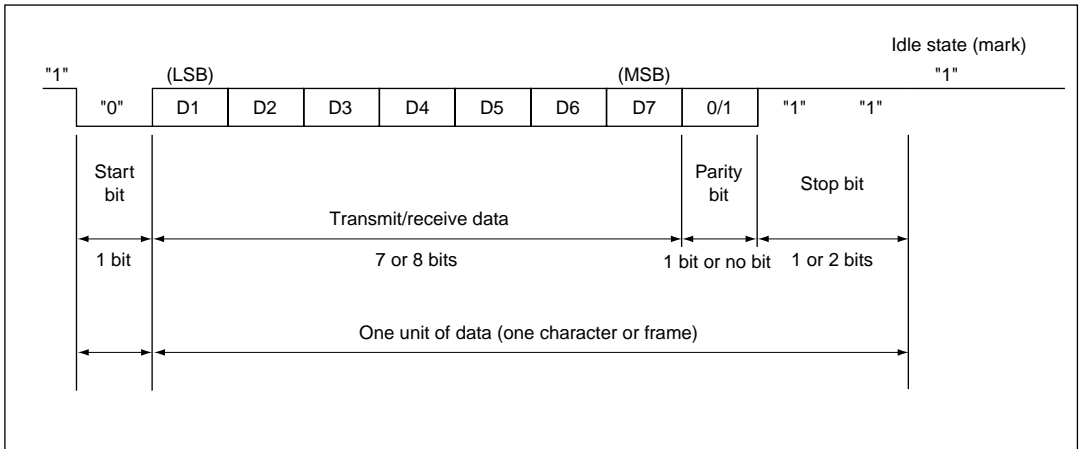

**Figure 11-2 Data Format in Asynchronous Mode
(Example of 8-Bit Data with Parity Bit and Two Stop Bits)**

(1) Data Format: Table 11-7 lists the data formats that can be sent and received in asynchronous mode. Twelve formats can be selected by bits in the serial mode register (SMR).

Table 11-7 Data Formats in Asynchronous Mode

SMR Bits				1	2	3	4	5	6	7	8	9	10	11	12
CHR	PE	MP	STOP												
0	0	0	0	S	8-bit data								STOP		
0	0	0	1	S	8-bit data								STOP	STOP	
0	1	0	0	S	8-bit data								P	STOP	
0	1	0	1	S	8-bit data								P	STOP	STOP
1	0	0	0	S	7-bit data							STOP			
1	0	0	1	S	7-bit data							STOP	STOP		
1	1	0	0	S	7-bit data							P	STOP		
1	1	0	1	S	7-bit data							P	STOP	STOP	
0	—	1	0	S	8-bit data								MPB	STOP	
0	—	1	1	S	8-bit data								MPB	STOP	STOP
1	—	1	0	S	7-bit data							MPB	STOP		
1	—	1	1	S	7-bit data							MPB	STOP	STOP	

Notes: SMR: Serial mode register
 S: Start bit
 STOP: Stop bit
 P: Parity bit
 MPB: Multiprocessor bit

(2) Clock: In asynchronous mode it is possible to select either an internal clock created by the on-chip baud rate generator, or an external clock input at the SCK pin. The selection is made by the C/A bit in the serial mode register (SMR) and the CKE1 and CKE0 bits in the serial control register (SCR). Refer to table 11-6.

If an external clock is input at the SCK pin, its frequency should be 16 times the desired bit rate.

If the internal clock provided by the on-chip baud rate generator is selected and the SCK pin is used for clock output, the output clock frequency is equal to the bit rate, and the clock pulse rises at the center of the transmit data bits. Figure 11-3 shows the phase relationship between the output clock and transmit data.

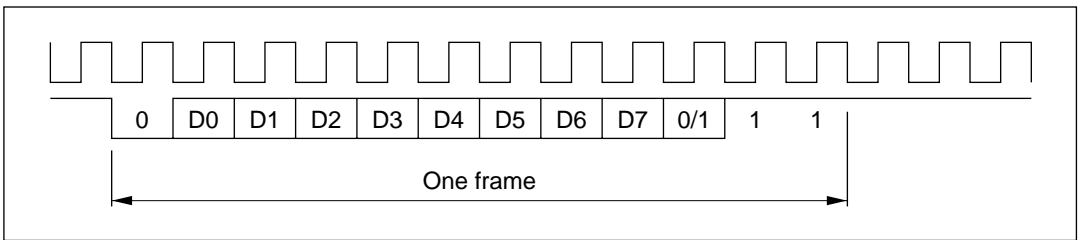

Figure 11-3 Phase Relationship between Clock Output and Transmit Data (Asynchronous Mode)

(3) Transmitting and Receiving Data

- **SCI Initialization:** Before transmitting or receiving, software must clear the TE and RE bits to 0 in the serial control register (SCR), then initialize the SCI following the procedure in figure 11-4.

Note: When changing the communication mode or format, always clear the TE and RE bits to 0 before following the procedure given below. Clearing TE to 0 sets TDRE to 1 and initializes the transmit shift register (TSR). Clearing RE to 0, however, does not initialize the RDRF, PER, FER, and ORER flags and receive data register (RDR), which retain their previous contents.

When an external clock is used, the clock should not be stopped during initialization or subsequent operation. SCI operation becomes unreliable if the clock is stopped.

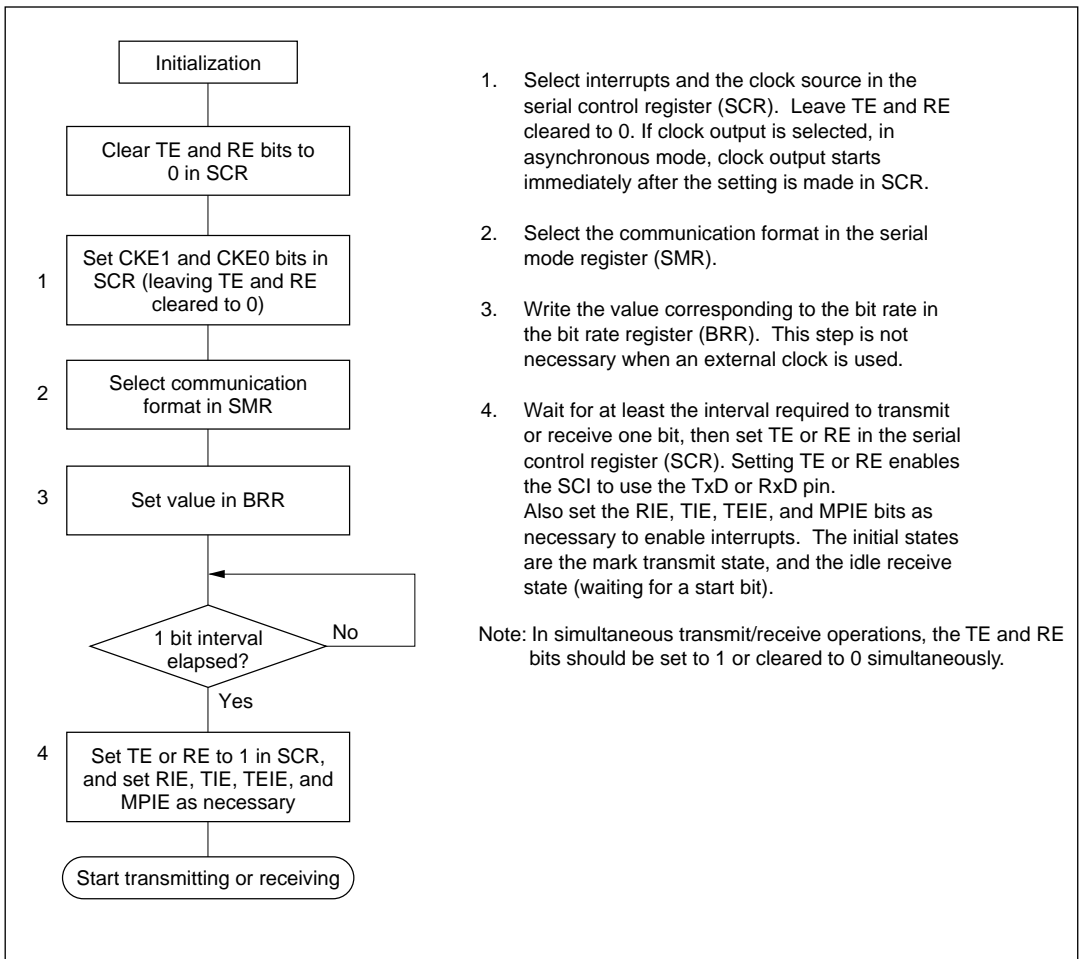

1. Select interrupts and the clock source in the serial control register (SCR). Leave TE and RE cleared to 0. If clock output is selected, in asynchronous mode, clock output starts immediately after the setting is made in SCR.
2. Select the communication format in the serial mode register (SMR).
3. Write the value corresponding to the bit rate in the bit rate register (BRR). This step is not necessary when an external clock is used.
4. Wait for at least the interval required to transmit or receive one bit, then set TE or RE in the serial control register (SCR). Setting TE or RE enables the SCI to use the TxD or RxD pin. Also set the RIE, TIE, TEIE, and MPIE bits as necessary to enable interrupts. The initial states are the mark transmit state, and the idle receive state (waiting for a start bit).

Note: In simultaneous transmit/receive operations, the TE and RE bits should be set to 1 or cleared to 0 simultaneously.

Figure 11-4 Sample Flowchart for SCI Initialization

- **Transmitting Serial Data:** Follow the procedure in figure 11-5 for transmitting serial data.

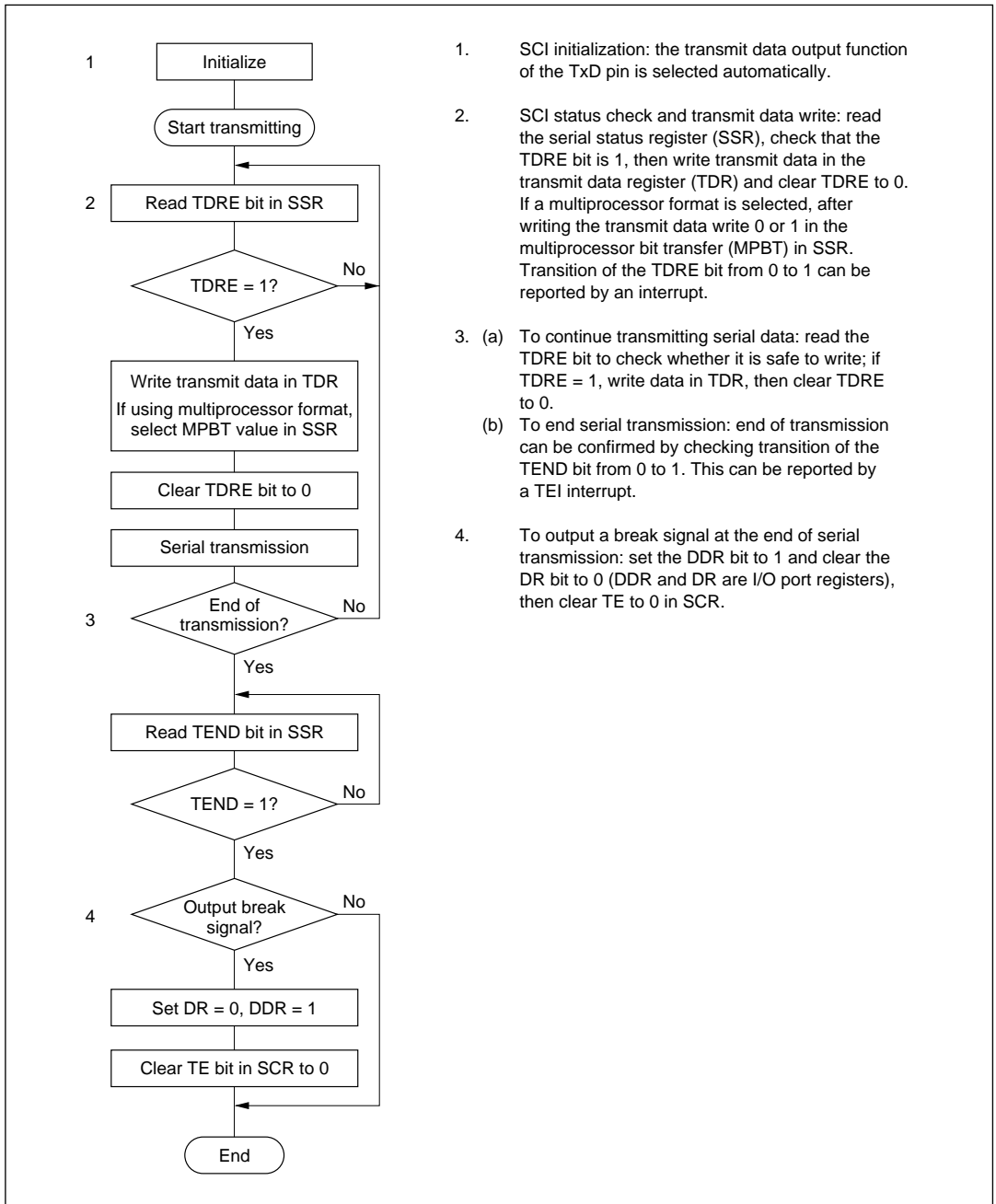

1. SCI initialization: the transmit data output function of the TxD pin is selected automatically.
2. SCI status check and transmit data write: read the serial status register (SSR), check that the TDRE bit is 1, then write transmit data in the transmit data register (TDR) and clear TDRE to 0. If a multiprocessor format is selected, after writing the transmit data write 0 or 1 in the multiprocessor bit transfer (MPBT) in SSR. Transition of the TDRE bit from 0 to 1 can be reported by an interrupt.
3. (a) To continue transmitting serial data: read the TDRE bit to check whether it is safe to write; if TDRE = 1, write data in TDR, then clear TDRE to 0.
(b) To end serial transmission: end of transmission can be confirmed by checking transition of the TEND bit from 0 to 1. This can be reported by a TEI interrupt.
4. To output a break signal at the end of serial transmission: set the DDR bit to 1 and clear the DR bit to 0 (DDR and DR are I/O port registers), then clear TE to 0 in SCR.

Figure 11-5 Sample Flowchart for Transmitting Serial Data

In transmitting serial data, the SCI operates as follows.

1. The SCI monitors the TDRE bit in SSR. When TDRE is cleared to 0 the SCI recognizes that the transmit data register (TDR) contains new data, and loads this data from TDR into the transmit shift register (TSR).
2. After loading the data from TDR into TSR, the SCI sets the TDRE bit to 1 and starts transmitting. If the TIE bit (TDR-empty interrupt enable) is set to 1 in SCR, the SCI requests a TXI interrupt (TDR-empty interrupt) at this time.

Serial transmit data are transmitted in the following order from the TxD pin:

- (a) Start bit: one 0 bit is output.
 - (b) Transmit data: seven or eight bits are output, LSB first.
 - (c) Parity bit or multiprocessor bit: one parity bit (even or odd parity) or one multiprocessor bit is output. Formats in which neither a parity bit nor a multiprocessor bit is output can also be selected.
 - (d) Stop bit: one or two 1 bits (stop bits) are output.
 - (e) Mark state: output of 1 bits continues until the start bit of the next transmit data.
3. The SCI checks the TDRE bit when it outputs the stop bit. If TDRE is 0, after loading new data from TDR into TSR and transmitting the stop bit, the SCI begins serial transmission of the next frame. If TDRE is 1, after setting the TEND bit to 1 in SSR and transmitting the stop bit, the SCI continues 1-level output in the mark state, and if the TEIE bit (TSR-empty interrupt enable) in SCR is set to 1, the SCI generates a TEI interrupt request (TSR-empty interrupt).

Figure 11-6 shows an example of SCI transmit operation in asynchronous mode.

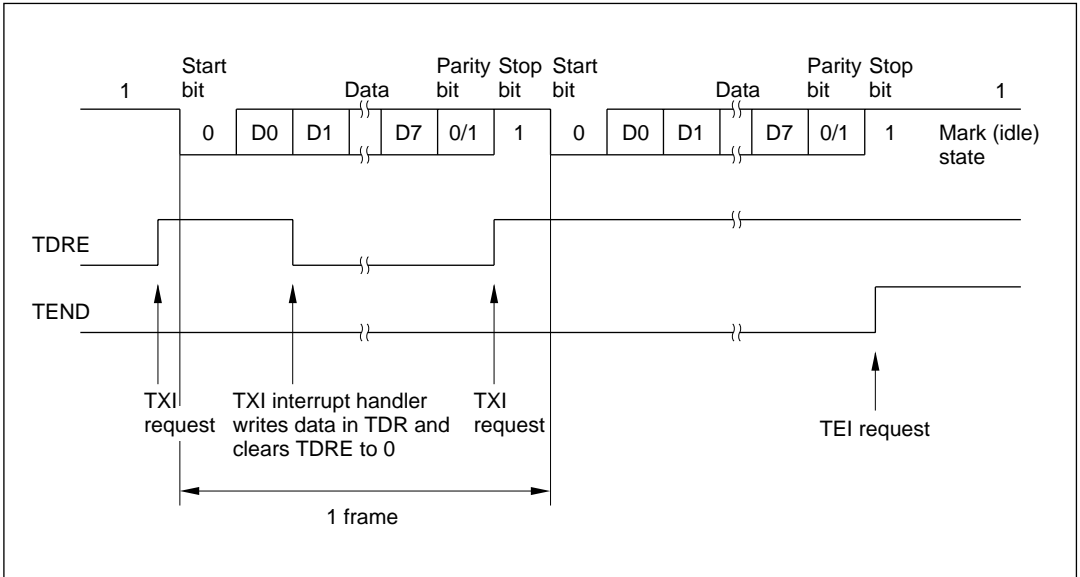

**Figure 11-6 Example of SCI Transmit Operation
(8-Bit Data with Parity and One Stop Bit)**

- **Receiving Serial Data:** Follow the procedure in figure 11-7 for receiving serial data.

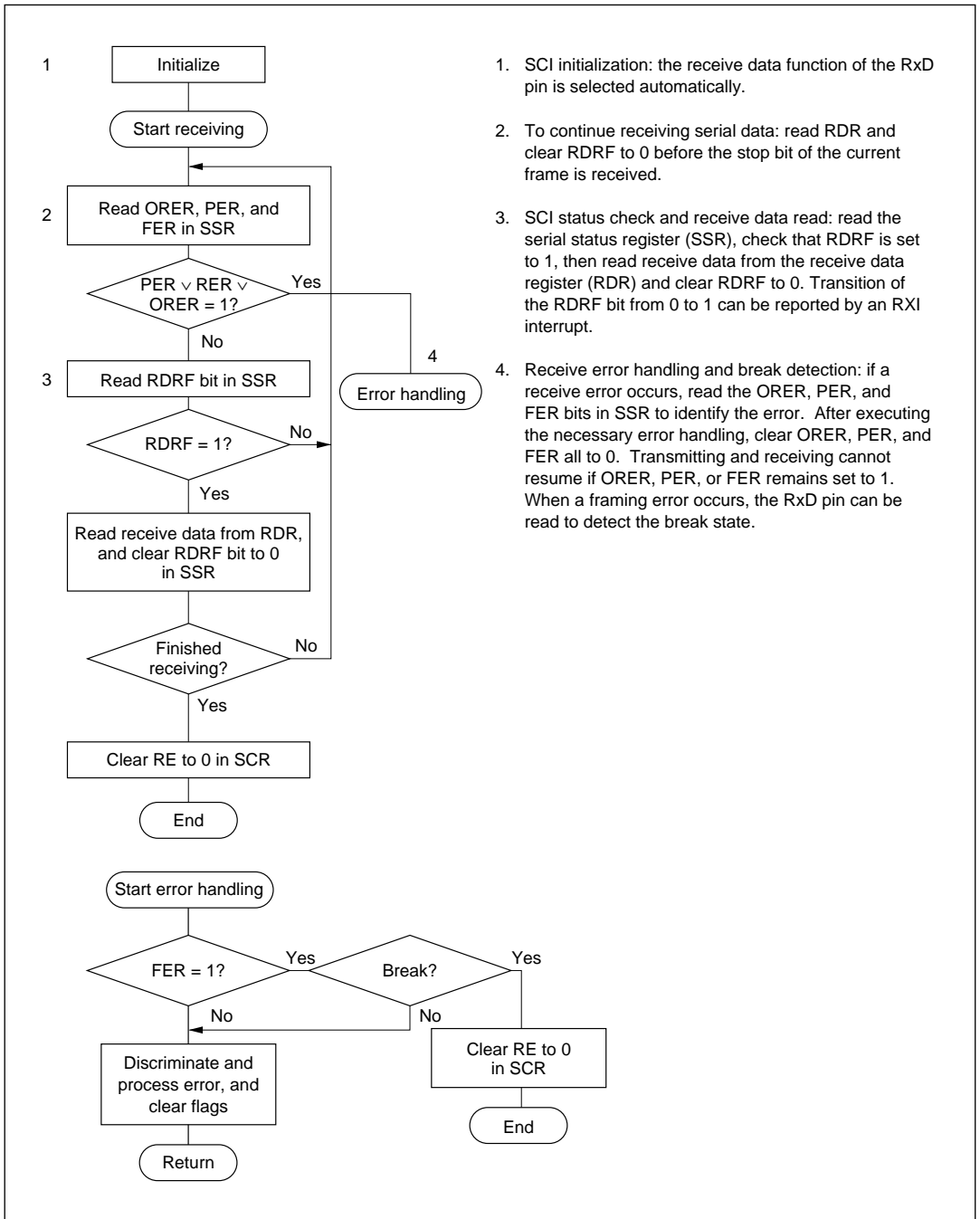

1. SCI initialization: the receive data function of the RxD pin is selected automatically.
2. To continue receiving serial data: read RDR and clear RDRF to 0 before the stop bit of the current frame is received.
3. SCI status check and receive data read: read the serial status register (SSR), check that RDRF is set to 1, then read receive data from the receive data register (RDR) and clear RDRF to 0. Transition of the RDRF bit from 0 to 1 can be reported by an RXI interrupt.
4. Receive error handling and break detection: if a receive error occurs, read the ORER, PER, and FER bits in SSR to identify the error. After executing the necessary error handling, clear ORER, PER, and FER all to 0. Transmitting and receiving cannot resume if ORER, PER, or FER remains set to 1. When a framing error occurs, the RxD pin can be read to detect the break state.

Figure 11-7 Sample Flowchart for Receiving Serial Data

In receiving, the SCI operates as follows.

1. The SCI monitors the receive data line and synchronizes internally when it detects a start bit.
2. Receive data is shifted into RSR in order from LSB to MSB.
3. The parity bit and stop bit are received.

After receiving these bits, the SCI makes the following checks:

- (a) Parity check: the number of 1s in the receive data must match the even or odd parity setting of the O/E bit in SMR.
- (b) Stop bit check: the stop bit value must be 1. If there are two stop bits, only the first stop bit is checked.
- (c) Status check: RDRF must be 0 so that receive data can be loaded from RSR into RDR.

If these checks all pass, the SCI sets RDRF to 1 and stores the received data in RDR. If one of the checks fails (receive error), the SCI operates as indicated in table 11-8.

Note: When a receive error flag is set, further receiving is disabled. The RDRF bit is not set to 1. Be sure to clear the error flags.

4. After setting RDRF to 1, if the RIE bit (receive-end interrupt enable) is set to 1 in SCR, the SCI requests an RXI (receive-end) interrupt. If one of the error flags (ORER, PER, or FER) is set to 1 and the RIE bit in SCR is also set to 1, the SCI requests an ERI (receive-error) interrupt.

Figure 11-8 shows an example of SCI receive operation in asynchronous mode.

Table 11-8 Receive Error Conditions and SCI Operation

Receive error	Abbreviation	Condition	Data Transfer
Overrun error	ORER	Receiving of next data ends while RDRF is still set to 1 in SSR	Receive data not loaded from RSR into RDR
Framing error	FER	Stop bit is 0	Receive data loaded from RSR into RDR
Parity error	PER	Parity of receive data differs from even/odd parity setting in SMR	Receive data loaded from RSR into RDR

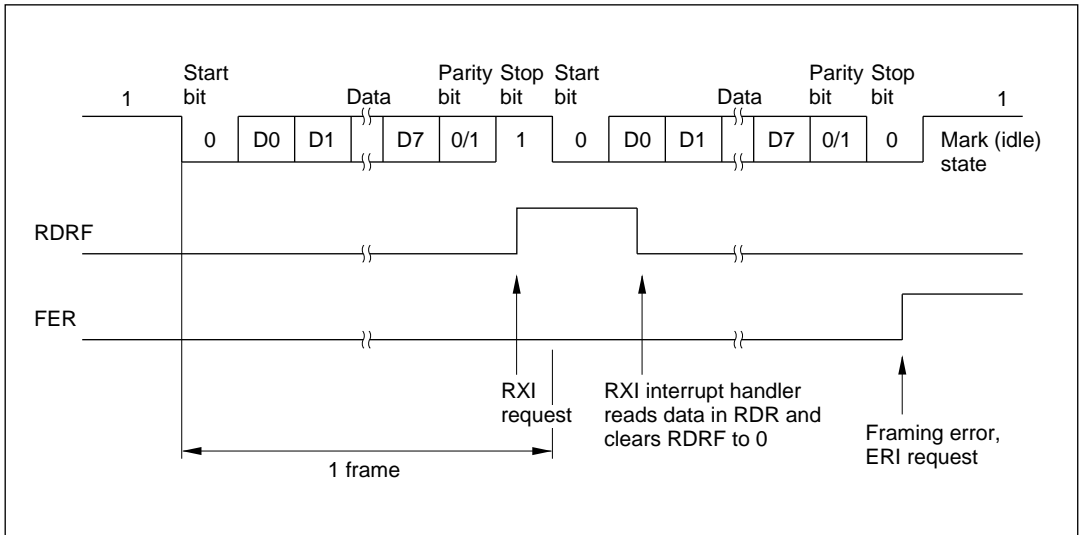

Figure 11-8 Example of SCI Receive Operation (8-Bit Data with Parity and One Stop Bit)

(4) Multiprocessor Communication

The multiprocessor communication function enables several processors to share a single serial communication line. The processors communicate in asynchronous mode using a format with an additional multiprocessor bit (multiprocessor format).

In multiprocessor communication, each receiving processor is addressed by an ID.

A serial communication cycle consists of two cycles: an ID-sending cycle that identifies the receiving processor, and a data-sending cycle. The multiprocessor bit distinguishes ID-sending cycles from data-sending cycles.

The transmitting processor starts by sending the ID of the receiving processor with which it wants to communicate as data with the multiprocessor bit set to 1. Next the transmitting processor sends transmit data with the multiprocessor bit cleared to 0.

Receiving processors skip incoming data until they receive data with the multiprocessor bit set to 1.

After receiving data with the multiprocessor bit set to 1, the receiving processor with an ID matching the received data continues to receive further incoming data. Multiple processors can send and receive data in this way.

Four formats are available. Parity-bit settings are ignored when a multiprocessor format is selected. For details see table 11-7.

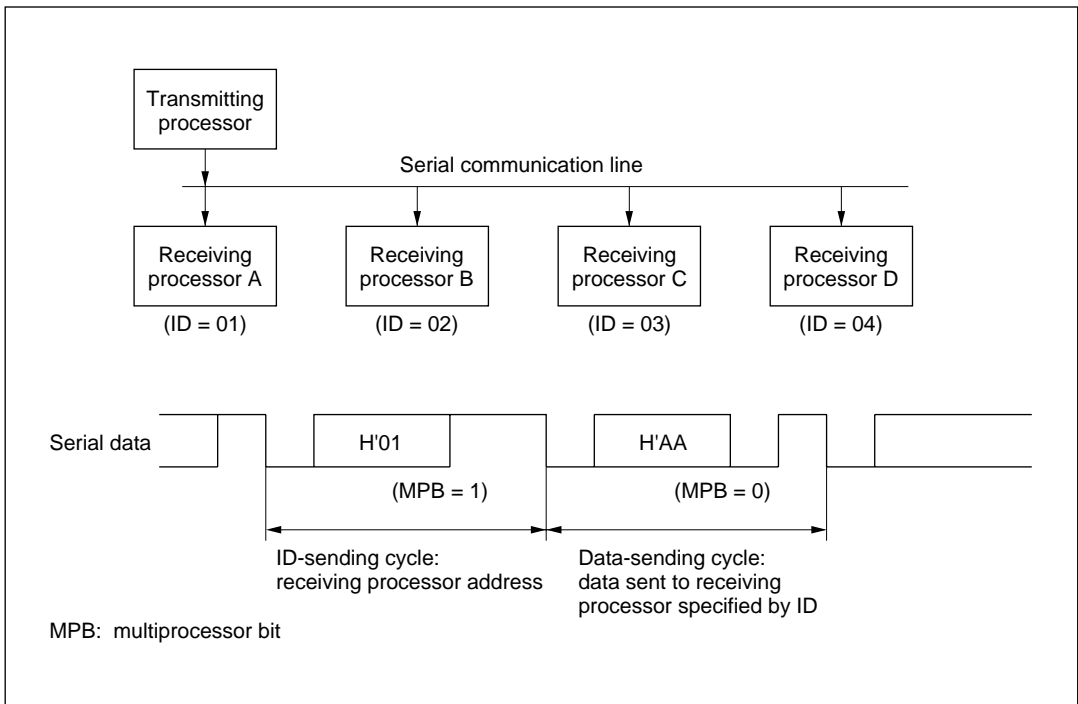

Figure 11-9 Example of Communication among Processors using Multiprocessor Format (Sending Data H'AA to Receiving Processor A)

- **Transmitting Multiprocessor Serial Data:** See figures 11-5 and 11-6.

- **Receiving Multiprocessor Serial Data:** Follow the procedure in figure 11-10 for receiving multiprocessor serial data.

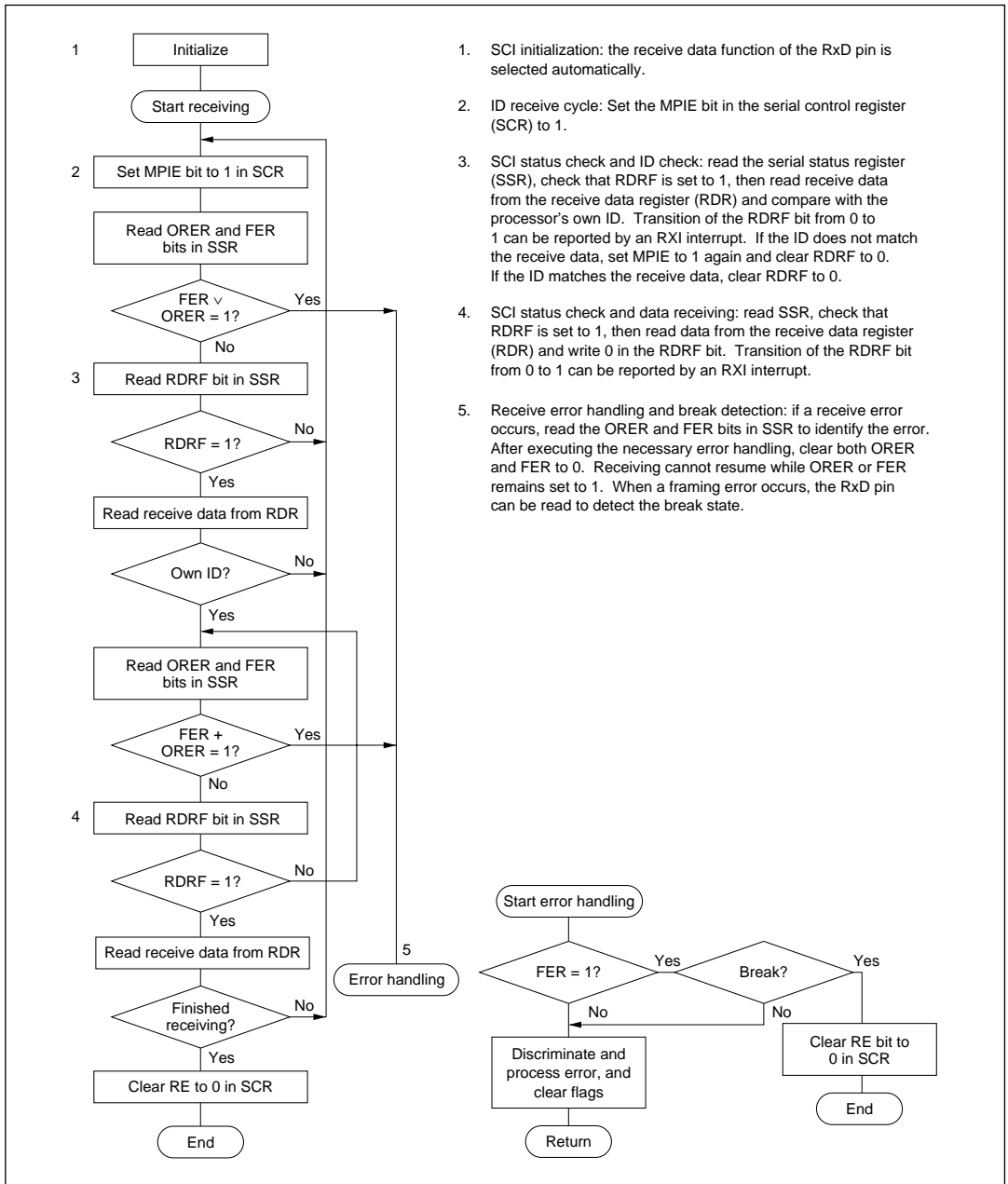

Figure 11-10 Sample Flowchart for Receiving Multiprocessor Serial Data

Figure 11-11 shows an example of an SCI receive operation using a multiprocessor format (8-bit data with multiprocessor bit and one stop bit).

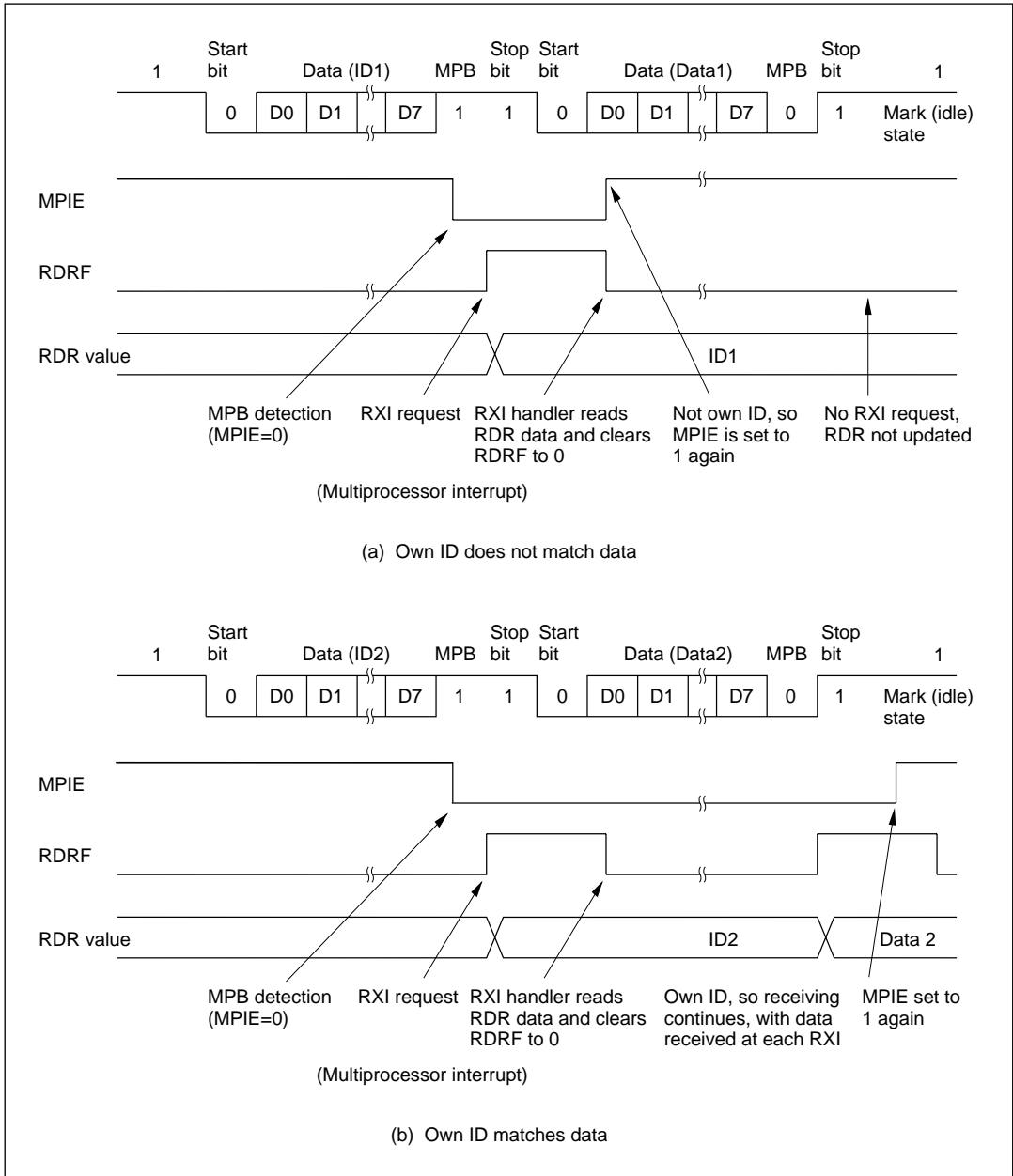

Figure 11-11 Example of SCI Receive Operation (8-Bit Data with Multiprocessor Bit and One Stop Bit)

- **Communication Format:** The data length is fixed at eight bits. No parity bit or multiprocessor bit can be added.
- **Clock:** An internal clock generated by the on-chip baud rate generator or an external clock input from the SCK pin can be selected by clearing or setting the CKE1 bit in the serial control register (SCR). See table 11-6.

When the SCI operates on an internal clock, it outputs the clock signal at the SCK pin. Eight clock pulses are output per transmitted or received character. When the SCI is not transmitting or receiving, the clock signal remains at the high level.

(2) Transmitting and Receiving Data

- **SCI Initialization:** The SCI must be initialized in the same way as in asynchronous mode. See figure 11-4. When switching from asynchronous mode to synchronous mode, check that the ORER, FER, and PER bits are cleared to 0. Transmitting and receiving cannot begin if ORER, FER, or PER is set to 1.

- **Transmitting Serial Data:** Follow the procedure in figure 11-13 for transmitting serial data.

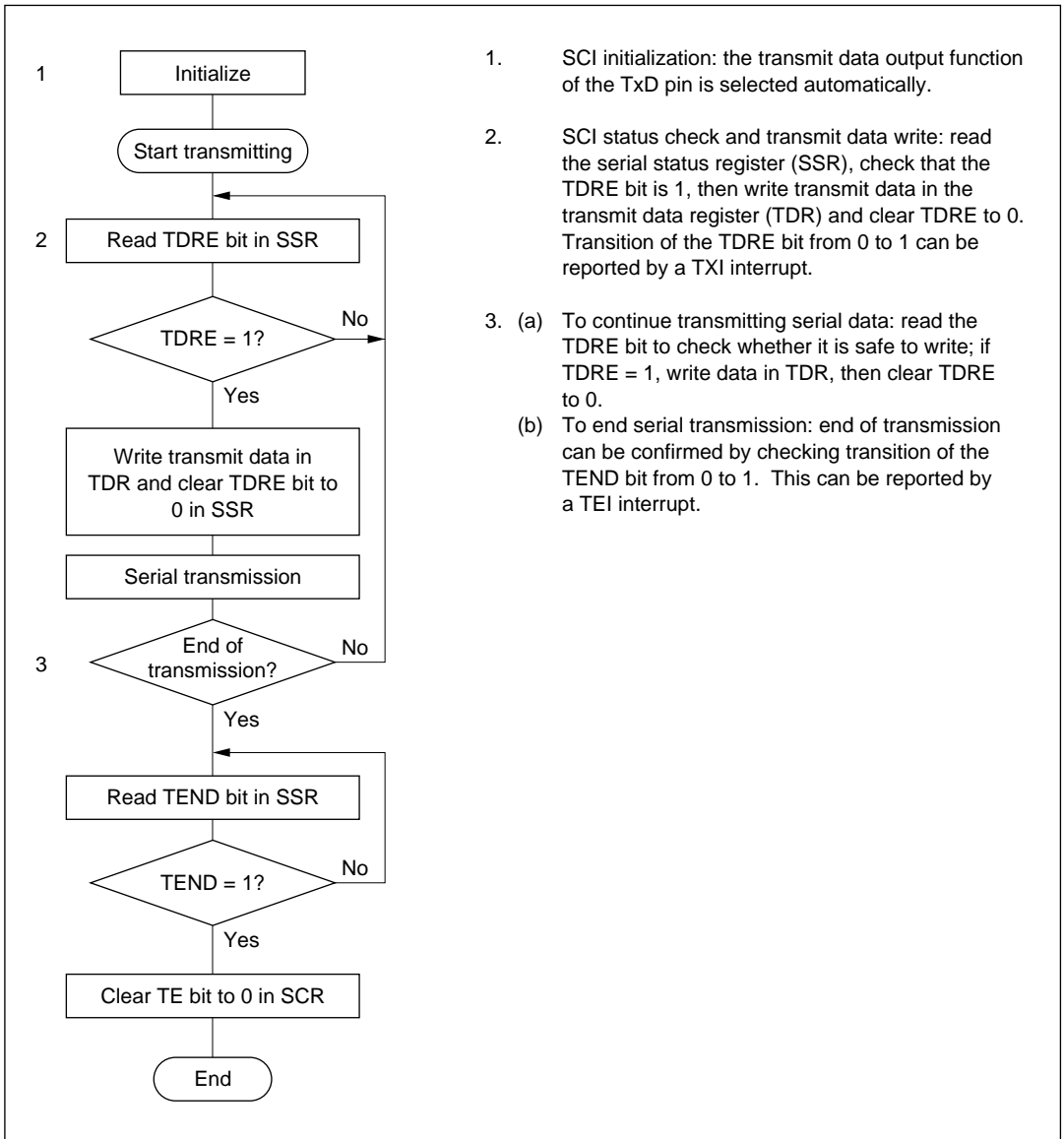

1. SCI initialization: the transmit data output function of the TxD pin is selected automatically.
2. SCI status check and transmit data write: read the serial status register (SSR), check that the TDRE bit is 1, then write transmit data in the transmit data register (TDR) and clear TDRE to 0. Transition of the TDRE bit from 0 to 1 can be reported by a TXI interrupt.
3. (a) To continue transmitting serial data: read the TDRE bit to check whether it is safe to write; if TDRE = 1, write data in TDR, then clear TDRE to 0.
(b) To end serial transmission: end of transmission can be confirmed by checking transition of the TEND bit from 0 to 1. This can be reported by a TEI interrupt.

Figure 11-13 Sample Flowchart for Serial Transmitting

In transmitting serial data, the SCI operates as follows.

1. The SCI monitors the TDRE bit in SSR. When TDRE is cleared to 0 the SCI recognizes that the transmit data register (TDR) contains new data, and loads this data from TDR into the transmit shift register (TSR).
2. After loading the data from TDR into TSR, the SCI sets the TDRE bit to 1 and starts transmitting. If the TIE bit (TDR-empty interrupt enable) in SCR is set to 1, the SCI requests a TXI interrupt (TDR-empty interrupt) at this time.

If clock output is selected the SCI outputs eight serial clock pulses, triggered by the clearing of the TDRE bit to 0. If an external clock source is selected, the SCI outputs data in synchronization with the input clock.

Data is output from the TxD pin in order from LSB (bit 0) to MSB (bit 7).

3. The SCI checks the TDRE bit when it outputs the MSB (bit 7). If TDRE is 0, the SCI loads data from TDR into TSR, then begins serial transmission of the next frame. If TDRE is 1, the SCI sets the TEND bit in SSR to 1, transmits the MSB, then holds the output in the MSB state. If the TEIE bit (transmit-end interrupt enable) in SCR is set to 1, a TEI interrupt (TSR-empty interrupt) is requested at this time.
4. After the end of serial transmission, the SCK pin is held at the high level.

Figure 11-14 shows an example of SCI transmit operation.

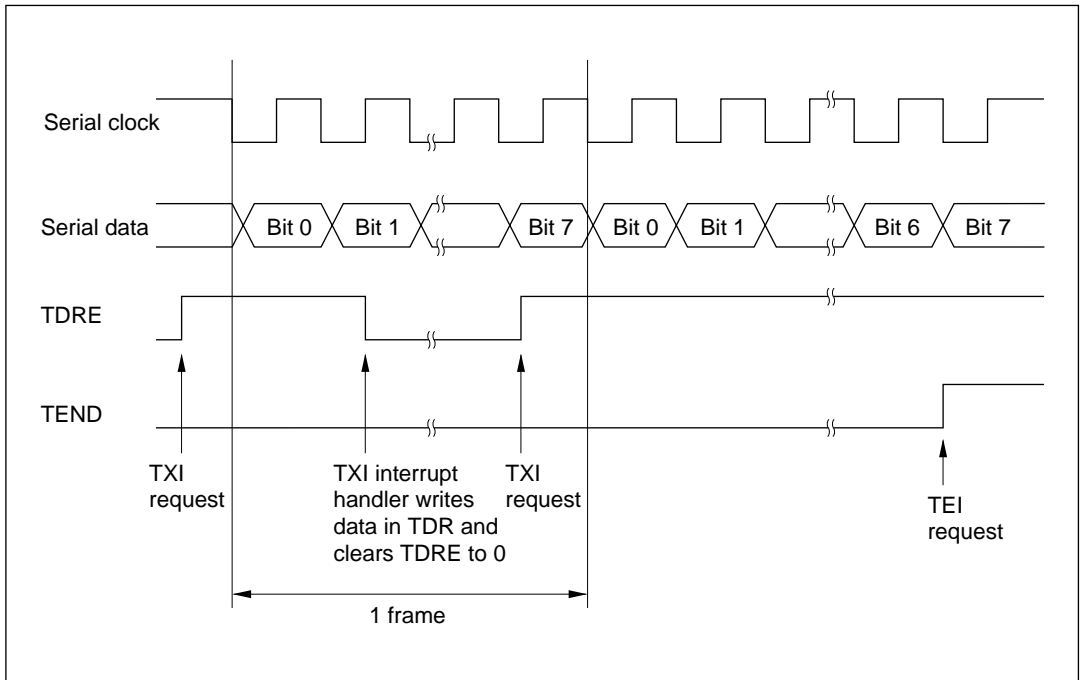

Figure 11-14 Example of SCI Transmit Operation

• **Receiving Serial Data:** Follow the procedure in figure 11-15 for receiving serial data. When switching from asynchronous mode to synchronous mode, be sure to check that PER and FER are cleared to 0. If PER or FER is set to 1 the RDRF bit will not be set and both transmitting and receiving will be disabled.

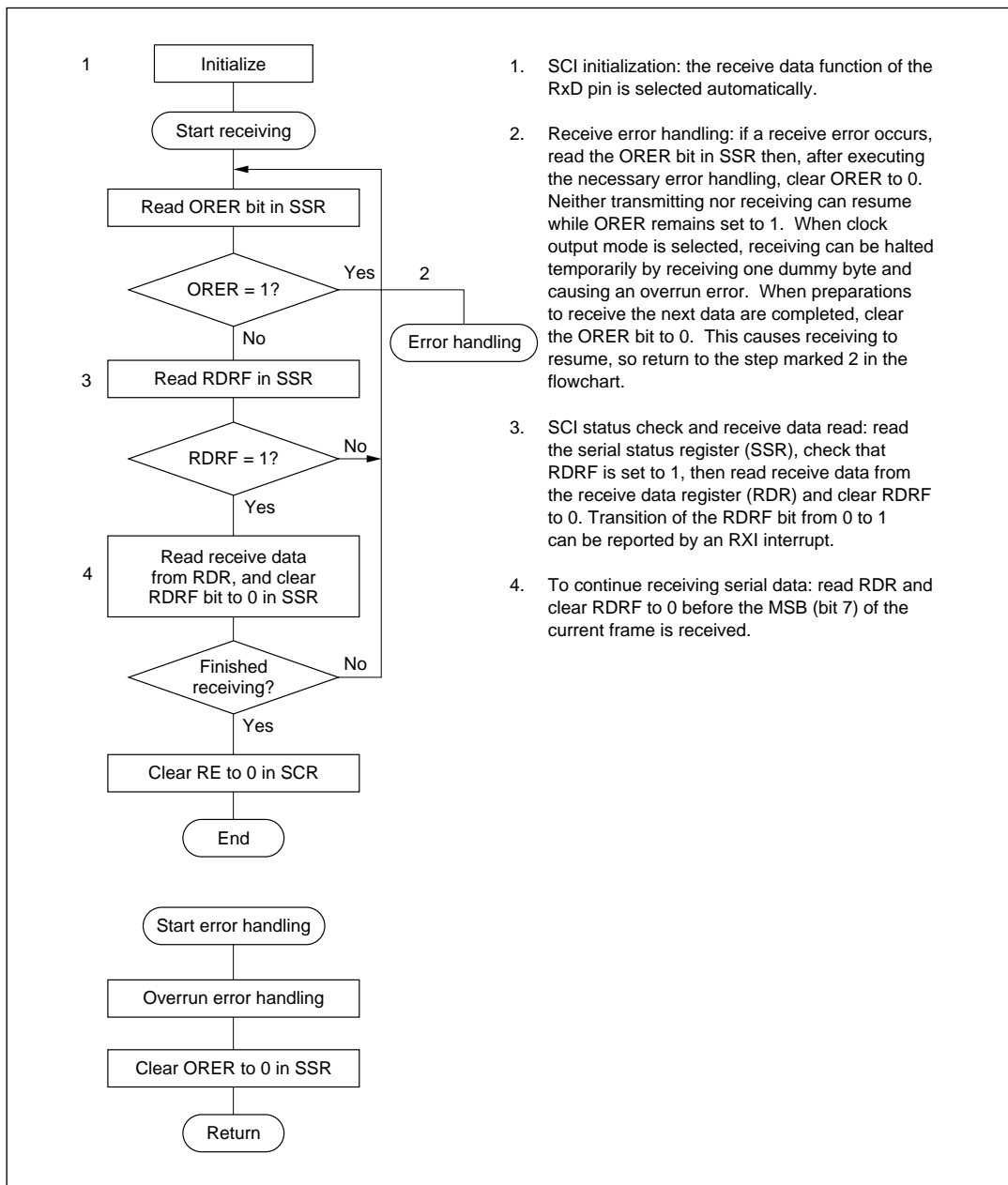

Figure 11-15 Sample Flowchart for Serial Receiving

In receiving, the SCI operates as follows.

1. If an external clock is selected, data is input in synchronization with the input clock. If clock output is selected, as soon as the RE bit is set to 1 the SCI begins outputting the serial clock and inputting data. If clock output is stopped because the ORER bit is set to 1, output of the serial clock and input of data resume as soon as the ORER bit is cleared to 0.
2. Receive data is shifted into RSR in order from LSB to MSB.

After receiving the data, the SCI checks that RDRF is 0 so that receive data can be loaded from RSR into RDR. If this check passes, the SCI sets RDRF to 1 and stores the received data in RDR. If the check does not pass (receive error), the SCI operates as indicated in table 11-8.

Note: Both transmitting and receiving are disabled while a receive error flag is set. The RDRF bit is not set to 1. Be sure to clear the error flag.

3. After setting RDRF to 1, if the RIE bit (receive-end interrupt enable) is set to 1 in SCR, the SCI requests an RXI (receive-end) interrupt. If the ORER bit is set to 1 and the RIE bit in SCR is set to 1, the SCI requests an ERI (receive-error) interrupt.

When clock output mode is selected, clock output stops when the RE bit is cleared to 0 or the ORER bit is set to 1. To prevent clock count errors, it is safest to receive one dummy byte and generate an overrun error.

Figure 11-16 shows an example of SCI receive operation.

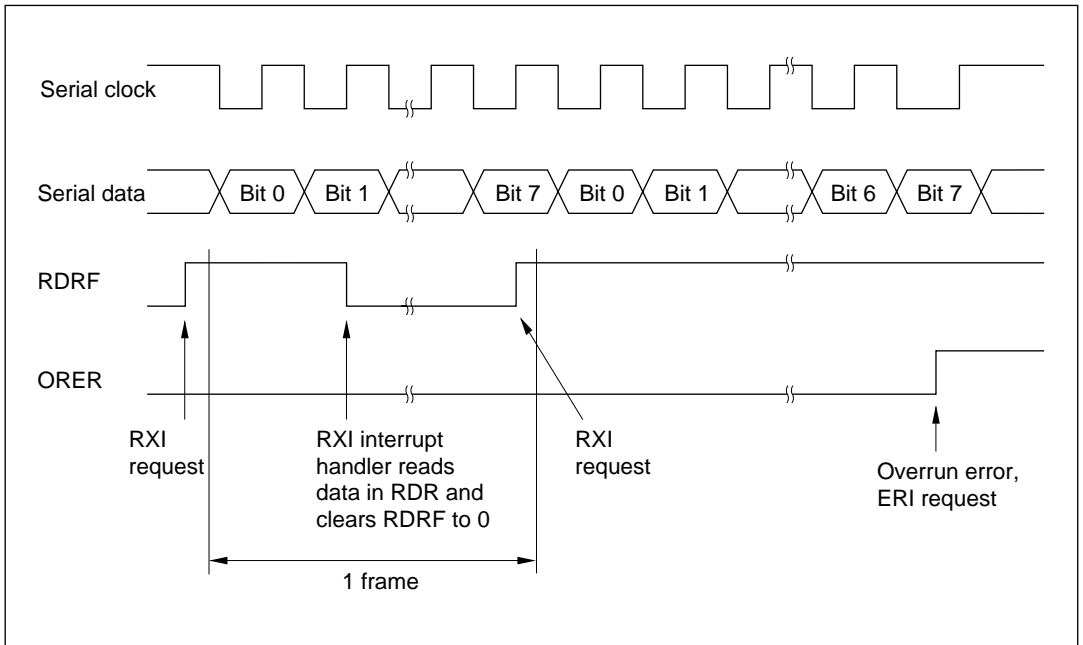

Figure 11-16 Example of SCI Receive Operation

- **Transmitting and Receiving Serial Data Simultaneously:** Follow the procedure in figure 11-17 for transmitting and receiving serial data simultaneously. If clock output mode is selected, output of the serial clock begins simultaneously with serial transmission.

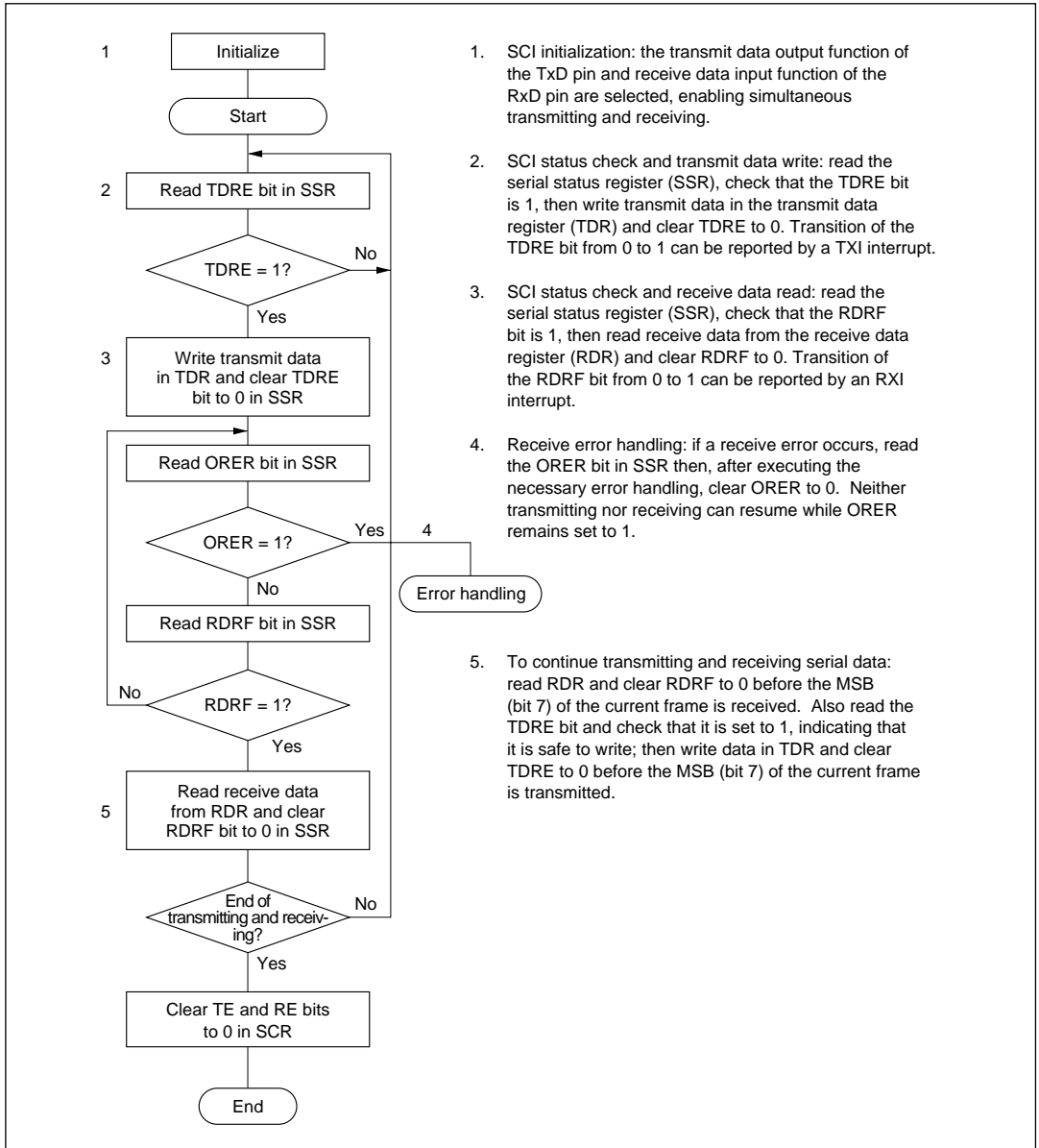

Figure 11-17 Sample Flowchart for Serial Transmitting and Receiving

Note: In switching from transmitting or receiving to simultaneous transmitting and receiving, clear both TE and RE to 0, then set both TE and RE to 1 at the same time.

11.4 Interrupts

The SCI can request four types of interrupts: ERI, RXI, TXI, and TEI. Table 11-9 indicates the source and priority of these interrupts. The interrupt sources can be enabled or disabled by the TIE, RIE, and TEIE bits in the SCR. Independent signals are sent to the interrupt controller for each interrupt source, except that the receive-error interrupt (ERI) is the logical OR of three sources: overrun error, framing error, and parity error.

The TXI interrupt indicates that the next transmit data can be written. The TEI interrupt indicates that the SCI has stopped transmitting data.

Table 11-9 SCI Interrupt Sources

Interrupt	Description	Priority	
ERI	Receive-error interrupt (ORER, FER, or PER)	High	
RxI	Receive-end interrupt (RDRF)		
TxI	TDR-empty interrupt (TDRE)		
TEI	TSR-empty interrupt (TEND)		Low

11.5 Usage Notes

Application programmers should note the following features of the SCI.

(1) TDR Write: The TDRE bit in SSR is simply a flag that indicates that the TDR contents have been transferred to TSR. The TDR contents can be rewritten regardless of the TDRE value. If a new byte is written in TDR while the TDRE bit is 0, before the old TDR contents have been moved into TSR, the old byte will be lost. Software should check that the TDRE bit is set to 1 before writing to TDR.

(2) Multiple Receive Errors: Table 11-10 lists the values of flag bits in the SSR when multiple receive errors occur, and indicates whether the RSR contents are transferred to RDR.

Table 11-10 SSR Bit States and Data Transfer when Multiple Receive Errors Occur

Receive error	SSR Bits				RSR → RDR*2
	RDRF	ORER	FER	PER	
Overflow error	1*1	1	0	0	No
Framing error	0	0	1	0	Yes
Parity error	0	0	0	1	Yes
Overflow and framing errors	1*1	1	1	0	No
Overflow and parity errors	1*1	1	0	1	No
Framing and parity errors	0	0	1	1	Yes
Overflow, framing, and parity errors	1*1	1	1	1	No

Notes: 1. Set to 1 before the overflow error occurs.
 2. Yes: The RSR contents are transferred to RDR.
 No: The RSR contents are not transferred to RDR.

(3) Line Break Detection: When the RxD pin receives a continuous stream of 0's in asynchronous mode (line-break state), a framing error occurs because the SCI detects a 0 stop bit. The value H'00 is transferred from RSR to RDR. Software can detect the line-break state as a framing error accompanied by H'00 data in RDR.

The SCI continues to receive data, so if the FER bit is cleared to 0 another framing error will occur.

(4) Sampling Timing and Receive Margin in Asynchronous Mode: The serial clock used by the SCI in asynchronous mode runs at 16 times the baud rate. The falling edge of the start bit is detected by sampling the RxD input on the falling edge of this clock. After the start bit is detected, each bit of receive data in the frame (including the start bit, parity bit, and stop bit or bits) is sampled on the rising edge of the serial clock pulse at the center of the bit. See figure 11-18.

It follows that the receive margin can be calculated as in equation (1).

When the absolute frequency deviation of the clock signal is 0 and the clock duty cycle is 0.5, data can theoretically be received with distortion up to the margin given by equation (2). This is a theoretical limit, however. In practice, system designers should allow a margin of 20% to 30%.

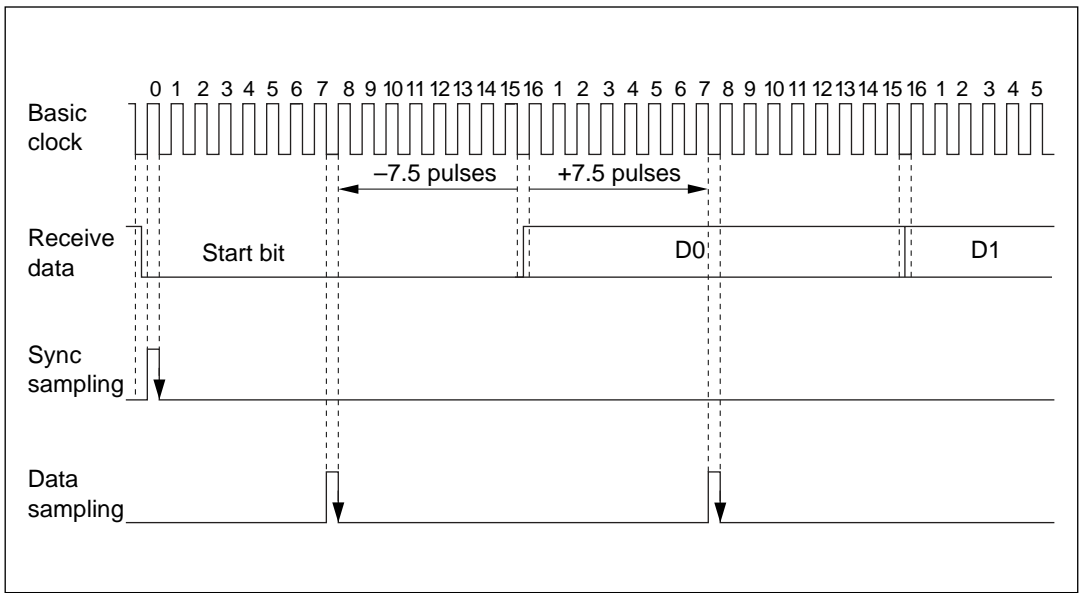

Figure 11-18 Sampling Timing (Asynchronous Mode)

$$M = \{ (0.5 - 1/2N) - (D - 0.5)/N - (L - 0.5)F \} \times 100 [\%] \quad (1)$$

M: Receive margin

N: Ratio of basic clock to baud rate (N=16)

D: Duty factor of clock—ratio of high pulse width to low width (0.5 to 1.0)

L: Frame length (9 to 12)

F: Absolute clock frequency deviation

When D = 0.5 and F = 0

$$M = (0.5 - 1/2 \times 16) \times 100 [\%] = 46.875\% \quad (2)$$

Section 12 A/D Converter

12.1 Overview

The H8/3297 includes a 10-bit successive-approximations A/D converter with a selection of up to eight analog input channels.

12.1.1 Features

A/D converter features are listed below.

- 10-bit resolution
- Eight input channels
- High-speed conversion

Conversion time: minimum 8.4 μ s per channel (with 16-MHz system clock)

- Two conversion modes

Single mode: A/D conversion of one channel

Scan mode: continuous conversion on one to four channels

- Four 16-bit data registers

A/D conversion results are transferred for storage into data registers corresponding to the channels.

- Sample-and-hold function
- A/D conversion can be externally triggered
- A/D interrupt requested at end of conversion

At the end of A/D conversion, an A/D end interrupt (ADI) can be requested.

12.1.2 Block Diagram

Figure 12-1 shows a block diagram of the A/D converter.

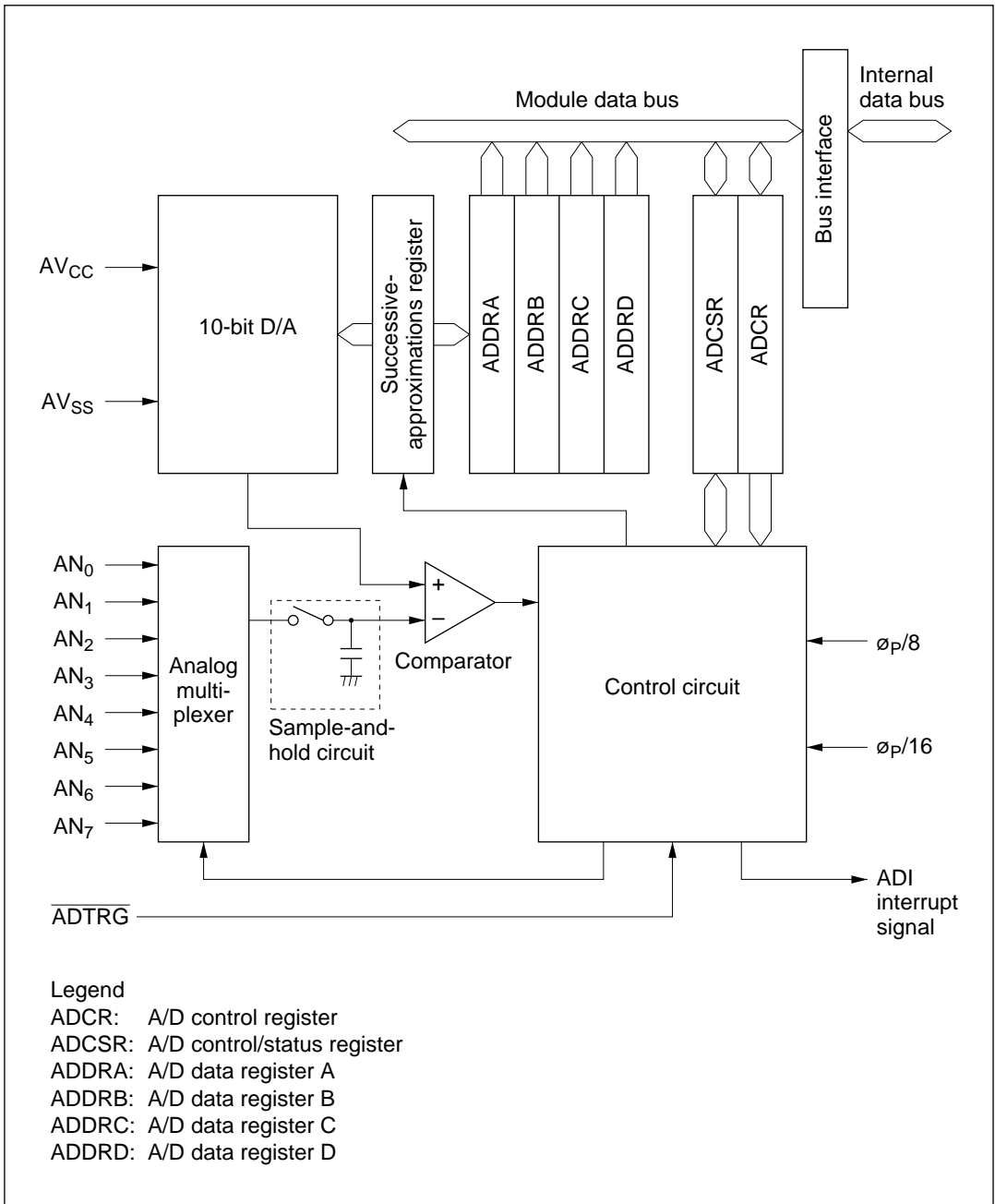

Figure 12-1 A/D Converter Block Diagram

12.1.3 Input Pins

Table 12-1 lists the A/D converter's input pins. The eight analog input pins are divided into two groups: group 0 (AN₀ to AN₃), and group 1 (AN₄ to AN₇). AV_{CC} and AV_{SS} are the power supply for the analog circuits in the A/D converter.

Table 12-1 A/D Converter Pins

Pin Name	Abbreviation	I/O	Function
Analog power supply pin	AV _{CC}	Input	Analog power supply
Analog ground pin	AV _{SS}	Input	Analog ground and reference voltage
Analog input pin 0	AN ₀	Input	Group 0 analog inputs
Analog input pin 1	AN ₁	Input	
Analog input pin 2	AN ₂	Input	
Analog input pin 3	AN ₃	Input	
Analog input pin 4	AN ₄	Input	Group 1 analog inputs
Analog input pin 5	AN ₅	Input	
Analog input pin 6	AN ₆	Input	
Analog input pin 7	AN ₇	Input	
A/D external trigger input pin	$\overline{\text{ADTRG}}$	Input	External trigger input for starting A/D conversion

12.1.4 Register Configuration

Table 12-2 summarizes the A/D converter's registers.

Table 12-2 A/D Converter Registers

Name	Abbreviation	R/W	Initial Value	Address
A/D data register A (high)	ADDRAH	R	H'00	H'FFE0
A/D data register A (low)	ADDRAL	R	H'00	H'FFE1
A/D data register B (high)	ADDRBH	R	H'00	H'FFE2
A/D data register B (low)	ADDRBL	R	H'00	H'FFE3
A/D data register C (high)	ADDRCH	R	H'00	H'FFE4
A/D data register C (low)	ADDRCL	R	H'00	H'FFE5
A/D data register D (high)	ADDRDH	R	H'00	H'FFE6
A/D data register D (low)	ADDRDL	R	H'00	H'FFE7
A/D control/status register	ADCSR	R/W*	H'00	H'FFE8
A/D control register	ADCR	R/W	H'7F	H'FFE9

Note: * Only 0 can be written in bit 7, to clear the flag.

12.2 Register Descriptions

12.2.1 A/D Data Registers A to D (ADDRA to ADDR D)

Bit	15	14	13	12	11	10	9	8	7	6	5	4	3	2	1	0
	AD9	AD8	AD7	AD6	AD5	AD4	AD3	AD2	AD1	AD0	—	—	—	—	—	—
Initial value	0	0	0	0	0	0	0	0	0	0	0	0	0	0	0	0
Read/Write	R	R	R	R	R	R	R	R	R	R	R	R	R	R	R	R

Bits 15 to 6—A/D Conversion Data (AD9 to AD0): 10-bit data giving an A/D conversion result.

Bits 5 to 0—Reserved: These bits cannot be modified and are always read as 0.

The four A/D data registers (ADDRA to ADDR D) are 16-bit read-only registers that store the results of A/D conversion.

An A/D conversion produces 10-bit data, which is transferred for storage into the A/D data register corresponding to the selected channel. The upper 8 bits of the result are stored in the upper byte of the A/D data register. The lower 2 bits are stored in the lower byte. Bits 5 to 0 of an A/D data register are reserved bits that always read 0. Table 12-3 indicates the pairings of analog input channels and A/D data registers.

The CPU can always read and write the A/D data registers. The upper byte can be read directly, but the lower byte is read through a temporary register (TEMP). For details see section 12.3, CPU Interface.

The A/D data registers are initialized to H'0000 by a reset and in standby mode.

Table 12-3 Analog Input Channels and A/D Data Registers

Analog Input Channel		A/D Data Register
Group 0	Group 1	
AN ₀	AN ₄	ADDRA
AN ₁	AN ₅	ADDRB
AN ₂	AN ₆	ADDRC
AN ₃	AN ₇	ADDRD

12.2.2 A/D Control/Status Register (ADCSR)

Bit	7	6	5	4	3	2	1	0
	ADF	ADIE	ADST	SCAN	CKS	CH2	CH1	CH0
Initial value	0	0	0	0	0	0	0	0
Read/Write	R/(W)*	R/W	R/W	R/W	R/W	R/W	R/W	R/W

Note: * Only 0 can be written, to clear the flag.

ADCSR is an 8-bit readable/writable register that selects the mode and controls the A/D converter. ADCSR is initialized to H'00 by a reset and in standby mode.

Bit 7—A/D End Flag (ADF): Indicates the end of A/D conversion.

Bit 7 ADF	Description	
0	[Clearing condition] Cleared by reading ADF while ADF = 1, then writing 0 in ADF	(Initial value)
1	[Setting conditions] 1. Single mode: A/D conversion ends 2. Scan mode: A/D conversion ends in all selected channels	

Bit 6—A/D Interrupt Enable (ADIE): Enables or disables the interrupt (ADI) requested at the end of A/D conversion.

Bit 6 ADIE	Description	
0	A/D end interrupt request (ADI) is disabled	(Initial value)
1	A/D end interrupt request (ADI) is enabled	

Bit 5—A/D Start (ADST): Starts or stops A/D conversion. The ADST bit remains set to 1 during A/D conversion. It can also be set to 1 by external trigger input at the ADTRG pin.

Bit 5 ADST	Description	
0	A/D conversion is stopped	(Initial value)
1	1. Single mode: A/D conversion starts; ADST is automatically cleared to 0 when conversion ends 2. Scan mode: A/D conversion starts and continues, cycling among the selected channels, until ADST is cleared to 0 by software, by a reset, or by a transition to standby mode	

Bit 4—Scan Mode (SCAN): Selects single mode or scan mode. For further information on operation in these modes, see section 12.4, Operation. Clear the ADST bit to 0 before switching the conversion mode.

Bit 4

SCAN	Description	
0	Single mode	(Initial value)
1	Scan mode	

Bit 3—Clock Select (CKS): Selects the A/D conversion time. When $\phi_P = \phi/2$, the conversion time doubles. Clear the ADST bit to 0 before switching the conversion time.

Bit 3

CKS	Description	
0	Conversion time = 266 states (maximum) (when $\phi_P = \phi$)	(Initial value)
1	Conversion time = 134 states (maximum) (when $\phi_P = \phi$)	

Bits 2 to 0—Channel Select 2 to 0 (CH2 to CH0): These bits and the SCAN bit select the analog input channels. Clear the ADST bit to 0 before changing the channel selection.

Group Selection	Channel Selection		Description	
	CH1	CH0	Single Mode	Scan Mode
0	0	0	AN ₀ (initial value)	AN ₀
	0	1	AN ₁	AN ₀ , AN ₁
	1	0	AN ₂	AN ₀ to AN ₂
	1	1	AN ₃	AN ₀ to AN ₃
1	0	0	AN ₄	AN ₄
	0	1	AN ₅	AN ₄ , AN ₅
	1	0	AN ₆	AN ₄ to AN ₆
	1	1	AN ₇	AN ₄ to AN ₇

12.2.3 A/D Control Register (ADCR)

Bit	7	6	5	4	3	2	1	0
	TRGE	—	—	—	—	—	—	—
Initial value	0	1	1	1	1	1	1	1
Read/Write	R/W	—	—	—	—	—	—	—

ADCR is an 8-bit readable/writable register that enables or disables external triggering of A/D conversion. ADCR is initialized to H'7F by a reset and in standby mode.

Bit 7—Trigger Enable (TRGE): Enables or disables external triggering of A/D conversion.

Bit 7

TRGE	Description
0	A/D conversion cannot be externally triggered (Initial value)
1	Enables start of A/D conversion by the external trigger signal (ADTRG) (A/D conversion can be started either by an external trigger or by software.)

Bits 6 to 0—Reserved: These bits cannot be modified, and are always read as 1.

12.3 CPU Interface

ADDRA to ADDRD are 16-bit registers, but they are connected to the CPU by an 8-bit data bus. Therefore, although the upper byte can be accessed directly by the CPU, the lower byte is read through an 8-bit temporary register (TEMP).

An A/D data register is read as follows. When the upper byte is read, the upper-byte value is transferred directly to the CPU and the lower-byte value is transferred into TEMP. Next, when the lower byte is read, the TEMP contents are transferred to the CPU.

When reading an A/D data register, always read the upper byte before the lower byte. It is possible to read only the upper byte, but if only the lower byte is read, incorrect data may be obtained.

Figure 12-2 shows the data flow for access to an A/D data register.

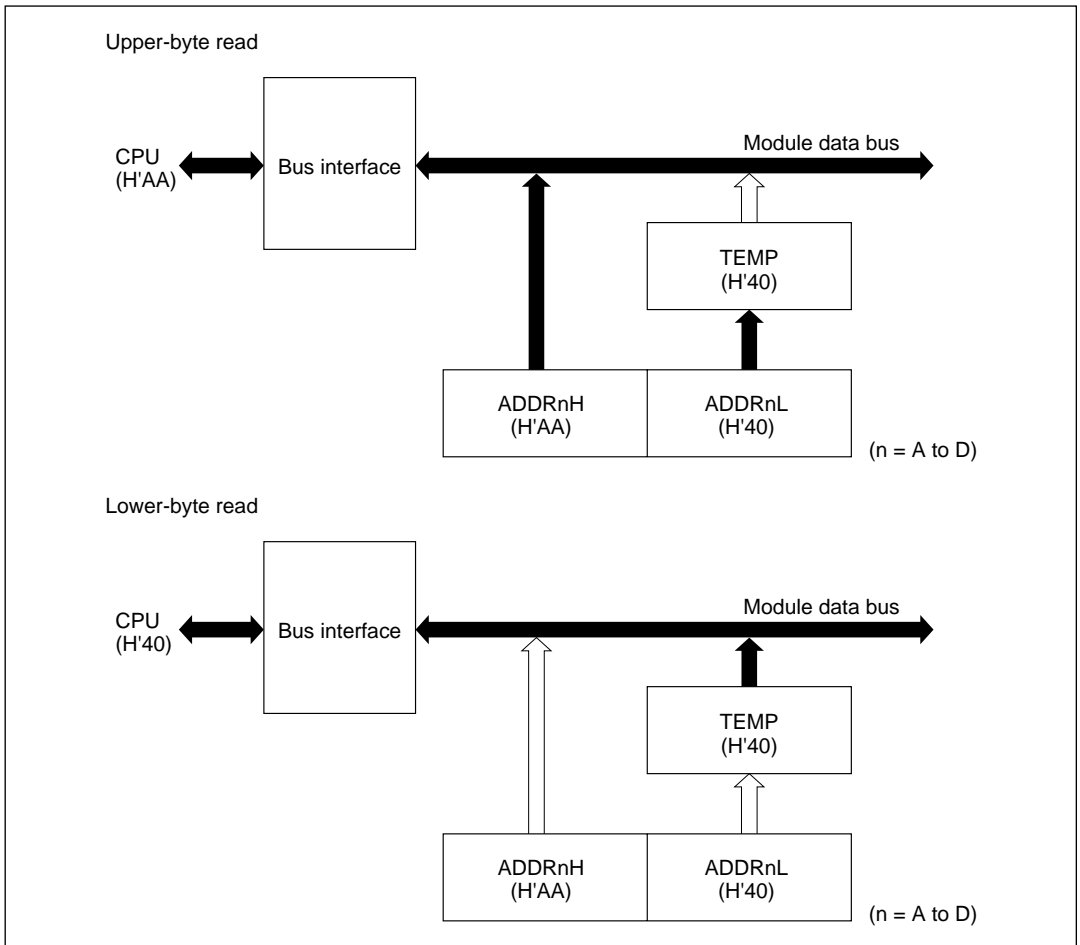

Figure 12-2 A/D Data Register Access Operation (Reading H'AA40)

12.4 Operation

The A/D converter operates by successive approximations with 10-bit resolution. It has two operating modes: single mode and scan mode.

12.4.1 Single Mode (SCAN = 0)

Single mode should be selected when only one A/D conversion on one channel is required. A/D conversion starts when the ADST bit is set to 1 by software, or by external trigger input. The ADST bit remains set to 1 during A/D conversion and is automatically cleared to 0 when conversion ends.

When conversion ends the ADF bit is set to 1. If the ADIE bit is also set to 1, an ADI interrupt is requested at this time. To clear the ADF flag to 0, first read ADCSR, then write 0 in ADF.

When the mode or analog input channel must be switched during analog conversion, to prevent incorrect operation, first clear the ADST bit to 0 in ADCSR to halt A/D conversion. After making the necessary changes, set the ADST bit to 1 to start A/D conversion again. The ADST bit can be set at the same time as the mode or channel is changed.

Typical operations when channel 1 (AN₁) is selected in single mode are described next. Figure 12-3 shows a timing diagram for this example.

1. Single mode is selected (SCAN = 0), input channel AN₁ is selected (CH2 = CH1 = 0, CH0 = 1), the A/D interrupt is enabled (ADIE = 1), and A/D conversion is started (ADST = 1).
2. When A/D conversion is completed, the result is transferred into ADDR_B. At the same time the ADF flag is set to 1, the ADST bit is cleared to 0, and the A/D converter becomes idle.
3. Since ADF = 1 and ADIE = 1, an ADI interrupt is requested.
4. The A/D interrupt handling routine starts.
5. The routine reads ADCSR, then writes 0 in the ADF flag.
6. The routine reads and processes the conversion result (ADDR_B).
7. Execution of the A/D interrupt handling routine ends.

After that, if the ADST bit is set to 1, A/D conversion starts again and steps 2 to 7 are repeated.

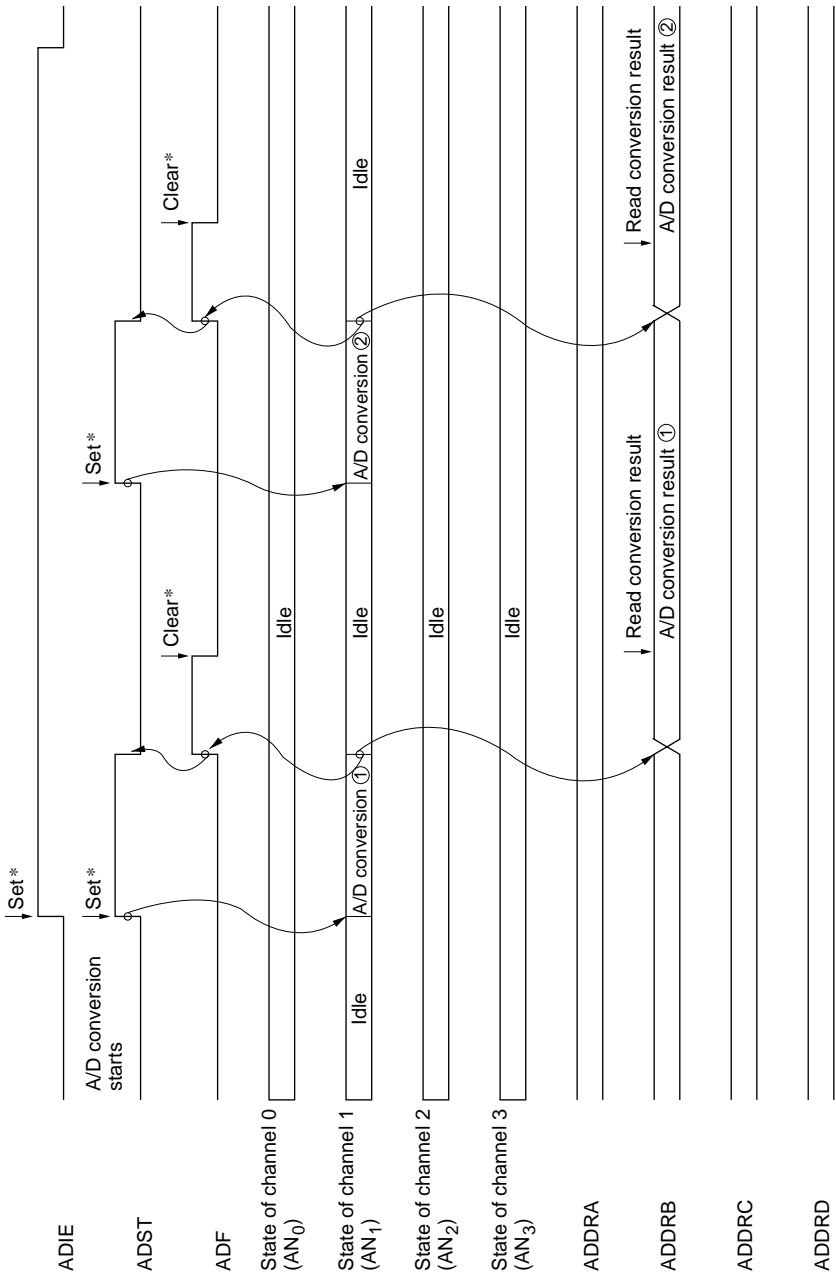

Note: *Vertical arrows (↓) indicate instructions executed by software.

Figure 12-3 Example of A/D Converter Operation (Single Mode, Channel 1 Selected)

12.4.2 Scan Mode (SCAN = 1)

Scan mode is useful for monitoring analog inputs in a group of one or more channels. When the ADST bit is set to 1 by software or external trigger input, A/D conversion starts on the first channel in the group (AN_0 when $CH2 = 0$, AN_4 when $CH2 = 1$). When two or more channels are selected, after conversion of the first channel ends, conversion of the second channel (AN_1 or AN_5) starts immediately. A/D conversion continues cyclically on the selected channels until the ADST bit is cleared to 0. The conversion results are transferred for storage into the A/D data registers corresponding to the channels.

When the mode or analog input channel selection must be changed during analog conversion, to prevent incorrect operation, first clear the ADST bit to 0 in ADCSR to halt A/D conversion. After making the necessary changes, set the ADST bit to 1. A/D conversion will start again from the first channel in the group. The ADST bit can be set at the same time as the mode or channel selection is changed.

Typical operations when three channels in group 0 (AN_0 to AN_2) are selected in scan mode are described next. Figure 12-4 shows a timing diagram for this example.

1. Scan mode is selected ($SCAN = 1$), scan group 0 is selected ($CH2 = 0$), analog input channels AN_0 to AN_2 are selected ($CH1 = 1$, $CH0 = 0$), and A/D conversion is started ($ADST = 1$).
2. When A/D conversion of the first channel (AN_0) is completed, the result is transferred into ADDRA. Next, conversion of the second channel (AN_1) starts automatically.
3. Conversion proceeds in the same way through the third channel (AN_2).
4. When conversion of all selected channels (AN_0 to AN_2) is completed, the ADF flag is set to 1 and conversion of the first channel (AN_0) starts again. If the ADIE bit is set to 1, an ADI interrupt is requested at this time.
5. Steps 2 to 4 are repeated as long as the ADST bit remains set to 1. When the ADST bit is cleared to 0, A/D conversion stops. After that, if the ADST bit is set to 1, A/D conversion starts again from the first channel (AN_0).

12.4.3 Input Sampling and A/D Conversion Time

The A/D converter has a built-in sample-and-hold circuit. The A/D converter samples the analog input at a time t_D after the ADST bit is set to 1, then starts conversion. Figure 12-5 shows the A/D conversion timing. Table 12-4 indicates the A/D conversion time.

As indicated in figure 12-5, the A/D conversion time includes t_D and the input sampling time. The length of t_D varies depending on the timing of the write access to ADCSR. The total conversion time therefore varies within the ranges indicated in table 12-4.

In scan mode, the values given in table 12-4 apply to the first conversion. In the second and subsequent conversions the conversion time is fixed at 256 states when $CKS = 0$ or 128 states when $CKS = 1$ (when $\phi_P = \emptyset$).

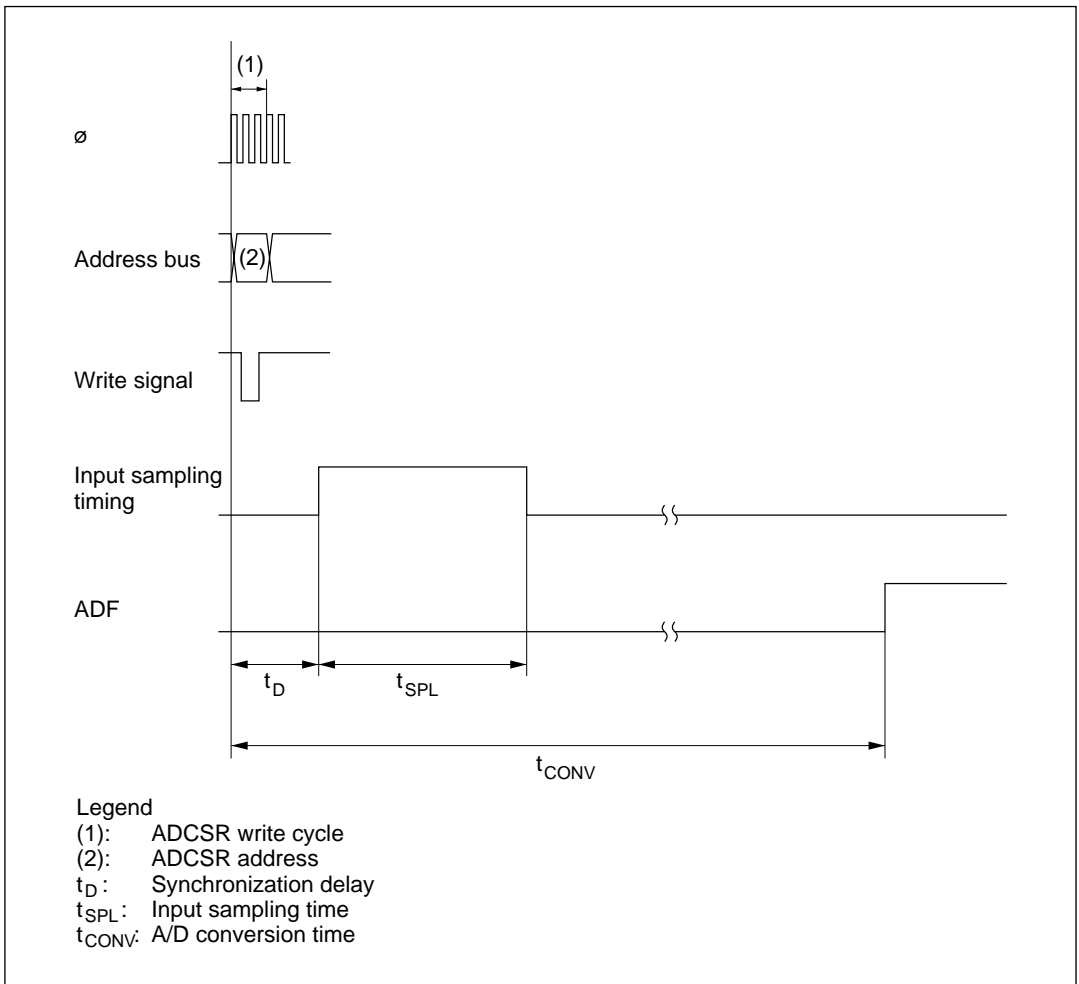

Figure 12-5 A/D Conversion Timing

Table 12-4 A/D Conversion Time (Single Mode)

	Symbol	CKS = 0			CKS = 1		
		Min	Typ	Max	Min	Typ	Max
Synchronization delay	t_D	10	—	17	6	—	9
Input sampling time*	t_{SPL}	—	80	—	—	40	—
A/D conversion time*	t_{CONV}	259	—	266	131	—	134

Note: Values in the table are numbers of states.

* Values for when $\phi_P = \phi$. When $\phi_P = \phi/2$, values are double those given in the table.

12.4.4 External Trigger Input Timing

A/D conversion can be externally triggered. When the TRGE bit is set to 1 in ADCR, external trigger input is enabled at the \overline{ADTRG} pin. A high-to-low transition at the \overline{ADTRG} pin sets the ADST bit to 1 in ADCSR, starting A/D conversion. Other operations, in both single and scan modes, are the same as if the ADST bit had been set to 1 by software. Figure 12-6 shows the timing.

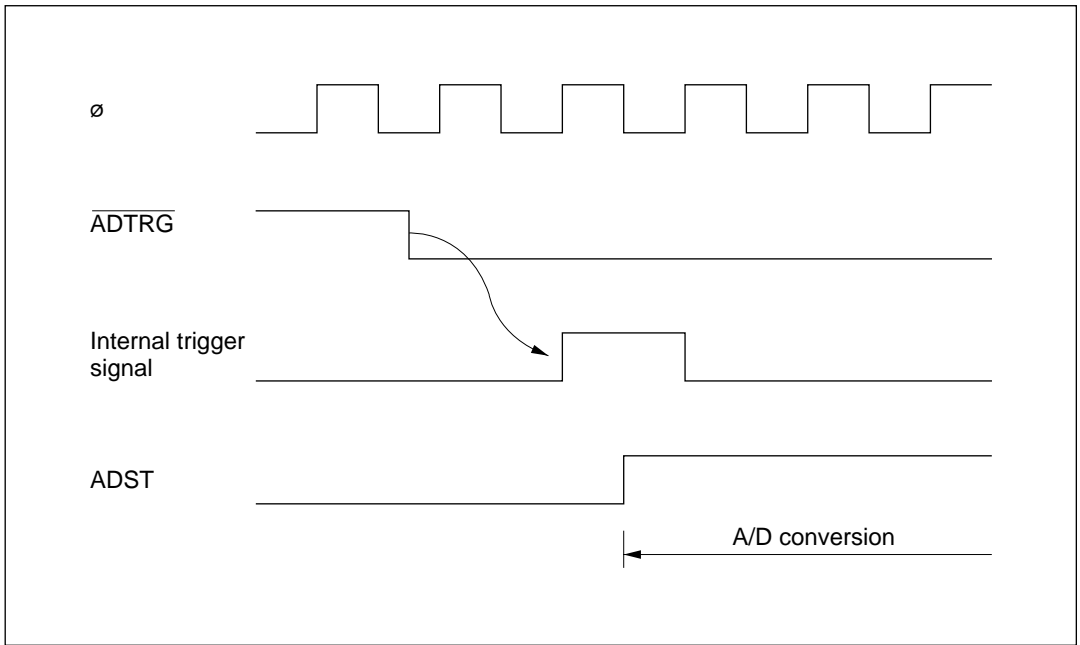

Figure 12-6 External Trigger Input Timing

12.5 Interrupts

The A/D converter generates an interrupt (ADI) at the end of A/D conversion. The ADI interrupt request can be enabled or disabled by the ADIE bit in ADCSR.

12.6 Usage Notes

The following points should be noted when using the A/D converter.

1. Analog input voltage range

Ensure that the voltage applied to analog input pin AN_n (where $n = 0$ to 7) during A/D conversion is in the range $AV_{SS} \leq AN_n \leq AV_{CC}$.

2. AV_{CC} and AV_{SS} input voltages

For the AV_{CC} input voltage, set $AV_{SS} = V_{SS}$. When the A/D converter is not used, set $AV_{CC} = V_{CC}$ and $AV_{SS} = V_{SS}$.

Section 13 RAM

13.1 Overview

The H8/3297 and H8/3296 have 2 kbytes of on-chip static RAM. The H8/3294 has 1 kbyte. The H8/3292 has 512 bytes. The RAM is connected to the CPU by a 16-bit data bus. Both byte and word access to the on-chip RAM are performed in two states, enabling rapid data transfer and instruction execution.

The on-chip RAM is assigned to addresses H'F780 to H'FF7F in the address space of the H8/3297 and H8/3296, addresses H'FB80 to H'FF7F in the address space of the H8/3294, and addresses H'FD80 to H'FF7F in the address space of the H8/3292. The RAME bit in the system control register (SYSCR) can enable or disable the on-chip RAM.

13.1.1 Block Diagram

Figure 13-1 is a block diagram of the on-chip RAM.

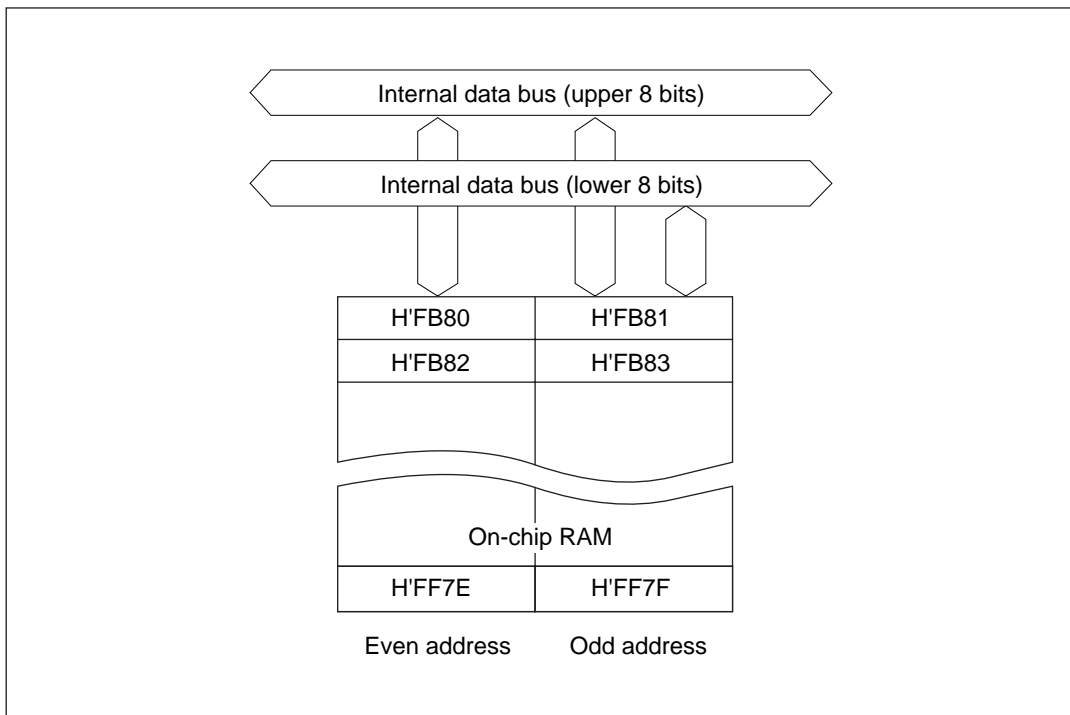

Figure 13-1 Block Diagram of On-Chip RAM (H8/3297)

13.1.2 RAM Enable Bit (RAME) in System Control Register (SYSCR)

Bit	7	6	5	4	3	2	1	0
	SSBY	STS2	STS1	STS0	XRST	NMIEG	—	RAME
Initial value	0	0	0	0	1	0	1	1
Read/Write	R/W	R/W	R/W	R/W	R	R/W	—	R/W

The on-chip RAM is enabled or disabled by the RAME bit in SYSCR. See section 3.2, System Control Register, for the other SYSCR bits.

Bit 0—RAM Enable (RAME): This bit enables or disables the on-chip RAM. The RAME bit is initialized to 1 on the rising edge of the RES signal. The RAME bit is not initialized in software standby mode.

Bit 0

RAME	Description
0	On-chip RAM is disabled.
1	On-chip RAM is enabled. (Initial value)

13.2 Operation

13.2.1 Expanded Modes (Modes 1 and 2)

If the RAME bit is set to 1, accesses to addresses H'F780 to H'FF7F in the H8/3297 and H8/3296, addresses H'FB80 to H'FF7F in the H8/3294, and addresses H'FD80 to H'FF7F in the H8/3292 are directed to the on-chip RAM. If the RAME bit is cleared to 0, accesses to these addresses are directed to the external data bus.

13.2.2 Single-Chip Mode (Mode 3)

If the RAME bit is set to 1, accesses to addresses H'F780 to H'FF7F in the H8/3297 and H8/3296, addresses H'FB80 to H'FF7F in the H8/3294, and addresses H'FD80 to H'FF7F in the H8/3292 are directed to the on-chip RAM.

If the RAME bit is cleared to 0, the on-chip RAM data cannot be accessed. Attempted write access has no effect. Attempted read access always results in H'FF data being read.

Note: RAM initial values are undefined. Therefore initialization must be carried out before use.

Section 14 ROM

14.1 Overview

The size of the on-chip ROM (mask ROM, or PROM) is 60 kbytes in the H8/3297, 48 kbytes in the H8/3296, 32 kbytes in the H8/3294, and 16kbytes in the H8/3292. The on-chip ROM is connected to the CPU via a 16-bit data bus. Both byte data and word data are accessed in two states, enabling rapid data transfer.

The on-chip ROM is enabled or disabled depending on the inputs at the mode pins (MD_1 and MD_0). See table 14-1.

Table 14-1 On-Chip ROM Usage in Each MCU Mode

Mode	Mode Pins		On-chip ROM
	MD_1	MD_0	
Mode 1 (expanded mode)	0	1	Disabled (external addresses)
Mode 2 (expanded mode)	1	0	Enabled
Mode 3 (single-chip mode)	1	1	Enabled

The PROM versions (H8/3297 ZTAT and H8/3294 ZTAT) can be set to PROM mode and programmed with a general-purpose PROM programmer. In the H8/3297, the accessible ROM addresses are H'0000 to H'EF7F (61,312 bytes) in mode 2, and H'0000 to H'F77F (63,360 bytes) in mode 3. For details, see section 3, MCU Operating Modes and Address Space.

14.1.1 Block Diagram

Figure 14-1 is a block diagram of the on-chip ROM.

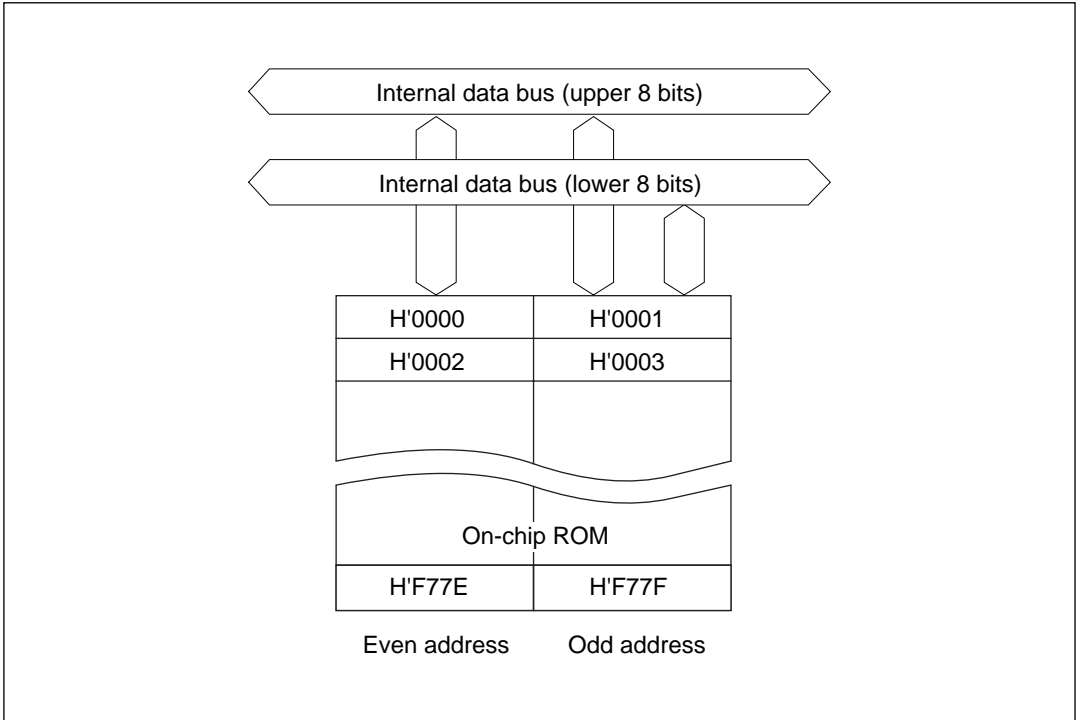

Figure 14-1 Block Diagram of On-Chip ROM (H8/3297 Single-Chip Mode)

14.2 PROM Mode (H8/3297, H8/3294)

14.2.1 PROM Mode Setup

In PROM mode the PROM versions of the H8/3297 and H8/3294 suspend, the usual microcomputer functions to allow the on-chip PROM to be programmed. The programming method is the same as for the HN27C101.

To select PROM mode, apply the signal inputs listed in table 14-2.

Table 14-2 Selection of PROM Mode

Pin	Input
Mode pin MD ₁	Low
Mode pin MD ₀	Low
$\overline{\text{STBY}}$ pin	Low
Pins P6 ₃ and P6 ₄	High

14.2.2 Socket Adapter Pin Assignments and Memory Map

The H8/3297 and H8/3294 can be programmed with a general-purpose PROM programmer by using a socket adapter to change the pin-out to 32 pins. See table 14-3. The same socket adapter can be used for both the H8/3297 and H8/3294. Figure 14-2 shows the socket adapter pin assignments.

Table 14-3 Socket Adapter

Package	Socket Adapter
64-pin QFP	HS3297ESHS1H
80-pin TQFP	HS3297ESNS1H
64-pin windowed shrink DIP	HS3297ESSS1H
64-pin shrink DIP	HS3297ESSS1H

The PROM size is 60 kbytes for the H8/3297 and 32 kbytes for the H8/3294. Figures 14-3 and 14-4 show memory maps of the H8/3297 and H8/3294 in PROM mode. H'FF data should be specified for unused address areas in the on-chip PROM.

When programming with a PROM programmer, limit the program address range to H'0000 to H'F77F for the H8/3297 and H'0000 to H'7FFF for the H8/3294. Specify H'FF data for addresses H'F780 and above (H8/3297) or H'8000 and above (H8/3294). If these addresses are programmed by mistake, it may become impossible to program or verify the PROM data. The same problem may occur if an attempt is made to program the chip in page programming mode. With a windowed package, it is possible to erase the data and reprogram, but this cannot be done with a plastic package, so particular care is required.

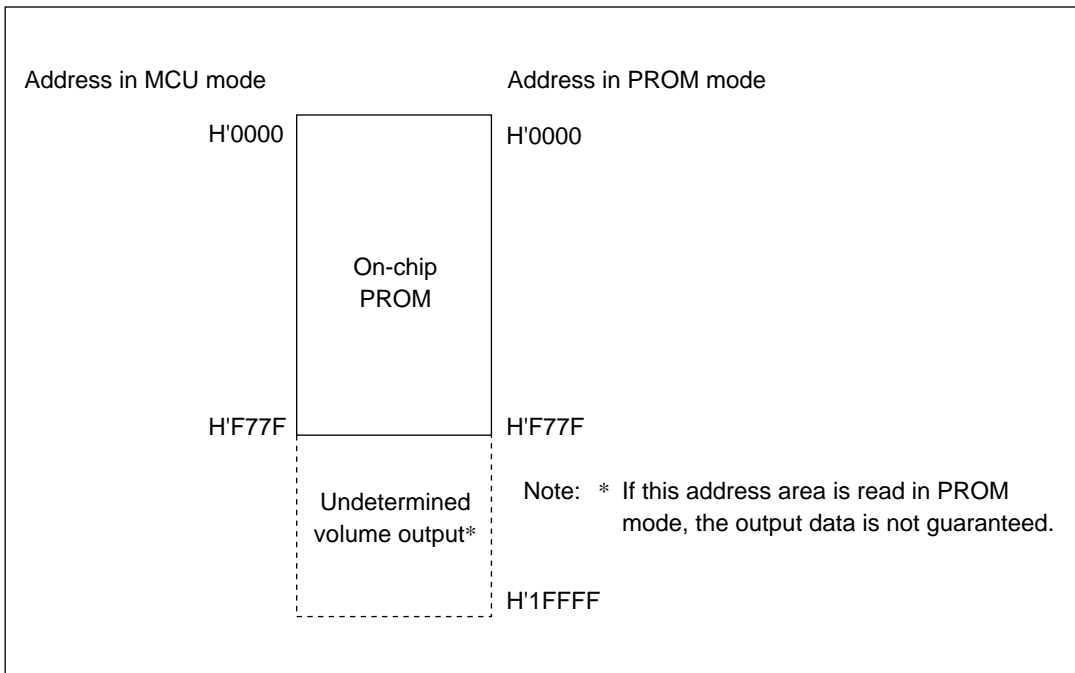

Figure 14-3 H8/3297 Memory Map in PROM Mode

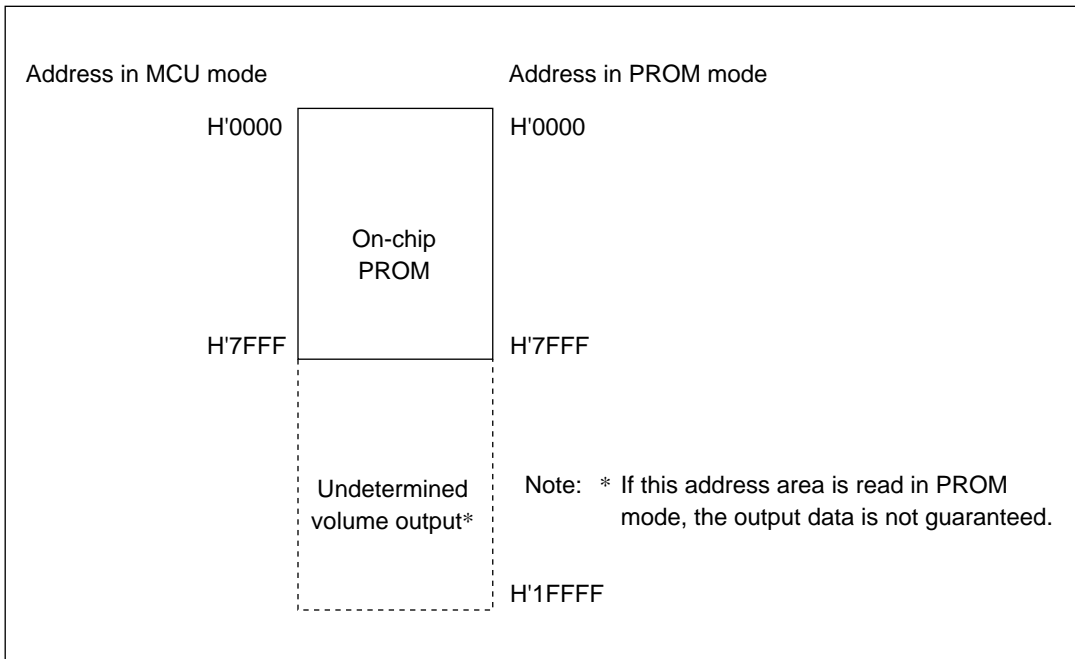

Figure 14-4 H8/3294 Memory Map in PROM Mode

14.3 PROM Programming

The write, verify, and other sub-modes of the PROM mode are selected as shown in table 14-4.

Table 14-4 Selection of Sub-Modes in PROM Mode

Sub-Mode	$\overline{\text{CE}}$	$\overline{\text{OE}}$	$\overline{\text{PGM}}$	V_{PP}	V_{CC}	EO_7 to EO_0	EA_{16} to EA_0
Write	Low	High	Low	V_{PP}	V_{CC}	Data input	Address input
Verify	Low	Low	High	V_{PP}	V_{CC}	Data output	Address input
Programming inhibited	Low	Low	Low	V_{PP}	V_{CC}	High impedance	Address input
	Low	High	High				
	High	Low	Low				
	High	High	High				

The H8/3297 and H8/3294 PROM have the same standard read/write specifications as the HN27C101 EPROM. Page programming is not supported, however, so do not select page programming mode. PROM programmers that provide only page programming cannot be used. When selecting a PROM programmer, check that it supports a byte-at-a-time high-speed programming mode. Be sure to set the address range to H'0000 to H'F77F for the H8/3297, and to H'0000 to H'7FFF for the H8/3294.

14.3.1 Programming and Verifying

An efficient, high-speed programming procedure can be used to program and verify PROM data. This procedure programs data quickly without subjecting the chip to voltage stress and without sacrificing data reliability. It leaves the data H'FF in unused addresses.

Figure 14-5 shows the basic high-speed programming flowchart.

Tables 14-5 and 14-6 list the electrical characteristics of the chip in PROM mode. Figure 14-6 shows a program/verify timing chart.

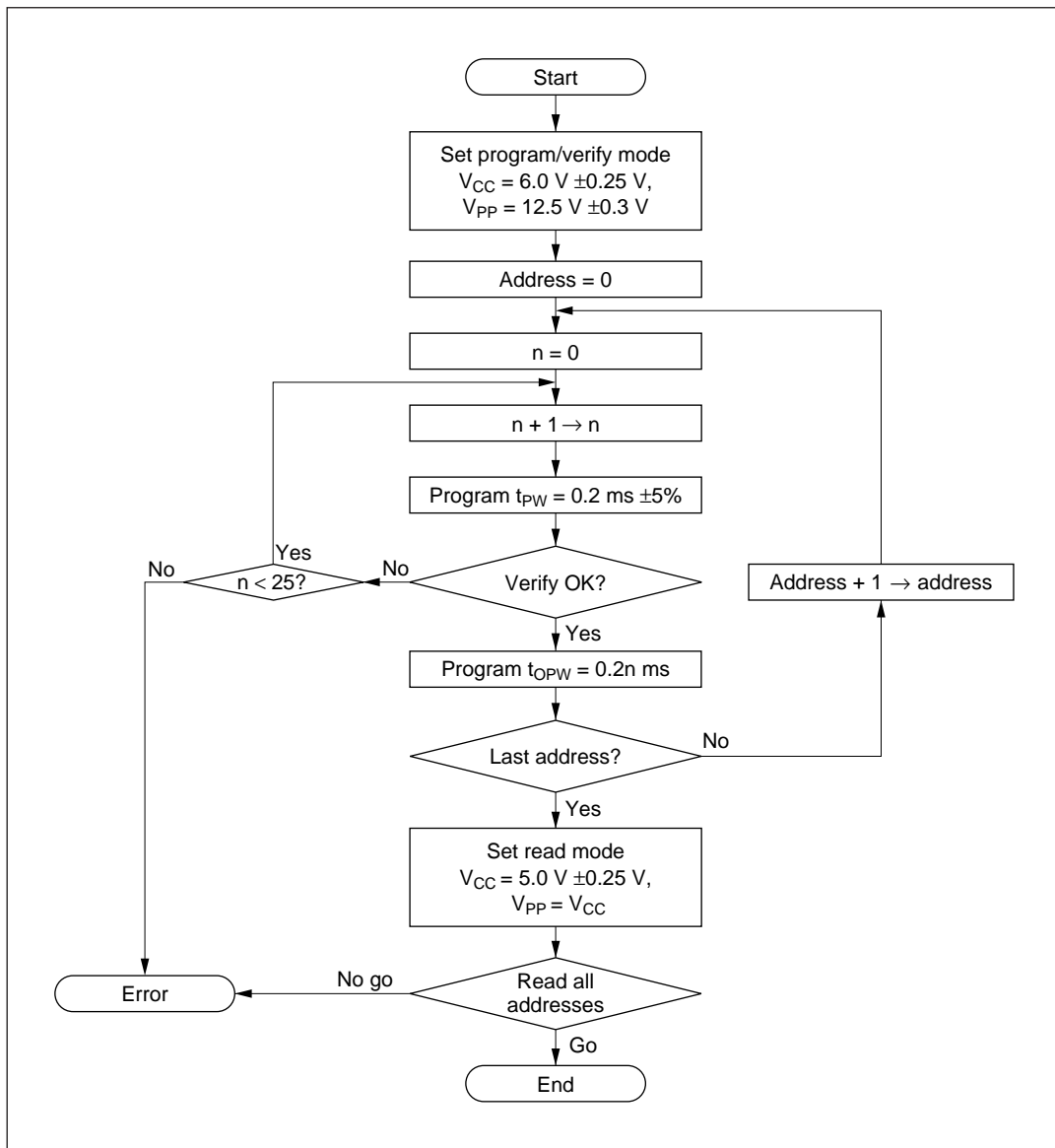

Figure 14-5 High-Speed Programming Flowchart

Table 14-5 DC Characteristics(when $V_{CC} = 6.0 \text{ V} \pm 0.25 \text{ V}$, $V_{PP} = 12.5 \text{ V} \pm 0.3 \text{ V}$, $V_{SS} = 0 \text{ V}$, $T_a = 25^\circ\text{C} \pm 5^\circ\text{C}$)

Item		Symbol	Min	Typ	Max	Unit	Test Conditions
Input high voltage	$EO_7 - EO_0$, $A_{16} - A_0$, \overline{OE} , \overline{CE} , \overline{PGM}	V_{IH}	2.4	—	$V_{CC} + 0.3$	V	
Input low voltage	$EO_7 - EO_0$, $A_{16} - A_0$, \overline{OE} , \overline{CE} , \overline{PGM}	V_{IL}	-0.3	—	0.8	V	
Output high voltage	$EO_7 - EO_0$	V_{OH}	2.4	—	—	V	$I_{OH} = -200 \mu\text{A}$
Output low voltage	$EO_7 - EO_0$	V_{OL}	—	—	0.45	V	$I_{OL} = 1.6 \text{ mA}$
Input leakage current	$EO_7 - EO_0$, $EA_{16} - EA_0$, \overline{OE} , \overline{CE} , \overline{PGM}	$ I_{LI} $	—	—	2	μA	$V_{in} = 5.25 \text{ V}/0.5 \text{ V}$
V_{CC} current		I_{CC}	—	—	40	mA	
V_{PP} current		I_{PP}	—	—	40	mA	

Table 14-6 AC Characteristics(when $V_{CC} = 6.0 \text{ V} \pm 0.25 \text{ V}$, $V_{PP} = 12.5 \text{ V} \pm 0.3 \text{ V}$, $T_a = 25^\circ\text{C} \pm 5^\circ\text{C}$)

Item	Symbol	Min	Typ	Max	Unit	Test Conditions
Address setup time	t_{AS}	2	—	—	μs	See figure 14-6*
\overline{OE} setup time	t_{OES}	2	—	—	μs	
Data setup time	t_{DS}	2	—	—	μs	
Address hold time	t_{AH}	0	—	—	μs	
Data hold time	t_{DH}	2	—	—	μs	
Data output disable time	t_{DF}	—	—	130	ns	
V_{PP} setup time	t_{VPS}	2	—	—	μs	
Program pulse width	t_{PW}	0.19	0.20	0.21	ms	

Note: * Input pulse level: 0.8 V to 2.2 V

Input rise/fall time $\leq 20 \text{ ns}$

Timing reference levels: input—1.0 V, 2.0 V; output—0.8 V, 2.0 V

Table 14-6 AC Characteristics (cont)

(when $V_{CC} = 6.0 \text{ V} \pm 0.25 \text{ V}$, $V_{PP} = 12.5 \text{ V} \pm 0.3 \text{ V}$, $T_a = 25^\circ\text{C} \pm 5^\circ\text{C}$)

Item	Symbol	Min	Typ	Max	Unit	Test Conditions
$\overline{\text{OE}}$ pulse width for overwrite-programming	t_{OPW}	0.19	—	5.25	ms	See figure 14-6*
V_{CC} setup time	t_{VCS}	2	—	—	μs	
$\overline{\text{CE}}$ setup time	t_{CES}	2	—	—	μs	
Data output delay time	t_{OE}	0	—	150	ns	

Note: * Input pulse level: 0.8 V to 2.2 V

Input rise/fall time $\leq 20 \text{ ns}$

Timing reference levels: input—1.0 V, 2.0 V; output—0.8 V, 2.0 V

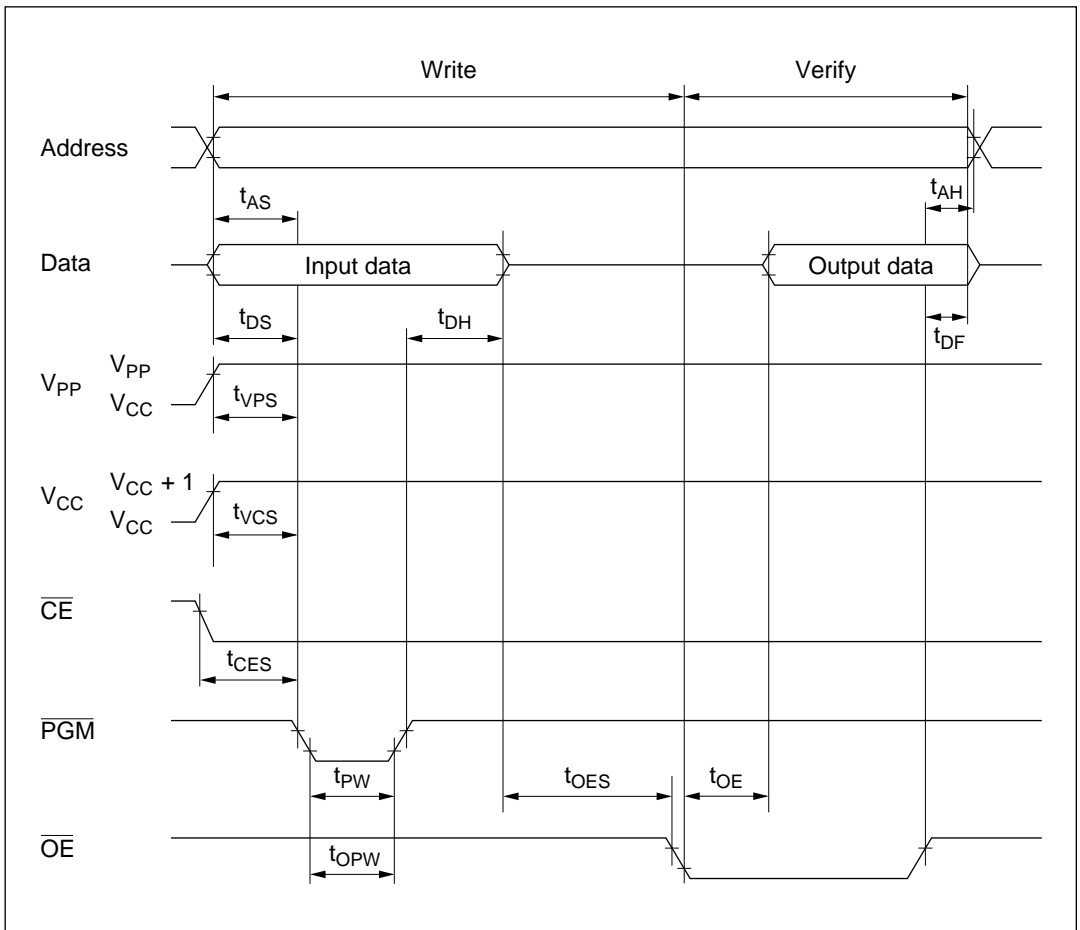

Figure 14-6 PROM Program/Verify Timing

14.3.2 Notes on Programming

(1) **Program with the specified voltages and timing. The programming voltage (V_{PP}) is 12.5 V.**

Caution: Applied voltages in excess of the specified values can permanently destroy the chip. Be particularly careful about the PROM programmer's overshoot characteristics.

If the PROM programmer is set to HN27C101 specifications, V_{PP} will be 12.5 V.

(2) **Before writing data, check that the socket adapter and chip are correctly mounted in the PROM writer.** Overcurrent damage to the chip can result if the index marks on the PROM programmer, socket adapter, and chip are not correctly aligned.

(3) **Don't touch the socket adapter or chip while writing.** Touching either of these can cause contact faults and write errors.

(4) **Page programming is not supported.** Do not select page programming mode.

(5) **The H8/3297 PROM size is 60 kbytes. The H8/3294 PROM size is 32 kbytes.** Set the address range to H'0000 to H'F77F for the H8/3297, and to H'0000 to H'7FFF for the H8/3294. When programming, specify H'FF data for unused address areas (H'F780 to H'1FFFF in the H8/3297, H'8000 to H'1FFFF in the H8/3294).

14.3.3 Reliability of Programmed Data

An effective way to assure the data holding characteristics of the programmed chips is to bake them at 150°C, then screen them for data errors. This procedure quickly eliminates chips with PROM memory cells prone to early failure.

Figure 14-7 shows the recommended screening procedure.

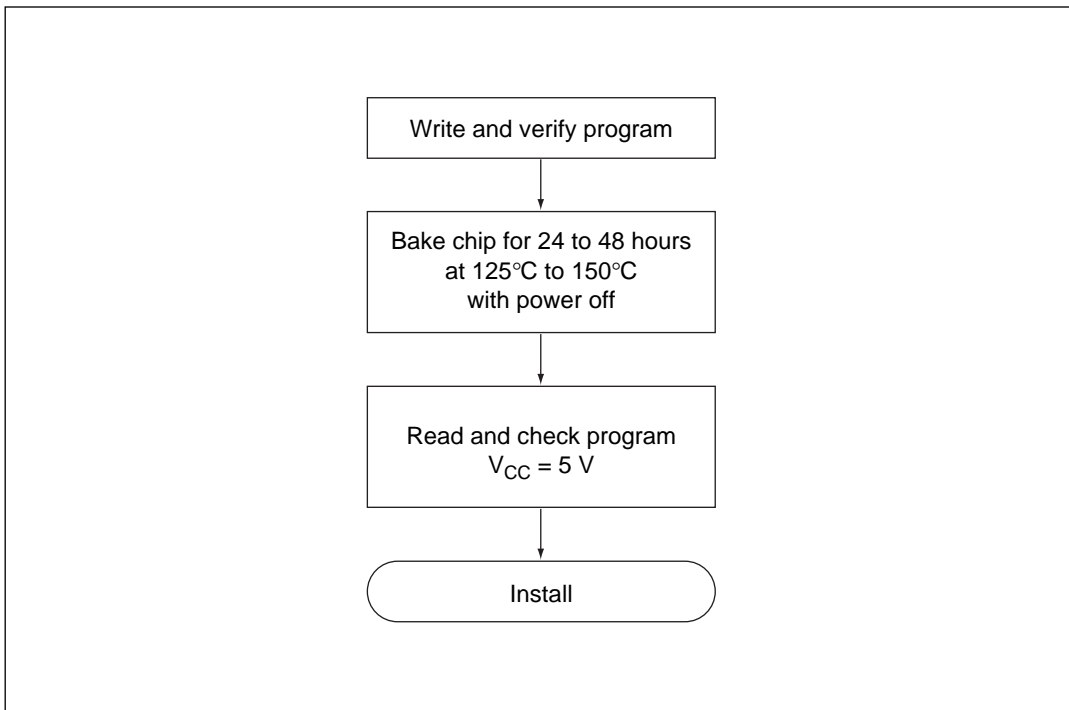

Figure 14-7 Recommended Screening Procedure

If a series of write errors occurs while the same PROM programmer is in use, stop programming and check the PROM programmer and socket adapter for defects, using a microcomputer chip with a windowed package and on-chip EPROM.

Please inform Hitachi of any abnormal conditions noted during programming or in screening of program data after high-temperature baking.

14.3.4 Erasing of Data

The windowed package enables data to be erased by illuminating the window with ultraviolet light. Table 14-7 lists the erasing conditions.

Table 14-7 Erasing Conditions

Item	Value
Ultraviolet wavelength	253.7 nm
Minimum illumination	15 W·s/cm ²

The conditions in table 14-7 can be satisfied by placing a 12000 μW/cm² ultraviolet lamp 2 or 3 centimeters directly above the chip and leaving it on for about 20 minutes.

14.4 Handling of Windowed Packages

(1) Grass Erasing Window: Rubbing the glass erasing window of a windowed package with a plastic material or touching it with an electrically charged object can create a static charge on the window surface which may cause the chip to malfunction.

If the erasing window becomes charged, the charge can be neutralized by a short exposure to ultraviolet light. This returns the chip to its normal condition, but it also reduces the charge stored in the floating gates of the PROM, so it is recommended that the chip be reprogrammed afterward.

Accumulation of static charge on the window surface can be prevented by the following precautions:

1. When handling the package, ground yourself. Don't wear gloves. Avoid other possible sources of static charge.
2. Avoid friction between the glass window and plastic or other materials that tend to accumulate static charge.
3. Be careful when using cooling sprays, since they may have a slight ionic content.
4. Cover the window with an ultraviolet-shield label, preferably a label including a conductive material. Besides protecting the PROM contents from ultraviolet light, the label protects the chip by distributing static charge uniformly.

(2) Handling after Programming: Fluorescent light and sunlight contain small amounts of ultraviolet, so prolonged exposure to these types of light can cause programmed data to invert. In addition, exposure to any type of intense light can induce photoelectric effects that may lead to chip malfunction. It is recommended that after programming the chip, you cover the erasing window with a light-proof label (such as an ultraviolet-shield label).

Section 15 Power-Down State

15.1 Overview

The H8/3297 Series has a power-down state that greatly reduces power consumption by stopping some or all of the chip functions. The power-down state includes three modes:

- (1) Sleep mode
- (2) Software standby mode
- (3) Hardware standby mode

Table 15-1 lists the conditions for entering and leaving the power-down modes. It also indicates the status of the CPU, on-chip supporting modules, etc. in each power-down mode.

Table 15-1 Power-Down State

Mode	Entering Procedure	Clock	CPU	Reg's.	CPU Mod.	Sup. RAM	I/O Ports	Exiting Methods
Sleep mode	Execute SLEEP instruction	Run	Halt	Held	Run	Held	Held	<ul style="list-style-type: none"> • Interrupt • $\overline{\text{RES}}$ • $\overline{\text{STBY}}$
Software standby mode	Set SSBY bit in SYSCR to 1, then execute SLEEP instruction	Halt	Halt	Held	Halt and initialized	Held	Held	<ul style="list-style-type: none"> • $\overline{\text{NMI}}$ • $\overline{\text{IRQ}}_0$ to $\overline{\text{IRQ}}_2$ • $\overline{\text{RES}}$ • $\overline{\text{STBY}}$
Hardware standby mode	Set $\overline{\text{STBY}}$ pin to low level	Halt	Halt	Not held	Halt and initialized	Held	High impedance state	<ul style="list-style-type: none"> • $\overline{\text{STBY}}$ and $\overline{\text{RES}}$

Notes: 1. SYSCR: System control register
 2. SSBY: Software standby bit

15.1.1 System Control Register (SYSCR)

Four of the eight bits in the system control register (SYSCR) control the power-down state. These are bit 7 (SSBY) and bits 6 to 4 (STS2 to STS0). See table 15-2.

Table 15-2 System Control Register

Name	Abbreviation	R/W	Initial Value	Address
System control register	SYSCR	R/W	H'0B	H'FFC4

Bit	7	6	5	4	3	2	1	0
	SSBY	STS2	STS1	STS0	XRST	NMIEG	—	RAME
Initial value	0	0	0	0	1	0	1	1
Read/Write	R/W	R/W	R/W	R/W	R	R/W	—	R/W

Bit 7—Software Standby (SSBY): This bit enables or disables the transition to software standby mode.

On recovery from the software standby mode by an external interrupt, SSBY remains set to 1. To clear this bit, software must write a 0.

Bit 7

SSBY	Description
0	The SLEEP instruction causes a transition to sleep mode. (Initial value)
1	The SLEEP instruction causes a transition to software standby mode.

Bits 6 to 4—Standby Timer Select 2 to 0 (STS2 to STS0): These bits select the clock settling time when the chip recovers from software standby mode by an external interrupt. During the selected time, the clock oscillator runs but the CPU and on-chip supporting modules remain in standby. Set bits STS2 to STS0 according to the clock frequency to obtain a settling time of at least 8 ms. See table 15-3.

Bit 6 STS2	Bit 5 STS1	Bit 4 STS0	Description
0	0	0	Settling time = 8,192 states (Initial value)
0	0	1	Settling time = 16,384 states
0	1	0	Settling time = 32,768 states
0	1	1	Settling time = 65,536 states
1	0	—	Settling time = 131,072 states
1	1	—	Disabled

15.2 Sleep Mode

15.2.1 Transition to Sleep Mode

When the SSBY bit in the system control register is cleared to 0, execution of the SLEEP instruction causes a transition from the program execution state to sleep mode. After executing the SLEEP instruction, the CPU halts, but the contents of its internal registers remain unchanged. The on-chip supporting modules continue to operate normally.

15.2.2 Exit from Sleep Mode

The chip exits sleep mode when it receives an internal or external interrupt request, or a low input at the $\overline{\text{RES}}$ or $\overline{\text{STBY}}$ pin.

(1) **Exit by Interrupt:** An interrupt releases sleep mode and starts the CPU's interrupt-handling sequence.

If an interrupt from an on-chip supporting module is disabled by the corresponding enable/disable bit in the module's control register, the interrupt cannot be requested, so it cannot wake the chip up. Similarly, the CPU cannot be awoken by an interrupt other than NMI if the I (interrupt mask) bit is set when the SLEEP instruction is executed.

(2) **Exit by $\overline{\text{RES}}$ pin:** When the $\overline{\text{RES}}$ pin goes low, the chip exits from sleep mode to the reset state.

(3) **Exit by $\overline{\text{STBY}}$ pin:** When the $\overline{\text{STBY}}$ pin goes low, the chip exits from sleep mode to hardware standby mode.

15.3 Software Standby Mode

15.3.1 Transition to Software Standby Mode

To enter software standby mode, set the standby bit (SSBY) in the system control register (SYSCR) to 1, then execute the SLEEP instruction.

In software standby mode, the system clock stops and chip functions halt, including both CPU functions and the functions of the on-chip supporting modules. Power consumption is reduced to an extremely low level. The on-chip supporting modules and their registers are reset to their initial states, but as long as a minimum necessary voltage supply is maintained, the contents of the CPU registers and on-chip RAM remain unchanged.

15.3.2 Exit from Software Standby Mode

The chip can be brought out of software standby mode by by $\overline{\text{RES}}$ input, $\overline{\text{STBY}}$ input, or external interrupt input at the $\overline{\text{NMI}}$ pin, $\overline{\text{IRQ}}_0$ to $\overline{\text{IRQ}}_2$ pins.

(1) Exit by Interrupt: When an NMI, $\overline{\text{IRQ}}_0$, $\overline{\text{IRQ}}_1$, or $\overline{\text{IRQ}}_2$ interrupt request signal is input, the clock oscillator begins operating. After the waiting time set in bits STS2 to STS0 of SYSCR, a stable clock is supplied to the entire chip, software standby mode is released, and interrupt exception-handling begins.

(2) Exit by $\overline{\text{RES}}$ Pin: When the $\overline{\text{RES}}$ input goes low, the clock oscillator begins operating. When $\overline{\text{RES}}$ is brought to the high level (after allowing time for the clock oscillator to settle), the CPU starts reset exception handling. Be sure to hold $\overline{\text{RES}}$ low long enough for clock oscillation to stabilize.

(3) Exit by $\overline{\text{STBY}}$ Pin: When the $\overline{\text{STBY}}$ input goes low, the chip exits from software standby mode to hardware standby mode.

15.3.3 Clock Settling Time for Exit from Software Standby Mode

Set bits STS2 to STS0 in SYSCR as follows:

- Crystal oscillator

Set STS2 to STS0 for a settling time of at least 10 ms. Table 15-3 lists the settling times selected by these bits at several clock frequencies.

- External clock

The STS bits can be set to any value. Normally, use of the minimum time is recommended (STS2 = STS1 = STS0 = 0).

Table 15-3 Times Set by Standby Timer Select Bits (Unit: ms)

STS2	STS1	STS0	Settling Time (States)	System Clock Frequency (MHz)								
				16	12	10	8	6	4	2	1	0.5
0	0	0	8,192	0.51	0.65	0.8	1.0	1.3	2.0	4.1	8.2	16.4
0	0	1	16,384	1.0	1.3	1.6	2.0	2.7	4.1	8.2	16.4	32.8
0	1	0	32,768	2.0	2.7	3.3	4.1	5.5	8.2	16.4	32.8	65.5
0	1	1	65,536	4.1	5.5	6.6	8.2	10.9	16.4	32.8	65.5	131.1
1	0	—	131,072	8.2	10.9	13.1	16.4	21.8	32.8	65.5	131.1	262.1

- Notes:
1. All times are in milliseconds.
 2. Recommended values are printed in boldface.

15.3.4 Sample Application of Software Standby Mode

In this example the chip enters the software standby mode when $\overline{\text{NMI}}$ goes low and exits when $\overline{\text{NMI}}$ goes high, as shown in figure 15-1.

The NMI edge bit (NMIEG) in the system control register is originally cleared to 0, selecting the falling edge. When $\overline{\text{NMI}}$ goes low, the $\overline{\text{NMI}}$ interrupt handling routine sets NMIEG to 1, sets SSBY to 1 (selecting the rising edge), then executes the SLEEP instruction. The chip enters software standby mode. It recovers from software standby mode on the next rising edge of $\overline{\text{NMI}}$.

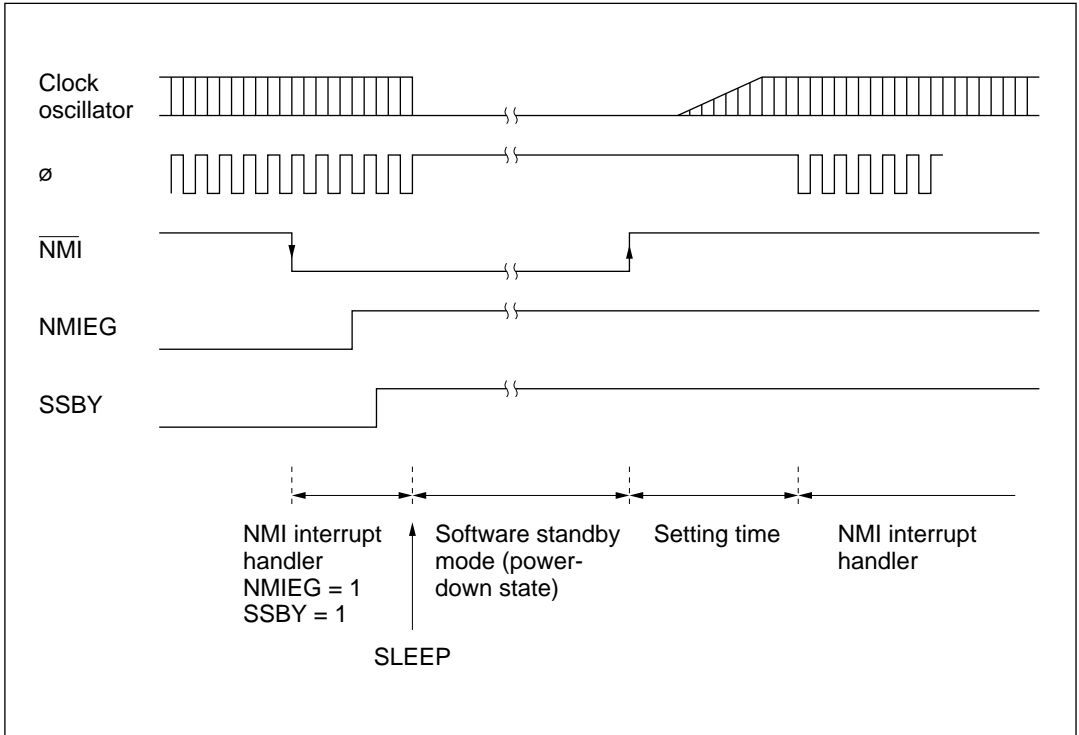

Figure 15-1 NMI Timing in Software Standby Mode

15.3.5 Usage Note

The I/O ports retain their current states in software standby mode. If a port is in the high output state, the current dissipation caused by the output current is not reduced.

15.4 Hardware Standby Mode

15.4.1 Transition to Hardware Standby Mode

Regardless of its current state, the chip enters hardware standby mode whenever the $\overline{\text{STBY}}$ pin goes low.

Hardware standby mode reduces power consumption drastically by halting the CPU, stopping all the functions of the on-chip supporting modules, and placing I/O ports in the high-impedance state. The registers of the on-chip supporting modules are reset to their initial values. Only the on-chip RAM is held unchanged, provided the minimum necessary voltage supply is maintained.

- Notes:
1. The RAME bit in the system control register should be cleared to 0 before the $\overline{\text{STBY}}$ pin goes low.
 2. Do not change the inputs at the mode pins ($\overline{\text{MD}}_1$, $\overline{\text{MD}}_0$) during hardware standby mode. Be particularly careful not to let both mode pins go low in hardware standby mode, since that places the chip in PROM mode and increases current dissipation.

15.4.2 Recovery from Hardware Standby Mode

Recovery from the hardware standby mode requires inputs at both the $\overline{\text{STBY}}$ and $\overline{\text{RES}}$ pins. When the $\overline{\text{STBY}}$ pin goes high, the clock oscillator begins running. The $\overline{\text{RES}}$ pin should be low at this time and should be held low long enough for the clock to stabilize. When the $\overline{\text{RES}}$ pin changes from low to high, the reset sequence is executed and the chip returns to the program execution state.

15.4.3 Timing Relationships

Figure 15-2 shows the timing relationships in hardware standby mode.

In the sequence shown, first $\overline{\text{RES}}$ goes low, then $\overline{\text{STBY}}$ goes low, at which point the chip enters hardware standby mode. To recover, first $\overline{\text{STBY}}$ goes high, then after the clock settling time, $\overline{\text{RES}}$ goes high.

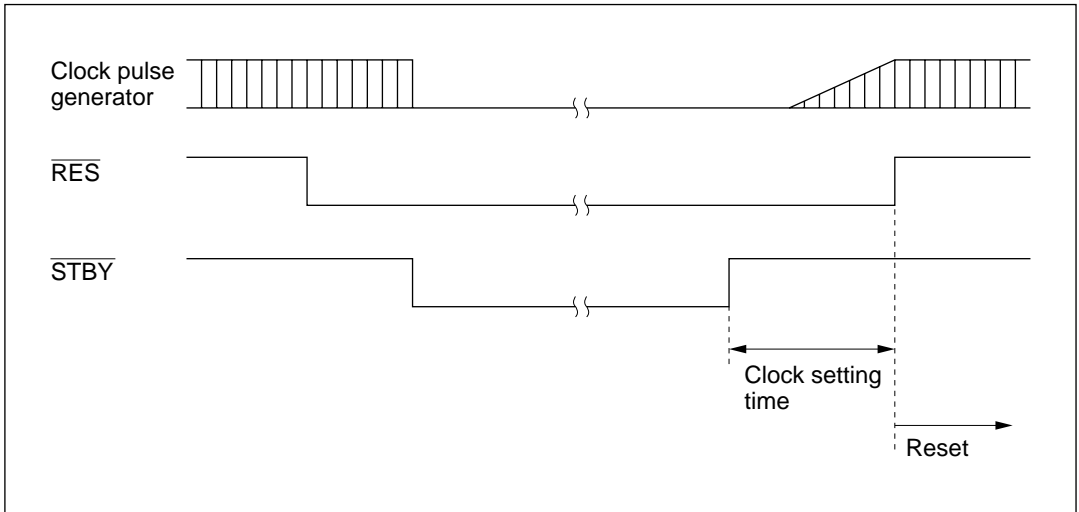

Figure 15-2 Hardware Standby Mode Timing

Section 16 Electrical Specifications

16.1 Absolute Maximum Ratings

Table 16-1 lists the absolute maximum ratings.

Table 16-1 Absolute Maximum Ratings

Item	Symbol	Rating	Unit	
Supply voltage	V_{CC}	-0.3 to +7.0	V	
Programming voltage	V_{PP}	-0.3 to +13.5	V	
Input voltage	Ports 1 to 6	V_{in}	-0.3 to $V_{CC} + 0.3$	V
	Port 7	V_{in}	-0.3 to $AV_{CC} + 0.3$	V
Analog supply voltage	AV_{CC}	-0.3 to +7.0	V	
Analog input voltage	V_{AN}	-0.3 to $AV_{CC} + 0.3$	V	
Operating temperature	T_{opr}	Regular specifications: -20 to +75	°C	
		Wide-range specifications: -40 to +85	°C	
Storage temperature	T_{stg}	-55 to +125	°C	

Note: Exceeding the absolute maximum ratings shown in table 16-1 can permanently destroy the chip.

16.2 Electrical Characteristics

16.2.1 DC Characteristics

The DC characteristics of the 5 V, 4 V, and 3 V versions are shown in tables 16-2, 16-3, and 16-4 respectively. The allowable output current values for the 5 V and 4 V versions are shown in table 16-5, and those for the 3 V version in table 16-6.

Table 16-2 DC Characteristics (5-V Version)Conditions: $V_{CC} = 5.0\text{ V} \pm 10\%$, $AV_{CC} = 5.0\text{ V} \pm 10\%$ *1, $V_{SS} = AV_{SS} = 0\text{ V}$, $T_a = -20\text{ to }75^\circ\text{C}$ (regular specifications), $T_a = -40\text{ to }85^\circ\text{C}$ (wide-range specifications)

Item	Symbol	Min	Typ	Max	Unit	Test Conditions
Schmitt trigger input voltage (1)	$\overline{P6_7}$ to $\overline{P6_0}$ *4, $\overline{IRQ_2}$ to $\overline{IRQ_0}$ *5	V_{T^-}	1.0	—	—	V
		V_{T^+}	—	—	$V_{CC} \times 0.7$	
		$V_{T^+} - V_{T^-}$	0.4	—	—	
Input high voltage (2)	\overline{RES} , \overline{STBY} , \overline{NMI} MD_1 , MD_0 EXTAL	V_{IH}	$V_{CC} - 0.7$	—	$V_{CC} + 0.3$	V
	$P7_7$ to $P7_0$		2.0	—	$AV_{CC} + 0.3$	
Input high voltage	Input pins other than (1) and (2)	V_{IH}	2.0	—	$V_{CC} + 0.3$	
Input low voltage (3)	\overline{RES} , \overline{STBY} MD_1 , MD_0	V_{IL}	-0.3	—	0.5	V
Input low voltage	Input pins other than (1) and (3) above	V_{IL}	-0.3	—	0.8	
Output high voltage	All output pins	V_{OH}	$V_{CC} - 0.5$ 3.5	— —	— —	V $I_{OH} = -200\ \mu\text{A}$ $I_{OH} = -1.0\ \text{mA}$
Output low voltage	All output pins	V_{OL}	—	—	0.4	V $I_{OL} = 1.6\ \text{mA}$
	Ports 1 and 2		—	—	1.0	$I_{OL} = 10.0\ \text{mA}$
Input leakage current	\overline{RES} , \overline{STBY}	$ I_{in} $	—	—	10.0	μA $V_{in} = 0.5\ \text{V}$ to $V_{CC} - 0.5\ \text{V}$
	\overline{NMI} , MD_1 , MD_0		—	—	1.0	
	$P7_7$ to $P7_0$		—	—	1.0	$V_{in} = 0.5\ \text{V}$ to $AV_{CC} - 0.5\ \text{V}$
Leakage current in 3-state (off state)	Ports 1 to 6	$ I_{TSI} $	—	—	1.0	μA $V_{in} = 0.5\ \text{V}$ to $V_{CC} - 0.5\ \text{V}$
Input pull-up MOS current	Ports 1, 2, 3	$-I_p$	30	—	250	μA $V_{in} = 0\ \text{V}$

Refer to notes at the end of the table.

Table 16-2 DC Characteristics (5-V Version) (cont)

Conditions: $V_{CC} = 5.0\text{ V} \pm 10\%$, $AV_{CC} = 5.0\text{ V} \pm 10\%^{*1}$, $V_{SS} = AV_{SS} = 0\text{ V}$, $T_a = -20\text{ to }75^\circ\text{C}$ (regular specifications), $T_a = -40\text{ to }85^\circ\text{C}$ (wide-range specifications)

Item		Symbol	Min	Typ	Max	Unit	Test Conditions
Input capacitance	$\overline{\text{RES}}$, $\overline{\text{STBY}}$	C_{in}	—	—	60	pF	$V_{in} = 0\text{ V}$ $f = 1\text{ MHz}$ $T_a = 25^\circ\text{C}$
	$\overline{\text{NMI}}$, MD_1		—	—	30		
	All input pins except $\overline{\text{RES}}$, $\overline{\text{STBY}}$, $\overline{\text{NMI}}$ and MD_1		—	—	15		
Current dissipation*2	Normal operation	I_{CC}	—	27	45	mA	$f = 12\text{ MHz}$
			—	36	60		$f = 16\text{ MHz}$
	Sleep mode		—	18	30		$f = 12\text{ MHz}$
			—	24	40		$f = 16\text{ MHz}$
	Standby modes*3		—	0.01	5.0	μA	$T_a \leq 50^\circ\text{C}$
—			—	20.0	μA	$50^\circ\text{C} < T_a$	
Analog supply current	During A/D conversion	AI_{CC}	—	2.0	5.0	mA	
	Waiting		—	0.01	5.0		μA
Analog supply voltage*1		AV_{CC}	4.5	—	5.5	V	During operation
			2.0	—	5.5		During wait state or when not in use
RAM standby voltage		V_{RAM}	2.0	—	—	V	

- Notes: 1. Even when the A/D converter is not used, connect AV_{CC} to power supply V_{CC} and keep the applied voltage between 2.0 V and 5.5 V.
2. Current dissipation values assume that $V_{IH\ min} = V_{CC} - 0.5\text{ V}$, $V_{IL\ max} = 0.5\text{ V}$, all output pins are in the no-load state, and all input pull-up transistors are off.
3. For these values it is assumed that $V_{RAM} \leq V_{CC} < 4.5\text{ V}$ and $V_{IH\ min} = V_{CC} \times 0.9$, $V_{IL\ max} = 0.3\text{ V}$.
4. $\overline{\text{P6}}_7$ to $\overline{\text{P6}}_0$ include supporting module inputs multiplexed with them.
5. $\overline{\text{IRQ}}_2$ includes $\overline{\text{ADTRG}}$ multiplexed with it.

Table 16-3 DC Characteristics (4-V Version)Conditions: $V_{CC} = 4.0\text{ V to }5.5\text{ V}$, $AV_{CC} = 4.0\text{ V to }5.5\text{ V}^{*1}$, $V_{SS} = AV_{SS} = 0\text{ V}$, $T_a = -20\text{ to }75^\circ\text{C}$ (regular specifications), $T_a = -40\text{ to }85^\circ\text{C}$ (wide-range specifications)

Item		Symbol	Min	Typ	Max	Unit	Test Conditions	
Schmitt trigger input voltage (1)	$P6_7$ to $P6_0$ *4, IRQ_2 to IRQ_0 *5	V_{T^-}	1.0	—	—	V	$V_{CC} = 4.5\text{ V to }5.5\text{ V}$	
		V_{T^+}	—	—	$V_{CC} \times 0.7$			
			$V_{T^+} - V_{T^-}$	0.4	—	—		
			V_{T^-}	0.8	—	—		$V_{CC} = 4.0\text{ V to }4.5\text{ V}$
			V_{T^+}	—	—	$V_{CC} \times 0.7$		
			$V_{T^+} - V_{T^-}$	0.3	—	—		
Input high voltage (2)	\overline{RES} , \overline{STBY} , \overline{NMI} MD_1 , MD_0 EXTAL	V_{IH}	$V_{CC} - 0.7$	—	$V_{CC} + 0.3$	V		
	$P7_7$ to $P7_0$							
Input high voltage	Input pins other than (1) and (2)		2.0	—	$AV_{CC} + 0.3$			
Input low voltage (3)	\overline{RES} , \overline{STBY} MD_1 , MD_0	V_{IL}	-0.3	—	0.5	V		
	Input pins other than (1) and (3) above							
Input low voltage	Input pins other than (1) and (3) above		-0.3	—	0.8		$V_{CC} = 4.5\text{ V to }5.5\text{ V}$	
			-0.3	—	0.6		$V_{CC} = 4.0\text{ V to }4.5\text{ V}$	
Output high voltage	All output pins	V_{OH}	$V_{CC} - 0.5$	—	—	V	$I_{OH} = -200\ \mu\text{A}$	
			3.5	—	—		$I_{OH} = -1.0\text{ mA}$ $V_{CC} = 4.5\text{ V to }5.5\text{ V}$	
			2.8	—	—		$I_{OH} = -1.0\text{ mA}$ $V_{CC} = 4.0\text{ V to }4.5\text{ V}$	
Output low voltage	All output pins	V_{OL}	—	—	0.4	V	$I_{OL} = 1.6\text{ mA}$	
	$P1_7$ to $P1_0$, $P2_7$ to $P2_0$		—	—	1.0		$I_{OL} = 10.0\text{ mA}$	
Input leakage current	\overline{RES} , \overline{STBY}	$ I_{in} $	—	—	10.0	V	$V_{in} = 0.5\text{ V to }V_{CC} - 0.5\text{ V}$	
	\overline{NMI} , MD_1 , MD_0		—	—	1.0			
	$P7_7$ to $P7_0$		—	—	1.0	μA	$V_{in} = 0.5\text{ V to }AV_{CC} - 0.5\text{ V}$	

Refer to notes at the end of the table.

Table 16-3 DC Characteristics (4-V Version) (cont)

Conditions: $V_{CC} = 4.0\text{ V to }5.5\text{ V}$, $AV_{CC} = 4.0\text{ V to }5.5\text{ V}^{*1}$, $V_{SS} = AV_{SS} = 0\text{ V}$,
 $T_a = -20\text{ to }75^\circ\text{C}$ (regular specifications), $T_a = -40\text{ to }85^\circ\text{C}$ (wide-range specifications)

Item		Symbol	Min	Typ	Max	Unit	Test Conditions
Leakage current in 3-state (off state)	Ports 1 to 6	$ I_{TSI} $	—	—	1.0	μA	$V_{in} = 0.5\text{ V to }V_{CC} - 0.5\text{ V}$
Input pull-up MOS current	Ports 1, 2, 3	-Ip	30	—	250	μA	$V_{in} = 0\text{ V}$ $V_{CC} = 4.5\text{ V to }5.5\text{ V}$
			20	—	200		$V_{in} = 0\text{ V}$ $V_{CC} = 4.0\text{ V to }4.5\text{ V}$
Input capacitance	$\overline{\text{RES}}, \overline{\text{STBY}}$	C_{in}	—	—	60	pF	$V_{in} = 0\text{ V}$ $f = 1\text{ MHz}$ $T_a = 25^\circ\text{C}$
	$\overline{\text{NMI}}, \text{MD}_1$		—	—	30		
	All input pins except $\overline{\text{RES}}$, $\overline{\text{STBY}}$, $\overline{\text{NMI}}$ and MD_1		—	—	15		
Current dissipation*2	Normal operation	I_{CC}	—	27	45	mA	$f = 12\text{ MHz}$
			—	36	60		$f = 16\text{ MHz}$ $V_{CC} = 4.5\text{ V to }5.5\text{ V}$
	Sleep mode		—	18	30	μA	$f = 12\text{ MHz}$
			—	24	40		$f = 16\text{ MHz}$ $V_{CC} = 4.5\text{ V to }5.5\text{ V}$
	Standby modes*3		—	0.01	5.0	μA	$T_a \leq 50^\circ\text{C}$
			—	—	20.0		$50^\circ\text{C} < T_a$
Analog supply current	During A/D conversion	AI_{CC}	—	2.0	5.0	mA	$AV_{CC} = 2.0\text{ V to }5.5\text{ V}$
	Waiting		—	0.01	5.0		
Analog supply voltage*1		AV_{CC}	4.0	—	5.5	V	During operation
			2.0	—	5.5		During wait state or when not in use
RAM standby voltage		V_{RAM}	2.0	—	—	V	

Refer to notes at the end of the table.

- Notes:
1. Even when the A/D converter is not used, connect AV_{CC} to power supply V_{CC} and keep the applied voltage between 2.0 V and 5.5 V.
 2. Current dissipation values assume that $V_{IH\ min} = V_{CC} - 0.5\ V$, $V_{IL\ max} = 0.5\ V$, all output pins are in the no-load state, and all input pull-up transistors are off.
 3. For these values it is assumed that $V_{RAM} \leq V_{CC} < 4.0\ V$ and $V_{IH\ min} = V_{CC} \times 0.9$, $V_{IL\ max} = 0.3\ V$.
 4. $P6_7$ to $P6_0$ include supporting module inputs multiplexed with them.
 5. \overline{IRQ}_2 includes \overline{ADTRG} multiplexed with it.

Table 16-4 DC Characteristics (3-V Version)Conditions: $V_{CC} = 2.7\text{ V to }5.5\text{ V}$, $AV_{CC} = 2.7\text{ V to }5.5\text{ V}^{*1}$, $V_{SS} = AV_{SS} = 0\text{ V}$, $T_a = -20\text{ to }75^\circ\text{C}$

Item		Symbol	Min	Typ	Max	Unit	Test Conditions
Schmitt trigger input voltage (1)	P6 ₇ to P6 ₀ ^{*4} , IRQ ₂ to IRQ ₀ ^{*5}	V_{T^-}	$V_{CC} \times 0.15$	—	—	V	
		V_{T^+}	—	—	$V_{CC} \times 0.7$		
		$V_{T^+} - V_{T^-}$	0.2	—	—		
Input high voltage (2)	RES, STBY MD ₁ , MD ₀ EXTAL, NMI	V_{IH}	$V_{CC} \times 0.9$	—	$V_{CC} + 0.3$	V	
	P7 ₇ to P7 ₀						
Input high voltage	Input pins other than (1) and (2) above		$V_{CC} \times 0.7$	—	$V_{CC} + 0.3$		
Input low voltage (3)	RES, STBY MD ₁ , MD ₀	V_{IL}	-0.3	—	$V_{CC} \times 0.1$	V	
Input low voltage	Input pins other than (1) and (3) above						
Output high voltage	All output pins	V_{OH}	$V_{CC} - 0.5$	—	—	V	$I_{OH} = -200\ \mu\text{A}$
							$V_{CC} - 1.0$
Output low voltage	All output pins	V_{OL}	—	—	0.4	V	$I_{OL} = 0.8\ \text{mA}$
	Ports 1 and 2						—
Input leakage current	RES, STBY	$ I_{in} $	—	—	10.0	μA	$V_{in} = 0.5\ \text{V to } V_{CC} - 0.5\ \text{V}$
	NMI, MD ₁ , MD ₀				1.0		
	P7 ₇ to P7 ₀				1.0		
Leakage current in 3-state (off state)	Ports 1 to 6	$ I_{TSI} $	—	—	1.0	μA	$V_{in} = 0.5\ \text{V to } V_{CC} - 0.5\ \text{V}$
Input pull-up MOS current	Ports 1, 2, 3	$-I_p$	3	—	120	μA	$V_{in} = 0\ \text{V}$, $V_{CC} = 2.7\ \text{V to } 4.0\ \text{V}$

Refer to notes at the end of the table.

Table 16-4 DC Characteristics (3-V Version) (cont)Conditions: $V_{CC} = 2.7\text{ V to }5.5\text{ V}$, $AV_{CC} = 2.7\text{ V to }5.5\text{ V}^{*1}$, $V_{SS} = AV_{SS} = 0\text{ V}$, $T_a = -20\text{ to }75^\circ\text{C}$

Item		Symbol	Min	Typ	Max	Unit	Test Conditions
Input capacitance	$\overline{\text{RES}}, \text{STBY}$	C_{in}	—	—	60	pF	$V_{in} = 0\text{ V}$ $f = 1\text{ MHz}$ $T_a = 25^\circ\text{C}$
	NMI, MD_1		—	—	30		
	All input pins except $\overline{\text{RES}}, \text{STBY}, \text{NMI}$ and MD_1		—	—	15		
Current dissipation*2	Normal operation	I_{CC}	—	7	—	mA	$f = 6\text{ MHz}$ $V_{CC} = 2.7\text{ V to }3.6\text{ V}$
			—	12	22		$f = 10\text{ MHz}$, $V_{CC} = 2.7\text{ V to }3.6\text{ V}$
			—	25	—		$f = 10\text{ MHz}$, $V_{CC} = 4.0\text{ V to }5.5\text{ V}$
	Sleep mode		—	5	—		$f = 6\text{ MHz}$ $V_{CC} = 2.7\text{ V to }3.6\text{ V}$
			—	9	16		$f = 10\text{ MHz}$ $V_{CC} = 2.7\text{ V to }3.6\text{ V}$
			—	18	—		$f = 10\text{ MHz}$ $V_{CC} = 4.0\text{ V to }5.5\text{ V}$
			Standby modes*3	—	0.01		5.0
—	—	20.0		μA	$50^\circ\text{C} < T_a$		
Analog supply current	During A/D conversion	AI_{CC}	—	2.0	5.0	mA	
	Waiting		—	0.01	5.0		
Analog supply voltage*1		AV_{CC}	2.7	—	5.5	V	During operation
			2.0	—	5.5		During wait state or when not in use
RAM backup voltage (in standby modes)		V_{RAM}	2.0	—	—	V	

- Notes: 1. Even when the A/D converter is not used, connect AV_{CC} to power supply V_{CC} and keep the applied voltage between 2.0 V and 5.5 V.
2. Current dissipation values assume that $V_{IH\ min} = V_{CC} - 0.5\text{ V}$, $V_{IL\ max} = 0.5\text{ V}$, all output pins are in the no-load state, and all input pull-up transistors are off.
3. For these values it is assumed that $V_{RAM} \leq V_{CC} < 2.7\text{ V}$ and $V_{IH\ min} = V_{CC} \times 0.9$, $V_{IL\ max} = 0.3\text{ V}$.
4. P6_7 to P6_0 include supporting module inputs multiplexed with them.
5. IRQ_2 includes ADTRG multiplexed with it.

Table 16-5 Allowable Output Current Values (5-V Version 4-V Version)

Conditions: $V_{CC} = 4.0\text{ V to }5.5\text{V}$, $AV_{CC} = 4.0\text{ V to }5.5\text{V}$, $V_{SS} = AV_{SS} = 0\text{ V}$,
 $T_a = -20\text{ to }75^\circ\text{C}$ (regular specifications), $T_a = -40\text{ to }85^\circ\text{C}$ (wide-range specifications)

Item		Symbol	Min	Typ	Max	Unit
Allowable output low	Ports 1 and 2	I_{OL}	—	10	—	mA
	Other output pins		—	—	2	
Allowable output low current (total)	Ports 1 and 2, total	ΣI_{OL}	—	—	80	mA
	Total of all output		—	—	120	
Allowable output high current (per pin)	All output pins	$-I_{OH}$	—	—	2	mA
Allowable output high current (total)	Total of all output	$\Sigma -I_{OH}$	—	—	40	mA

Table 16-6 Allowable Output Current Values (3-V Version)

Conditions: $V_{CC} = 2.7\text{ to }5.5\text{ V}$, $AV_{CC} = 2.7\text{ V to }5.5\text{ V}$, $V_{SS} = AV_{SS} = 0\text{ V}$, $T_a = -20\text{ to }75^\circ\text{C}$

Item		Symbol	Min	Typ	Max	Unit
Allowable output low	Ports 1 and 2	I_{OL}	—	—	2	mA
	Other output pins		—	—	1	
Allowable output low current (total)	Ports 1 and 2, total	ΣI_{OL}	—	—	40	mA
	Total of all output		—	—	60	
Allowable output high current (per pin)	All output pins	$-I_{OH}$	—	—	2	mA
Allowable output high current (total)	Total of all output	$\Sigma -I_{OH}$	—	—	30	mA

Note: To avoid degrading the reliability of the chip, be careful not to exceed the output current values in tables 16-5 and 16-6. In particular, when driving a darlington transistor pair or LED directly, be sure to insert a current-limiting resistor in the output path. See figures 16-1 and 16-2.

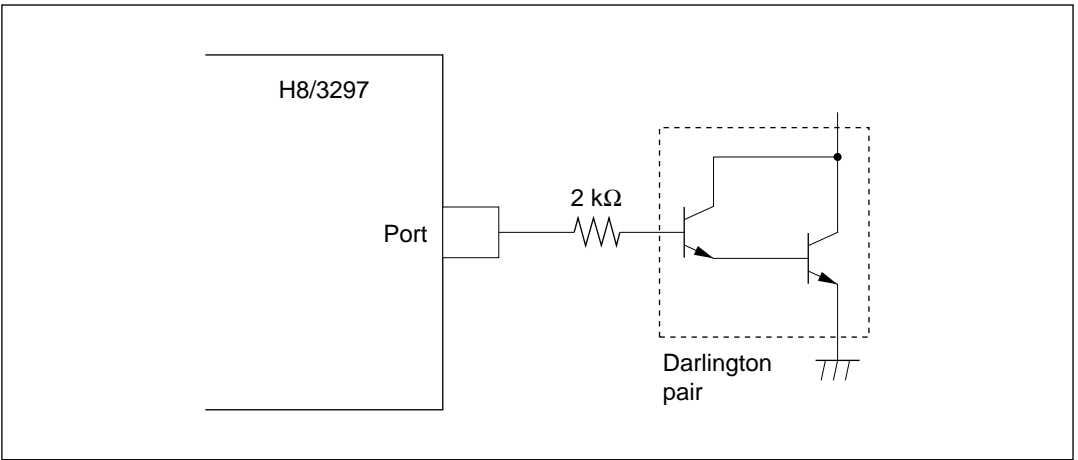

Figure 16-1 Example of Circuit for Driving a Darlington Pair (5-V Version)

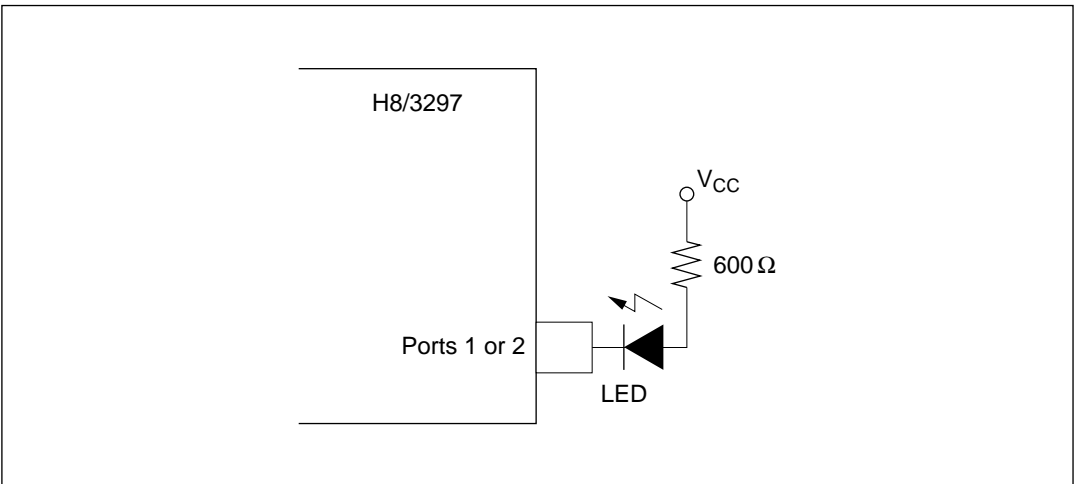

Figure 16-2 Example of Circuit for Driving an LED (5-V Version)

16.2.2 AC Characteristics

The AC characteristics are listed in three tables. Bus timing parameters are given in table 16-7, control signal timing parameters in table 16-8, and timing parameters of the on-chip supporting modules in table 16-9.

Table 16-7 Bus Timing

Condition A: $V_{CC} = 5.0\text{ V} \pm 10\%$, $V_{SS} = 0\text{ V}$, $\phi = 2.0\text{ MHz}$ to maximum operating frequency,
 $T_a = -20\text{ to }75^\circ\text{C}$ (regular specifications),
 $T_a = -40\text{ to }85^\circ\text{C}$ (wide-range specifications)

Condition B: $V_{CC} = 4.0\text{ V to }5.5\text{ V}$, $V_{SS} = 0\text{ V}$, $\phi = 2.0\text{ MHz}$ to maximum operating frequency,
 $T_a = -20\text{ to }75^\circ\text{C}$ (regular specifications),
 $T_a = -40\text{ to }85^\circ\text{C}$ (wide-range specifications)

Condition C: $V_{CC} = 2.7\text{ V to }5.5\text{ V}$, $V_{SS} = 0\text{ V}$, $\phi = 2.0\text{ MHz}$ to maximum operating frequency,
 $T_a = -20\text{ to }75^\circ\text{C}$

Item	Symbol	Condition C		Condition B		Condition A		Unit	Test Conditions
		10 MHz		12 MHz		16 MHz			
		Min	Max	Min	Max	Min	Max		
Clock cycle time	t_{cyc}	100	500	83.3	500	62.5	500	ns	Fig. 16-4
Clock pulse width low	t_{CL}	30	–	30	–	20	–	ns	Fig. 16-4
Clock pulse width high	t_{CH}	30	–	30	–	20	–	ns	Fig. 16-4
Clock rise time	t_{Cr}	–	20	–	10	–	10	ns	Fig. 16-4
Clock fall time	t_{Cf}	–	20	–	10	–	10	ns	Fig. 16-4
Address delay time	t_{AD}	–	50	–	35	–	30	ns	Fig. 16-4
Address hold time	t_{AH}	20	–	15	–	10	–	ns	Fig. 16-4
Address strobe delay time	t_{ASD}	–	50	–	35	–	30	ns	Fig. 16-4
Write strobe delay time	t_{WSD}	–	50	–	35	–	30	ns	Fig. 16-4
Strobe delay time	t_{SD}	–	50	–	35	–	30	ns	Fig. 16-4
Write strobe pulse width*	t_{WSW}	110	–	90	–	60	–	ns	Fig. 16-4
Address setup time 1*	t_{AS1}	15	–	10	–	10	–	ns	Fig. 16-4
Address setup time 2*	t_{AS2}	65	–	50	–	40	–	ns	Fig. 16-4
Read data setup time	t_{RDS}	35	–	20	–	20	–	ns	Fig. 16-4
Read data hold time*	t_{RDH}	0	–	0	–	0	–	ns	Fig. 16-4
Read data access time*	t_{ACC}	–	170	–	160	–	110	ns	Fig. 16-4
Write data delay time	t_{WDD}	–	75	–	60	–	60	ns	Fig. 16-4
Write data setup time	t_{WDS}	5	–	5	–	5	–	ns	Fig. 16-4
Write data hold time	t_{WDH}	20	–	20	–	20	–	ns	Fig. 16-4
Wait setup time	t_{WTS}	40	–	35	–	30	–	ns	Fig. 16-5
Wait hold time	t_{WTH}	10	–	10	–	10	–	ns	Fig. 16-5

Note: * Values at maximum operating frequency

Table 16-8 Control Signal Timing

Condition A: $V_{CC} = 5.0 \text{ V} \pm 10\%$, $V_{SS} = 0 \text{ V}$, $\phi = 2.0 \text{ MHz}$ to maximum operating frequency,
 $T_a = -20 \text{ to } 75^\circ\text{C}$ (regular specifications),
 $T_a = -40 \text{ to } 85^\circ\text{C}$ (wide-range specifications)

Condition B: $V_{CC} = 4.0 \text{ V to } 5.5 \text{ V}$, $V_{SS} = 0 \text{ V}$, $\phi = 2.0 \text{ MHz}$ to maximum operating frequency,
 $T_a = -20 \text{ to } 75^\circ\text{C}$ (regular specifications),
 $T_a = -40 \text{ to } 85^\circ\text{C}$ (wide-range specifications)

Condition C: $V_{CC} = 2.7 \text{ V to } 5.5 \text{ V}$, $V_{SS} = 0 \text{ V}$, $\phi = 2.0 \text{ MHz}$ to maximum operating frequency,
 $T_a = -20 \text{ to } 75^\circ\text{C}$

Item	Symbol	Condition C		Condition B		Condition A		Unit	Test Conditions
		10 MHz	10 MHz	12 MHz	12 MHz	16 MHz	16 MHz		
$\overline{\text{RES}}$ setup time	t_{RESS}	300	–	200	–	200	–	ns	Fig. 16-6
$\overline{\text{RES}}$ pulse width	t_{RESW}	10	–	10	–	10	–	t_{cyc}	Fig. 16-6
$\overline{\text{NMI}}$ setup time ($\overline{\text{NMI}}$, $\overline{\text{IRQ}}_0$ to $\overline{\text{IRQ}}_2$)	t_{NMIS}	300	–	150	–	150	–	ns	Fig. 16-7
$\overline{\text{NMI}}$ hold time ($\overline{\text{NMI}}$, $\overline{\text{IRQ}}_0$ to $\overline{\text{IRQ}}_2$)	t_{NMIH}	10	–	10	–	10	–	ns	Fig. 16-7
Interrupt pulse width for recovery from software standby mode ($\overline{\text{NMI}}$, $\overline{\text{IRQ}}_0$ to $\overline{\text{IRQ}}_2$)	t_{NMIW}	300	–	200	–	200	–	ns	Fig. 16-7
Crystal oscillator settling time (reset)	t_{OSC1}	20	–	20	–	20	–	ms	Fig. 16-8
Crystal oscillator settling time (software standby)	t_{OSC2}	8	–	8	–	8	–	ms	Fig. 16-9

• Measurement Conditions for AC Characteristics

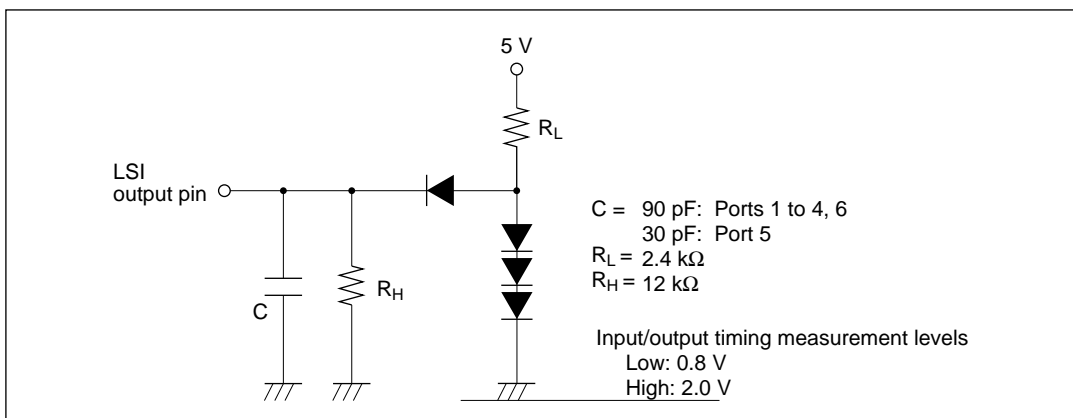

Figure 16-3 Measurement Conditions for A/C Characteristics

Table 16-9 Timing Conditions of On-Chip Supporting Modules

Condition A: $V_{CC} = 5.0\text{ V} \pm 10\%$, $V_{SS} = 0\text{ V}$, $\phi = 2.0\text{ MHz}$ to maximum operating frequency,
 $T_a = -20\text{ to }75^\circ\text{C}$ (regular specifications),
 $T_a = -40\text{ to }85^\circ\text{C}$ (wide-range specifications)

Condition B: $V_{CC} = 4.0\text{ V to }5.5\text{ V}$, $V_{SS} = 0\text{ V}$, $\phi = 2.0\text{ MHz}$ to maximum operating frequency,
 $T_a = -20\text{ to }75^\circ\text{C}$ (regular specifications),
 $T_a = -40\text{ to }85^\circ\text{C}$ (wide-range specifications)

Condition C: $V_{CC} = 2.7\text{ V to }5.5\text{ V}$, $V_{SS} = 0\text{ V}$, $\phi = 2.0\text{ MHz}$ to maximum operating frequency,
 $T_a = -20\text{ to }75^\circ\text{C}$

Item	Symbol	Condition C		Condition B		Condition A		Unit	Test Conditions	
		10 MHz		12 MHz		16 MHz				
		Min	Max	Min	Max	Min	Max			
FRT	Timer output delay time	t_{FTOD}	–	150	–	100	–	100	ns	Fig. 16-10
	Timer input setup time	t_{FTIS}	80	–	50	–	50	–	ns	Fig. 16-10
	Timer clock input setup time	t_{FTCS}	80	–	50	–	50	–	ns	Fig. 16-11
	Timer clock pulse width	t_{FTCWH} t_{FTCWL}	1.5	–	1.5	–	1.5	–	t_{cyc}	Fig. 16-11
TMR	Timer output delay time	t_{TMOD}	–	150	–	100	–	100	ns	Fig. 16-12
	Timer reset input setup time	t_{TMRS}	80	–	50	–	50	–	ns	Fig. 16-14
	Timer clock input setup time	t_{TMCS}	80	–	50	–	50	–	ns	Fig. 16-13
	Timer clock pulse width (single edge)	t_{TMCWH}	1.5	–	1.5	–	1.5	–	t_{cyc}	Fig. 16-13
	Timer clock pulse width (both edges)	t_{TMCWL}	2.5	–	2.5	–	2.5	–	t_{cyc}	Fig. 16-13
SCI	Input clock cycle	(Async) t_{Scyc}	4	–	4	–	4	–	t_{cyc}	Fig. 16-15
		(Sync) t_{Scyc}	6	–	6	–	6	–	t_{cyc}	Fig. 16-15
	Transmit data delay time (Sync)	t_{TXD}	–	200	–	100	–	100	ns	Fig. 16-15
	Receive data setup time (Sync)	t_{RXS}	150	–	100	–	100	–	ns	Fig. 16-15
	Receive data hold time (Sync)	t_{RXH}	150	–	100	–	100	–	ns	Fig. 16-15
	Input clock pulse width	t_{SCKW}	0.4	0.6	0.4	0.6	0.4	0.6	t_{Scyc}	Fig. 16-16
Ports	Output data delay time	t_{PWD}	–	150	–	100	–	100	ns	Fig. 16-17
	Input data setup time	t_{PRS}	80	–	50	–	50	–	ns	Fig. 16-17
	Input data hold time	t_{PRH}	80	–	50	–	50	–	ns	Fig. 16-17

Table 16-10 External Clock Output Delay Timing

Conditions: $V_{CC} = 2.7\text{ V to }5.5\text{ V}$, $AV_{CC} = 2.7\text{ V to }5.5\text{ V}$,
 $V_{SS} = AV_{SS} = 0\text{ V}$, $T_a = -40\text{ to }+85^\circ\text{C}$

Item	Symbol	Condition		Unit	Test Conditions
		Min	Max		
External clock output delay time	t_{DEXT}	500	—	μs	Fig. 16-18

Note: * t_{DEXT} includes \overline{RES} pulse width t_{RESW} (10 tcyc).

16.2.3 A/D Converter Characteristics

Table 16-11 lists the characteristics of the on-chip A/D converter.

Table 16-11 A/D Converter Characteristics

- Condition A: $V_{CC} = 5.0\text{ V} \pm 10\%$, $V_{CCB} = 5.0\text{ V} \pm 10\%$, $AV_{CC} = 5.0\text{ V} \pm 10\%$,
 $AV_{ref} = 4.5\text{ V}$ to AV_{CC} , $V_{SS} = 0\text{ V}$, $\phi = 2.0\text{ MHz}$ to maximum operating frequency,
 $T_a = -20$ to $+75^\circ\text{C}$ (regular specifications), $T_a = -40$ to $+85^\circ\text{C}$ (wide-range specifications)
- Condition B: $V_{CC} = 4.0\text{ V}$ to 5.5 V , $V_{CCB} = 4.0$ to 5.5 V , $AV_{CC} = 4.0$ to 5.5 V ,
 $AV_{ref} = 4.0$ to AV_{CC} , $V_{SS} = 0\text{ V}$, $\phi = 2.0\text{ MHz}$ to maximum operating frequency,
 $T_a = -20$ to $+75^\circ\text{C}$ (regular specifications), $T_a = -40$ to $+85^\circ\text{C}$ (wide-range specifications)
- Condition C: $V_{CC} = 2.7$ to 5.5 V , $V_{CCB} = 2.7$ to 5.5 V , $AV_{CC} = 2.7$ to 5.5 V ,
 $AV_{ref} = 2.7\text{ V}$ to AV_{CC} , $V_{SS} = AV_{SS} = 0\text{ V}$, $\phi = 2.0\text{ MHz}$ to maximum operating frequency,
 $T_a = -20$ to $+75^\circ\text{C}$

Item	Condition C			Condition B			Condition A			Unit
	10 MHz			12 MHz			16 MHz			
	Min	Typ	Max	Min	Typ	Max	Min	Typ	Max	
Resolution	10	10	10	10	10	10	10	10	10	Bits
Conversion time (single mode)*	—	—	13.4	—	—	11.2	—	—	8.4	μs
Analog input capacitance	—	—	20	—	—	20	—	—	20	pF
Allowable signal source impedance	—	—	5	—	—	10	—	—	10	$\text{k}\Omega$
Nonlinearity error	—	—	± 6.0	—	—	± 3.0	—	—	± 3.0	LSB
Offset error	—	—	± 4.0	—	—	± 3.5	—	—	± 3.5	LSB
Full-scale error	—	—	± 4.0	—	—	± 3.5	—	—	± 3.5	LSB
Quantizing error	—	—	± 0.5	—	—	± 0.5	—	—	± 0.5	LSB
Absolute accuracy	—	—	± 8.0	—	—	± 4.0	—	—	± 4.0	LSB

Note: * Values at maximum operating frequency

(2) Basic Bus Cycle (with 1 Wait State) in Expanded Modes

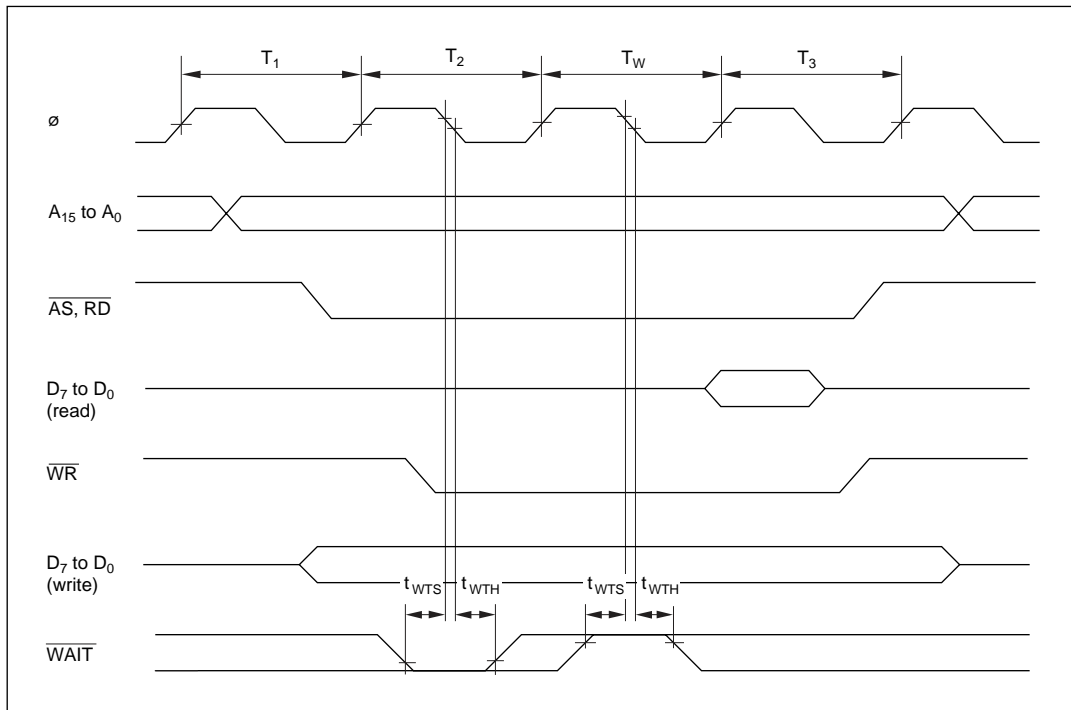

Figure 16-5 Basic Bus Cycle (with 1 Wait State) in Expanded Modes

16.3.2 Control Signal Timing

(1) Reset Input Timing

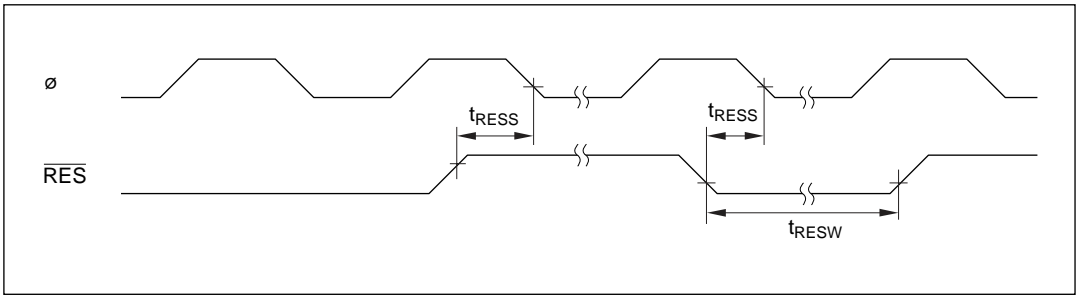

Figure 16-6 Reset Input Timing

(2) Interrupt Input Timing

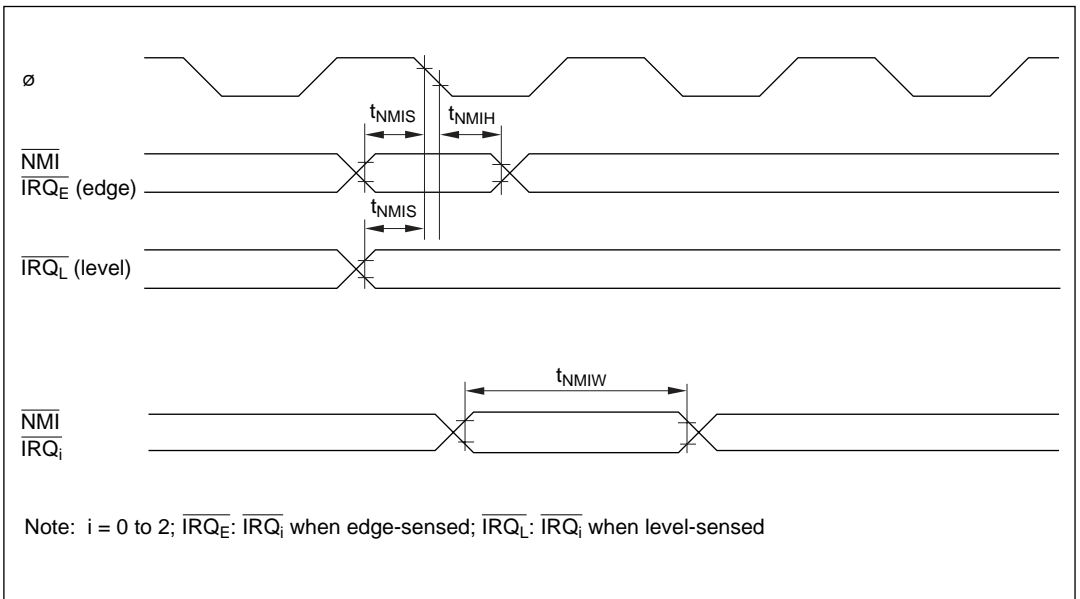

Figure 16-7 Interrupt Input Timing

(3) Clock Settling Timing

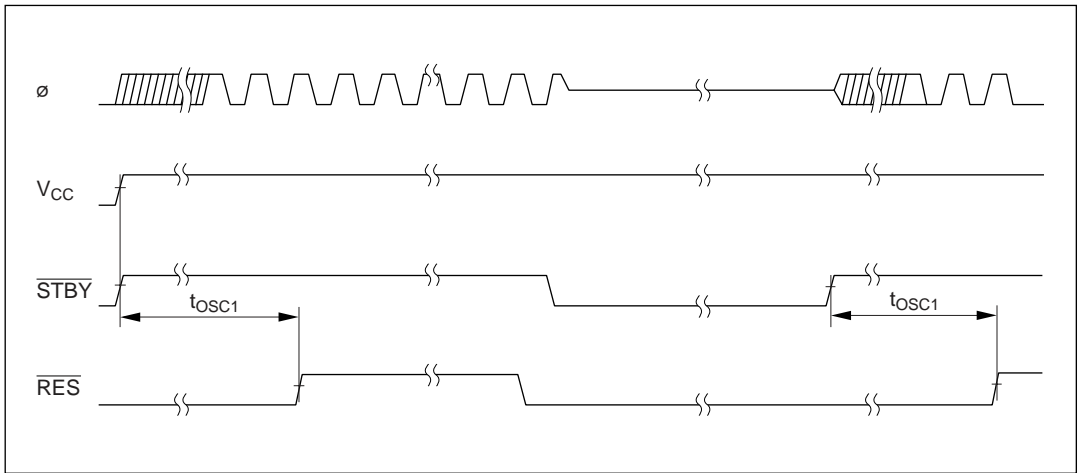

Figure 16-8 Clock Settling Timing

(4) Clock Settling Timing for Recovery from Software Standby Mode

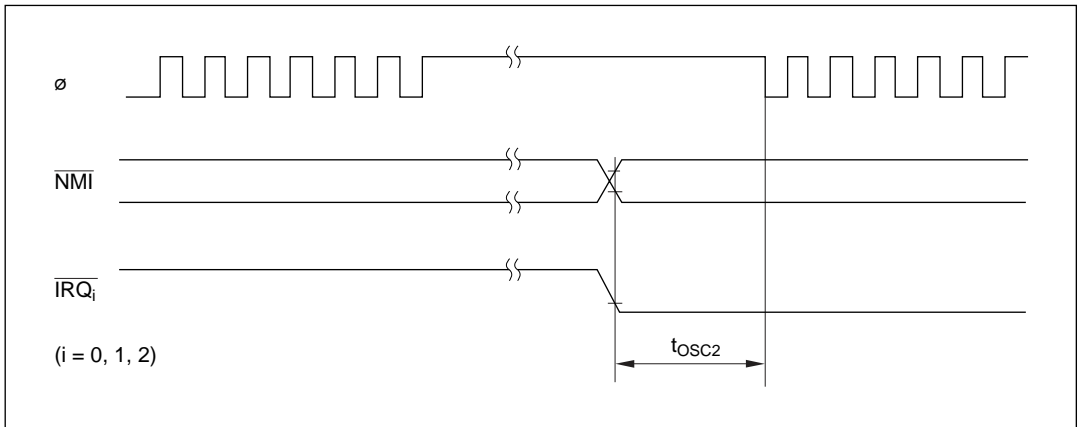

Figure 16-9 Clock Settling Timing for Recovery from Software Standby Mode

16.3.3 16-Bit Free-Running Timer Timing

(1) Free-Running Timer Input/Output Timing

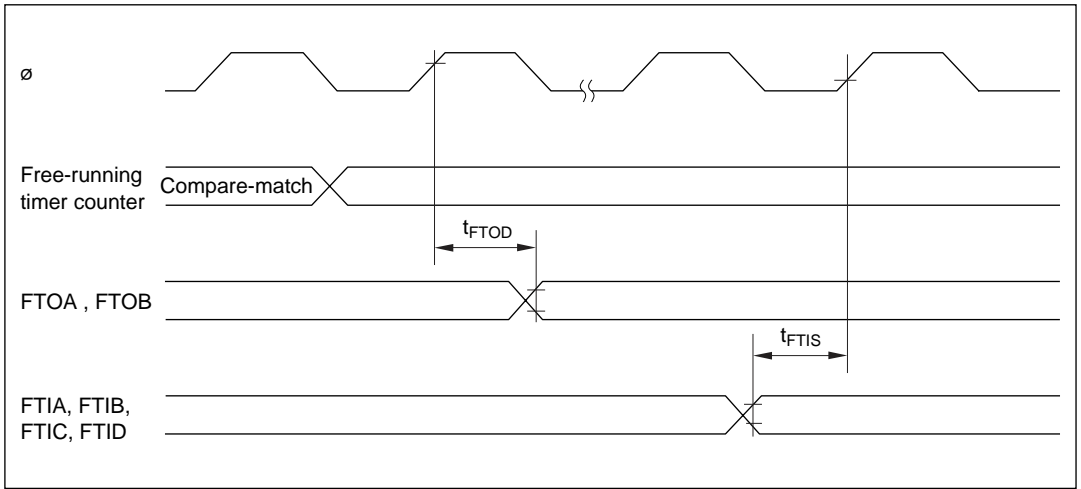

Figure 16-10 Free-Running Timer Input/Output Timing

(2) External Clock Input Timing for Free-Running Timer

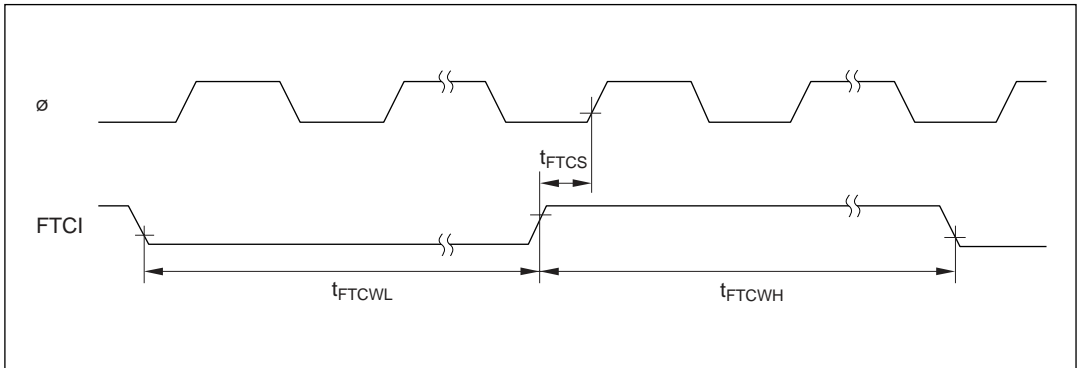

Figure 16-11 External Clock Input Timing for Free-Running Timer

16.3.4 8-Bit Timer Timing

(1) 8-Bit Timer Output Timing

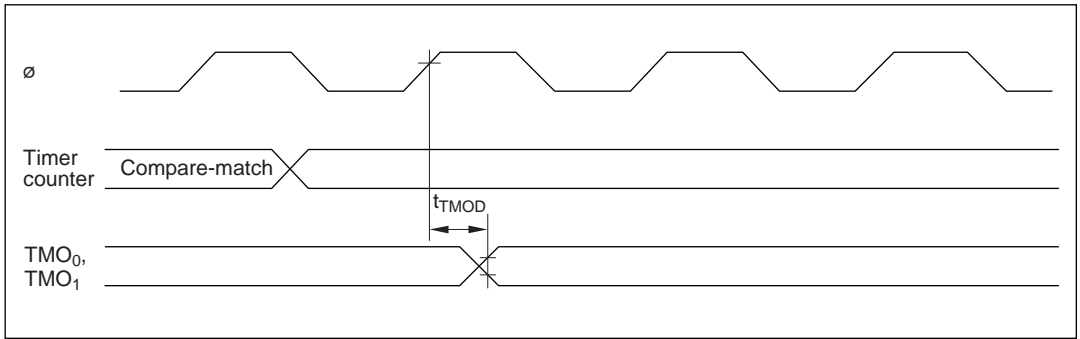

Figure 16-12 8-Bit Timer Output Timing

(2) 8-Bit Timer Clock Input Timing

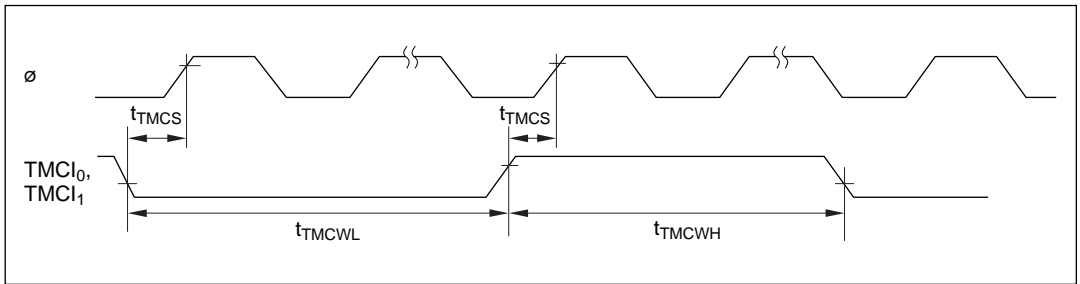

Figure 16-13 8-Bit Timer Clock Input Timing

(3) 8-Bit Timer Reset Input Timing

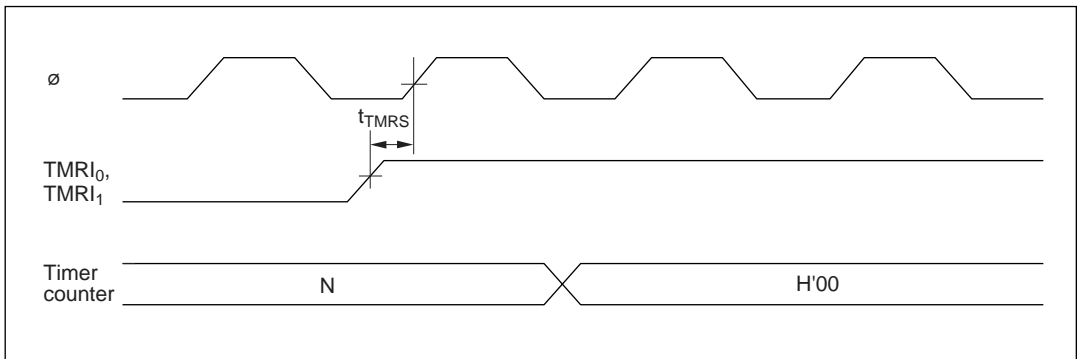

Figure 16-14 8-Bit Timer Reset Input Timing

16.3.5 Serial Communication Interface Timing

(1) SCI Input/Output Timing

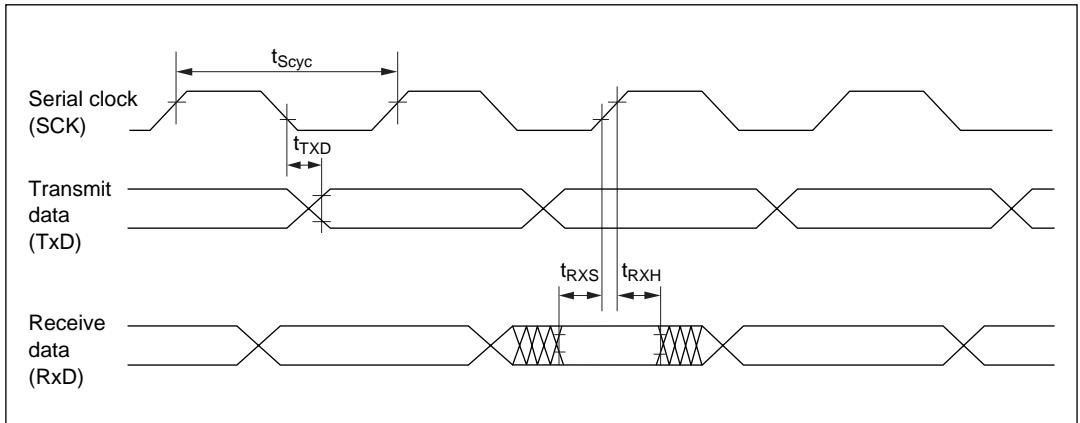

Figure 16-15 SCI Input/Output Timing (Synchronous Mode)

(2) SCI Input Clock Timing

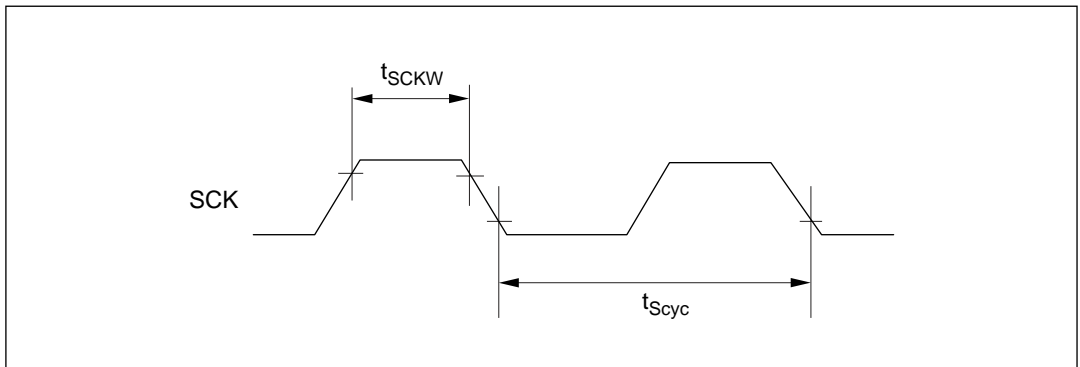

Figure 16-16 SCI Input Clock Timing

16.3.6 I/O Port Timing

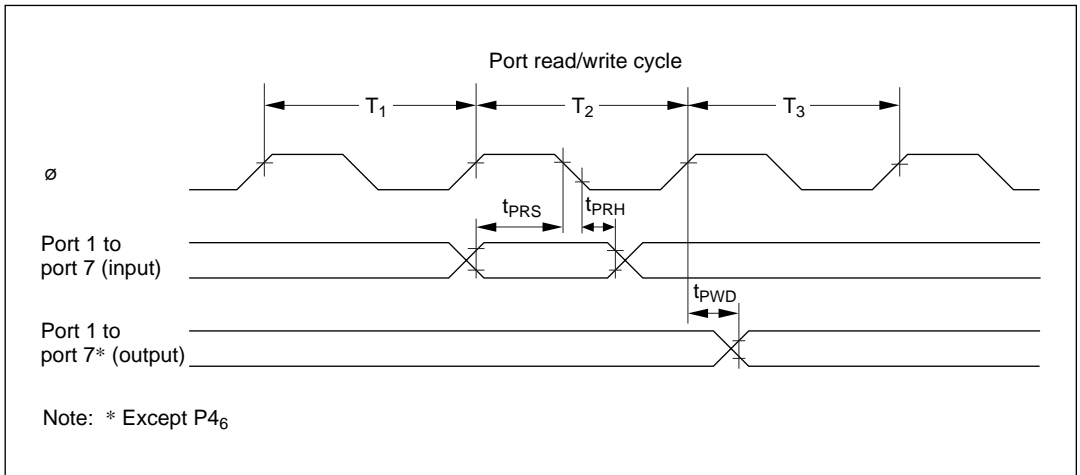

Figure 16-17 I/O Port Input/Output Timing

16.3.7 External Clock Output Timing

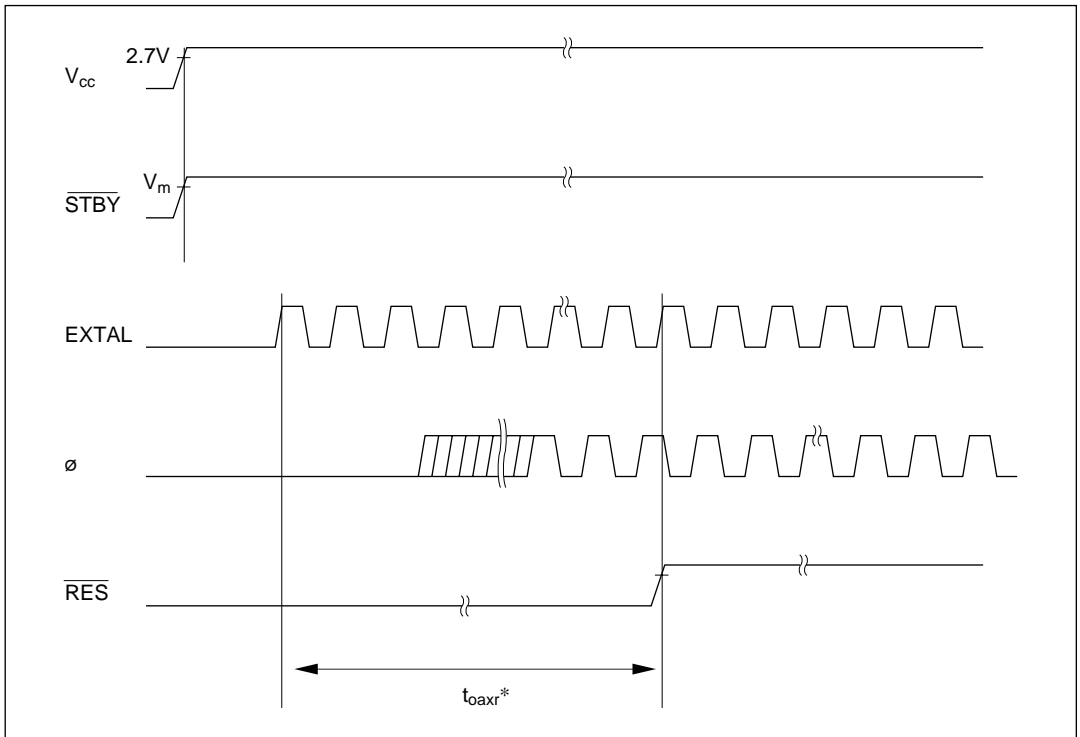

Figure 16-18 External Clock Output Delay Timing

Note: * t_{DEXT} includes \overline{RES} pulse width t_{RESW} (10 tcyc).

Appendix A CPU Instruction Set

A.1 Instruction Set List

Operation Notation

Rd8/16	General register (destination) (8 or 16 bits)
Rs8/16	General register (source) (8 or 16 bits)
Rn8/16	General register (8 or 16 bits)
CCR	Condition code register
N	N (negative) flag in CCR
Z	Z (zero) flag in CCR
V	V (overflow) flag in CCR
C	C (carry) flag in CCR
PC	Program counter
SP	Stack pointer
#xx:3/8/16	Immediate data (3, 8, or 16 bits)
d:8/16	Displacement (8 or 16 bits)
@aa:8/16	Absolute address (8 or 16 bits)
+	Addition
−	Subtraction
×	Multiplication
÷	Division
^	AND logical
∨	OR logical
⊕	Exclusive OR logical
→	Move
—	Not

Condition Code Notation

↑	Modified according to the instruction result
*	Undetermined (unpredictable)
0	Always cleared to 0
—	Not affected by the instruction result

Table A-1 Instruction Set

Mnemonic	Operand Size	Operation	Addressing Mode/ Instruction Length								Condition Code						No. of States		
			#xx: 8/16	Rn	@Rn	@ (d:16, Rn)	@ -Rn/@Rn+	@aa: 8/16	@ (d:8, PC)	@ @aa	Implied	I	H	N	Z	V		C	
MOV.B #xx:8, Rd	B	#xx:8 → Rd8	2										—	—	↑	↓	0	—	2
MOV.B Rs, Rd	B	Rs8 → Rd8		2									—	—	↑	↓	0	—	2
MOV.B @Rs, Rd	B	@Rs16 → Rd8			2								—	—	↑	↓	0	—	4
MOV.B @(d:16, Rs), Rd	B	@(d:16, Rs16) → Rd8				4							—	—	↑	↓	0	—	6
MOV.B @Rs+, Rd	B	@Rs16 → Rd8 Rs16+1 → Rs16					2						—	—	↑	↓	0	—	6
MOV.B @aa:8, Rd	B	@aa:8 → Rd8						2					—	—	↑	↓	0	—	4
MOV.B @aa:16, Rd	B	@aa:16 → Rd8							4				—	—	↑	↓	0	—	6
MOV.B Rs, @Rd	B	Rs8 → @Rd16			2								—	—	↑	↓	0	—	4
MOV.B Rs, @(d:16, Rd)	B	Rs8 → @(d:16, Rd16)				4							—	—	↑	↓	0	—	6
MOV.B Rs, @-Rd	B	Rd16-1 → Rd16 Rs8 → @Rd16					2						—	—	↑	↓	0	—	6
MOV.B Rs, @aa:8	B	Rs8 → @aa:8						2					—	—	↑	↓	0	—	4
MOV.B Rs, @aa:16	B	Rs8 → @aa:16							4				—	—	↑	↓	0	—	6
MOV.W #xx:16, Rd	W	#xx:16 → Rd16	4										—	—	↑	↓	0	—	4
MOV.W Rs, Rd	W	Rs16 → Rd16		2									—	—	↑	↓	0	—	2
MOV.W @Rs, Rd	W	@Rs16 → Rd16			2								—	—	↑	↓	0	—	4
MOV.W @(d:16, Rs), Rd	W	@(d:16, Rs16) → Rd16				4							—	—	↑	↓	0	—	6
MOV.W @Rs+, Rd	W	@Rs16 → Rd16 Rs16+2 → Rs16					2						—	—	↑	↓	0	—	6
MOV.W @aa:16, Rd	W	@aa:16 → Rd16						4					—	—	↑	↓	0	—	6
MOV.W Rs, @Rd	W	Rs16 → @Rd16			2								—	—	↑	↓	0	—	4
MOV.W Rs, @(d:16, Rd)	W	Rs16 → @(d:16, Rd16)				4							—	—	↑	↓	0	—	6
MOV.W Rs, @-Rd	W	Rd16-2 → Rd16 Rs16 → @Rd16					2						—	—	↑	↓	0	—	6
MOV.W Rs, @aa:16	W	Rs16 → @aa:16							4				—	—	↑	↓	0	—	6
POP Rd	W	@SP → Rd16 SP+2 → SP					2						—	—	↑	↓	0	—	6
PUSH Rs	W	SP-2 → SP Rs16 → @SP					2						—	—	↑	↓	0	—	6

Table A-1 Instruction Set (cont)

Mnemonic	Operand Size	Operation	Addressing Mode/ Instruction Length								Condition Code						No. of States	
			#xx: 8/16	Rn	@Rn	@ (d:16, Rn)	@-Rn/@Rn+	@aa: 8/16	@ (d:8, PC)	@ @aa	Implied	I	H	N	Z	V		C
MOVFPPE @aa:16, Rd	B	Not supported																
MOVTPE Rs, @aa:16	B	Not supported																
EEPMOV	—	if R4L≠0 then Repeat @R5 → @R6 R5+1 → R5 R6+1 → R6 R4L-1 → R4L Until R4L=0 else next								4	—	—	—	—	—	④		
ADD.B #xx:8, Rd	B	Rd8+#xx:8 → Rd8	2								—	↑	↑	↑	↑	↑	2	
ADD.B Rs, Rd	B	Rd8+Rs8 → Rd8		2							—	↑	↑	↑	↑	↑	2	
ADD.W Rs, Rd	W	Rd16+Rs16 → Rd16		2							—	①	↑	↑	↑	↑	2	
ADDX.B #xx:8, Rd	B	Rd8+#xx:8 +C → Rd8	2								—	↑	↑	②	↑	↑	2	
ADDX.B Rs, Rd	B	Rd8+Rs8 +C → Rd8		2							—	↑	↑	②	↑	↑	2	
ADDS.W #1, Rd	W	Rd16+1 → Rd16		2							—	—	—	—	—	—	2	
ADDS.W #2, Rd	W	Rd16+2 → Rd16		2							—	—	—	—	—	—	2	
INC.B Rd	B	Rd8+1 → Rd8		2							—	—	↑	↑	↑	—	2	
DAA.B Rd	B	Rd8 decimal adjust → Rd8		2							—	*	↑	↑	*	③	2	
SUB.B Rs, Rd	B	Rd8-Rs8 → Rd8		2							—	↑	↑	↑	↑	↑	2	
SUB.W Rs, Rd	W	Rd16-Rs16 → Rd16		2							—	①	↑	↑	↑	↑	2	
SUBX.B #xx:8, Rd	B	Rd8-#xx:8 -C → Rd8	2								—	↑	↑	②	↑	↑	2	
SUBX.B Rs, Rd	B	Rd8-Rs8 -C → Rd8		2							—	↑	↑	②	↑	↑	2	
SUBS.W #1, Rd	W	Rd16-1 → Rd16		2							—	—	—	—	—	—	2	
SUBS.W #2, Rd	W	Rd16-2 → Rd16		2							—	—	—	—	—	—	2	
DEC.B Rd	B	Rd8-1 → Rd8		2							—	—	↑	↑	↑	—	2	
DAS.B Rd	B	Rd8 decimal adjust → Rd8		2							—	*	↑	↑	*	—	2	
NEG.B Rd	B	0-Rd8 → Rd8		2							—	↑	↑	↑	↑	↑	2	
CMP.B #xx:8, Rd	B	Rd8-#xx:8	2								—	↑	↑	↑	↑	↑	2	
CMP.B Rs, Rd	B	Rd8-Rs8		2							—	↑	↑	↑	↑	↑	2	
CMP.W Rs, Rd	W	Rd16-Rs16		2							—	①	↑	↑	↑	↑	2	

Table A-1 Instruction Set (cont)

Mnemonic	Operand Size	Operation	Addressing Mode/ Instruction Length								Condition Code						No. of States	
			#xx: 8/16	Rn	@Rn	@ (d:16, Rn)	@ -Rn/@Rn+	@aa: 8/16	@ (d:8, PC)	@ @aa	Implied	I	H	N	Z	V		C
MULXU.B Rs, Rd	B	$Rd8 \times Rs8 \rightarrow Rd16$		2													14	
DIVXU.B Rs, Rd	B	$Rd16 \div Rs8 \rightarrow Rd16$ (RdH: remainder, RdL: quotient)		2									⑥	⑦			14	
AND.B #xx:8, Rd	B	$Rd8 \wedge \#xx:8 \rightarrow Rd8$	2										↕	↕	0		2	
AND.B Rs, Rd	B	$Rd8 \wedge Rs8 \rightarrow Rd8$	2										↕	↕	0		2	
OR.B #xx:8, Rd	B	$Rd8 \vee \#xx:8 \rightarrow Rd8$	2										↕	↕	0		2	
OR.B Rs, Rd	B	$Rd8 \vee Rs8 \rightarrow Rd8$	2										↕	↕	0		2	
XOR.B #xx:8, Rd	B	$Rd8 \oplus \#xx:8 \rightarrow Rd8$	2										↕	↕	0		2	
XOR.B Rs, Rd	B	$Rd8 \oplus Rs8 \rightarrow Rd8$	2										↕	↕	0		2	
NOT.B Rd	B	$\overline{Rd8} \rightarrow Rd8$	2										↕	↕	0		2	
SHAL.B Rd	B		2										↕	↕	↕	↕	2	
SHAR.B Rd	B		2										↕	↕	0	↕	2	
SHLL.B Rd	B		2										↕	↕	0	↕	2	
SHLR.B Rd	B		2										0	↕	0	↕	2	
ROTXL.B Rd	B		2										↕	↕	0	↕	2	
ROTXR.B Rd	B		2										↕	↕	0	↕	2	

Table A-1 Instruction Set (cont)

Mnemonic	Operand Size	Operation	Addressing Mode/ Instruction Length								Condition Code						No. of States								
			Branching Condition	#xx: 8/16	Rn	@Rn	@ (d:16, Rn)	@-Rn/@Rn+	@aa: 8/16	@ (d:8, PC)	@@aa	Implied	Condition Code												
													I	H	N	Z		V	C						
BIOR #xx:3, @aa:8	B	$C \vee (\#xx:3 \text{ of } @aa:8) \rightarrow C$							4										↑	6					
BXOR #xx:3, Rd	B	$C \oplus (\#xx:3 \text{ of } Rd8) \rightarrow C$			2															↑	2				
BXOR #xx:3, @Rd	B	$C \oplus (\#xx:3 \text{ of } @Rd16) \rightarrow C$				4															↑	6			
BXOR #xx:3, @aa:8	B	$C \oplus (\#xx:3 \text{ of } @aa:8) \rightarrow C$							4												↑	6			
BIXOR #xx:3, Rd	B	$C \oplus (\#xx:3 \text{ of } Rd8) \rightarrow C$			2																	↑	2		
BIXOR #xx:3, @Rd	B	$C \oplus (\#xx:3 \text{ of } @Rd16) \rightarrow C$				4																	↑	6	
BIXOR #xx:3, @aa:8	B	$C \oplus (\#xx:3 \text{ of } @aa:8) \rightarrow C$							4														↑	6	
BRA d:8 (BT d:8)	—	$PC \leftarrow PC+d:8$								2														4	
BRN d:8 (BF d:8)	—	$PC \leftarrow PC+2$								2														4	
BHI d:8	—	If condition is true then PC ← PC+d:8 else next;	C ∨ Z = 0							2														4	
BLS d:8	—		C ∨ Z = 1								2														4
BCC d:8 (BHS d:8)	—		C = 0								2														4
BCS d:8 (BLO d:8)	—		C = 1								2														4
BNE d:8	—		Z = 0								2														4
BEQ d:8	—		Z = 1								2														4
BVC d:8	—		V = 0								2														4
BVS d:8	—		V = 1								2														4
BPL d:8	—		N = 0								2														4
BMI d:8	—		N = 1								2														4
BGE d:8	—		N ⊕ V = 0								2														4
BLT d:8	—		N ⊕ V = 1								2														4
BGT d:8	—		Z ∨ (N ⊕ V) = 0								2														4
BLE d:8	—		Z ∨ (N ⊕ V) = 1								2														4
JMP @Rn	—		$PC \leftarrow Rn16$				2																		4
JMP @aa:16	—		$PC \leftarrow aa:16$								4														6
JMP @@aa:8	—	$PC \leftarrow @@aa:8$												2										8	
BSR d:8	—	SP-2 → SP PC → @SP PC ← PC+d:8								2														6	

Table A-1 Instruction Set (cont)

Mnemonic	Operand Size	Operation	Addressing Mode/ Instruction Length (bytes)								Condition Code						No. of States	
			#xx: 8/16	Rn	@Rn	@(d:16, Rn)	@-Rn/@Rn+	@aa: 8/16	@(d:8, PC)	@@aa	Implied	I	H	N	Z	V		C
			JSR @Rn	—	SP-2 → SP PC → @SP PC ← Rn16			2										
JSR @aa:16	—	SP-2 → SP PC → @SP PC ← aa:16						4									8	
JSR @@aa:8		SP-2 → SP PC → @SP PC ← @aa:8								2							8	
RTS	—	PC ← @SP SP+2 → SP									2						8	
RTE	—	CCR ← @SP SP+2 → SP PC ← @SP SP+2 → SP									2	↑	↑	↑	↑	↑	↑	10
SLEEP	—	Transit to sleep mode.									2	—	—	—	—	—	—	2
LDC #xx:8, CCR	B	#xx:8 → CCR	2									↑	↑	↑	↑	↑	↑	2
LDC Rs, CCR	B	Rs8 → CCR		2								↑	↑	↑	↑	↑	↑	2
STC CCR, Rd	B	CCR → Rd8		2								—	—	—	—	—	—	2
ANDC #xx:8, CCR	B	CCR ∧ #xx:8 → CCR	2									↑	↑	↑	↑	↑	↑	2
ORC #xx:8, CCR	B	CCR ∨ #xx:8 → CCR	2									↑	↑	↑	↑	↑	↑	2
XORC #xx:8, CCR	B	CCR ⊕ #xx:8 → CCR	2									↑	↑	↑	↑	↑	↑	2
NOP	—	PC ← PC+2									2	—	—	—	—	—	—	2

Notes: The number of states is the number of states required for execution when the instruction and its operands are located in on-chip memory.

- ① Set to 1 when there is a carry or borrow from bit 11; otherwise cleared to 0.
- ② If the result is zero, the previous value of the flag is retained; otherwise the flag is cleared to 0.
- ③ Set to 1 if decimal adjustment produces a carry; otherwise cleared to 0.
- ④ The number of states required for execution is 4n+8 (n = value of R4L).
- ⑤ These instructions are not supported by the H8/3437 Series.
- ⑥ Set to 1 if the divisor is negative; otherwise cleared to 0.
- ⑦ Set to 1 if the divisor is zero; otherwise cleared to 0.

A.2 Operation Code Map

Table A-2 is a map of the operation codes contained in the first byte of the instruction code (bits 15 to 8 of the first instruction word).

Some pairs of instructions have identical first bytes. These instructions are differentiated by the first bit of the second byte (bit 7 of the first instruction word).



Instruction when first bit of byte 2 (bit 7 of first instruction word) is 0.

Instruction when first bit of byte 2 (bit 7 of first instruction word) is 1.

Table A-2 Operation Code Map

Low High	0	1	2	3	4	5	6	7	8	9	A	B	C	D	E	F
0	NOP	SLEEP	STC	LDC	ORC	XORC	ANDC	LDC	ADD	INC	ADDS	MOV	ADDX	DAA		
1	SHLL SHAL	SHLR SHAR	ROTXL ROTL	ROTXR ROTR	OR	XOR	AND	NOT NEG	SUB	DEC	SUBS	CMP	SUBX	DAS		
2	MOV															
3	MOV															
4	BRA ^{*2}	BRN ^{*2}	BHI	BLS	BCC ^{*2}	BCS ^{*2}	BNE	BEQ	BVC	BVS	BPL	BMI	BGE	BLT	BGT	BLE
5	MULXU	DIVXU			RTS	BSR	RTE				JMP				JSR	
6	BSET	BINOT	BCLR	BTS				BST								
7					BOR	BXOR	BAND	BISL	BILD	MOV		EEMOV				Bit manipulation instructions
8	ADD															
9	ADDX															
A	CMP															
B	SUBX															
C	OR															
D	XOR															
E	AND															
F	MOV															

Notes: 1. The MOVFPE and MOVTPPE instructions are identical to MOV instructions in the first byte and first bit of the second byte (bits 15 to 7 of the instruction word).
 The PUSH and POP instructions are identical in machine language to MOV instructions.
 2. The BT, BF, BHS, and BLO instructions are identical in machine language to BRA, BRN, BCC, and BCS, respectively.

A.3 Number of States Required for Execution

The tables below can be used to calculate the number of states required for instruction execution. Table A-3 indicates the number of states required for each cycle (instruction fetch, branch address read, stack operation, byte data access, word data access, internal operation). Table A-4 indicates the number of cycles of each type occurring in each instruction. The total number of states required for execution of an instruction can be calculated from these two tables as follows:

$$\text{Execution states} = I \times S_I + J \times S_J + K \times S_K + L \times S_L + M \times S_M + N \times S_N$$

Examples: Mode 1 (on-chip ROM disabled), stack located in external memory, 1 wait state inserted in external memory access.

1. BSET #0, @FFC7

From table A-4: $I = L = 2, \quad J = K = M = N = 0$

From table A-3: $S_I = 8, \quad S_L = 3$

Number of states required for execution: $2 \times 8 + 2 \times 3 = 22$

2. JSR @@30

From table A-4: $I = 2, \quad J = K = 1, \quad L = M = N = 0$

From table A-3: $S_I = S_J = S_K = 8$

Number of states required for execution: $2 \times 8 + 1 \times 8 + 1 \times 8 = 32$

Table A-3. Number of States Taken by Each Cycle in Instruction Execution

Execution Status (Instruction Cycle)		Access location		
		On-Chip Memory	On-Chip Reg. Field	External Memory
Instruction fetch	S_I	2	6	$6 + 2m$
Branch address read	S_J			
Stack operation	S_K			
Byte data access	S_L		3	$3 + m$
Word data access	S_M		6	$6 + 2m$
Internal operation	S_N	1	1	1

Notes: m: Number of wait states inserted in access to external device.

Table A-4 Number of Cycles in Each Instruction

Instruction	Mnemonic	Instruction	Branch	Stack	Byte Data	Word Data	Internal
		Fetch I	Addr. Read J	Operation K	Access L	Access M	Operation N
ADD	ADD.B #xx:8, Rd	1					
	ADD.B Rs, Rd	1					
	ADD.W Rs, Rd	1					
ADDS	ADDS.W #1/2, Rd	1					
ADDX	ADDX.B #xx:8, Rd	1					
	ADDX.B Rs, Rd	1					
AND	AND.B #xx:8, Rd	1					
	AND.B Rs, Rd	1					
ANDC	ANDC #xx:8, CCR	1					
BAND	BAND #xx:3, Rd	1					
	BAND #xx:3, @Rd	2			1		
	BAND #xx:3, @aa:8	2			1		
Bcc	BRA d:8 (BT d:8)	2					
	BRN d:8 (BF d:8)	2					
	BHI d:8	2					
	BLS d:8	2					
	BCC d:8 (BHS d:8)	2					
	BCS d:8 (BLO d:8)	2					
	BNE d:8	2					
	BEQ d:8	2					
	BVC d:8	2					
	BVS d:8	2					
	BPL d:8	2					
	BMI d:8	2					
	BGE d:8	2					
	BLT d:8	2					
BGT d:8	2						
BLE d:8	2						
BCLR	BCLR #xx:3, Rd	1					
	BCLR #xx:3, @Rd	2			2		
	BCLR #xx:3, @aa:8	2			2		
	BCLR Rn, Rd	1					
	BCLR Rn, @Rd	2			2		
	BCLR Rn, @aa:8	2			2		

Note: All values left blank are zero.

Table A-4 Number of Cycles in Each Instruction (cont)

Instruction	Mnemonic	Instruction	Branch	Stack	Byte Data	Word Data	Internal
		Fetch	Addr. Read	Operation	Access	Access	Operation
		I	J	K	L	M	N
BIAND	BIAND #xx:3, Rd	1					
	BIAND #xx:3, @Rd	2			1		
	BIAND #xx:3, @aa:8	2			1		
BILD	BILD #xx:3, Rd	1					
	BILD #xx:3, @Rd	2			1		
	BILD #xx:3, @aa:8	2			1		
BIOR	BIOR #xx:3, Rd	1					
	BIOR #xx:3, @Rd	2			1		
	BIOR #xx:3, @aa:8	2			1		
BIST	BIST #xx:3, Rd	1					
	BIST #xx:3, @Rd	2			2		
	BIST #xx:3, @aa:8	2			2		
BIXOR	BIXOR #xx:3, Rd	1					
	BIXOR #xx:3, @Rd	2			1		
	BIXOR #xx:3, @aa:8	2			1		
BLD	BLD #xx:3, Rd	1					
	BLD #xx:3, @Rd	2			1		
	BLD #xx:3, @aa:8	2			1		
BNOT	BNOT #xx:3, Rd	1					
	BNOT #xx:3, @Rd	2			2		
	BNOT #xx:3, @aa:8	2			2		
	BNOT Rn, Rd	1					
	BNOT Rn, @Rd	2			2		
	BNOT Rn, @aa:8	2			2		
BOR	BOR #xx:3, Rd	1					
	BOR #xx:3, @Rd	2			1		
	BOR #xx:3, @aa:8	2			1		
BSET	BSET #xx:3, Rd	1					
	BSET #xx:3, @Rd	2			2		
	BSET #xx:3, @aa:8	2			2		
	BSET Rn, Rd	1					
	BSET Rn, @Rd	2			2		
	BSET Rn, @aa:8	2			2		

Note: All values left blank are zero.

Table A-4 Number of Cycles in Each Instruction (cont)

Instruction	Mnemonic	Instruction	Branch	Stack	Byte Data	Word Data	Internal
		Fetch	Addr. Read	Operation	Access	Access	Operation
		I	J	K	L	M	N
BSR	BSR d:8	2		1			
BST	BST #xx:3, Rd	1					
	BST #xx:3, @Rd	2			2		
	BST #xx:3, @aa:8	2			2		
BTST	BTST #xx:3, Rd	1					
	BTST #xx:3, @Rd	2			1		
	BTST #xx:3, @aa:8	2			1		
	BTST Rn, Rd	1					
	BTST Rn, @Rd	2			1		
	BTST Rn, @aa:8	2			1		
BXOR	BXOR #xx:3, Rd	1					
	BXOR #xx:3, @Rd	2			1		
	BXOR #xx:3, @aa:8	2			1		
CMP	CMP.B #xx:8, Rd	1					
	CMP.B Rs, Rd	1					
	CMP.W Rs, Rd	1					
DAA	DAA.B Rd	1					
DAS	DAS.B Rd	1					
DEC	DEC.B Rd	1					
DIVXU	DIVXU.B Rs, Rd	1					12
EEPMOV	EEPMOV	2			2n+2*		1
INC	INC.B Rd	1					
JMP	JMP @Rn	2					
	JMP @aa:16	2					2
	JMP @@aa:8	2	1				2
JSR	JSR @Rn	2		1			
	JSR @aa:16	2		1			2
	JSR @@aa:8	2	1	1			
LDC	LDC #xx:8, CCR	1					
	LDC Rs, CCR	1					
MOV	MOV.B #xx:8, Rd	1					
	MOV.B Rs, Rd	1					
	MOV.B @Rs, Rd	1			1		
	MOV.B @(d:16,Rs), Rd	2			1		

Notes: All values left blank are zero.

* n: Initial value in R4L. Source and destination are accessed n + 1 times each.

Table A-4 Number of Cycles in Each Instruction (cont)

Instruction	Mnemonic	Instruction	Branch	Stack	Byte Data	Word Data	Internal
		Fetch	Addr. Read	Operation	Access	Access	Operation
		I	J	K	L	M	N
MOV	MOV.B @Rs+, Rd	1			1		2
	MOV.B @aa:8, Rd	1			1		
	MOV.B @aa:16, Rd	2			1		
	MOV.B Rs, @Rd	1			1		
	MOV.B Rs, @(d:16, Rd)	2			1		
	MOV.B Rs, @-Rd	1			1		2
	MOV.B Rs, @aa:8	1			1		
	MOV.B Rs, @aa:16	2			1		
	MOV.W #xx:16, Rd	2					
	MOV.W Rs, Rd	1					
	MOV.W @Rs, Rd	1				1	
	MOV.W @(d:16, Rs), Rd	2				1	
	MOV.W @Rs+, Rd	1				1	2
	MOV.W @aa:16, Rd	2				1	
	MOV.W Rs, @Rd	1				1	
	MOV.W Rs, @(d:16, Rd)	2				1	
	MOV.W Rs, @-Rd	1				1	2
	MOV.W Rs, @aa:16	2				1	
MOVFPPE	MOVFPPE @aa:16, Rd	Not supported					
MOVTPE	MOVTPE.Rs, @aa:16	Not supported					
MULXU	MULXU.Rs, Rd	1					12
NEG	NEG.B Rd	1					
NOP	NOP	1					
NOT	NOT.B Rd	1					
OR	OR.B #xx:8, Rd	1					
	OR.B Rs, Rd	1					
ORC	ORC #xx:8, CCR	1					
POP	POP Rd	1			1		2
PUSH	PUSH Rd	1			1		2
ROTL	ROTL.B Rd	1					
ROTR	ROTR.B Rd	1					
ROTXL	ROTXL.B Rd	1					
ROTXR	ROTXR.B Rd	1					
RTE	RTE	2		2			2
RTS	RTS	2		1			2

Note: All values left blank are zero.

Table A-4 Number of Cycles in Each Instruction (cont)

Instruction	Mnemonic	Instruction	Branch	Stack	Byte Data	Word Data	Internal
		Fetch	Addr. Read	Operation	Access	Access	Operation
		I	J	K	L	M	N
SHAL	SHAL.B Rd	1					
SHAR	SHAR.B Rd	1					
SHLL	SHLL.B Rd	1					
SHLR	SHLR.B Rd	1					
SLEEP	SLEEP	1					
STC	STC CCR, Rd	1					
SUB	SUB.B Rs, Rd	1					
	SUB.W Rs, Rd	1					
SUBS	SUBS.W #1/2, Rd	1					
SUBX	SUBX.B #xx:8, Rd	1					
	SUBX.B Rs, Rd	1					
XOR	XOR.B #xx:8, Rd	1					
	XOR.B Rs, Rd	1					
XORC	XORC #xx:8, CCR	1					

Note: All values left blank are zero.

Appendix B Internal I/O Register

B.1 Addresses

Addr. (Last Byte)	Register Name	Bit Names								Module
		Bit 7	Bit 6	Bit 5	Bit 4	Bit 3	Bit 2	Bit 1	Bit 0	
H'80										External
H'81										addresses
H'82										(in expand-
H'83										ed modes)
H'84										
H'85										
H'86										
H'87										
H'88	—	—	—	—	—	—	—	—	—	—
H'89	—	—	—	—	—	—	—	—	—	
H'8A	—	—	—	—	—	—	—	—	—	
H'8B	—	—	—	—	—	—	—	—	—	
H'8C	—	—	—	—	—	—	—	—	—	
H'8D	—	—	—	—	—	—	—	—	—	
H'8E	—	—	—	—	—	—	—	—	—	
H'8F	—	—	—	—	—	—	—	—	—	
H'90	TIER	ICIAE	ICIBE	ICICE	ICIDE	OCIAE	OCIBE	OVIE	—	FRT
H'91	TCSR	ICFA	ICFB	ICFC	ICFD	OCFA	OCFB	OVF	CCLRA	
H'92	FRCH									
H'93	FRCL									
H'94	OCRAH									
	OCRBH									
H'95	OCRAL									
	OCRBL									
H'96	TCR	IEDGA	IEDGB	IEDGC	IEDGD	BUFEA	BUFEB	CKS1	CKS0	
H'97	TOCR	—	—	—	OCRS	OEA	OEB	OLVLA	OLVLB	
H'98	ICRAH									
H'99	ICRAL									
H'9A	ICRBH									
H'9B	ICRBL									
H'9C	ICRCH									
H'9D	ICRCL									
H'9E	ICRDH									
H'9F	ICRDL									

Notes: FRT: Free-running timer

(Continued on next page)

(Continued from previous page)

Addr. (Last Byte)	Register Name	Bit Names								Module
		Bit 7	Bit 6	Bit 5	Bit 4	Bit 3	Bit 2	Bit 1	Bit 0	
H'A0	—	—	—	—	—	—	—	—	—	—
H'A1	—	—	—	—	—	—	—	—	—	—
H'A2	—	—	—	—	—	—	—	—	—	—
H'A3	—	—	—	—	—	—	—	—	—	—
H'A4	—	—	—	—	—	—	—	—	—	—
H'A5	—	—	—	—	—	—	—	—	—	—
H'A6	—	—	—	—	—	—	—	—	—	—
H'A7	—	—	—	—	—	—	—	—	—	—
H'A8	TCSR/TCNT OVF	WT/IT	TME	—	RST/NMI	CKS2	CKS1	CKS0	—	WDT
H'A9	TCNT	—	—	—	—	—	—	—	—	—
H'AA	—	—	—	—	—	—	—	—	—	—
H'AB	—	—	—	—	—	—	—	—	—	—
H'AC	P1PCR	P1 ₇ PCR	P1 ₆ PCR	P1 ₅ PCR	P1 ₄ PCR	P1 ₃ PCR	P1 ₂ PCR	P1 ₁ PCR	P1 ₀ PCR	Port 1
H'AD	P2PCR	P2 ₇ PCR	P2 ₆ PCR	P2 ₅ PCR	P2 ₄ PCR	P2 ₃ PCR	P2 ₂ PCR	P2 ₁ PCR	P2 ₀ PCR	Port 2
H'AE	P3PCR	P3 ₇ PCR	P3 ₆ PCR	P3 ₅ PCR	P3 ₄ PCR	P3 ₃ PCR	P3 ₂ PCR	P3 ₁ PCR	P3 ₀ PCR	Port 3
H'AF	—	—	—	—	—	—	—	—	—	—
H'B0	P1DDR	P1 ₇ DDR	P1 ₆ DDR	P1 ₅ DDR	P1 ₄ DDR	P1 ₃ DDR	P1 ₂ DDR	P1 ₁ DDR	P1 ₀ DDR	Port 1
H'B1	P2DDR	P2 ₇ DDR	P2 ₆ DDR	P2 ₅ DDR	P2 ₄ DDR	P2 ₃ DDR	P2 ₂ DDR	P2 ₁ DDR	P2 ₀ DDR	Port 2
H'B2	P1DR	P1 ₇	P1 ₆	P1 ₅	P1 ₄	P1 ₃	P1 ₂	P1 ₁	P1 ₀	Port 1
H'B3	P2DR	P2 ₇	P2 ₆	P2 ₅	P2 ₄	P2 ₃	P2 ₂	P2 ₁	P2 ₀	Port 2
H'B4	P3DDR	P3 ₇ DDR	P3 ₆ DDR	P3 ₅ DDR	P3 ₄ DDR	P3 ₃ DDR	P3 ₂ DDR	P3 ₁ DDR	P3 ₀ DDR	Port 3
H'B5	P4DDR	P4 ₇ DDR	P4 ₆ DDR	P4 ₅ DDR	P4 ₄ DDR	P4 ₃ DDR	P4 ₂ DDR	P4 ₁ DDR	P4 ₀ DDR	Port 4
H'B6	P3DR	P3 ₇	P3 ₆	P3 ₅	P3 ₄	P3 ₃	P3 ₂	P3 ₁	P3 ₀	Port 3
H'B7	P4DR	P4 ₇	P4 ₆	P4 ₅	P4 ₄	P4 ₃	P4 ₂	P4 ₁	P4 ₀	Port 4
H'B8	P5DDR	—	—	—	—	—	P5 ₂ DDR	P5 ₁ DDR	P5 ₀ DDR	Port 5
H'B9	P6DDR	P6 ₇ DDR	P6 ₆ DDR	P6 ₅ DDR	P6 ₄ DDR	P6 ₃ DDR	P6 ₂ DDR	P6 ₁ DDR	P6 ₀ DDR	Port 6
H'BA	P5DR	—	—	—	—	—	P5 ₂	P5 ₁	P5 ₀	Port 5
H'BB	P6DR	P6 ₇	P6 ₆	P6 ₅	P6 ₄	P6 ₃	P6 ₂	P6 ₁	P6 ₀	Port 6

Notes: WDT: Watchdog timer

(Continued on next page)

(Continued from preceding page)

Addr. (Last Byte)	Register Name	Bit Names								Module	
		Bit 7	Bit 6	Bit 5	Bit 4	Bit 3	Bit 2	Bit 1	Bit 0		
H'BC	—	—	—	—	—	—	—	—	—	—	
H'BD	—	—	—	—	—	—	—	—	—	—	
H'BE	P7PIN	P7 ₇	P7 ₆	P7 ₅	P7 ₄	P7 ₃	P7 ₂	P7 ₁	P7 ₀	Port 7	
H'BF	—	—	—	—	—	—	—	—	—	—	
H'C0	—	—	—	—	—	—	—	—	—	—	
H'C1	—	—	—	—	—	—	—	—	—	—	
H'C2	WSCR	—	—	CKDBL	—	WMS1	WMS0	WC1	WC0	System control	
H'C3	STCR	—	—	—	—	—	MPE	ICKS1	ICKS0		
H'C4	SYSCR	SSBY	STS2	STS1	STS0	XRST	NMIEG	—	RAME		
H'C5	MDCR	—	—	—	—	—	—	MDS1	MDS0		
H'C6	ISCR	—	—	—	—	—	IRQ2SC	IRQ1SC	IRQ0SC		
H'C7	IER	—	—	—	—	—	IRQ2E	IRQ1E	IRQ0E		
H'C8	TCR	CMIEB	CMIEA	OVIE	CCLR1	CCLR0	CKS2	CKS1	CKS0		TMR0
H'C9	TCSR	CMFB	CMFA	OVF	—	OS3	OS2	OS1	OS0		
H'CA	TCORA										
H'CB	TCORB										
H'CC	TCNT										
H'CD	—	—	—	—	—	—	—	—	—		
H'CE	—	—	—	—	—	—	—	—	—		
H'CF	—	—	—	—	—	—	—	—	—		
H'D0	TCR	CMIEB	CMIEA	OVIE	CCLR1	CCLR0	CKS2	CKS1	CKS0	TMR1	
H'D1	TCSR	CMFB	CMFA	OVF	—	OS3	OS2	OS1	OS0		
H'D2	TCORA										
H'D3	TCORB										
H'D4	TCNT										
H'D5	—	—	—	—	—	—	—	—	—		
H'D6	—	—	—	—	—	—	—	—	—		
H'D7	—	—	—	—	—	—	—	—	—		

Notes: TMR0: 8-bit timer channel 0
TMR1: 8-bit timer channel 1

(Continued on next page)

(Continued from preceding page)

Addr. (Last Byte)	Register Name	Bit Names								Module
		Bit 7	Bit 6	Bit 5	Bit 4	Bit 3	Bit 2	Bit 1	Bit 0	
H'D8	SMR	C/ \bar{A}	CHR	PE	O/ \bar{E}	STOP	MP	CKS1	CKS0	SCI
H'D9	BRR									
H'DA	SCR	TIE	RIE	TE	RE	MPIE	TEIE	CKE1	CKE0	
H'DB	TDR									
H'DC	SSR	TDRE	RDRF	ORER	FER	PER	TEND	MPB	MPBT	
H'DD	RDR									
H'DE	—	—	—	—	—	—	—	—	—	
H'DF	—	—	—	—	—	—	—	—	—	
H'E0	ADDRAH	AD9	AD8	AD7	AD6	AD5	AD4	AD3	AD2	A/D
H'E1	ADDRAL	AD1	AD0	—	—	—	—	—	—	
H'E2	ADDRBH	AD9	AD8	AD7	AD6	AD5	AD4	AD3	AD2	
H'E3	ADDRBL	AD1	AD0	—	—	—	—	—	—	
H'E4	ADDRCH	AD9	AD8	AD7	AD6	AD5	AD4	AD3	AD2	
H'E5	ADDRCL	AD1	AD0	—	—	—	—	—	—	
H'E6	ADDRDH	AD9	AD8	AD7	AD6	AD5	AD4	AD3	AD2	
H'E7	ADDRDL	AD1	AD0	—	—	—	—	—	—	
H'E8	ADCSR	ADF	ADIE	ADST	SCAN	CKS	CH2	CH1	CH0	
H'E9	ADCR	TRGE	—	—	—	—	—	—	—	
H'EA	—	—	—	—	—	—	—	—	—	
H'EB	—	—	—	—	—	—	—	—	—	
H'EC	—	—	—	—	—	—	—	—	—	—
H'ED	—	—	—	—	—	—	—	—	—	
H'EE	—	—	—	—	—	—	—	—	—	
H'EF	—	—	—	—	—	—	—	—	—	

Notes: A/D: Analog-to-digital converter
 SCI: Serial communication interface

(Continued on next page)

(Continued from preceding page)

Addr. (Last Byte)	Register Name	Bit Names								Module
		Bit 7	Bit 6	Bit 5	Bit 4	Bit 3	Bit 2	Bit 1	Bit 0	
H'F0	—	—	—	—	—	—	—	—	—	—
H'F1	—	—	—	—	—	—	—	—	—	—
H'F2	—	—	—	—	—	—	—	—	—	—
H'F3	—	—	—	—	—	—	—	—	—	—
H'F4	—	—	—	—	—	—	—	—	—	—
H'F5	—	—	—	—	—	—	—	—	—	—
H'F6	—	—	—	—	—	—	—	—	—	—
H'F7	—	—	—	—	—	—	—	—	—	—
H'F8	—	—	—	—	—	—	—	—	—	—
H'F9	—	—	—	—	—	—	—	—	—	—
H'FA	—	—	—	—	—	—	—	—	—	—
H'FB	—	—	—	—	—	—	—	—	—	—
H'FC	—	—	—	—	—	—	—	—	—	—
H'FD	—	—	—	—	—	—	—	—	—	—
H'FE	—	—	—	—	—	—	—	—	—	—
H'FF	—	—	—	—	—	—	—	—	—	—

B.2 Function Descriptions

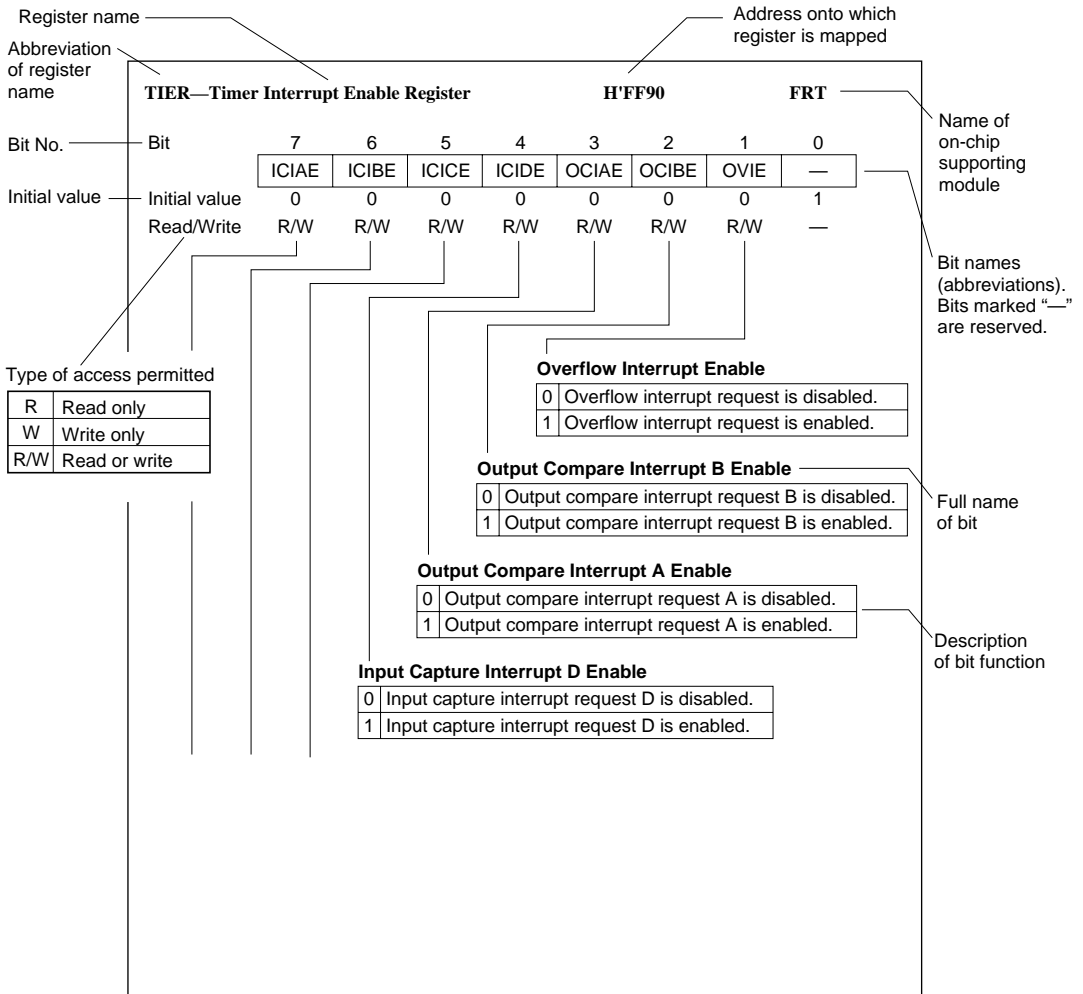

Bit	7	6	5	4	3	2	1	0
	ICIAE	ICIBE	ICICE	ICIDE	OCIAE	OCIBE	OVIE	—
Initial value	0	0	0	0	0	0	0	1
Read/Write	R/W	R/W	R/W	R/W	R/W	R/W	R/W	—

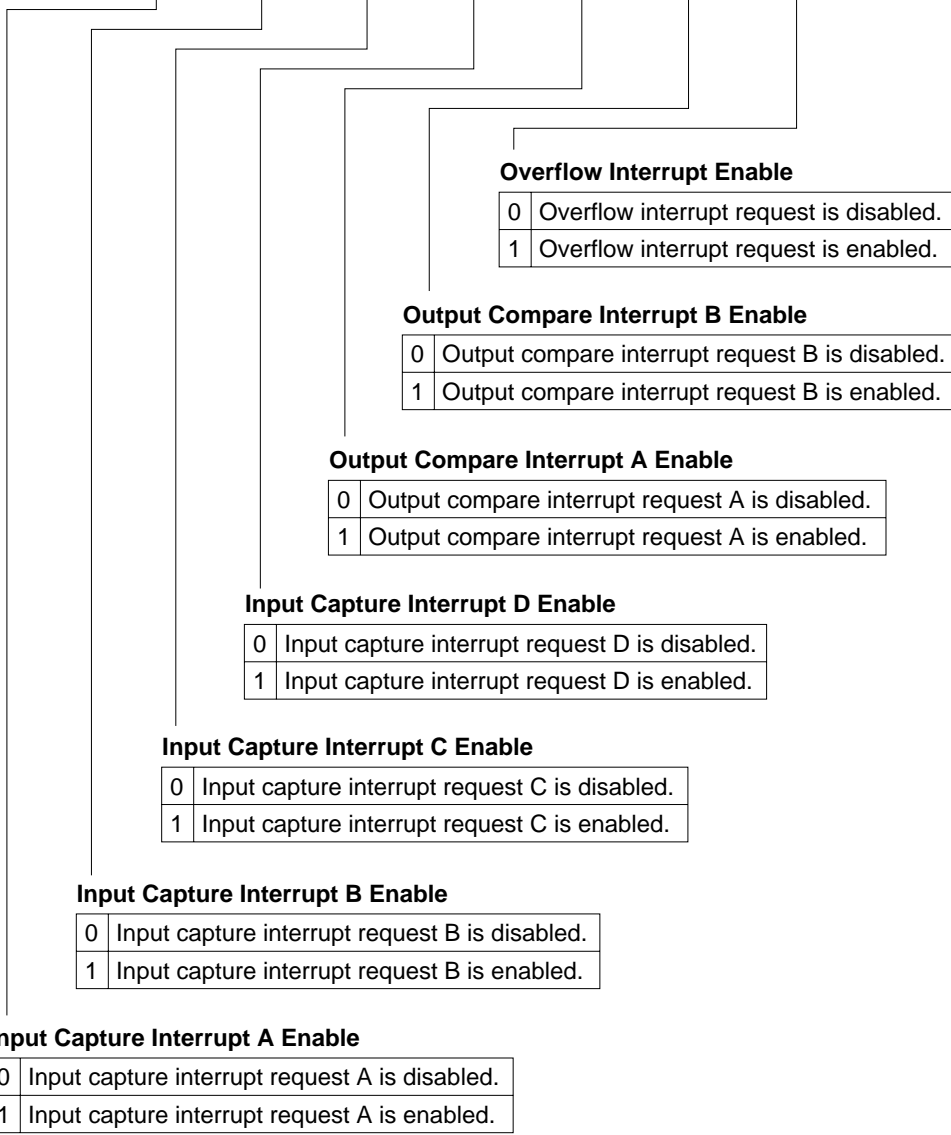

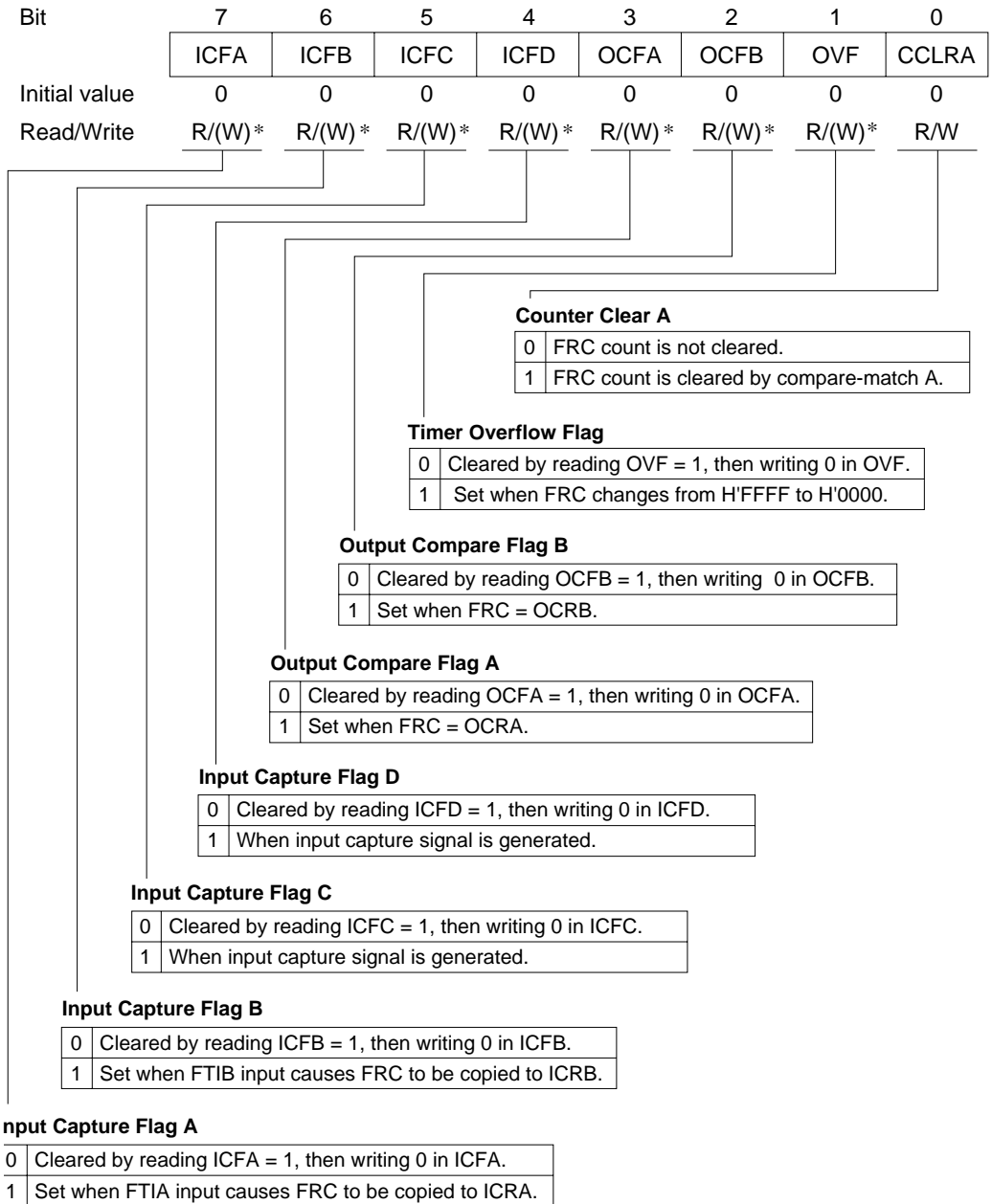

Note: * Software can write a 0 in bits 7 to 1 to clear the flags, but cannot write a 1 in these bits.

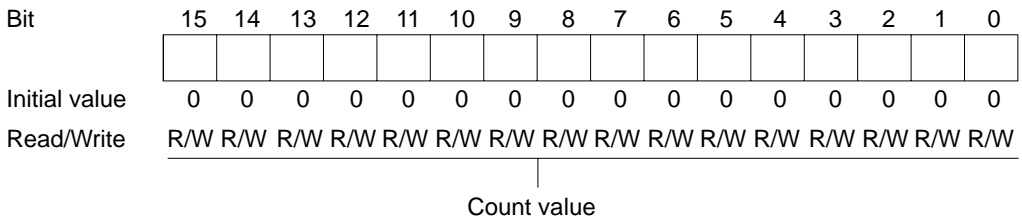

OCRA (H and L)—Output Compare Register A

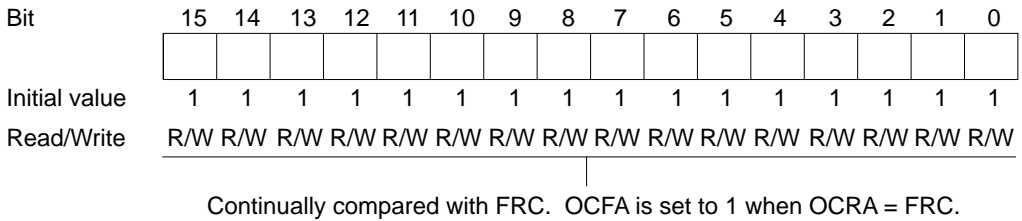

OCRB (H and L)—Output Compare Register B

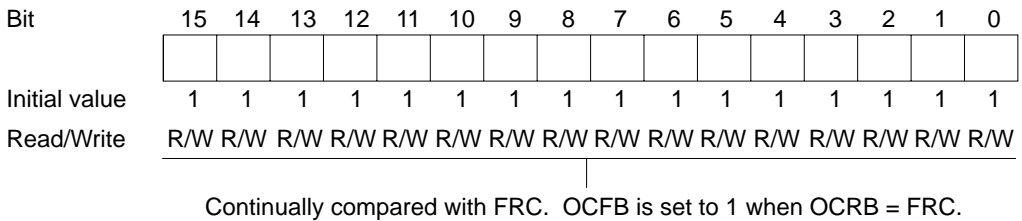

Bit	7	6	5	4	3	2	1	0
	IEDGA	IEDGB	IEDGC	IEDGD	BUFEA	BUFEB	CKS1	CKS0
Initial value	0	0	0	0	0	0	0	0
Read/Write	R/W	R/W	R/W	R/W	R/W	R/W	R/W	R/W

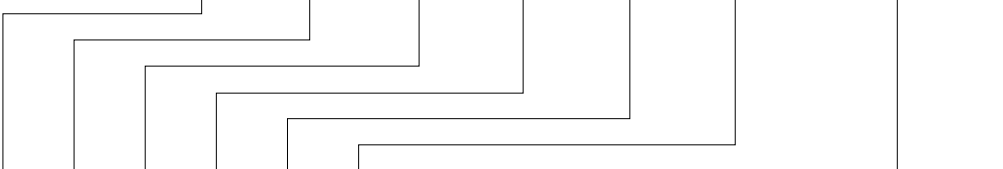

Clock Select

0	0	Internal clock source: $\phi_P/2$
0	1	Internal clock source: $\phi_P/8$
1	0	Internal clock source: $\phi_P/32$
1	1	External clock source: counted on rising edge

Buffer Enable B

0	ICRD is used for input capture D.
1	ICRD is buffer register for input capture B.

Buffer Enable A

0	ICRC is used for input capture C.
1	ICRC is buffer register for input capture A.

Input Edge Select D

0	Falling edge of FTID is valid.
1	Rising edge of FTID is valid.

Input Edge Select C

0	Falling edge of FTIC is valid.
1	Rising edge of FTIC is valid.

Input Edge Select B

0	Falling edge of FTIB is valid.
1	Rising edge of FTIB is valid.

Input Edge Select A

0	Falling edge of FTIA is valid.
1	Rising edge of FTIA is valid.

Bit	7	6	5	4	3	2	1	0
	—	—	—	OCRS	OEA	OEB	OLVLA	OLVLB
Initial value	1	1	1	0	0	0	0	0
Read/Write	—	—	—	R/W	R/W	R/W	R/W	R/W

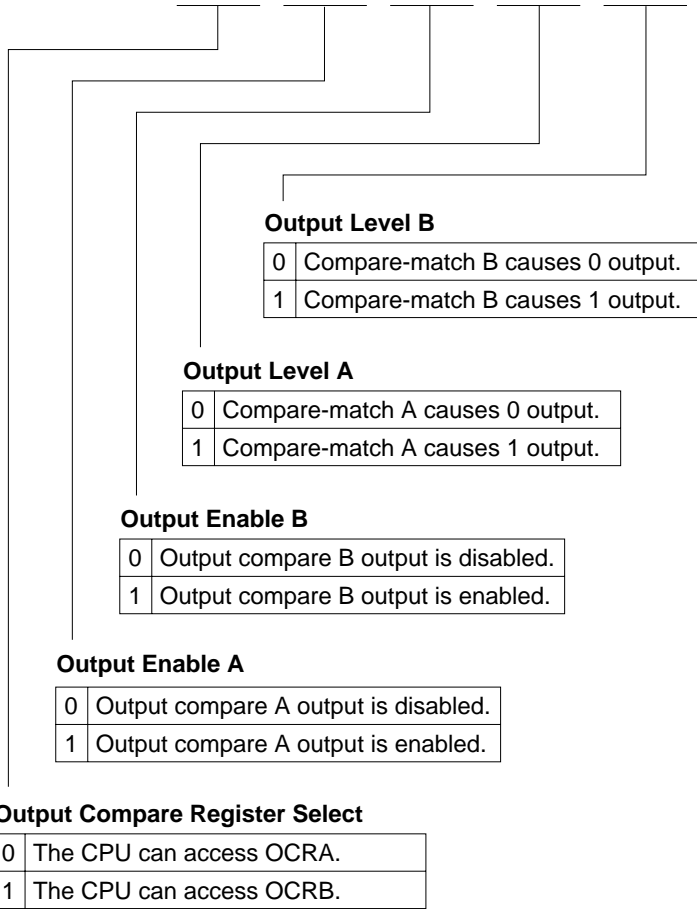

Bit	15	14	13	12	11	10	9	8	7	6	5	4	3	2	1	0
Initial value	0	0	0	0	0	0	0	0	0	0	0	0	0	0	0	0
Read/Write	R	R	R	R	R	R	R	R	R	R	R	R	R	R	R	R

Contains FRC count captured on FTIA input.

ICRB (H and L)—Input Capture Register B**H'FF9A, H'FF9B****FRT**

Bit	15	14	13	12	11	10	9	8	7	6	5	4	3	2	1	0
Initial value	0	0	0	0	0	0	0	0	0	0	0	0	0	0	0	0
Read/Write	R	R	R	R	R	R	R	R	R	R	R	R	R	R	R	R

|
Contains FRC count captured on FTIB input.

ICRC (H and L)—Input Capture Register C**H'FF9C, H'FF9D****FRT**

Bit	15	14	13	12	11	10	9	8	7	6	5	4	3	2	1	0
Initial value	0	0	0	0	0	0	0	0	0	0	0	0	0	0	0	0
Read/Write	R	R	R	R	R	R	R	R	R	R	R	R	R	R	R	R

|
Contains FRC count captured on FTIC input, or old ICRA value in buffer mode.

ICRD (H and L)—Input Capture Register D**H'FF9E, H'FF9F****FRT**

Bit	15	14	13	12	11	10	9	8	7	6	5	4	3	2	1	0
Initial value	0	0	0	0	0	0	0	0	0	0	0	0	0	0	0	0
Read/Write	R	R	R	R	R	R	R	R	R	R	R	R	R	R	R	R

|
Contains FRC count captured on FTID input, or old ICRB value in buffer mode.

Bit	7	6	5	4	3	2	1	0
	OVF	WT/IT	TME	—	RST/NMI	CKS2	CKS1	CKS0
Initial value	0	0	0	1	0	0	0	0
Read/Write	R/(W)*	R/W	R/W	—	R/W	R/W	R/W	R/W

Clock Select 2 to 0

0	0	0	$\phi_p/2$
	1	0	$\phi_p/32$
1	0	0	$\phi_p/64$
	1	0	$\phi_p/128$
1	0	0	$\phi_p/256$
		1	$\phi_p/512$
	1	0	$\phi_p/2048$
		1	$\phi_p/4096$

Reset or NMI Select

0	NMI function enabled
1	Reset function enabled

Timer Enable

0	Timer disabled: TCNT is initialized to H'00 and stopped
1	Timer enabled: TCNT runs; CPU interrupts can be requested

Timer Mode Select

0	Interval timer mode (interval timer interrupt request)
1	Watchdog timer mode (generates reset or NMI signal)

Overflow Flag

0	Cleared by reading OVF = 1, then writing 1 in OVF
1	Set when TCNT changes from H'FF to H'00

Note: * Only 0 can be written, to clear the flag.

Bit	7	6	5	4	3	2	1	0
Initial value	0	0	0	0	0	0	0	0
Read/Write	R/W	R/W	R/W	R/W	R/W	R/W	R/W	R/W

|
Count value

P1PCR—Port 1 Input Pull-Up Control Register

Bit	7	6	5	4	3	2	1	0
Initial value	0	0	0	0	0	0	0	0
Read/Write	R/W	R/W	R/W	R/W	R/W	R/W	R/W	R/W

Port 1 Input Pull-Up Control

0	Input pull-up transistor is off.
1	Input pull-up transistor is on.

P2PCR—Port 2 Input Pull-Up Control Register

Bit	7	6	5	4	3	2	1	0
Initial value	0	0	0	0	0	0	0	0
Read/Write	R/W	R/W	R/W	R/W	R/W	R/W	R/W	R/W

Port 2 Input Pull-Up Control

0	Input pull-up transistor is off.
1	Input pull-up transistor is on.

P3PCR—Port 3 Input Pull-Up Control Register**H'FFAE****Port 3**

Bit	7	6	5	4	3	2	1	0
	P3 ₇ PCR	P3 ₆ PCR	P3 ₅ PCR	P3 ₄ PCR	P3 ₃ PCR	P3 ₂ PCR	P3 ₁ PCR	P3 ₀ PCR
Initial value	0	0	0	0	0	0	0	0
Read/Write	R/W	R/W	R/W	R/W	R/W	R/W	R/W	R/W

Port 3 Input Pull-Up Control

0	Input pull-up transistor is off.
1	Input pull-up transistor is on.

P1DDR—Port 1 Data Direction Register**H'FFB0****Port 1**

Bit	7	6	5	4	3	2	1	0
	P1 ₇ DDR	P1 ₆ DDR	P1 ₅ DDR	P1 ₄ DDR	P1 ₃ DDR	P1 ₂ DDR	P1 ₁ DDR	P1 ₀ DDR
Mode 1								
Initial value	1	1	1	1	1	1	1	1
Read/Write	—	—	—	—	—	—	—	—
Modes 2 and 3								
Initial value	0	0	0	0	0	0	0	0
Read/Write	W	W	W	W	W	W	W	W

Port 1 Input/Output Control

0	Input port
1	Output port

P1DR—Port 1 Data Register**H'FFB2****Port 1**

Bit	7	6	5	4	3	2	1	0
	P1 ₇	P1 ₆	P1 ₅	P1 ₄	P1 ₃	P1 ₂	P1 ₁	P1 ₀
Initial value	0	0	0	0	0	0	0	0
Read/Write	R/W	R/W	R/W	R/W	R/W	R/W	R/W	R/W

P2DDR—Port 2 Data Direction Register**H'FFB1****Port 2**

Bit	7	6	5	4	3	2	1	0
	P2 ₇ DDR	P2 ₆ DDR	P2 ₅ DDR	P2 ₄ DDR	P2 ₃ DDR	P2 ₂ DDR	P2 ₁ DDR	P2 ₀ DDR

Mode 1

Initial value	1	1	1	1	1	1	1	1
Read/Write	—	—	—	—	—	—	—	—

Modes 2 and 3

Initial value	0	0	0	0	0	0	0	0
Read/Write	W	W	W	W	W	W	W	W

Port 2 Input/Output Control

0	Input port
1	Output port

P2DR—Port 2 Data Register**H'FFB3****Port 2**

Bit	7	6	5	4	3	2	1	0
	P2 ₇	P2 ₆	P2 ₅	P2 ₄	P2 ₃	P2 ₂	P2 ₁	P2 ₀

Initial value	0	0	0	0	0	0	0	0
Read/Write	R/W	R/W	R/W	R/W	R/W	R/W	R/W	R/W

P3DDR—Port 3 Data Direction Register**H'FFB4****Port 3**

Bit	7	6	5	4	3	2	1	0
	P3 ₇ DDR	P3 ₆ DDR	P3 ₅ DDR	P3 ₄ DDR	P3 ₃ DDR	P3 ₂ DDR	P3 ₁ DDR	P3 ₀ DDR

Initial value	0	0	0	0	0	0	0	0
Read/Write	W	W	W	W	W	W	W	W

Port 3 Input/Output Control

0	Input port
1	Output port

P3DR—Port 3 Data Register**H'FFB6****Port 3**

Bit	7	6	5	4	3	2	1	0
	P3 ₇	P3 ₆	P3 ₅	P3 ₄	P3 ₃	P3 ₂	P3 ₁	P3 ₀
Initial value	0	0	0	0	0	0	0	0
Read/Write	R/W	R/W	R/W	R/W	R/W	R/W	R/W	R/W

P4DDR—Port 4 Data Direction Register**H'FFB5****Port 4**

Bit	7	6	5	4	3	2	1	0
	P4 ₇ DDR	P4 ₆ DDR	P4 ₅ DDR	P4 ₄ DDR	P4 ₃ DDR	P4 ₂ DDR	P4 ₁ DDR	P4 ₀ DDR
Initial value	0	0	0	0	0	0	0	0
Read/Write	W	W	W	W	W	W	W	W

Port 4 Input/Output Control

0	Input port
1	Output port

P4DR—Port 4 Data Register**H'FFB7****Port 4**

Bit	7	6	5	4	3	2	1	0
	P4 ₇	P4 ₆	P4 ₅	P4 ₄	P4 ₃	P4 ₂	P4 ₁	P4 ₀
Initial value	0	0	0	0	0	0	0	0
Read/Write	R/W	R/W	R/W	R/W	R/W	R/W	R/W	R/W

P5DDR—Port 5 Data Direction Register**H'FFB8****Port 5**

Bit	7	6	5	4	3	2	1	0
	—	—	—	—	—	P5 ₂ DDR	P5 ₁ DDR	P5 ₀ DDR
Initial value	1	1	1	1	1	0	0	0
Read/Write	—	—	—	—	—	W	W	W

Port 5 Input/Output Control

0	Input port
1	Output port

P5DR—Port 5 Data Register**H'FFBA****Port 5**

Bit	7	6	5	4	3	2	1	0
	—	—	—	—	—	P5 ₂	P5 ₁	P5 ₀
Initial value	1	1	1	1	1	0	0	0
Read/Write	—	—	—	—	—	R/W	R/W	R/W

P6DDR—Port 6 Data Direction Register**H'FFB9****Port 6**

Bit	7	6	5	4	3	2	1	0
	P6 ₇ DDR	P6 ₆ DDR	P6 ₅ DDR	P6 ₄ DDR	P6 ₃ DDR	P6 ₂ DDR	P6 ₁ DDR	P6 ₀ DDR
Initial value	0	0	0	0	0	0	0	0
Read/Write	W	W	W	W	W	W	W	W

Port 6 Input/Output Control

0	Input port
1	Output port

P6DR—Port 6 Data Register**H'FFBB****Port 6**

Bit	7	6	5	4	3	2	1	0
	P6 ₇	P6 ₆	P6 ₅	P6 ₄	P6 ₃	P6 ₂	P6 ₁	P6 ₀
Initial value	0	0	0	0	0	0	0	0
Read/Write	R/W	R/W	R/W	R/W	R/W	R/W	R/W	R/W

P7PIN—Port 7 Input Register**H'FFBE****Port 7**

Bit	7	6	5	4	3	2	1	0
	P7 ₇	P7 ₆	P7 ₅	P7 ₄	P7 ₃	P7 ₂	P7 ₁	P7 ₀
Initial value	*	*	*	*	*	*	*	*
Read/Write	R	R	R	R	R	R	R	R

Note: * Depends on the levels of pins P7₇ to P7₀.

Bit	7	6	5	4	3	2	1	0
	—	—	CKDBL	—	WMS1	WMS0	WC1	WC0
Initial value	0	0	0	0	1	0	0	0
Read/Write	R/W	R/W	R/W	R/W	R/W	R/W	R/W	R/W

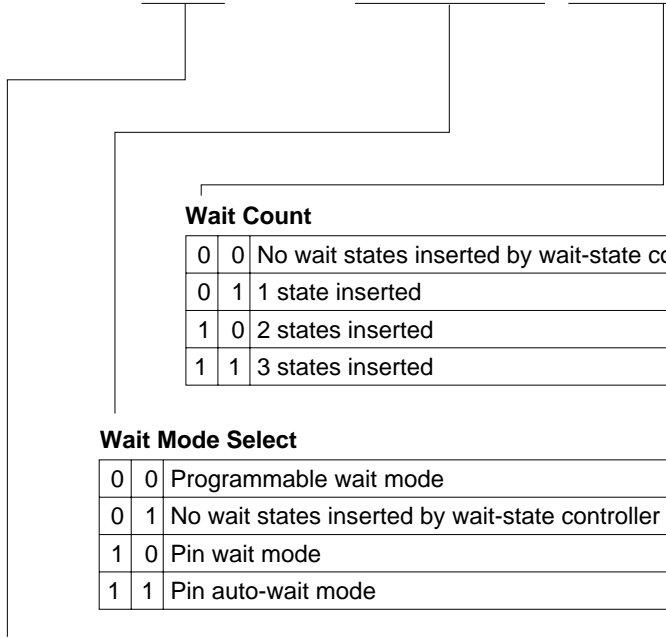

Wait Count

0	0	No wait states inserted by wait-state controller
0	1	1 state inserted
1	0	2 states inserted
1	1	3 states inserted

Wait Mode Select

0	0	Programmable wait mode
0	1	No wait states inserted by wait-state controller
1	0	Pin wait mode
1	1	Pin auto-wait mode

Clock Double

0	Supporting module clock frequency is not divided ($\phi_P = \phi$)
1	Supporting module clock frequency is divided by two ($\phi_P = \phi/2$)

Bit	7	6	5	4	3	2	1	0
	—	—	—	—	—	MPE	ICKS1	ICKS0
Initial value	1	1	1	1	1	0	0	0
Read/Write	—	—	—	—	—	R/W	R/W	R/W

Internal Clock Source Select
See TCR under TMR0 and TMR1.

Multiprocessor Enable

0	Multiprocessor communication function is disabled.
1	Multiprocessor communication function is enabled.

Bit	7	6	5	4	3	2	1	0
	SSBY	STS2	STS1	STS0	XRST	NMIEG	–	RAME
Initial value	0	0	0	0	1	0	1	1
Read/Write	R/W	R/W	R/W	R/W	R	R/W	–	R/W

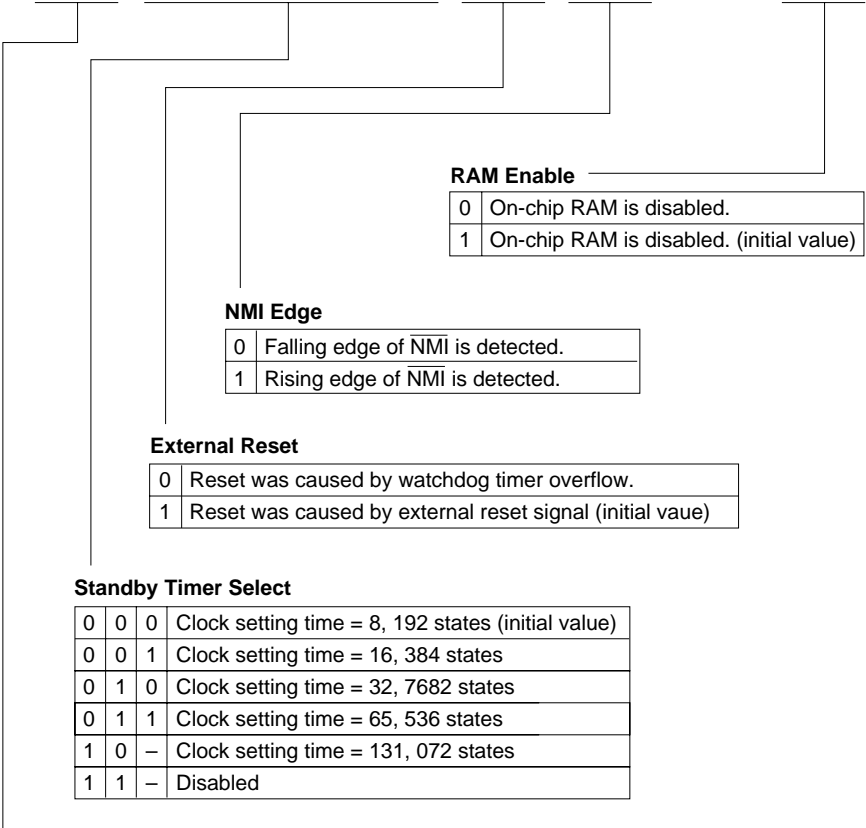

RAM Enable

0	On-chip RAM is disabled.
1	On-chip RAM is disabled. (initial value)

NMI Edge

0	Falling edge of NMI is detected.
1	Rising edge of NMI is detected.

External Reset

0	Reset was caused by watchdog timer overflow.
1	Reset was caused by external reset signal (initial vaue)

Standby Timer Select

0	0	0	Clock setting time = 8, 192 states (initial value)
0	0	1	Clock setting time = 16, 384 states
0	1	0	Clock setting time = 32, 7682 states
0	1	1	Clock setting time = 65, 536 states
1	0	–	Clock setting time = 131, 072 states
1	1	–	Disabled

Software Standby

0	SLEEP instruction causes transition to sleep mode, (initial value)
1	SLEEP instruction causes transition to software standby mode.

MDCR—Mode Control Register**H'FFC5****System Control**

Bit	7	6	5	4	3	2	1	0
	—	—	—	—	—	—	MDS1	MDS0
Initial value	1	1	1	0	0	1	*	*
Read/Write	—	—	—	—	—	—	R	R

Mode Select Bits

Value at mode pins.

Note: * Determined by inputs at pins MD₁ and MD₀.**ISCR—IRQ Sense Control Register****H'FFC6****System Control**

Bit	7	6	5	4	3	2	1	0
	—	—	—	—	—	IRQ ₂ SC	IRQ ₁ SC	IRQ ₀ SC
Initial value	1	1	1	1	1	0	0	0
Read/Write	—	—	—	—	—	R/W	R/W	R/W

IRQ₀ to IRQ₂ Sense Control

0	IRQ ₀ to IRQ ₂ are level-sensed (active low).
1	IRQ ₀ to IRQ ₂ are edge-sensed (falling edge).

IER—IRQ Enable Register**H'FFC7****System Control**

Bit	7	6	5	4	3	2	1	0
	—	—	—	—	—	IRQ ₂ E	IRQ ₁ E	IRQ ₀ E
Initial value	1	1	1	1	1	0	0	0
Read/Write	—	—	—	—	—	R/W	R/W	R/W

IRQ₀ to IRQ₂ Enable

0	IRQ ₀ to IRQ ₂ are disabled.
1	IRQ ₀ to IRQ ₂ are enabled.

Bit	7	6	5	4	3	2	1	0
	CMIEB	CMIEA	OVIE	CCLR1	CCLR0	CKS2	CKS1	CKS0
Initial value	0	0	0	0	0	0	0	0
Read/Write	R/W	R/W	R/W	R/W	R/W	R/W	R/W	R/W

Clock Select

TCR			STCR		Description
CKS2	CKS1	CKS0	ICKS1	ICKS0	
0	0	0	—	—	Timer stopped
0	0	1	—	0	$\phi_P / 8$ internal clock, falling edge
0	0	1	—	1	$\phi_P / 2$ internal clock, falling edge
0	1	0	—	0	$\phi_P / 64$ internal clock, falling edge
0	1	0	—	1	$\phi_P / 32$ internal clock, falling edge
0	1	1	—	0	$\phi_P / 1024$ internal clock, falling edge
0	1	1	—	1	$\phi_P / 256$ internal clock, falling edge
1	0	0	—	—	Timer stopped
1	0	1	—	—	External clock, rising edge
1	1	0	—	—	External clock, falling edge
1	1	1	—	—	External clock, rising and falling edges

Counter Clear

0	0	Counter is not cleared.
0	1	Cleared by compare-match A.
1	0	Cleared by compare-match B.
1	1	Cleared on rising edge of external reset input.

Timer Overflow Interrupt Enable

0	Overflow interrupt request is disabled.
1	Overflow interrupt request is enabled.

Compare-Match Interrupt Enable A

0	Compare-match A interrupt request is disabled.
1	Compare-match A interrupt request is enabled.

Compare-Match Interrupt Enable B

0	Compare-match B interrupt request is disabled.
1	Compare-match B interrupt request is enabled.

Bit	7	6	5	4	3	2	1	0
	CMFB	CMFA	OVF	—	OS3*2	OS2*2	OS1*2	OS0*2
Initial value	0	0	0	0	0	0	0	0
Read/Write	R/(W)*1	R/(W)*1	R/(W)*1	—	R/W	R/W	R/W	R/W

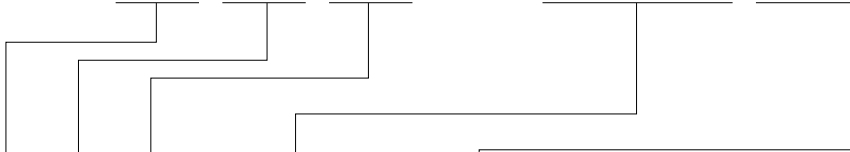

Output Select

0	0	No change on compare-match A.
0	1	Output 0 on compare-match A.
1	0	Output 1 on compare-match A.
1	1	Invert (toggle) output on compare-match A.

Output Select

0	0	No change on compare-match B.
0	1	Output 0 on compare-match B.
1	0	Output 1 on compare-match B.
1	1	Invert (toggle) output on compare-match B.

Timer Overflow Flag

0	Cleared by reading OVF = 1, then writing 0 in OVF.
1	Set when TCNT changes from H'FF to H'00.

Compare-Match Flag A

0	Cleared by reading CMFA = 1, then writing 0 in CMFA.
1	Set when TCNT = TCORA.

Compare-Match Flag B

0	Cleared by reading CMFB = 1, then writing 0 in CMFB.
1	Set when TCNT = TCORB.

- Notes: 1. Software can write a 0 in bits 7 to 5 to clear the flags, but cannot write a 1 in these bits.
 2. When all four bits (OS3 to OS0) are cleared to 0, output is disabled.

TCORA—Time Constant Register A**H'FFCA****TMR0**

Bit	7	6	5	4	3	2	1	0
Initial value	1	1	1	1	1	1	1	1
Read/Write	R/W	R/W	R/W	R/W	R/W	R/W	R/W	R/W

The CMFA bit is set to 1 when TCORA = TCNT.

TCORB—Time Constant Register B**H'FFCB****TMR0**

Bit	7	6	5	4	3	2	1	0
Initial value	1	1	1	1	1	1	1	1
Read/Write	R/W	R/W	R/W	R/W	R/W	R/W	R/W	R/W

The CMFB bit is set to 1 when TCORB = TCNT.

TCNT—Timer Counter**H'FFCC****TMR0**

Bit	7	6	5	4	3	2	1	0
Initial value	0	0	0	0	0	0	0	0
Read/Write	R/W	R/W	R/W	R/W	R/W	R/W	R/W	R/W

Count value

Bit	7	6	5	4	3	2	1	0
	CMIEB	CMIEA	OVIE	CCLR1	CCLR0	CKS2	CKS1	CKS0
Initial value	0	0	0	0	0	0	0	0
Read/Write	R/W	R/W	R/W	R/W	R/W	R/W	R/W	R/W

Clock Select

TCR			STCR		Description
CKS2	CKS1	CKS0	ICKS1	ICKS0	
0	0	0	—	—	Timer stopped
0	0	1	0	—	$\phi_P / 8$ internal clock, falling edge
0	0	1	1	—	$\phi_P / 2$ internal clock, falling edge
0	1	0	0	—	$\phi_P / 64$ internal clock, falling edge
0	1	0	1	—	$\phi_P / 128$ internal clock, falling edge
0	1	1	0	—	$\phi_P / 1024$ internal clock, falling edge
0	1	1	1	—	$\phi_P / 2048$ internal clock, falling edge
1	0	0	—	—	Timer stopped
1	0	1	—	—	External clock, rising edge
1	1	0	—	—	External clock, falling edge
1	1	1	—	—	External clock, rising and falling edges

Counter Clear

0	0	Counter is not cleared.
0	1	Cleared by compare-match A.
1	0	Cleared by compare-match B.
1	1	Cleared on rising edge of external reset input.

Timer Overflow Interrupt Enable

0	Overflow interrupt request is disabled.
1	Overflow interrupt request is enabled.

Compare-Match Interrupt Enable A

0	Compare-match A interrupt request is disabled.
1	Compare-match A interrupt request is enabled.

Compare-Match Interrupt Enable B

0	Compare-match B interrupt request is disabled.
1	Compare-match B interrupt request is enabled.

TCSR—Timer Control/Status Register**H'FFD1****TMR1**

Bit	7	6	5	4	3	2	1	0
	CMFB	CMFA	OVF	—	OS3*2	OS2*2	OS1*2	OS0*2
Initial value	0	0	0	1	0	0	0	0
Read/Write	R/(W)*1	R/(W)*1	R/(W)*1	—	R/W	R/W	R/W	R/W

Notes: Bit functions are the same as for TMR0.

1. Software can write a 0 in bits 7 to 5 to clear the flags, but cannot write a 1 in these bits.
2. When all four bits (OS3 to OS0) are cleared to 0, output is disabled.

TCORA—Time Constant Register A**H'FFD2****TMR1**

Bit	7	6	5	4	3	2	1	0
Initial value	1	1	1	1	1	1	1	1
Read/Write	R/W	R/W	R/W	R/W	R/W	R/W	R/W	R/W

Note: Bit functions are the same as for TMR0.

TCORB—Time Constant Register B**H'FFD3****TMR1**

Bit	7	6	5	4	3	2	1	0
Initial value	1	1	1	1	1	1	1	1
Read/Write	R/W	R/W	R/W	R/W	R/W	R/W	R/W	R/W

Note: Bit functions are the same as for TMR0.

TCNT—Timer Counter**H'FFD4****TMR1**

Bit	7	6	5	4	3	2	1	0
Initial value	0	0	0	0	0	0	0	0
Read/Write	R/W	R/W	R/W	R/W	R/W	R/W	R/W	R/W

Note: Bit functions are the same as for TMR0.

Bit	7	6	5	4	3	2	1	0
	C/ \bar{A}	CHR	PE	O/ \bar{E}	STOP	MP	CKS1	CKS0
Initial value	0	0	0	0	0	0	0	0
Read/Write	R/W	R/W	R/W	R/W	R/W	R/W	R/W	R/W

Clock Select

0	0	\emptyset clock
0	1	$\emptyset_P / 4$ clock
1	0	$\emptyset_P / 16$ clock
1	1	$\emptyset_P / 64$ clock

Multiprocessor Mode

0	Multiprocessor function disabled
1	Multiprocessor format selected

Stop Bit Length

0	One stop bit
1	Two stop bits

Parity Mode

0	Even parity
1	Odd parity

Parity Enable

0	Transmit: No parity bit added. Receive: Parity bit not checked.
1	Transmit: Parity bit added. Receive: Parity bit checked.

Character Length

0	8-bit data length
1	7-bit data length

Communication Mode

0	Asynchronous
1	Synchronous

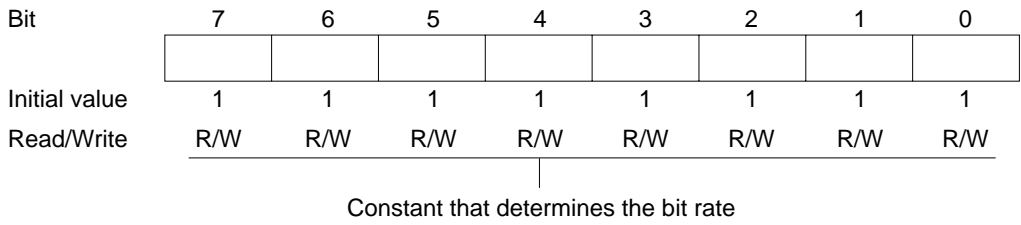

Bit	7	6	5	4	3	2	1	0
	TIE	RIE	TE	RE	MPIE	TEIE	CKE1	CKE0
Initial value	0	0	0	0	0	0	0	0
Read/Write	R/W	R/W	R/W	R/W	R/W	R/W	R/W	R/W

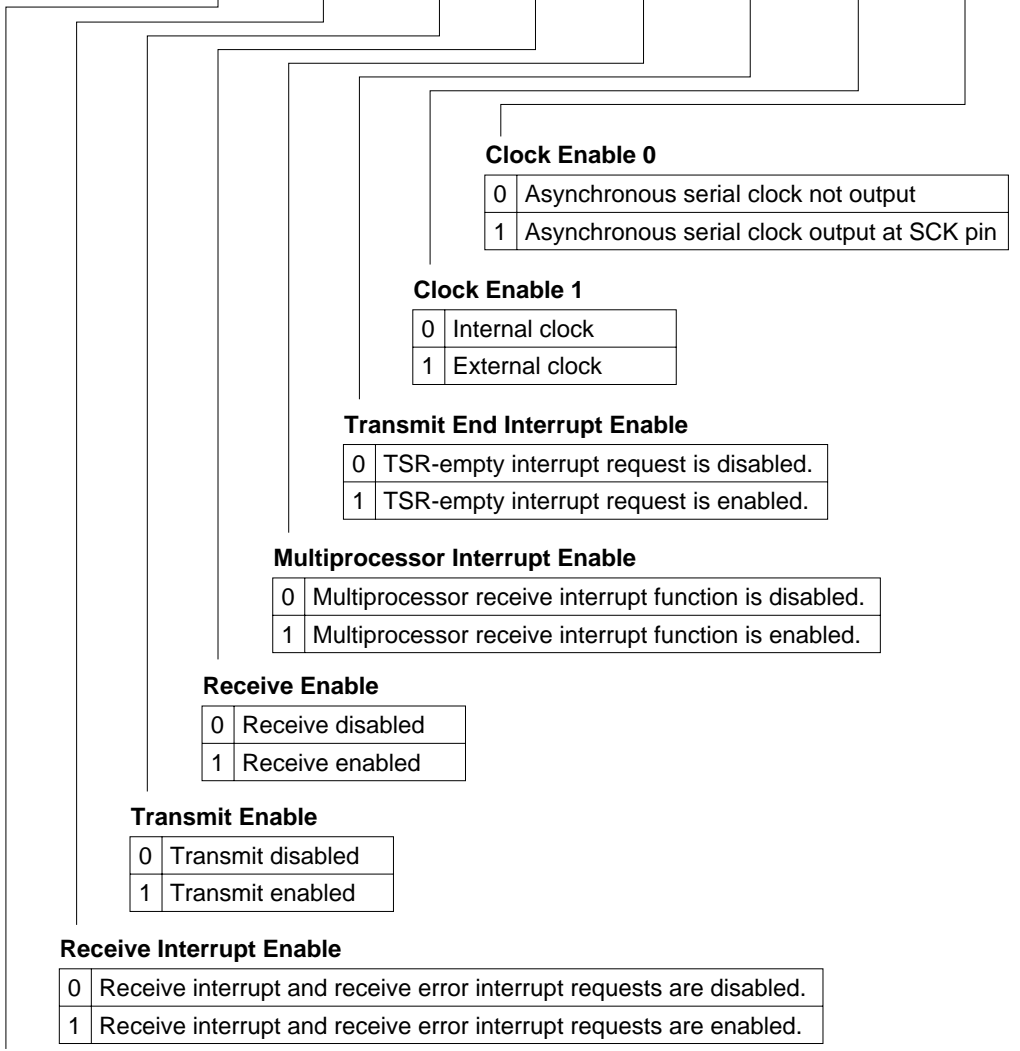

Transmit Interrupt Enable

0	TDR-empty interrupt request is disabled.
1	TDR-empty interrupt request is enabled.

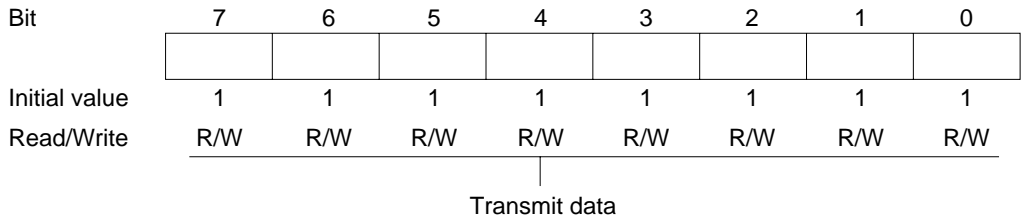

Bit	7	6	5	4	3	2	1	0
	TDRE	RDRF	ORER	FER	PER	TEND	MPB	MPBT
Initial value	1	0	0	0	0	1	0	0
Read/Write	R/(W)*	R/(W)*	R/(W)*	R/(W)*	R/(W)*	R	R	R/W

Multiprocessor Bit Transfer

0	Multiprocessor bit = 0 in transmit data.
1	Multiprocessor bit = 1 in transmit data.

Multiprocessor Bit

0	Multiprocessor bit = 0 in receive data.
1	Multiprocessor bit = 1 in receive data.

Transmit End

0	Cleared by reading TDRE = 1, then writing 0 in TDRE.
1	Set to 1 when TE = 0, or when TDRE = 1 at the end of character transmission.

Parity Error

0	Cleared by reading PER = 1, then writing 0 in PER.
1	Set when a parity error occurs (parity of receive data does not match parity selected by O/E bit in SMR).

Framing Error

0	Cleared by reading FER = 1, then writing 0 in FER.
1	Set when a framing error occurs (stop bit is 0).

Overrun Error

0	Cleared by reading ORER = 1, then writing 0 in ORER.
1	Set when an overrun error occurs (next data is completely received while RDRF bit is set to 1).

Receive Data Register Full

0	Cleared by reading RDRF = 1, then writing 0 in RDRF.
1	Set when one character is received normally and transferred from RSR to RDR.

Transmit Data Register Empty

0	Cleared by reading TDRE = 1, then writing 0 in TDRE.
1	Set when: <ol style="list-style-type: none"> 1. Data is transferred from TDR to TSR. 2. TE is cleared while TDRE = 0.

Note: * Software can write a 0 in bits 7 to 3 to clear the flags, but cannot write a 1 in these bits.

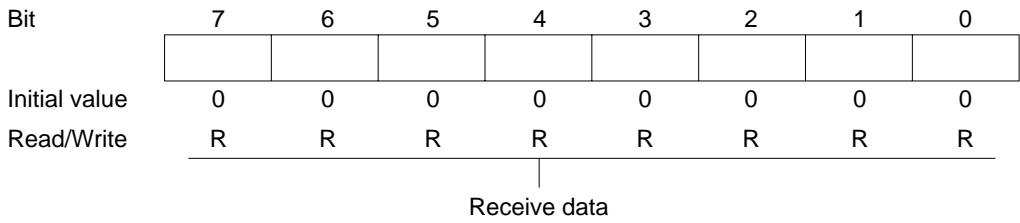

ADDRA (H and L)—A/D Data Register A**H'FFE0, H'FFE1****A/D**

Bit	15	14	13	12	11	10	9	8	7	6	5	4	3	2	1	0
	AD9	AD8	AD7	AD6	AD5	AD4	AD3	AD2	AD1	AD0	—	—	—	—	—	—
Initial value	0	0	0	0	0	0	0	0	0	0	0	0	0	0	0	0
Read/Write	R	R	R	R	R	R	R	R	R	R	R	R	R	R	R	R

} ADDR AH
} ADDR AL

A/D Conversion Data
 10-bit data giving an A/D conversion result

Reserved Bits

ADDRB (H and L)—A/D Data Register B**H'FFE2, H'FFE3****A/D**

Bit	15	14	13	12	11	10	9	8	7	6	5	4	3	2	1	0
	AD9	AD8	AD7	AD6	AD5	AD4	AD3	AD2	AD1	AD0	—	—	—	—	—	—
Initial value	0	0	0	0	0	0	0	0	0	0	0	0	0	0	0	0
Read/Write	R	R	R	R	R	R	R	R	R	R	R	R	R	R	R	R

} ADDR BH
} ADDR BL

A/D Conversion Data
 10-bit data giving an A/D conversion result

Reserved Bits

ADDRC (H and L)—A/D Data Register C
H'FFE4, H'FFE5
A/D

Bit	15	14	13	12	11	10	9	8	7	6	5	4	3	2	1	0
	AD9	AD8	AD7	AD6	AD5	AD4	AD3	AD2	AD1	AD0	—	—	—	—	—	—
Initial value	0	0	0	0	0	0	0	0	0	0	0	0	0	0	0	0
Read/Write	R	R	R	R	R	R	R	R	R	R	R	R	R	R	R	R
	ADDRCH										ADDRCL					
	A/D Conversion Data 10-bit data giving an A/D conversion result										Reserved Bits					

ADDRD (H and L)—A/D Data Register D
H'FFE6, H'FFE7
A/D

Bit	15	14	13	12	11	10	9	8	7	6	5	4	3	2	1	0
	AD9	AD8	AD7	AD6	AD5	AD4	AD3	AD2	AD1	AD0	—	—	—	—	—	—
Initial value	0	0	0	0	0	0	0	0	0	0	0	0	0	0	0	0
Read/Write	R	R	R	R	R	R	R	R	R	R	R	R	R	R	R	R
	ADDRDH										ADDRDL					
	A/D Conversion Data 10-bit data giving an A/D conversion result										Reserved Bits					

Bit	7	6	5	4	3	2	1	0
	ADF	ADIE	ADST	SCAN	CKS	CH2	CH1	CH0
Initial value	0	0	0	0	0	0	0	0
Read/Write	R/(W)*	R/W	R/W	R/W	R/W	R/W	R/W	R/W

Channel Select

CH2	CH1	CH0	Single Mode	Scan Mode
0	0	0	AN ₀	AN ₀
		1	AN ₁	AN ₀ , AN ₁
	1	0	AN ₂	AN ₀ to AN ₂
		1	AN ₃	AN ₀ to AN ₃
1	0	0	AN ₄	AN ₄
		1	AN ₅	AN ₄ , AN ₅
	1	0	AN ₆	AN ₄ to AN ₆
		1	AN ₇	AN ₄ to AN ₇

Clock Select

0	Conversion time = 266 states (max)
1	Conversion time = 134 states (max)

Note: When $\phi_P = \emptyset$

Scan Mode

0	Single mode
1	Scan mode

A/D Start

0	A/D conversion is halted.
1	<ol style="list-style-type: none"> Single mode: One A/D conversion is performed, then this bit is automatically cleared to 0. Scan mode: A/C conversion starts and continues cyclically on all selected channels until 0 is written in this bit.

A/D Interrupt Enable

0	The A/D interrupt request (ADI) is disabled.
1	The A/D interrupt request (ADI) is enabled.

A/D End Flag

0	Cleared from 1 to 0 when CPU reads ADF = 1, then writes 0 in ADF.
1	Set to 1 at the following times: <ol style="list-style-type: none"> Single mode: at the completion of A/D conversion Scan mode: when all selected channels have been converted.

Note: * Only 0 can be written, to clear the flag.

Bit	7	6	5	4	3	2	1	0
TRGE	—	—	—	—	—	—	—	—
Initial value	0	1	1	1	1	1	1	1
Read/Write	R/W	—	—	—	—	—	—	—

Trigger Enable

0	ADTRG is disabled.
1	ADTRG is enabled. A/D conversion can be started by external trigger, or by software.

Appendix C I/O Port Block Diagrams

C.1 Port 1 Block Diagram

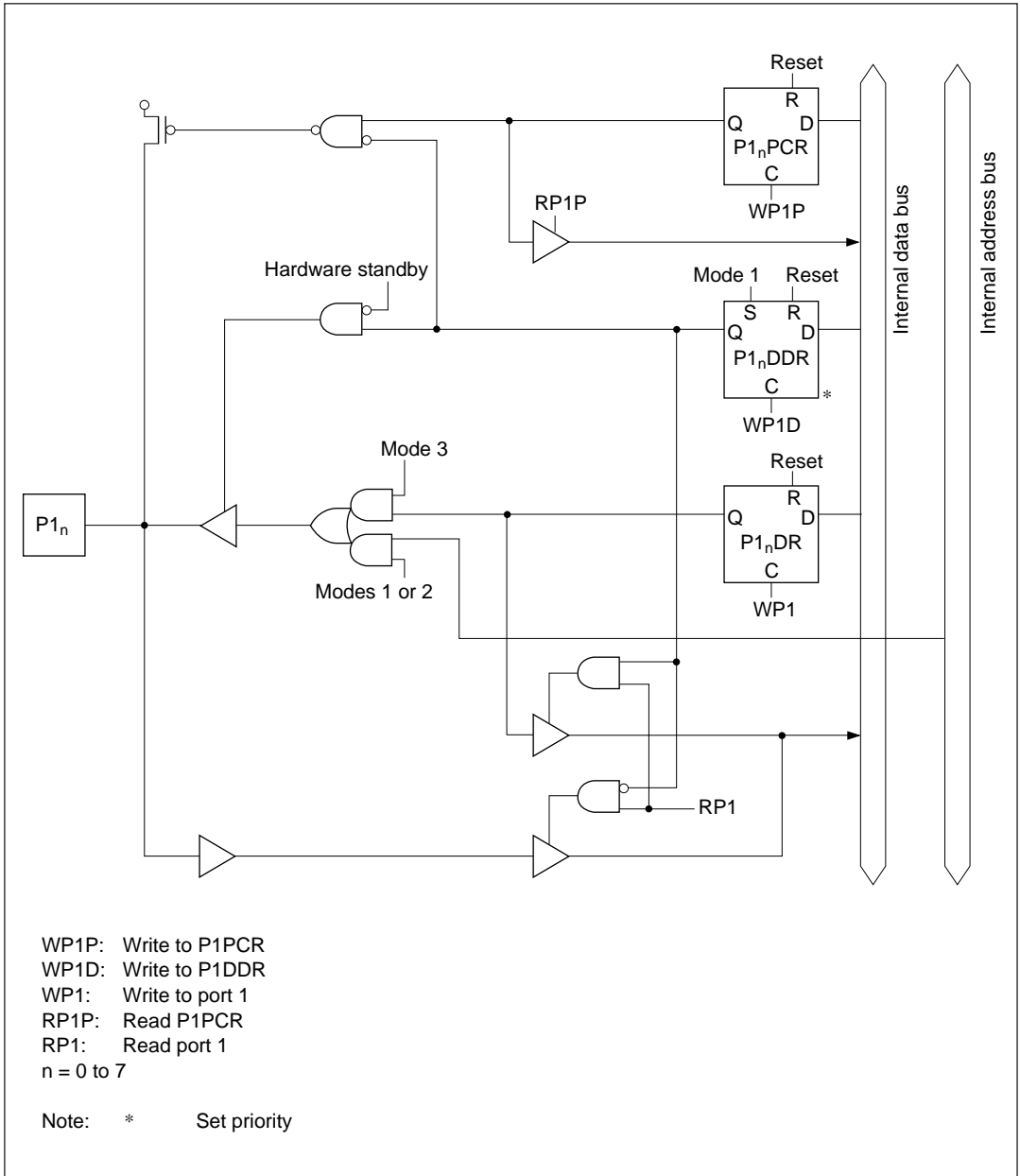

Figure C-1 Port 1 Block Diagram

C.3 Port 3 Block Diagram

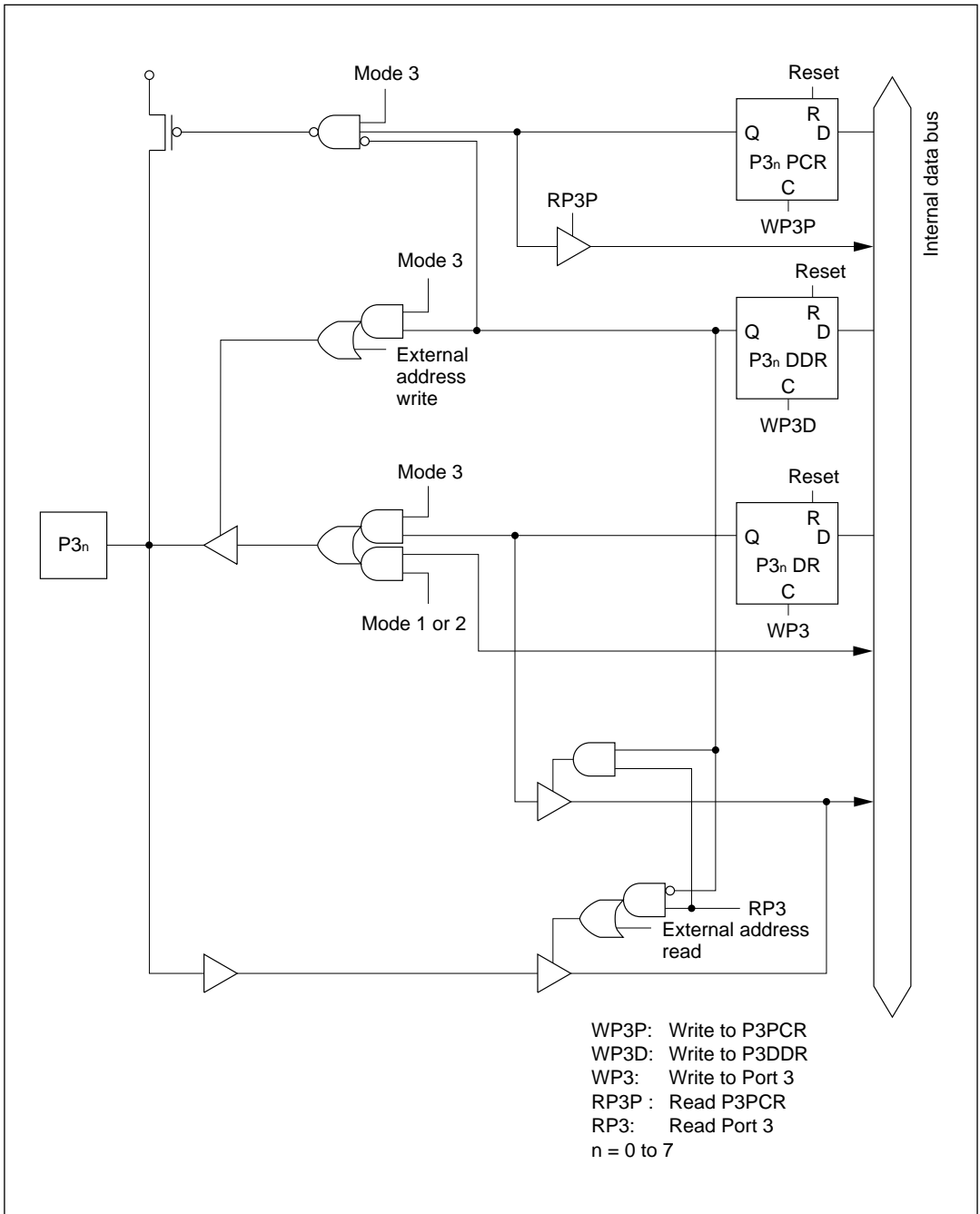

Figure C-3 Port 3 Block Diagram

C.4 Port 4 Block Diagrams

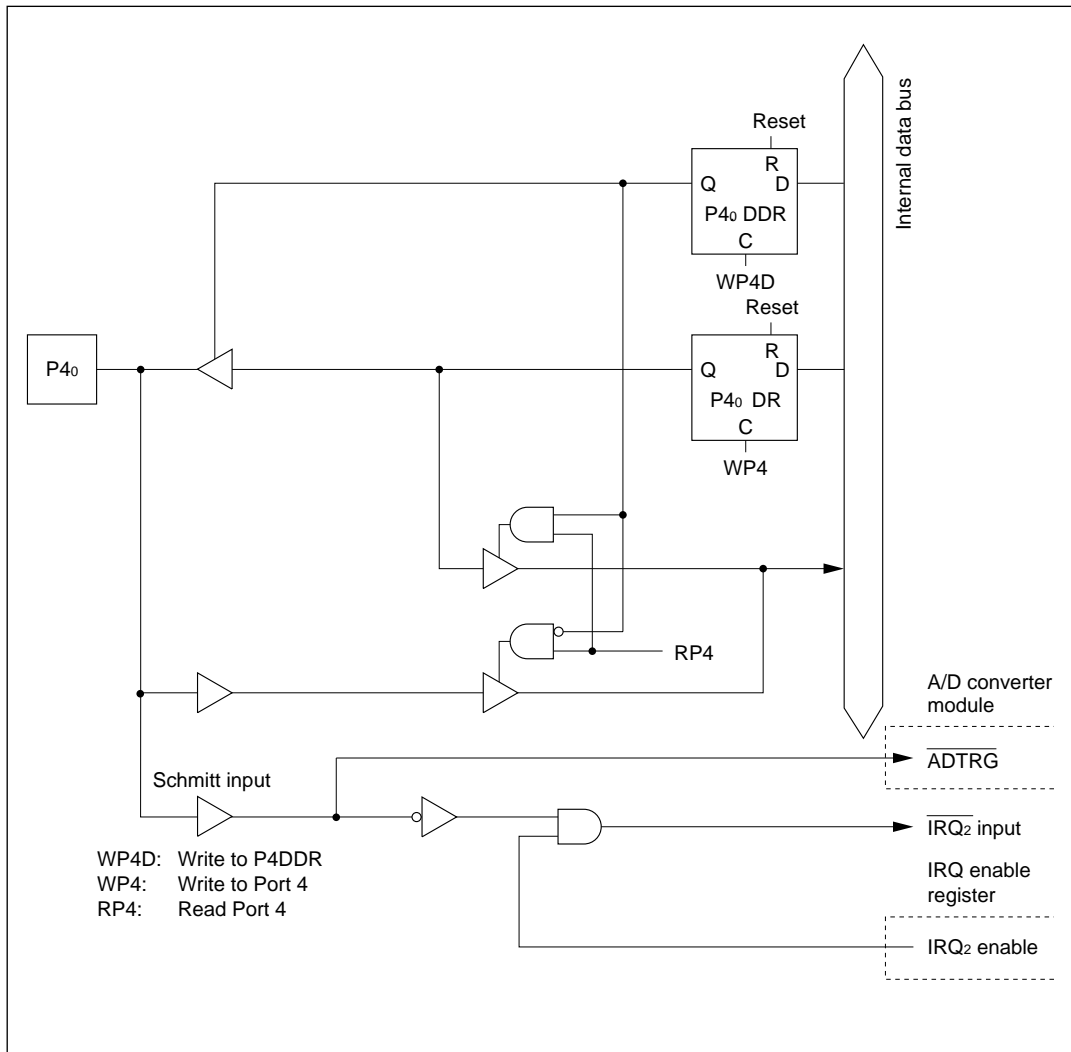

Figure C-4 (a) Port 4 Block Diagram (Pin P4₀)

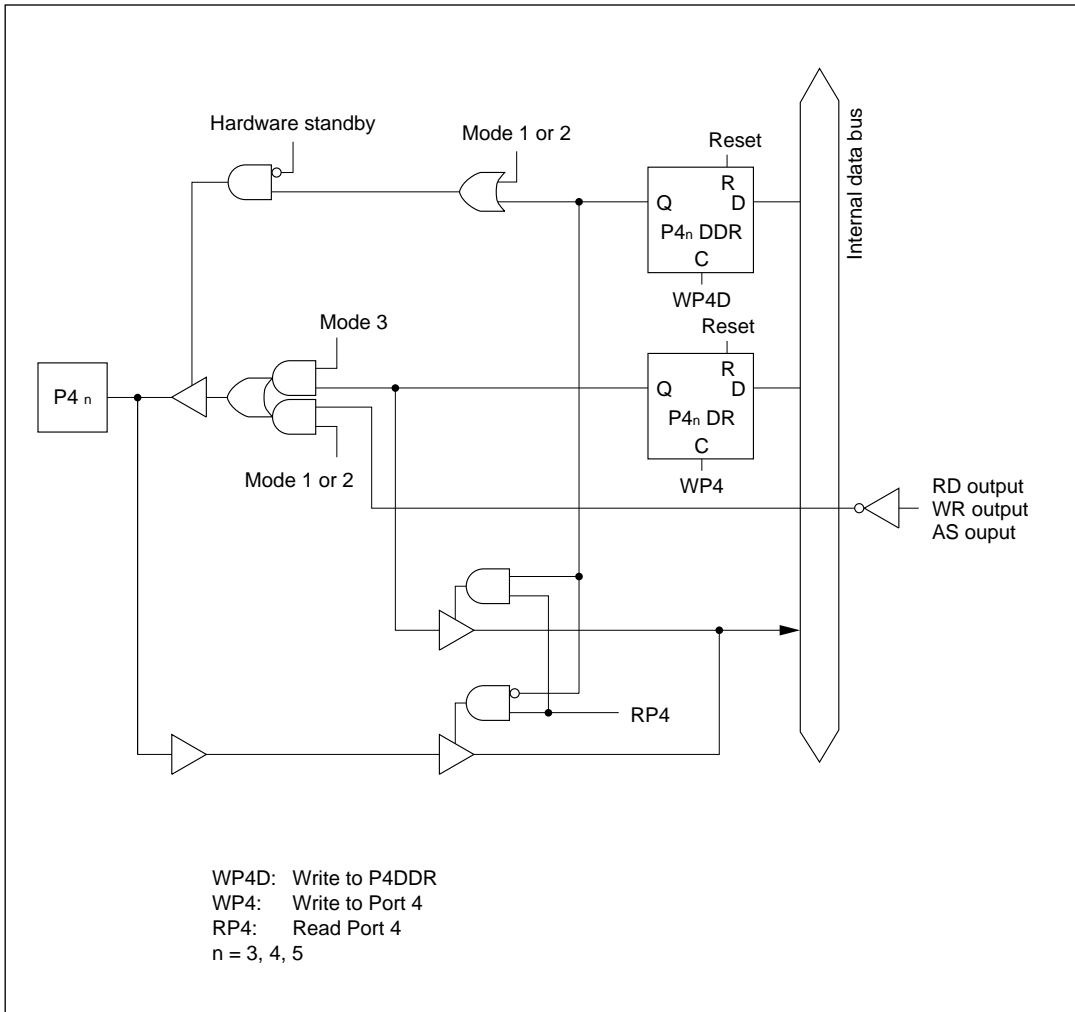

Figure C-4 (c) Port 4 Block Diagram (Pins P4₃ to P4₅)

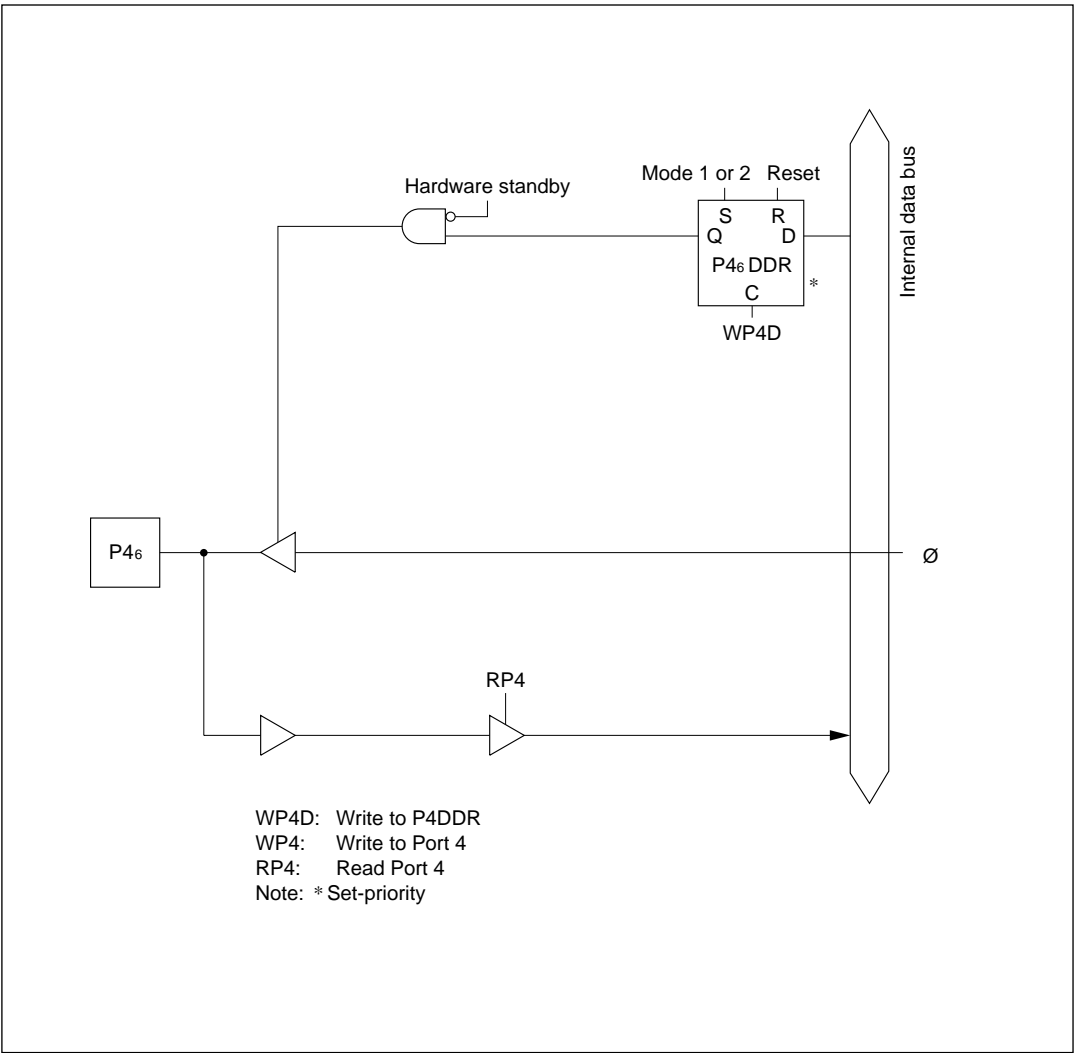

Figure C-4 (d) Port 4 Block Diagram (Pin P4₆)

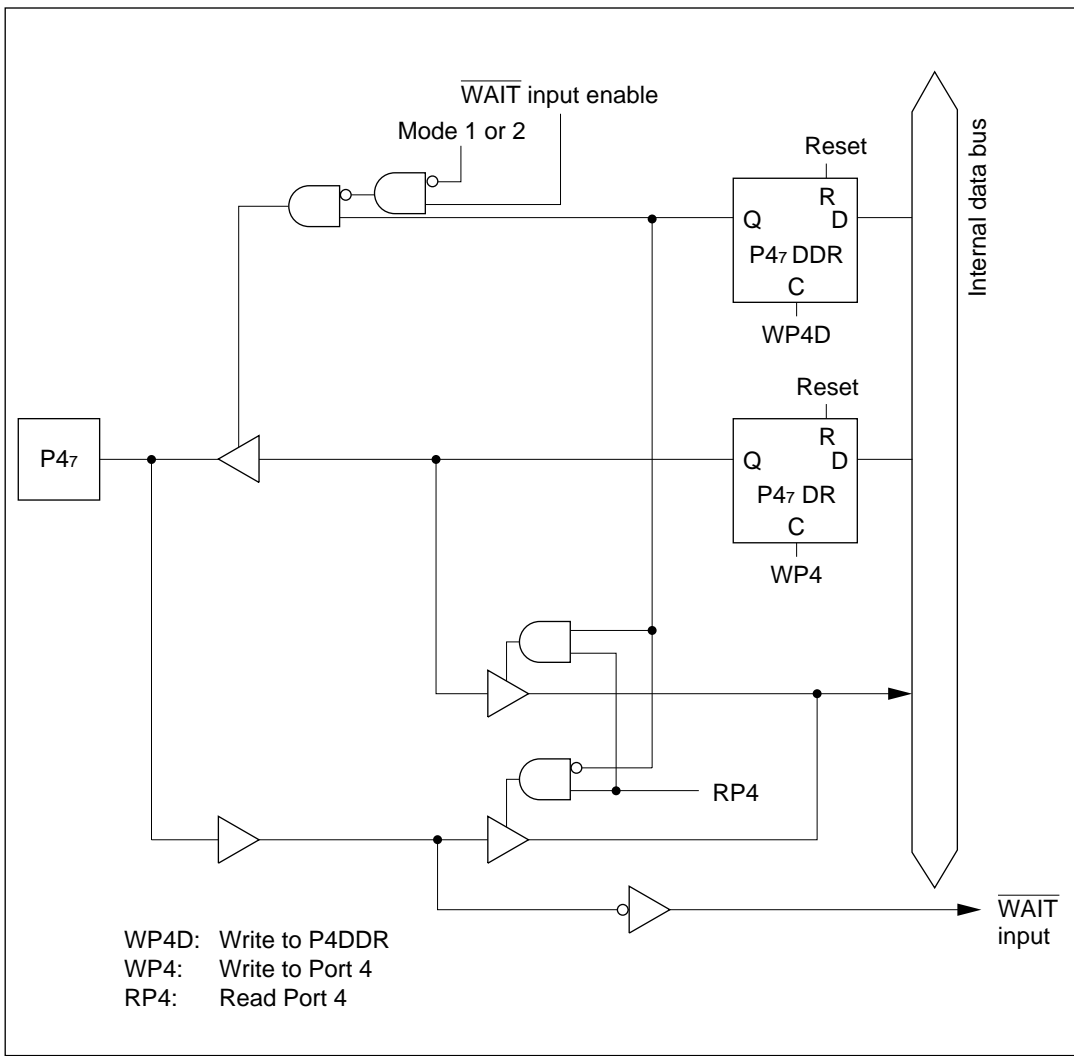

Figure C-4 (e) Port 4 Block Diagram (Pin P47)

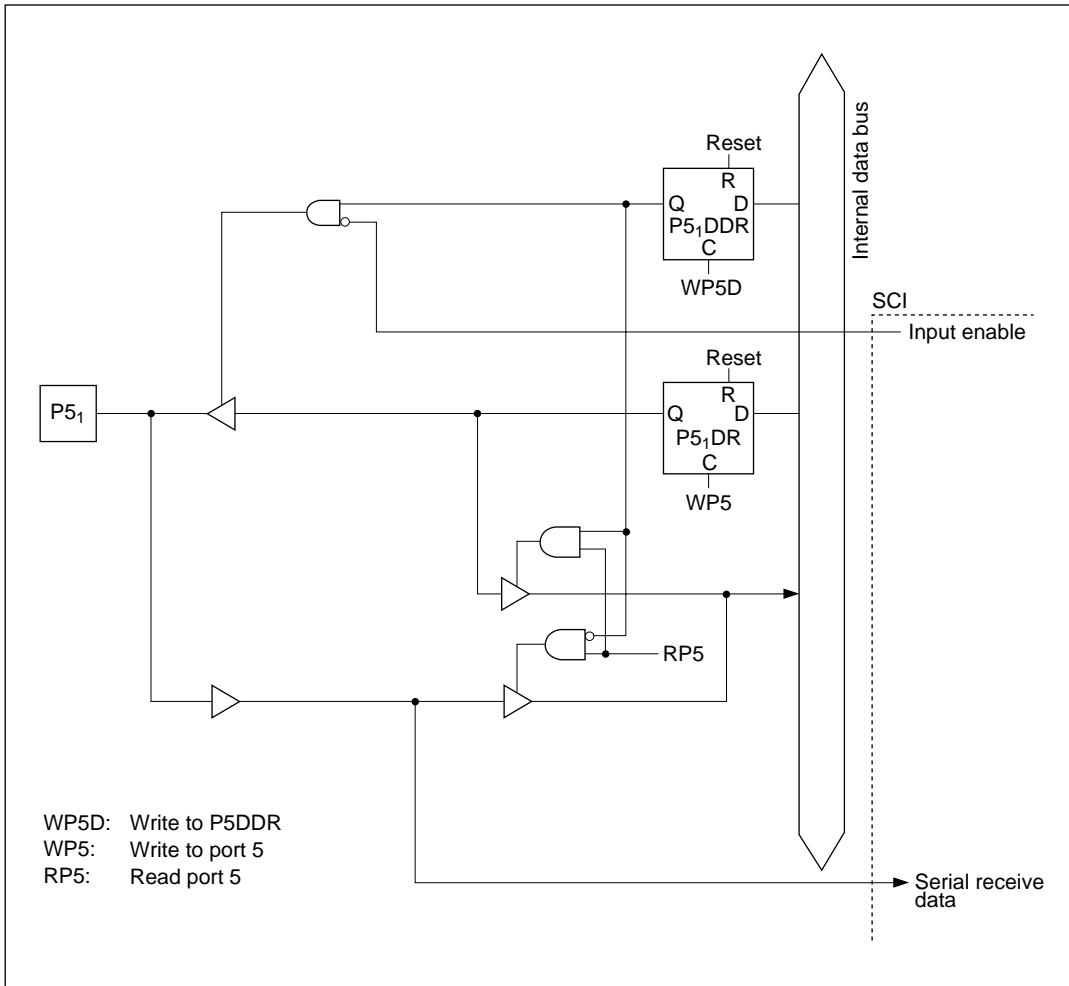

Figure C-5 (b) Port 5 Block Diagram (Pin P5₁)

C.6 Port 6 Block Diagrams

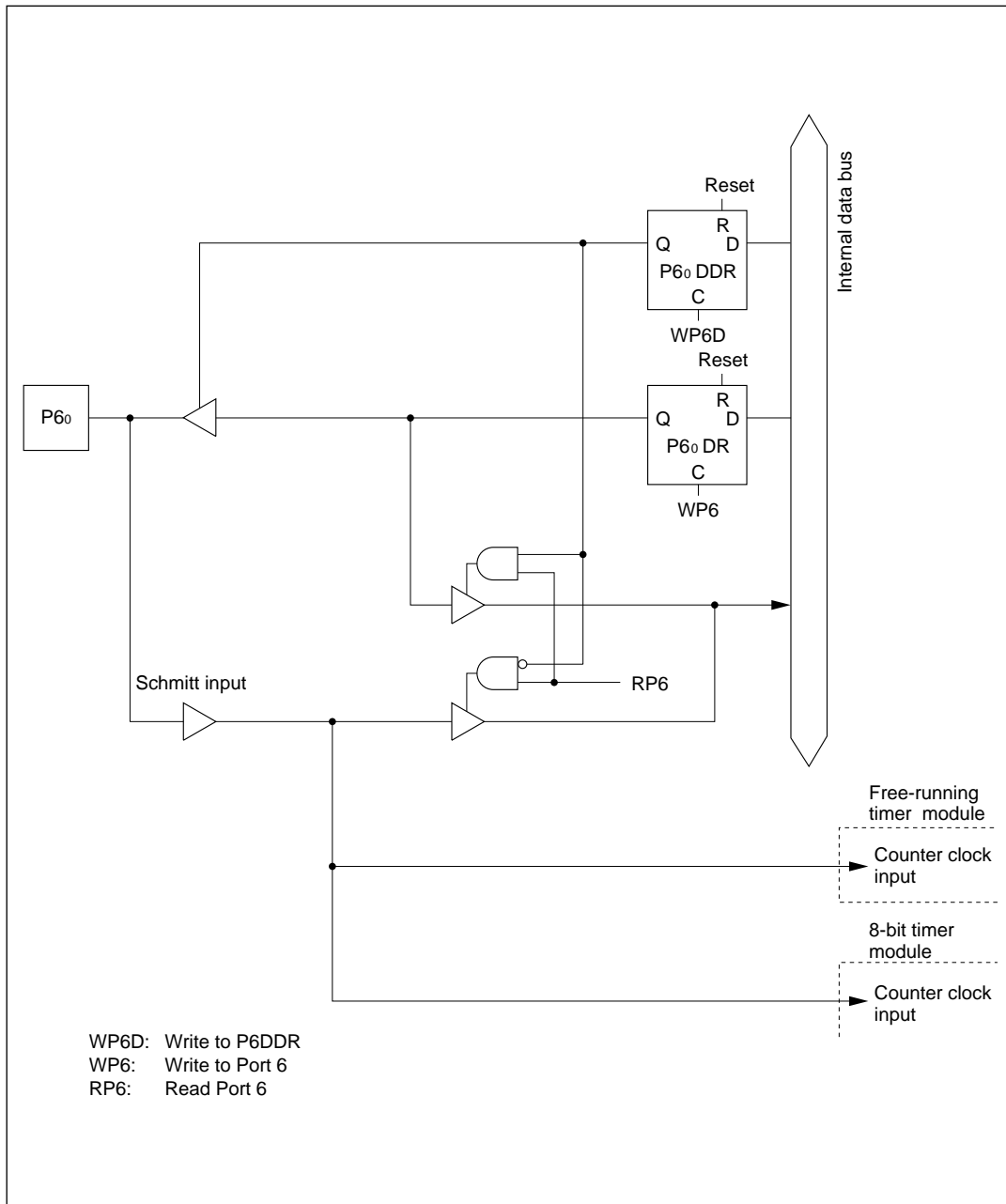

Figure C-6 (a) Port 6 Block Diagram (Pin P60)

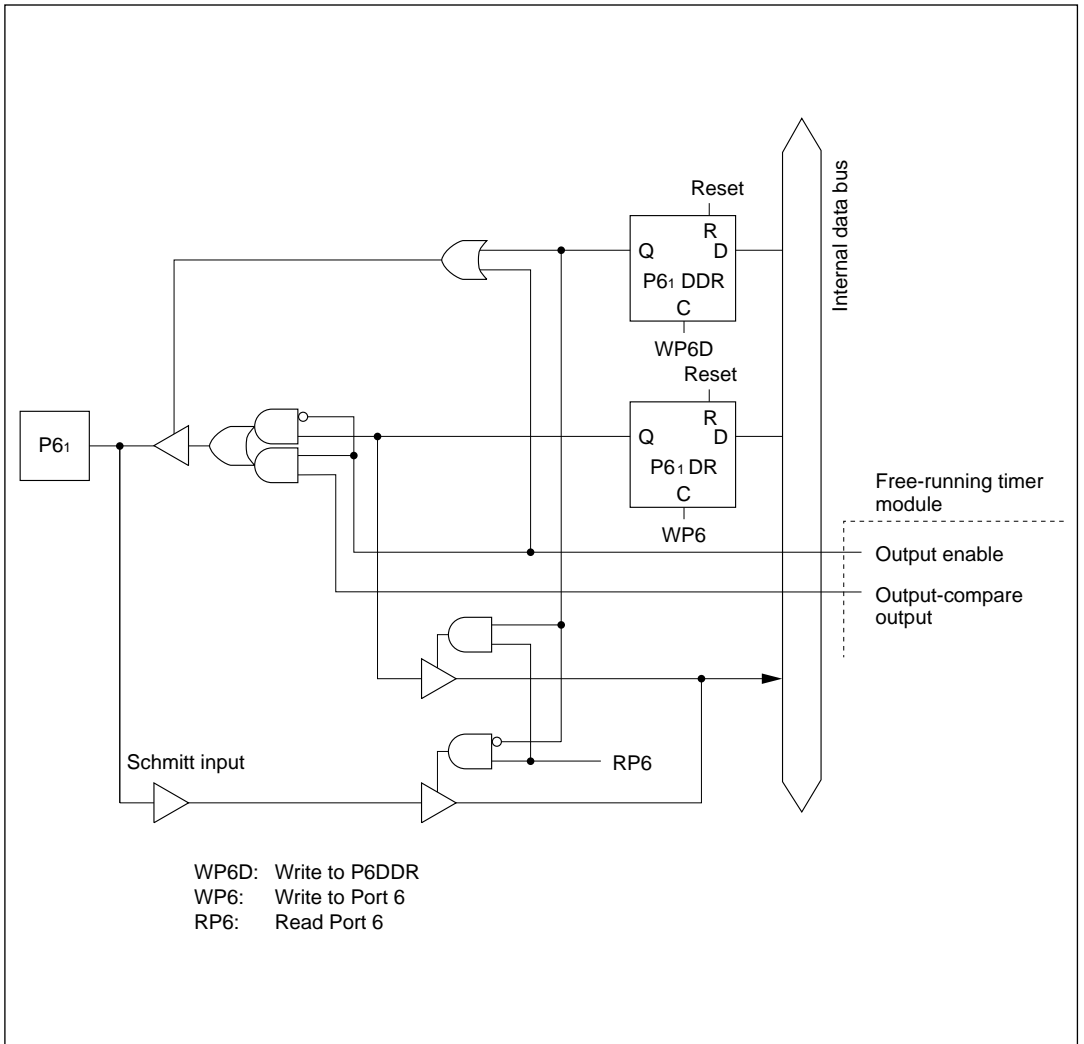

Figure C-6 (b) Port 6 Block Diagram (Pin P6₁)

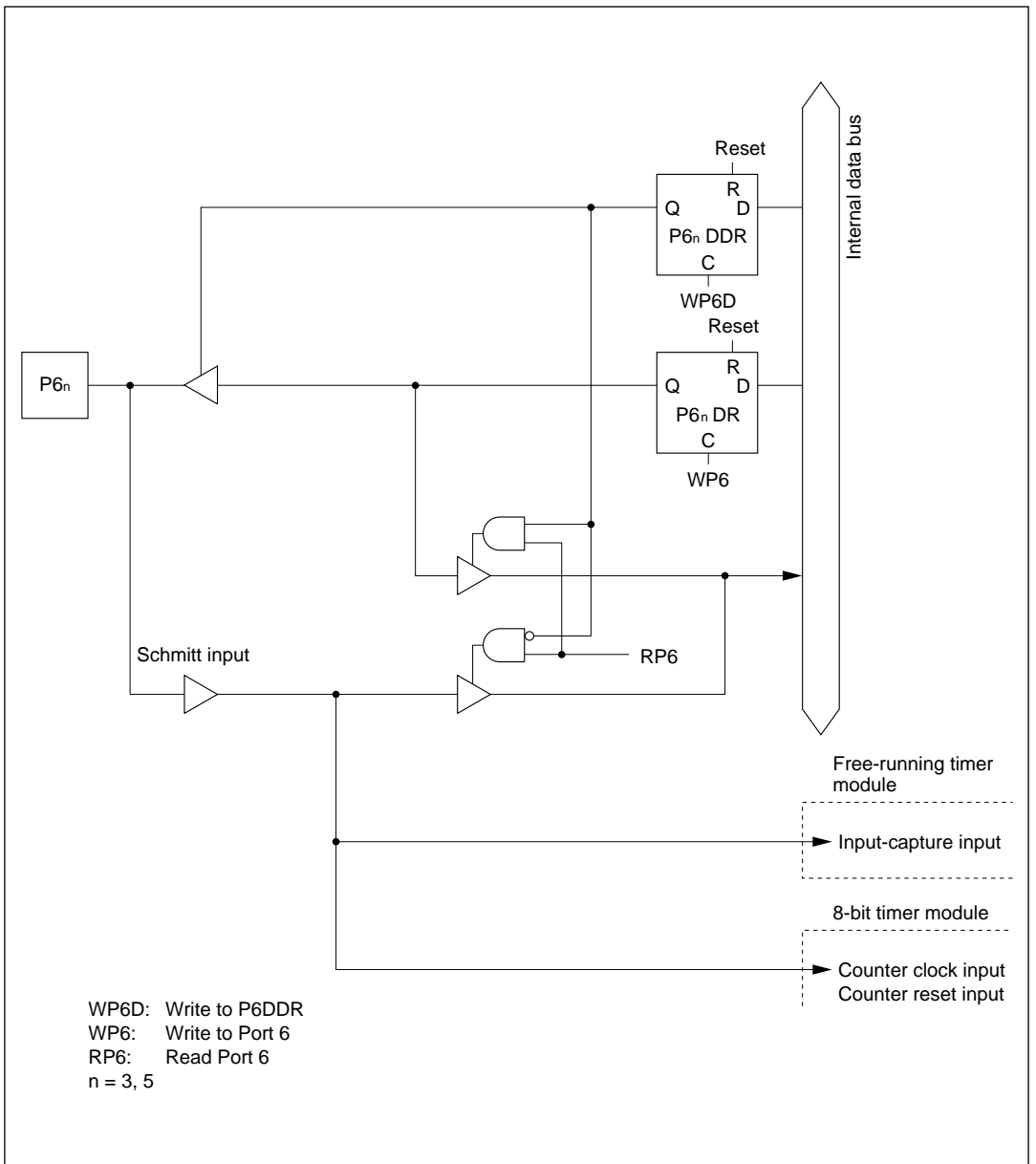

Figure C-6 (d) Port 6 Block Diagram (Pins P6₃ and P6₅)

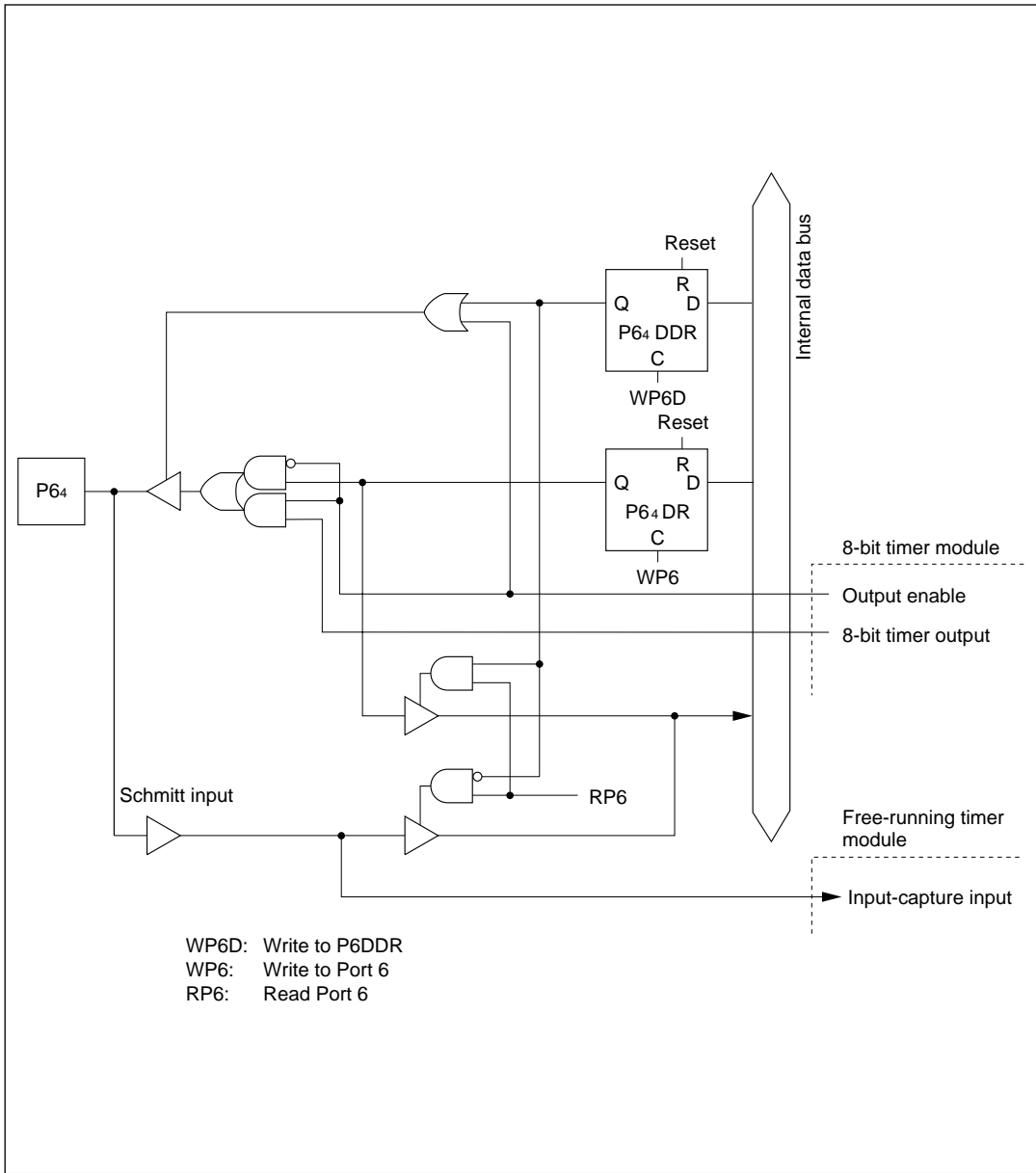

Figure C-6 (e) Port 6 Block Diagram (Pin P64)

C.7 Port 7 Block Diagrams

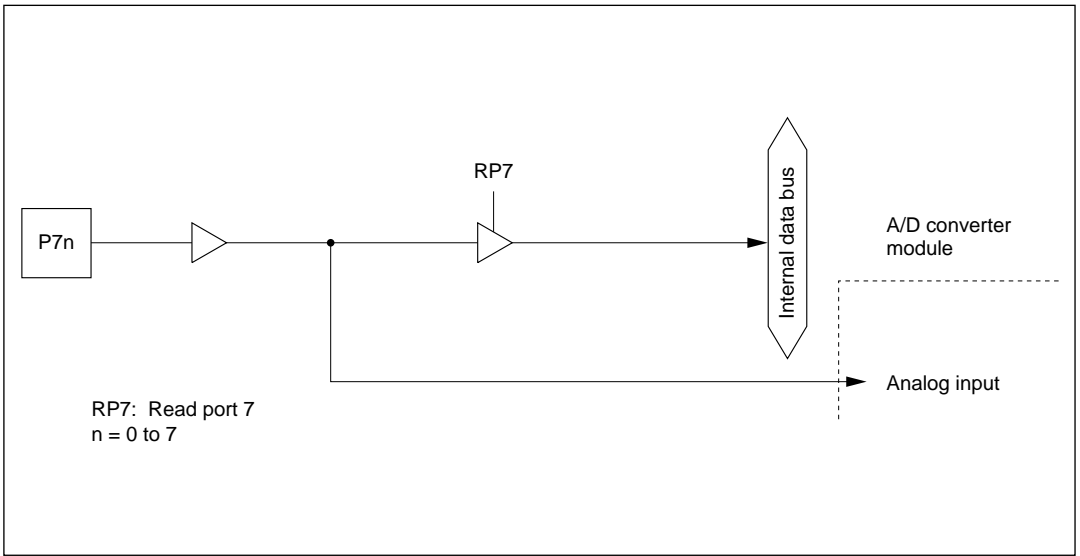

Figure C-7 Port 7 Block Diagram

Appendix D Pin States

D.1 Port States in Each Mode

Table D-1 Port States

Pin Name	Mode	Reset	Hardware Standby	Software Standby	Sleep Mode	Normal Operation
P1 ₇ to P1 ₀	1	Low	3-state	Low	Prev. state (Addr. output pins: last address accessed)	A ₇ to A ₀
A ₇ to A ₀	2	3-state		Low if DDR = 1, prev. state if DDR = 0		Addr. output or input port
	3			Prev. state		I/O port
P2 ₇ to P2 ₀	1	Low	3-state	Low	Prev. state (Addr. output pins: last address accessed)	A ₁₅ to A ₈
A ₁₅ to A ₈	2	3-state		Low if DDR = 1, prev. state if DDR = 0		Addr. output or input port
	3			Prev. state		I/O port
P3 ₇ to P3 ₀	1	3-state	3-state	3-state	3-state	D ₇ to D ₀
D ₇ to D ₀	2					
	3					
P4 ₇ /WAIT	1	3-state	3-state	3-state / Prev. state	3-state / Prev. state	WAIT / I/O port
	2					
	3			Prev. state	Prev. state	I/O port
P4 ₆ /∅	1	Clock output	3-state	High	Clock output	Clock output
	2					
	3			3-state		

- Notes:
1. 3-state: High-impedance state
 2. Prev. state: Previous state. Input ports are in the high-impedance state (with the MOS pull-up on if PCR = 1). Output ports hold their previous output level.
 3. I/O port: Direction depends on the data direction (DDR) bit. Note that these pins may also be used by the on-chip supporting modules. See section 7, I/O Ports, for further information.

* On-chip supporting modules are initialized, so these pins revert to I/O ports according to the DDR and DR bits.

Table D-1 Port States (cont)

Pin Name	Mode	Reset	Hardware Standby	Software Standby	Sleep Mode	Normal Operation
P4 ₅ to P4 ₃ , AS, WR, RD	1	High	3-state	High	High	AS, WR, RD
	2					
	3	3-state	Prev. state	Prev. state	I/O port	
P4 ₂ to P4 ₀	1	3-state	3-state	Prev. state	Prev. state	I/O port
	2					
	3					
P5 ₂ to P5 ₀	1	3-state	3-state	Prev. state*	Prev. state	I/O port
	2					
	3					
P6 ₇ to P6 ₀	1	3-state	3-state	Prev. state*	Prev. state	I/O port
	2					
	3					
P7 ₇ to P7 ₀	1	3-state	3-state	3-state	3-state	Input port
	2					
	3					

Notes: 1. 3-state: High-impedance state

2. Prev. state: Previous state. Input ports are in the high-impedance state (with the MOS pull-up on if PCR = 1). Output ports hold their previous output level.

3. I/O port: Direction depends on the data direction (DDR) bit. Note that these pins may also be used by the on-chip supporting modules. See section 7, I/O Ports, for further information.

* On-chip supporting modules are initialized, so these pins revert to I/O ports according to the DDR and DR bits.

Appendix E Timing of Transition to and Recovery from Hardware Standby Mode

Timing of Transition to Hardware Standby Mode

- (1) To retain RAM contents when the RAME bit in SYSCR is set to 1, drive the $\overline{\text{RES}}$ signal low 10 system clock cycles before the $\overline{\text{STBY}}$ signal goes low, as shown below. $\overline{\text{RES}}$ must remain low until $\overline{\text{STBY}}$ goes low (minimum delay from $\overline{\text{STBY}}$ low to $\overline{\text{RES}}$ high: 0 ns).

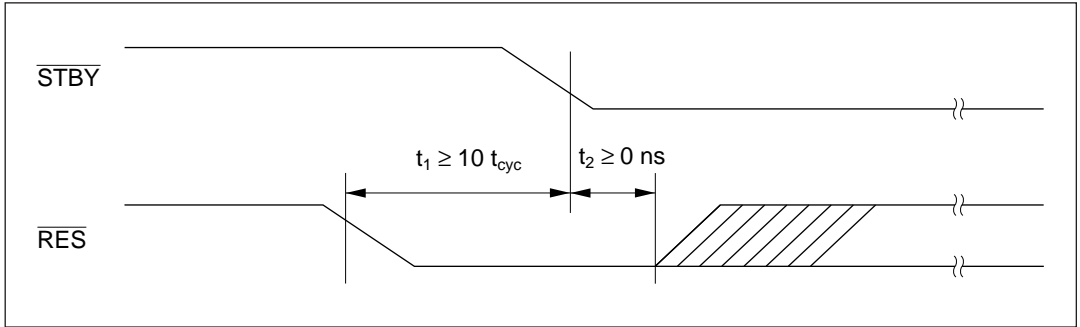

- (2) When the RAME bit in SYSCR is cleared to 0 or when it is not necessary to retain RAM contents, $\overline{\text{RES}}$ does not have to be driven low as in (1).

Timing of Recovery From Hardware Standby Mode: Drive the $\overline{\text{RES}}$ signal low approximately 100 ns before $\overline{\text{STBY}}$ goes high.

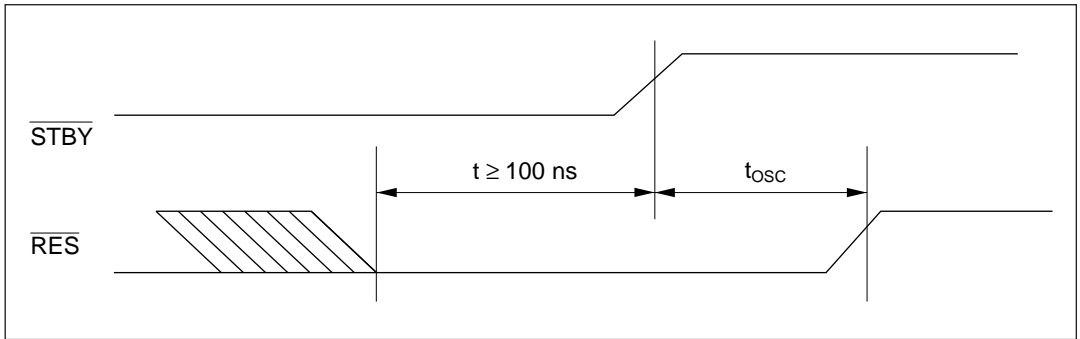

Appendix F Product Code Lineup

Table F-1 H8/3297 Series Product Code Lineup

Product Type			Product Code	Mark Code	Package (Hitachi Package Code)
H8/3297	ZTAT version	Standard products	HD6473297C16	HD6473297C16	64-pin window shrink DIP (DC-64S)
			HD6473297P16	HD6473297P16	64-pin shrink DIP (DP-64S)
			HD6473297F16	HD6473297F16	64-pin QFP (FP-64A)
			HD6473297TF16	HD6473297TF16	80-pin TQFP (TFP-80C)
	Mask ROM version	Standard products	HD6433297P	HD6433297(***)P	64-pin shrink DIP (DC-64S)
			HD6433297F	HD6433297(***)F	64-pin QFP (FP64A)
			HD6433297TF	HD6433297(***)TF	80-pin TQFP (TFP-80C)
			H8/3296	Mask ROM version	Standard products
HD6433296F	HD6433296(***)F	64-pin QFP (FP-64A)			
HD6433296TF	HD6433296(***)TF	80-pin TQFP (TFP-80C)			

Notes: (***) in mask ROM versions is the ROM code.

Table F-1 H8/3297 Series Product Code Lineup (cont)

Product Type			Product Code	Mark Code	Package (Hitachi Package Code)
H8/3294*	ZTAT version	Standard products	HD6473294P16	HD6473294P16	64-pin shrink DIP (DP-64S)
			HD6473294F16	HD6473294F16	64-pin QFP (FP-64A)
			HD6473294TF16	HD6473294TF16	80-pin TQFP (TFP-80C)
	Mask ROM version	Standard products	HD6433294P	HD6433294(***)P	64-pin shrink DIP (DP-64S)
			HD6433294F	HD6433294(***)F	64-pin QFP (FP64A)
			HD6433294TF	HD6433294(***)TF	80-pin TQFP (TFP-80C)
H8/3292	Mask ROM version	Standard products	HD6433292P	HD6433292(***)P	64-pin shrink DIP (DP-64S)
			HD6433292F	HD6433292(***)F	64-pin QFP (FP-64A)
			HD6433292TF	HD6433292(***)TF	80-pin TQFP (TFP-80C)

Notes: (***) in mask ROM versions is the ROM code.

Appendix G Package Dimensions

Figure G-1 shows the dimensions of the DC-64S package. Figure G-2 shows the dimensions of the DP-64S package. Figure G-3 shows the dimensions of the FP-64A package. Figure G-4 shows the dimensions of the TFP-80C package.

Unit: mm

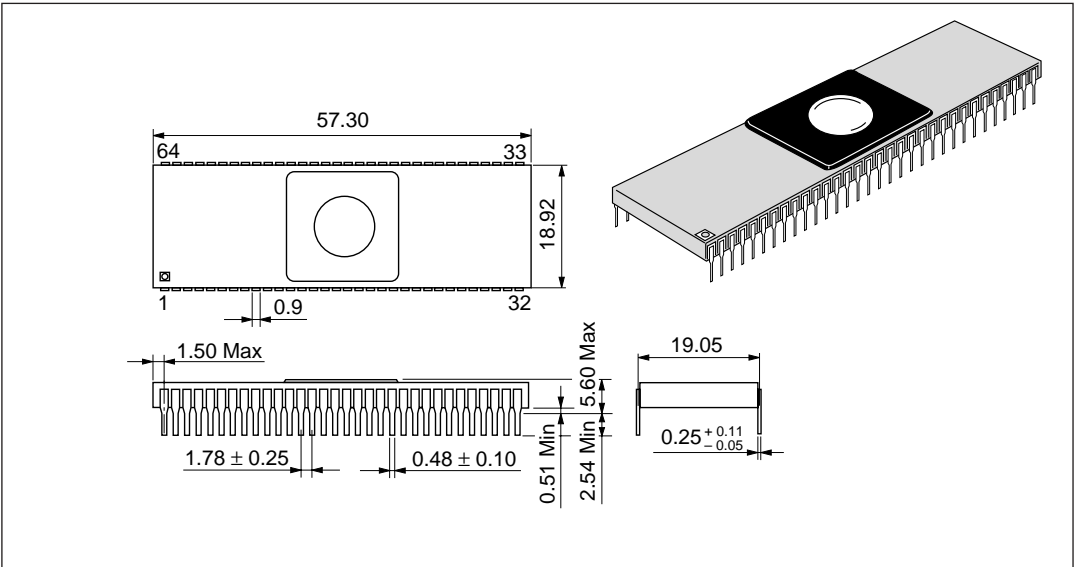

Figure G-1 Package Dimensions (DC-64S)

Unit: mm

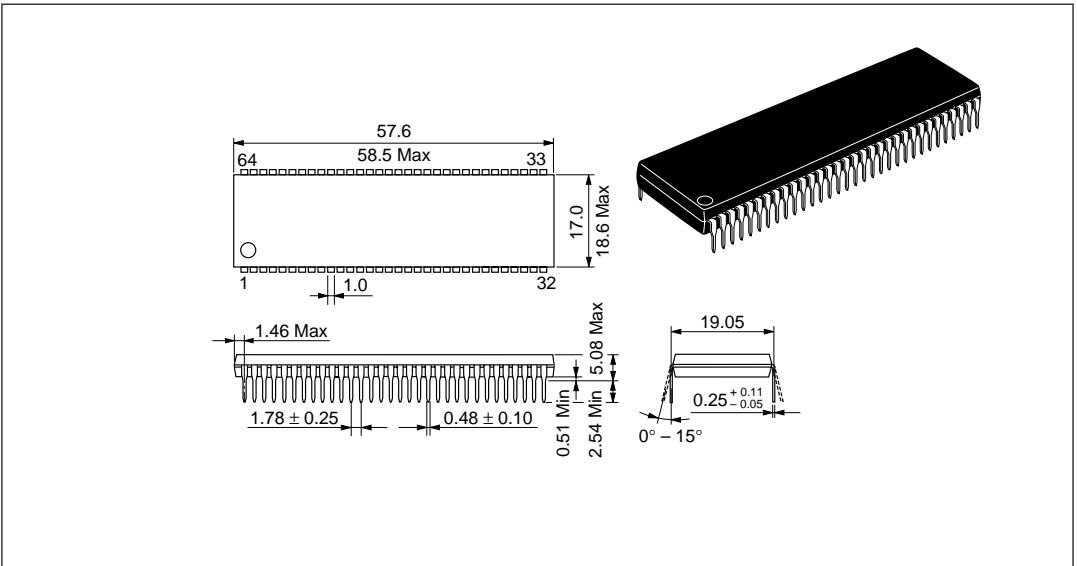

Figure G-2 Package Dimensions (DP-64S)

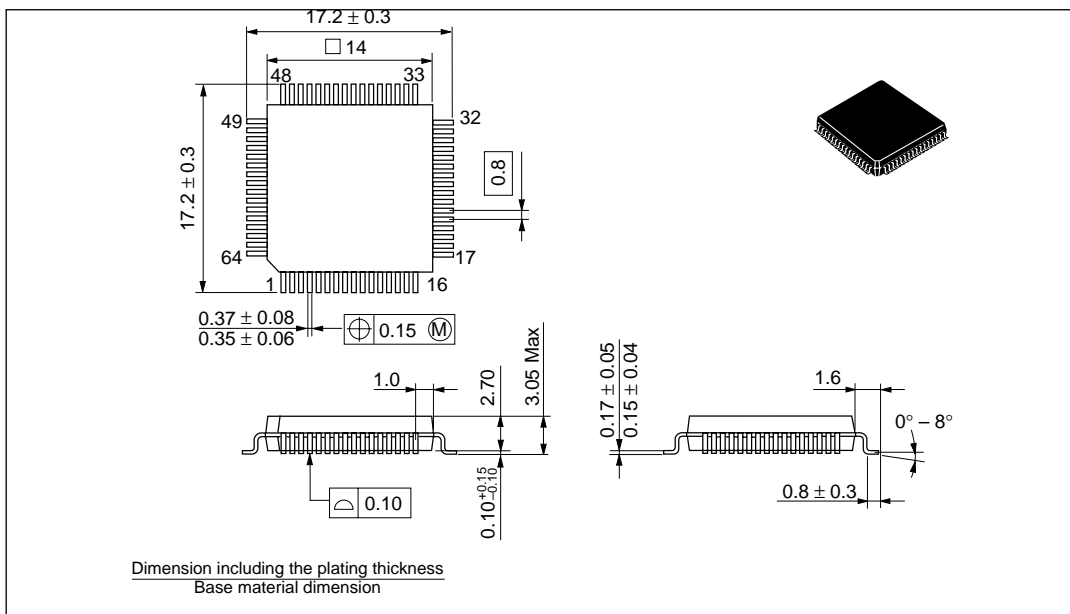

Figure G-3 Package Dimensions (FP-64A)

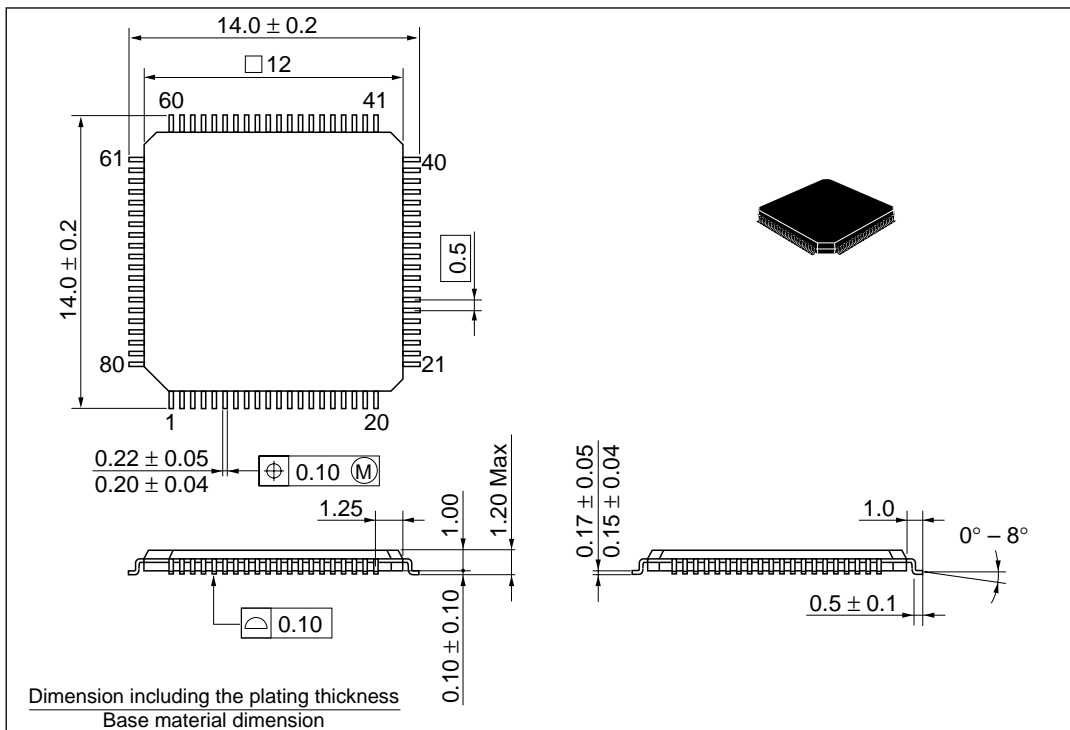

Figure G-4 Package Dimensions (TFP-80C)

H8/3297 Series Hardware Manual

Publication Date: 1st Edition, October 1994
3rd Edition, September 1997

Published by: Semiconductor and IC Div.
Hitachi, Ltd.

Edited by: Technical Documentation Center
Hitachi, Microcomputer System Ltd.

Copyright © Hitachi, Ltd., 1994. All rights reserved. Printed in Japan.