

MTS Stereo Encoder

The MC44C402 Multi-Channel Television Sound (MTS) Stereo Encoder is based on the industry's first, single-chip, CMOS implementation of a Broadcast Television Systems Committee (BTSC)-compatible stereo encoder, the MC44C400.

The MC44C402 MTS Stereo Encoder is designed for use in set-top boxes, VCRs, DVD players/recorders, game stations, and other applications that are required to output high-quality stereo sound through a single RF coaxial cable.

The digital audio processing used in the MC44C402 preserves the full fidelity of surround sound and other audio coding schemes while ensuring overall system performance is not impacted by copy protection technologies.

The MC44C402 is engineered to process right and left analog audio signals and baseband composite video to generate a stereophonic composite signal in accordance with BTSC system standards. The MC44C402 is designed to output this signal to a Freescale RF modulator, which in turn produces a stereo encoded RF channel for use with any BTSC stereo television receiver.

Features

- Integrated A/D converter input and D/A converter output circuitry
- CEX™ digital audio processing encodes and transports stereo signals
- Surround sound and Macrovision™ compatible
- Extended low frequency response (The MC44C402 frequency response extends below 25 Hz)
- Simple passive interface to Freescale's MC44BS373/4 (UHF/VHF) and MC44BC375 (VHF) modulators
- Preservation of original surround sound fidelity
- System performance not impacted by copy protection technologies
- Low system component count, small board size, and significantly low overall system cost
- No manual alignment of filters or phase controls

Reference Documentation

"Multichannel Television Sound Transmission and Audio Processing Requirements for the BTSC System", FCC OET Bulletin No. 60, February 1986.

MC44C402

MTS STEREO ENCODER

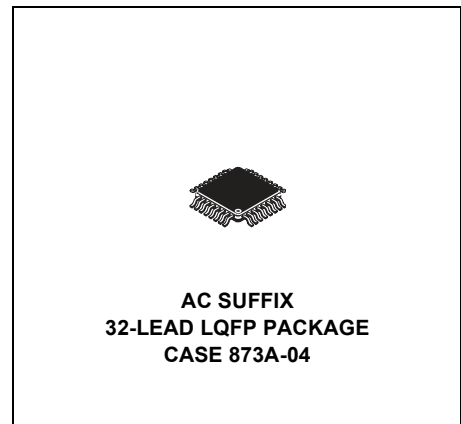

| ORDERING INFORMATION | | | |
|----------------------|----------------|-------------|------|
| Device | Temp. Range | Package | RoHS |
| MC44C402AC | -40°C to +85°C | 32LQFP | yes |
| MC44C402ACR2 | | Tape & Reel | yes |

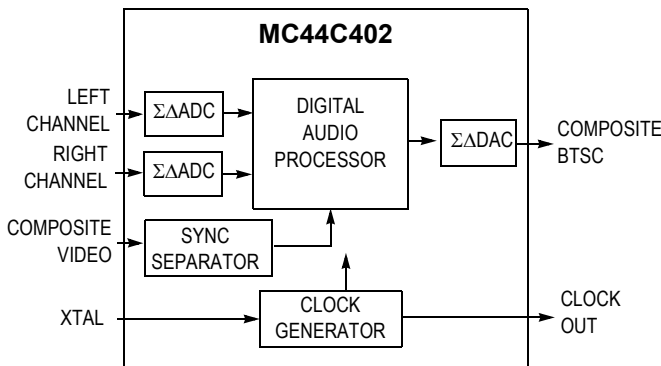

Functional Block Diagram

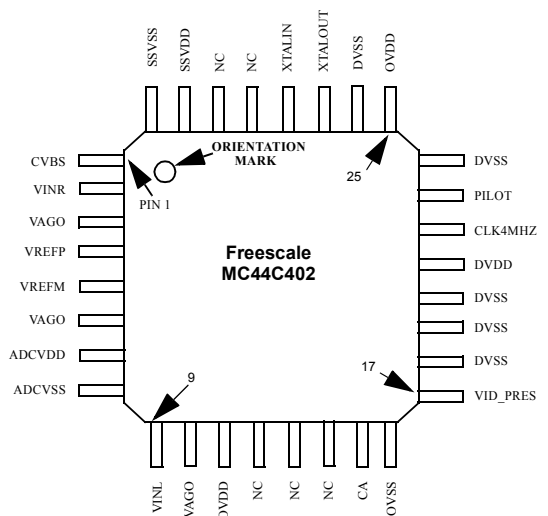

MC44C402 32LQFP Package

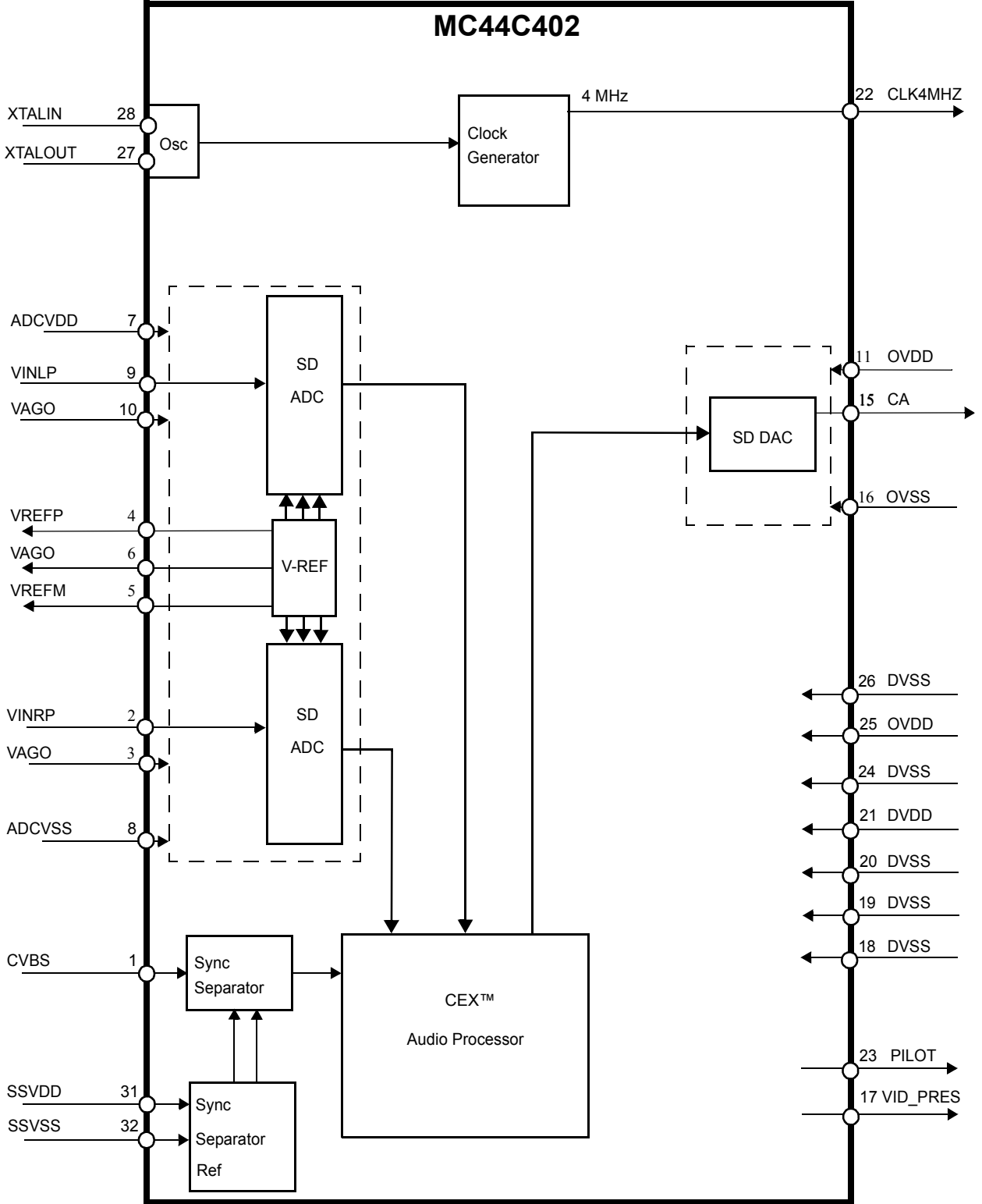

Figure 1. MC44C402 Block Diagram

PIN DESCRIPTION

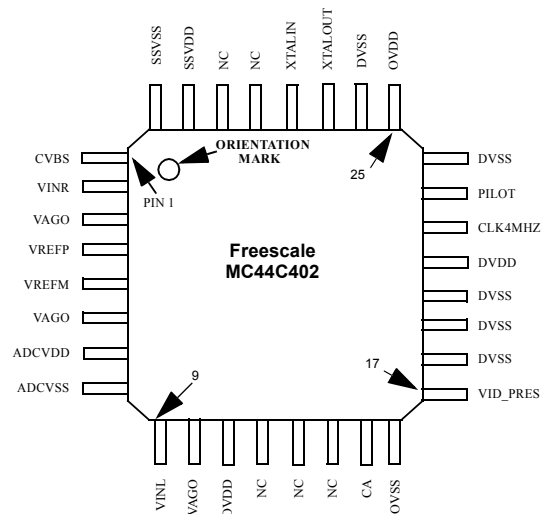

Figure 2. MC44C402 32LQFP Package

Table 1. Pin Descriptions (Listed by Function)

| Signal Name | Pin # | Description |
|---------------------|------------------------|---|
| Analog | | |
| VINL | 9 | Left channel input |
| VREFP | 4 | ADC Voltage Ref. Bypass plus |
| VAGO | 3, 6, 10 | Analog virtual ground |
| VREFM | 5 | ADC Voltage Ref. Bypass minus |
| VINR | 2 | Right channel input |
| CVBS | 1 | Composite video input to sync separator |
| Digital | | |
| CA | 15 | Composite Audio output |
| VID_PRES | 17 | Video present flag, 0 = no video, hi-z = video present |
| PILOT | 23 | 15.734 KHz square wave output phased locked to incoming video |
| NC | 12, 13, 14, 29, 30 | No Connection |
| Clocks | | |
| XTALIN | 28 | Crystal oscillator input |
| XTALOUT | 27 | Crystal oscillator output |
| CLK4MHZ | 22 | 4 MHz clock output for Audio/Video modulator IC |
| Power Supply | | |
| SSV _{DD} | 31 | Sync Separator analog supply voltage, 3.3 V |
| SSV _{SS} | 32 | Sync Separator analog ground |
| ADCV _{DD} | 7 | ADC analog supply voltage, 3.3 V |
| ADCV _{SS} | 8 | ADC analog ground |
| DV _{DD} | 21 | Digital Logic supply voltage, 1.8 V |
| DV _{SS} | 16, 18, 19, 20, 24, 26 | Digital Logic and I/O grounds |
| OV _{DD} | 11, 25 | I/O supply voltage, 3.3 V |

ELECTRICAL SPECIFICATIONS

Table 2. Absolute Maximum Ratings

Absolute maximum continuous ratings are those maximum values beyond which damage to the device may occur. Exposure to these conditions or conditions beyond those indicated may adversely affect device reliability. Functional operation at absolute-maximum-rated conditions is not implied.

| Characteristic | Symbol | Min | Max | Units |
|--------------------------------|--------------------|------|-------------------------|-------|
| Digital Logic Supply Voltage | DV _{DD} | -0.3 | +2.0 | V |
| Digital Output Supply Voltage | OV _{DD} | -0.3 | +4.0 | V |
| ADC Supply Voltage | ADCV _{DD} | -0.3 | +4.0 | V |
| Sync. Separator Supply Voltage | SSV _{DD} | -0.3 | +4.0 | V |
| Input Voltage | V _{in} | -0.3 | xxV _{DD} + 0.3 | V |
| Storage Temperature Range | T _{stg} | -55 | +150 | °C |

Table 3. General Specifications

| Characteristic | Symbol | Min | Typ | max | Units |
|-----------------------------------|--------|------|-----|-----|-------|
| ESD Protection (Machine Model) | MM | 200 | | | V |
| ESD Protection (Human Body Model) | HBM | 2000 | | | V |
| Latch-Up Immunity | LU | 200 | | | mA |

Table 4. Recommended Operating Conditions

| Characteristic | Symbol | Min | Typ | Max | Units |
|--|-------------------------------------|-------|------|-------|-----------------|
| Digital Logic Supply Voltage | DV _{DD} | +1.62 | +1.8 | +1.98 | V |
| Digital Output Supply Voltage | OV _{DD} | +2.97 | +3.3 | +3.63 | V |
| ADC Supply Voltage | ADCV _{DD} | +2.97 | +3.3 | +3.63 | V |
| Sync. Separator Supply Voltage | SSV _{DD} | +2.97 | +3.3 | +3.63 | V |
| Left/Right Channel Input Level | V _{INL} , V _{INR} | | | 1.8 | V _{pp} |
| Composite Video Input Level (See Figure 8) | CVBS | 0.5 | 1.0 | 2.0 | V _{pp} |
| Ambient Temperature | T _A | -40 | | +85 | °C |

Table 5. DC Characteristics

| Characteristic ⁽¹⁾ | Symbol | Min | Typ | Max | Units |
|------------------------------------|---------------------|------|------|------|-------|
| Digital Logic Supply Current | IDV _{DD} | | 7.5 | 8.5 | mA |
| Digital Output Supply Current | IOV _{DD} | | 2.0 | 8.0 | mA |
| ADC Supply Current | IADCV _{DD} | | 7.0 | 9.0 | mA |
| Sync. Separator Supply Current | ISSV _{DD} | | 2.0 | | mA |
| CLK4MHZ, Clock Output @ I = 0.6 mA | V _{ol} | 2.97 | | | V |
| ADC Voltage Ref. Bypass plus | VREFP | | +2.0 | | V |
| ADC Voltage Ref. Bypass minus | VREFM | | +1.0 | | V |
| ADC Voltage Ref. Ground | VAGO | | +1.5 | | V |
| CLK4MHZ, Clock Output @ I = 0.6 mA | V _{oh} | | | 3.63 | V |

1. Unless otherwise noted; DV_{DD} = 1.8 ± 0.18 Vdc, OV_{DD} = ADCV_{DD} = SSV_{DD} = 3.3 ± 0.33 Vdc, GND = 0 Vdc, -40 ≤ T_A ≤ 85°C.

Table 6. AC Characteristics

| Characteristic ⁽¹⁾ | Symbol | Min | Typ | Max | Units |
|--|-----------------|-----|-----|-------|-----------------|
| Input Impedance (Left/Right Input) | R _{in} | | 75 | | kΩ |
| Composite Audio Output Level ⁽²⁾ | CA | | 1.0 | | V _{pp} |
| Composite Output Level | CA | | | 2.2 | V _{pp} |
| Signal to Noise Ratio ^{(2),(3)} | SNR | 72 | 75 | | dB |
| Total Harmonic Distortion ^{(2),(3)} | THD | | 0.1 | 0.3 | % |
| -1 dB Bandwidth | BW | 20 | | 14500 | Hz |
| Stereo Separation 500 Hz - 5 KHz ⁽⁴⁾ | | | 35 | | dB |
| Stereo Separation 100 Hz - 10 KHz ⁽⁴⁾ | | 30 | 35 | | dB |

1. Unless other wise noted; DV_{DD} = 1.8 ± 0.18 Vdc, OV_{DD} = ADCV_{DD} = SSV_{DD} = 3.3 ± 0.33 Vdc, GND = 0 Vdc, -40 ≤ T_A ≤ 85°C.
2. Test conditions, mono, 1 kHz @ 1.5 V_{pp}
3. Measured in 20 Hz to 13.5 kHz bandwidth
4. Measured -10 dB input level

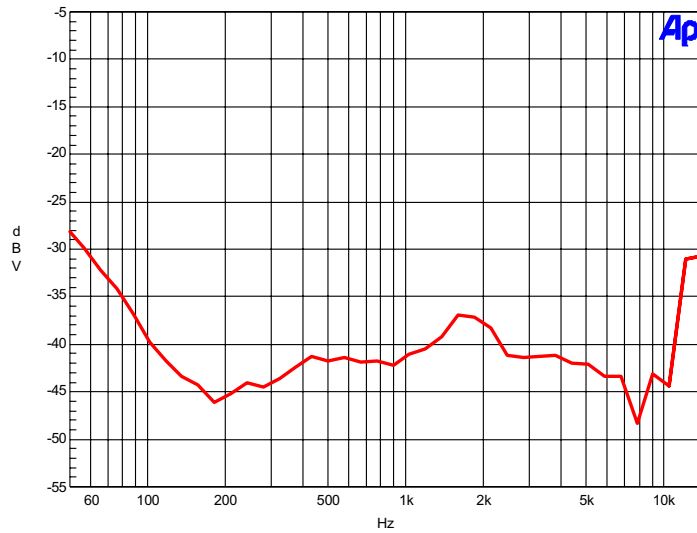

Figure 3. Stereo Separation

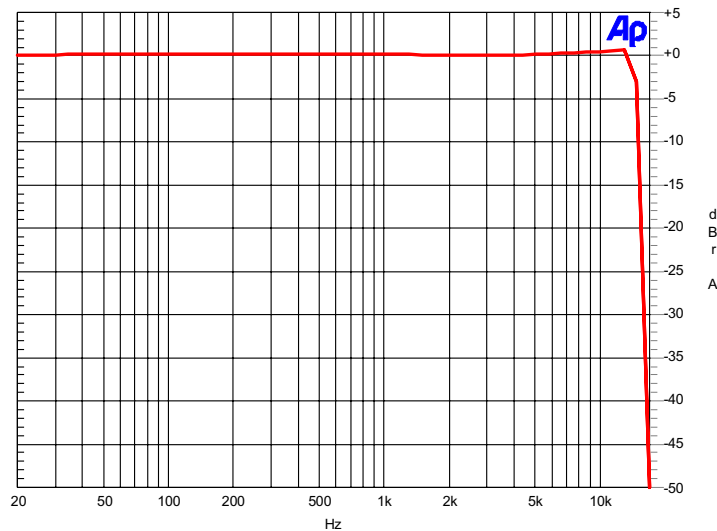

Figure 4. Amplitude Response

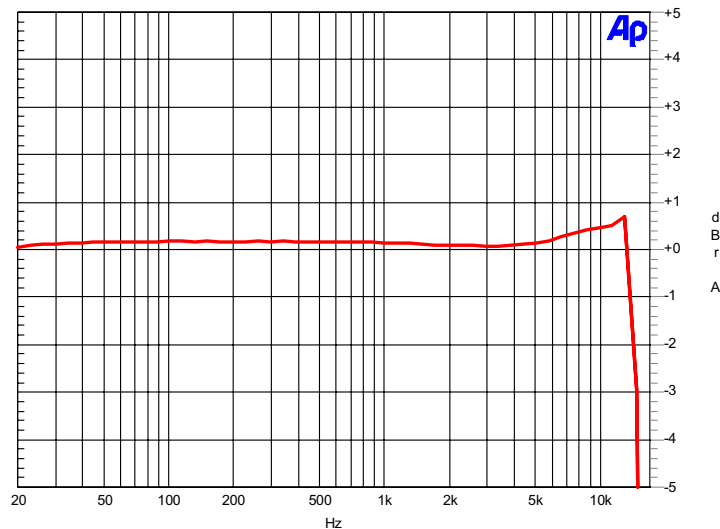

Figure 5. Amplitude Ripple

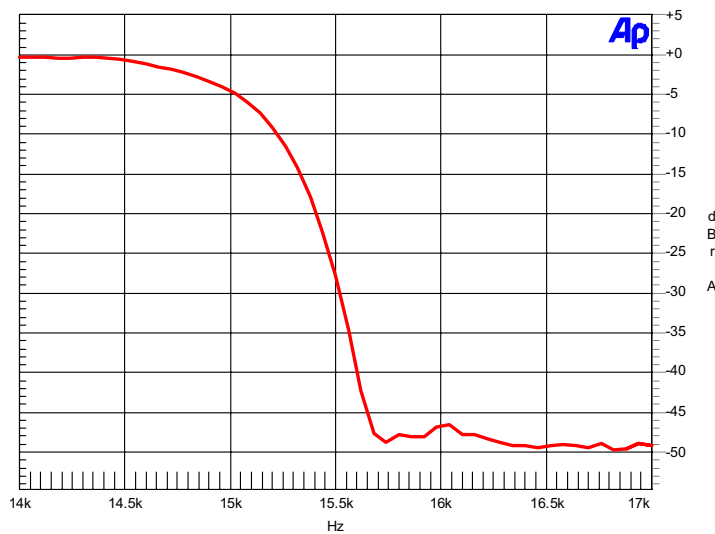

Figure 6. Amplitude-Notch

SYSTEM APPLICATION NOTES

DESIGN CONSIDERATIONS

When developing application using the MC44C402 Stereo Encoder, the user can significantly improve the performance by following the suggestions below:

1. Disable the pre-emphasis on the modulator
2. There must be a 4.5 MHz notch in the video because Video spectra that fall into the 4.5 MHz range will severely impact the audio performance. See the notch filter shown in [Figure 7](#).
3. Measurements must be made with a precision demodulator followed by a precision decoder, measuring audio performance using mono or wide band output will give erroneous results. We suggest the setup as described below
4. A low pass filter is required on the CA (baseband) output. The filter shown in [Figure 7](#) note 1 is recommended. It is a Bessel filter with uniform group delay to 50 kHz and an input impedance of 500Ω and high output impedance.
5. Crystal frequency is critical. It MUST be within +/- 2 kHz (100 PPM) under all conditions. Recommend 30 PPM or better at room temperature. Measure the frequency, being careful not to load the crystal oscillator pins or alternatively the frequency can be determined by measuring the 4 MHz using (spectrum analyzer), being careful not to load the crystal oscillator pins, or with a frequency counter on the 4 MHz port to +/- 400 Hz max or 100 Hz at room temp. A symptom of the crystal being off frequency is stereo separation changing at about a 1 Hz rate (Pulsing).

Equipment suggestions

| | | |
|--------------|---------------------|--------|
| Demodulator: | Tektronix | TV1450 |
| Decoder: | Modulation Sciences | SRD-1 |

MC44C402

MODULATOR INTERFACE

1. The 4 MHz clock drive to the MC44BS373 must be filtered and the level set correctly. This can be achieved simply by using a 1 μ H inductor and 1500 pF and series 750 ohm resistor and 100 pF blocking cap, as shown in Figure 7 note 2.
2. The MC44BS373 SPLL filter must be changed to a single 2.2 μ F capacitor to ground. Please see Figure 7 note 3. (note some caps exhibit microphonic problems in this application).
3. Input impedance of the MC44BS373 is around 70 Kohms and to preserve the low frequency performance the coupling caps should be greater than 0.1 μ F

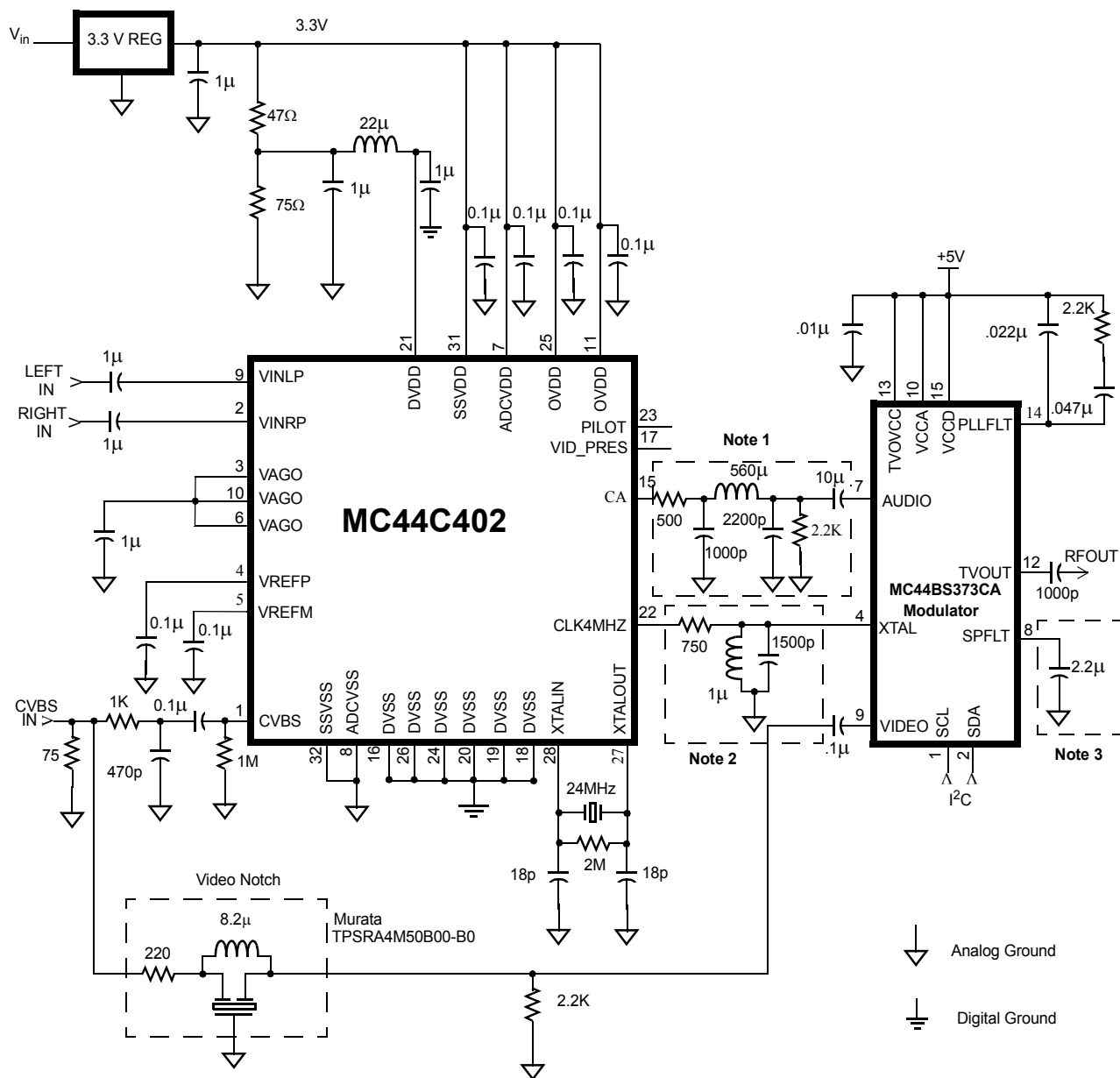

Figure 7. MC44C402 Typical Application Circuit

SETTING LEVEL FOR MODULATOR/ENCODER INTERFACE

1. Verify calibration of the equipment. This requires a modulator and precision signal source. The audio signal cannot be passed through the stereo encoder for this setup. Suggest using 10396.48 Hz audio test signal directly into first Bessel null on a spectrum analyzer.

The null will occur at precisely 25 KHz deviation of the 10396.48 Hz audio test signal. Please see [Figure 8](#) for test equipment setup.

2. Input 1800 Hz @ 0.4 V p-p into left channel and set adjust attenuation between stereo encoder and the modulator for optimum separation using calibrated demodulator and decoder.

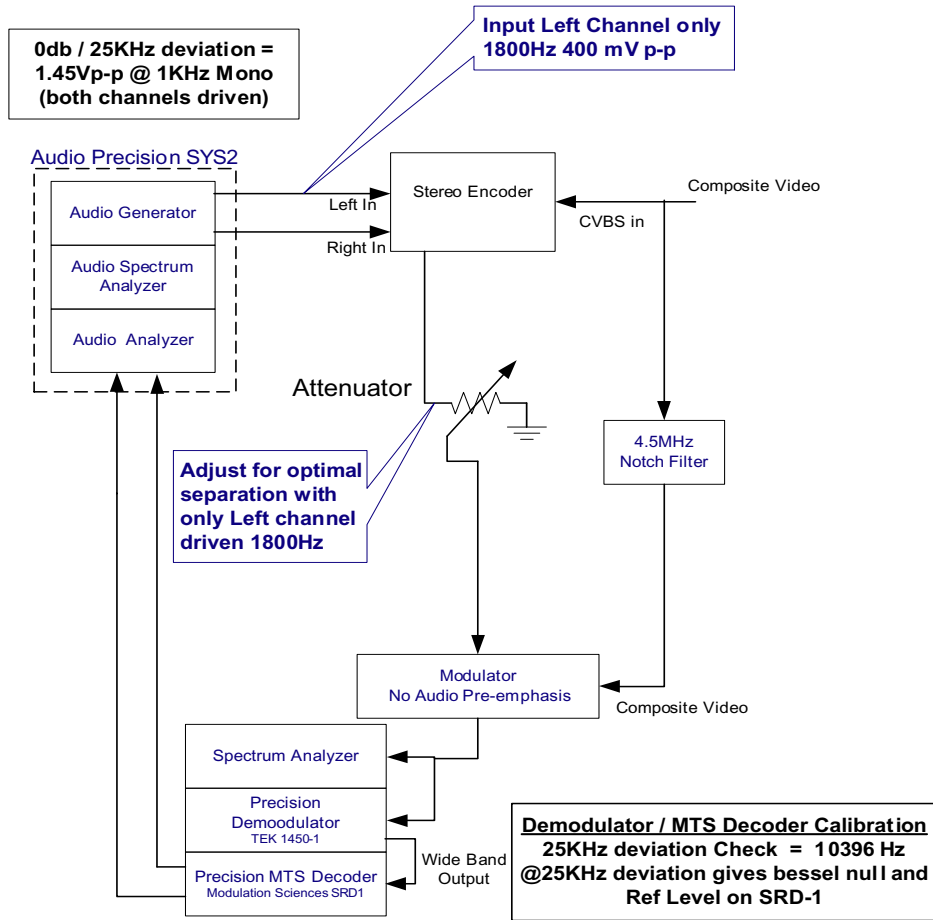

- 1) Calibrate MTS Decoder to Demodulator connection using Bessel Null Technique
- 2) input 1.8KHz 0.4 V p-p on left channel only and optimize stereo separation with attenuator.

Figure 8. MC44C402 Level Setup

PACKAGE DATA

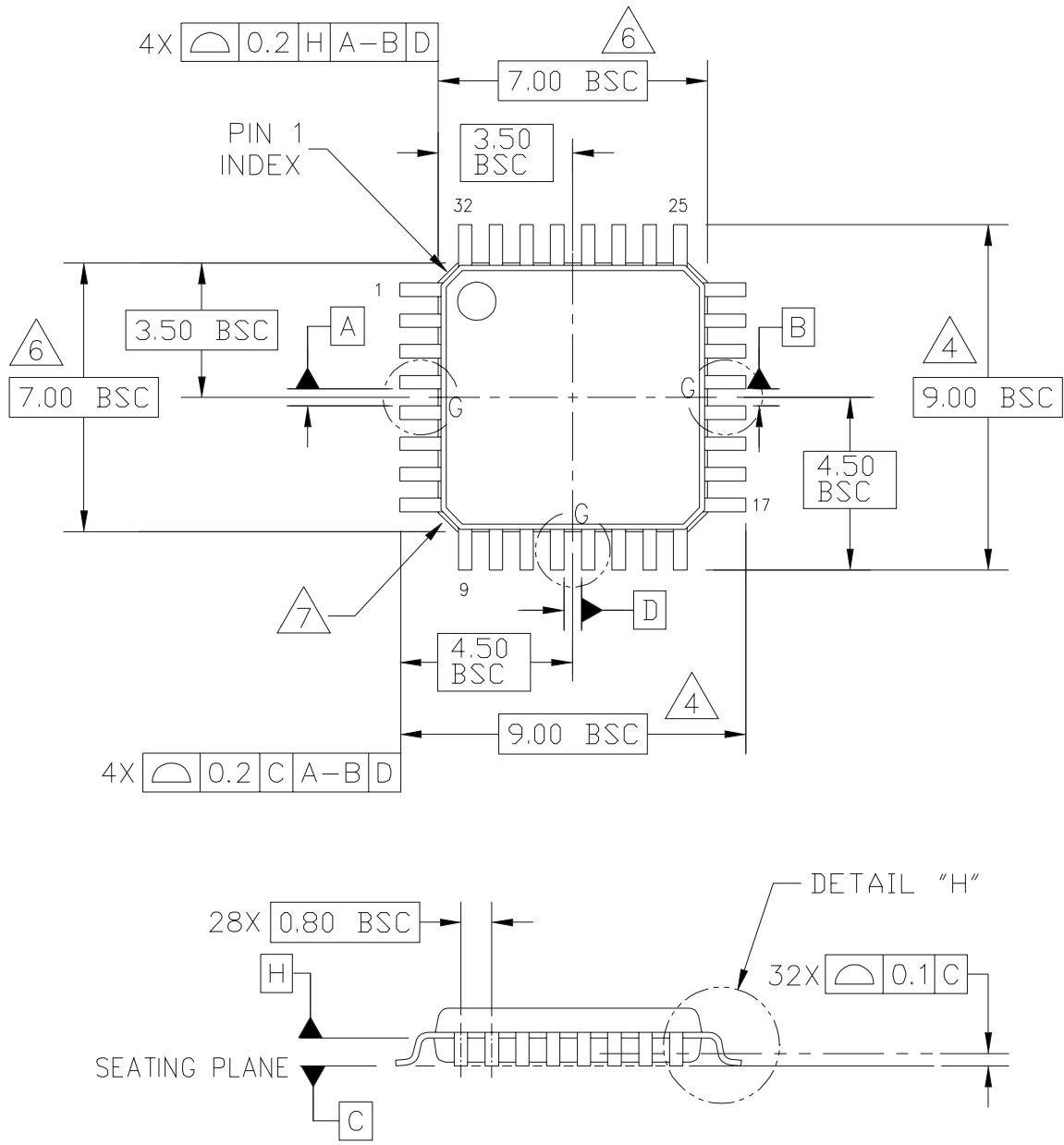

| | | | |
|---|----------------------------|----------------------------|--|
| © FREESCALE SEMICONDUCTOR, INC. ALL RIGHTS RESERVED. | MECHANICAL OUTLINE | PRINT VERSION NOT TO SCALE | |
| TITLE: LOW PROFILE QUAD FLAT PACK (LQFP) 32 LEAD, 0.8 PITCH (7 X 7 X 1.4) | DOCUMENT NO: 98ASH70029A | REV: C | |
| | CASE NUMBER: 873A-04 | 01 APR 2005 | |
| | STANDARD: JEDEC MS-026 BBA | | |

Figure 9. 32QLFP Package Mechanical Data

PACKAGE DATA

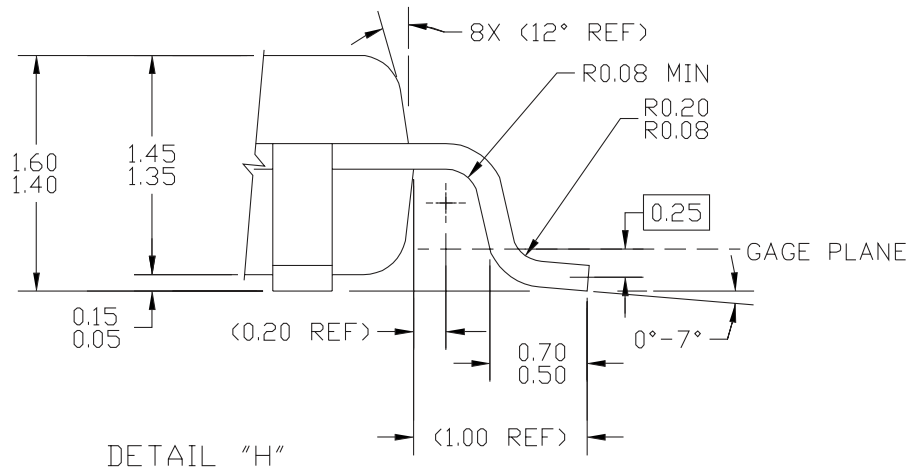
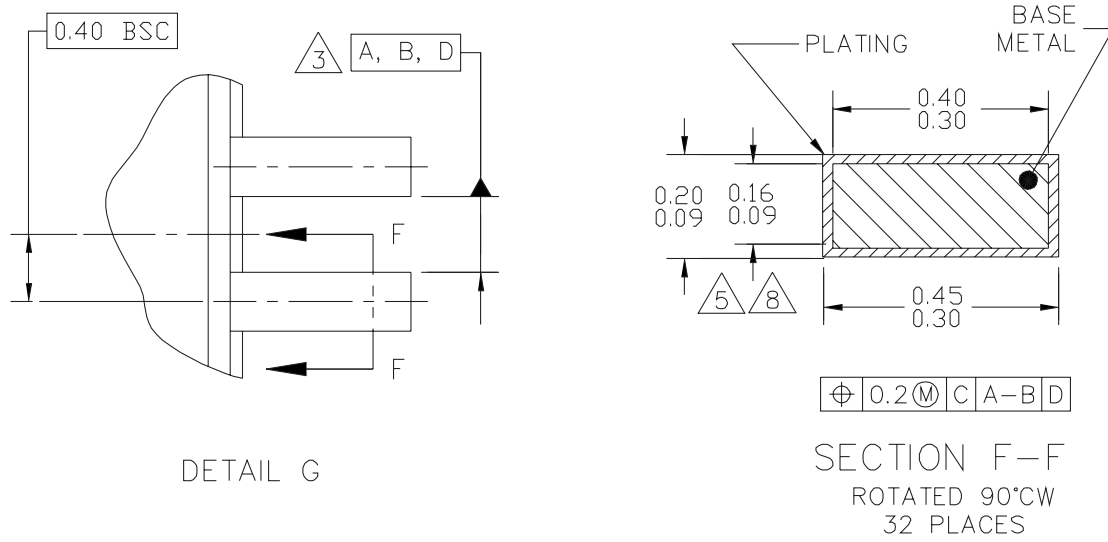

| | | |
|---|----------------------------|----------------------------|
| © FREESCALE SEMICONDUCTOR, INC. ALL RIGHTS RESERVED. | MECHANICAL OUTLINE | PRINT VERSION NOT TO SCALE |
| TITLE: LOW PROFILE QUAD FLAT PACK (LQFP) 32 LEAD, 0.8 PITCH (7 X 7 X 1.4) | DOCUMENT NO: 98ASH70029A | REV: C |
| | CASE NUMBER: 873A-04 | 01 APR 2005 |
| | STANDARD: JEDEC MS-026 BBA | |

Figure 9. 32QLFP Package Mechanical Data (continued)

PACKAGE DATA

NOTES:

1. DIMENSIONS ARE IN MILLIMETERS.
2. INTERPRET DIMENSIONS AND TOLERANCES PER ASME Y14.5-1994.
3. DATUMS A, B, AND D TO BE DETERMINED AT DATUM PLANE H.
4. DIMENSIONS TO BE DETERMINED AT SEATING PLANE DATUM C.
5. DIMENSION DOES NOT INCLUDE DAMBAR PROTRUSION. ALLOWABLE DAMBAR PROTRUSION SHALL NOT CAUSE THE LEAD WIDTH TO EXCEED THE MAXIMUM DIMENSION BY MORE THAN 0.08 MM. DAMBAR CANNOT BE LOCATED ON THE LOWER RADIUS OR THE FOOT. MINIMUM SPACE BETWEEN PROTRUSION AND ADJACENT LEAD OR PROTRUSION: 0.07 MM.
6. DIMENSIONS DO NOT INCLUDE MOLD PROTRUSION. ALLOWABLE PROTRUSION IS 0.25 MM PER SIDE. DIMENSIONS ARE MAXIMUM PLASTIC BODY SIZE DIMENSIONS INCLUDING MOLD MISMATCH.
7. EXACT SHAPE OF EACH CORNER IS OPTIONAL.
8. THESE DIMENSIONS APPLY TO THE FLAT SECTION OF THE LEAD BETWEEN 0.1 MM AND 0.25 MM FROM THE LEAD TIP.

| | | |
|---|----------------------------|----------------------------|
| © FREESCALE SEMICONDUCTOR, INC. ALL RIGHTS RESERVED. | MECHANICAL OUTLINE | PRINT VERSION NOT TO SCALE |
| TITLE: LOW PROFILE QUAD FLAT PACK (LQFP) 32 LEAD, 0.8 PITCH (7 X 7 X 1.4) | DOCUMENT NO: 98ASH70029A | REV: C |
| | CASE NUMBER: 873A-04 | 01 APR 2005 |
| | STANDARD: JEDEC MS-026 BBA | |

PAGE 3 OF 3

Figure 9. 32QLFP Package Mechanical Data (continued)

How to Reach Us:

Home Page:

www.freescale.com

E-mail:

support@freescale.com

USA/Europe or Locations Not Listed:

Freescale Semiconductor
Technical Information Center, CH370
1300 N. Alma School Road
Chandler, Arizona 85224
+1-800-521-6274 or +1-480-768-2130
support@freescale.com

Europe, Middle East, and Africa:

Freescale Halbleiter Deutschland GmbH
Technical Information Center
Schatzbogen 7
81829 Muenchen, Germany
+44 1296 380 456 (English)
+46 8 52200080 (English)
+49 89 92103 559 (German)
+33 1 69 35 48 48 (French)
support@freescale.com

Japan:

Freescale Semiconductor Japan Ltd.
Headquarters
ARCO Tower 15F
1-8-1, Shimo-Meguro, Meguro-ku,
Tokyo 153-0064
Japan
0120 191014 or +81 3 5437 9125
support.japan@freescale.com

Asia/Pacific:

Freescale Semiconductor Hong Kong Ltd.
Technical Information Center
2 Dai King Street
Tai Po Industrial Estate
Tai Po, N.T., Hong Kong
+800 2666 8080
support.asia@freescale.com

For Literature Requests Only:

Freescale Semiconductor Literature Distribution Center
P.O. Box 5405
Denver, Colorado 80217
1-800-441-2447 or 303-675-2140
Fax: 303-675-2150
LDCForFreescaleSemiconductor@hibbertgroup.com

Information in this document is provided solely to enable system and software implementers to use Freescale Semiconductor products. There are no express or implied copyright licenses granted hereunder to design or fabricate any integrated circuits or integrated circuits based on the information in this document.

Freescale Semiconductor reserves the right to make changes without further notice to any products herein. Freescale Semiconductor makes no warranty, representation or guarantee regarding the suitability of its products for any particular purpose, nor does Freescale Semiconductor assume any liability arising out of the application or use of any product or circuit, and specifically disclaims any and all liability, including without limitation consequential or incidental damages. "Typical" parameters that may be provided in Freescale Semiconductor data sheets and/or specifications can and do vary in different applications and actual performance may vary over time. All operating parameters, including "Typicals", must be validated for each customer application by customer's technical experts. Freescale Semiconductor does not convey any license under its patent rights nor the rights of others. Freescale Semiconductor products are not designed, intended, or authorized for use as components in systems intended for surgical implant into the body, or other applications intended to support or sustain life, or for any other application in which the failure of the Freescale Semiconductor product could create a situation where personal injury or death may occur. Should Buyer purchase or use Freescale Semiconductor products for any such unintended or unauthorized application, Buyer shall indemnify and hold Freescale Semiconductor and its officers, employees, subsidiaries, affiliates, and distributors harmless against all claims, costs, damages, and expenses, and reasonable attorney fees arising out of, directly or indirectly, any claim of personal injury or death associated with such unintended or unauthorized use, even if such claim alleges that Freescale Semiconductor was negligent regarding the design or manufacture of the part.

Freescale™ and the Freescale logo are trademarks of Freescale Semiconductor, Inc. All other product or service names are the property of their respective owners.

© Freescale Semiconductor, Inc. 2005. All rights reserved.