

# THVD1424 3-V to 5.5-V RS-485 Transceiver With Slew Rate Control, Integrated 120-Ohm Switchable Termination Resistor and Duplex Switching

## 1 Features

- Meets or exceeds the requirements of the TIA/EIA-485A standard
- 3-V to 5.5-V bus supply voltage
- 1.65 V to 5.5 V supply for logic signals
- Differential output exceeds 2.1 V for PROFIBUS compatibility with 5-V supply
- Pin configurable Half-duplex and full-duplex
- Pin controlled on-chip 120  $\Omega$  termination resistor on bus pins
- Maximum Data rate configurable
  - SLR = High: 500 kbps
  - SLR = Low or floating: 20 Mbps
- Bus I/O protection
  - $\pm 16$ -kV HBM ESD
  - $\pm 8$ -kV IEC 61000-4-2 Contact discharge
  - $\pm 15$ -kV IEC 61000-4-2 Air gap discharge
  - $\pm 4$ -kV IEC 61000-4-4 Fast transient burst
  - $\pm 16$ -V bus fault protection (absolute max voltage on bus pins)
- Extended industrial temperature range:  $-40^{\circ}\text{C}$  to  $125^{\circ}\text{C}$
- Low power consumption
  - Shutdown supply current  $< 5 \mu\text{A}$
  - Quiescent current during operation  $< 3 \text{ mA}$
- Glitch-free power-up/power-down for hot plug-in capability
- Open, short, and idle bus failsafe
- Small, space-saving 16-VQFN (3 mm x 3 mm) package

## 2 Applications

- [Factory automation & control](#)
- [Building automation](#)
- [Industrial transport](#)
- [HVAC systems](#)
- [Smart meters](#)
- [Lighting](#)
- [Grid Infrastructure](#)

## 3 Description

The THVD1424 is a flexible RS-485 transceiver for industrial applications. The device has features such as on-chip 120- $\Omega$  termination resistor, slew rate control and interchangeability between half and full duplex mode. All the features are pin-controlled. This enables the device to be used at any node location (end nodes or middle nodes) in any network, two-wire (half duplex) or 4-wire (full duplex), slow or fast. End-equipment designers can now design a common printed circuit board (PCB) and configure it via software for various application needs. This can save considerable design and qualification time for the customers.

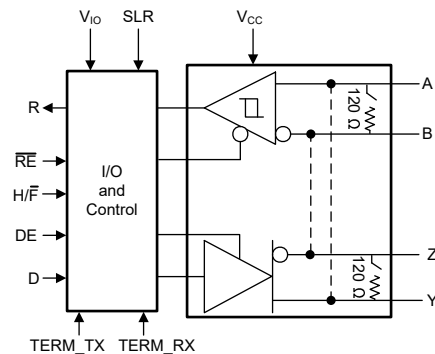
The bus pins are immune to high levels of IEC Contact Discharge ESD events, eliminating the need for additional system level protection components. The device operates from 3 to 5.5-V bus supply, while the logic supply voltage range is 1.65 V to 5.5 V. The wide common-mode voltage range and low input leakage on bus pins makes the devices suitable for multi-point applications over long cable runs.

The device is available in a space-saving, thermally efficient 16-pin VQFN package. The device is characterized for ambient temperatures from  $-40^{\circ}\text{C}$  to  $125^{\circ}\text{C}$ .

### Package Information

PART NUMBER	PACKAGE <sup>(1)</sup>	BODY SIZE (NOM)
THVD1424	VQFN (16)	3 mm x 3 mm

(1) For the complete part number, see the orderable addendum at the end of the data sheet.



**Simplified Schematic**



## Table of Contents

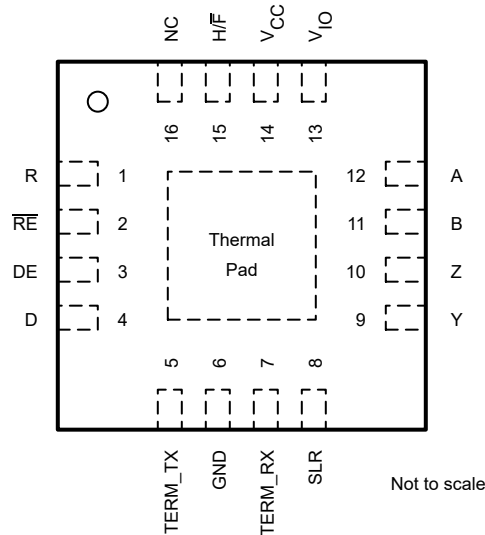
<b>1 Features</b> .....	<b>1</b>	<b>8 Detailed Description</b> .....	<b>15</b>
<b>2 Applications</b> .....	<b>1</b>	8.1 Overview.....	15
<b>3 Description</b> .....	<b>1</b>	8.2 Functional Block Diagrams.....	15
<b>4 Revision History</b> .....	<b>2</b>	8.3 Feature Description.....	15
<b>5 Pin Configuration and Functions</b> .....	<b>3</b>	8.4 Device Functional Modes.....	15
<b>6 Specifications</b> .....	<b>4</b>	<b>9 Application Information Disclaimer</b> .....	<b>19</b>
6.1 Absolute Maximum Ratings.....	4	9.1 Application Information.....	19
6.2 ESD Ratings .....	4	9.2 Typical Application.....	19
6.3 ESD Ratings [IEC].....	4	9.3 Power Supply Recommendations.....	26
6.4 Recommended Operating Conditions.....	5	9.4 Layout.....	26
6.5 Thermal Information.....	5	<b>10 Device and Documentation Support</b> .....	<b>28</b>
6.6 Power Dissipation.....	5	10.1 Device Support.....	28
6.7 Electrical Characteristics.....	6	10.2 Receiving Notification of Documentation Updates..	28
6.8 Switching Characteristics_500 kbps.....	8	10.3 Support Resources.....	28
6.9 Switching Characteristics_20 Mbps.....	8	10.4 Trademarks.....	28
6.10 Switching Characteristics_Termination resistor.....	9	10.5 Electrostatic Discharge Caution.....	28
6.11 Switching Characteristics_Duplex switching.....	9	10.6 Glossary.....	28
6.12 Typical Characteristics.....	10	<b>11 Mechanical, Packaging, and Orderable Information</b> .....	<b>28</b>
<b>7 Parameter Measurement Information</b> .....	<b>12</b>		

## 4 Revision History

NOTE: Page numbers for previous revisions may differ from page numbers in the current version.

Changes from Revision * (September 2022) to Revision A (March 2023)	Page
• Changed <a href="#">Figure 9-2</a> .....	19

## 5 Pin Configuration and Functions



**Figure 5-1. VQFN (RGT) Package, 16-Pins  
(Top View)**

**Table 5-1. Pin Functions**

PIN		TYPE	DESCRIPTION
NAME	NO.		
R	1	Digital output	Logic output RS485 data
RE	2	Digital input	Receiver enable/disable. Internal pull-up. Receiver disabled by default
DE	3	Digital input	Driver enable/disable. Internal pull-down. Driver disabled by default
D	4	Digital input	Logic input RS485 data. Internal pull-up. Drives the bus high by default if driver is enabled
TERM_TX	5	Digital input	120 $\Omega$ on-chip termination control for Y/Z pins. Internal pull-down. Termination across Y/Z is disabled by default
GND	6	GND	Ground
TERM_RX	7	Digital input	120 $\Omega$ on-chip termination control for A/B pins. Internal pull-down. Termination across A/B is disabled by default
SLR	8	Digital input	Slew rate control. Internal pull-down, default 20 Mbps operation. Logic high SLR enables slow speed (500 kbps)
Y	9	Bus input/output	RS485 bus pins. In full duplex, this pin is non-inverting driver output. In half duplex, this is non-inverting driver output and non-inverting receiver input
Z	10	Bus input/output	RS485 bus pins. In full duplex, this pin is inverting driver output. In half duplex, this is inverting driver output and inverting receiver input
B	11	Bus input	RS485 receiver inverting input pin in full duplex mode
A	12	Bus input	RS485 receiver non-inverting input pin in full duplex mode
V <sub>IO</sub>	13	Supply	1.65 to 5.5 V logic supply voltage
V <sub>CC</sub>	14	Supply	3 to 5.5V supply voltage
H/F	15	Digital input	Half to full duplex control. Internal pull-down, so full duplex by default- Y/Z are driver output, A/B are receiver input pins
NC	16	No connect	Not connected internally
Thermal pad		--	Connect to GND for optimal thermal and electrical performance

## 6 Specifications

### 6.1 Absolute Maximum Ratings

over operating free-air temperature range (unless otherwise noted) <sup>(1)</sup> <sup>(2)</sup>

		MIN	MAX	UNIT
Bus supply voltage	$V_{CC}$	-0.5	7	V
Logic supply voltage	$V_{IO}$	-0.5	$V_{CC} + 0.2$	V
Bus voltage	Voltage at any bus pin (Y, Z, A or B) with respect to GND	-16	16	V
Differential bus voltage	(Y-Z) or (Z-Y), (A-B) or (B-A) with termination enabled	-6	6	V
Input voltage	Range at any logic pin (D, DE, SLR, TERM_TX, TERM_RX, H/F or RE)	-0.3	$V_{IO} + 0.2$	V
Receiver output current	$I_O$	-24	24	mA
Storage temperature	$T_{stg}$	-65	150	°C

- (1) Operation outside the Absolute Maximum Ratings may cause permanent device damage. Absolute Maximum Ratings do not imply functional operation of the device at these or any other conditions beyond those listed under Recommended Operating Conditions. If used outside the Recommended Operating Conditions but within the Absolute Maximum Ratings, the device may not be fully functional, and this may affect device reliability, functionality, performance, and shorten the device lifetime.
- (2) All voltage values, except differential I/O bus voltages, are with respect to ground terminal.

### 6.2 ESD Ratings

			VALUE	UNIT	
$V_{(ESD)}$	Electrostatic discharge	Human-body model (HBM), per ANSI/ESDA/JEDEC JS-001 <sup>(1)</sup>	Bus terminals (Y, Z, A, B) and GND	±16,000	V
			All pins except bus terminals and GND	±4,000	V
		Charged-device model (CDM), per JEDEC specification JESD22-C101 <sup>(2)</sup>	±1,500	V	

- (1) JEDEC document JEP155 states that 500-V HBM allows safe manufacturing with a standard ESD control process.
- (2) JEDEC document JEP157 states that 250-V CDM allows safe manufacturing with a standard ESD control process.

### 6.3 ESD Ratings [IEC]

				VALUE	UNIT
$V_{(ESD)}$	Electrostatic discharge, Device configured as either half duplex or Full duplex, on chip termination ON or OFF	Contact discharge, per IEC 61000-4-2	Bus terminals and GND	±8,000	V
		Air-gap discharge, per IEC 61000-4-2	Bus terminals and GND	±15,000	
$V_{(EFT)}$	Electrical fast transient	Per IEC 61000-4-4	Bus terminals	±4,000	V

## 6.4 Recommended Operating Conditions

over operating free-air temperature range (unless otherwise noted)

		MIN	NOM	MAX	UNIT
V <sub>CC</sub>	Supply voltage	3		5.5	V
V <sub>IO</sub>	I/O supply voltage	1.65		V <sub>CC</sub>	V
V <sub>I</sub>	Input voltage at any bus terminal (separately or common mode) <sup>(1)</sup>	-7		12	V
V <sub>IH</sub>	High-level input voltage (D, DE, RE, TERM_TX, TERM_RX, SLR, H/F inputs)	0.7*V <sub>IO</sub>		V <sub>IO</sub>	V
V <sub>IL</sub>	Low-level input voltage (D, DE, RE, TERM_TX, TERM_RX, SLR, H/F inputs)	0		0.3*V <sub>IO</sub>	V
I <sub>O</sub>	Output current, driver	-60		60	mA
I <sub>OR</sub>	Output current, receiver	V <sub>IO</sub> = 1.8 V or 2.5 V		4	mA
I <sub>OR</sub>	Output current, receiver	V <sub>IO</sub> = 3.3 V or 5 V		8	mA
R <sub>L</sub>	Differential load resistance	54	60		Ω
1/t <sub>UI</sub>	Signaling rate	SLR = V <sub>IO</sub>		500	kbps
		SLR = GND or floating		20	Mbps
T <sub>A</sub> <sup>(2)</sup>	Operating ambient temperature	-40		125	°C
T <sub>J</sub> <sup>(2)</sup>	Junction temperature	-40		150	°C

- (1) The algebraic convention, in which the least positive (most negative) limit is designated as minimum is used in this data sheet.  
(2) Operation is specified for internal (junction) temperatures up to 150°C. Self-heating due to internal power dissipation should be considered for each application. Maximum junction temperature is internally limited by the thermal shut-down (TSD) circuit which disables the driver and receiver when the junction temperature reaches typical 170°C.

## 6.5 Thermal Information

THERMAL METRIC <sup>(1)</sup>		THVD1424		UNIT
		RGT (QFN)		
		16 PINS		
R <sub>θJA</sub>	Junction-to-ambient thermal resistance	46.1		°C/W
R <sub>θJC(top)</sub>	Junction-to-case (top) thermal resistance	50.9		°C/W
R <sub>θJB</sub>	Junction-to-board thermal resistance	20.6		°C/W
ψ <sub>JT</sub>	Junction-to-top characterization parameter	1.1		°C/W
ψ <sub>JB</sub>	Junction-to-board characterization parameter	20.6		°C/W
R <sub>θJC(bot)</sub>	Junction-to-case (bottom) thermal resistance	6.9		°C/W

- (1) For more information about traditional and new thermal metrics, see the [yes](#) application report.

## 6.6 Power Dissipation

PARAMETER		TEST CONDITIONS			Typical	Max	UNIT
P <sub>D</sub>	Driver and receiver enabled, external loopback by A connected to Y, B connected to Z V <sub>IO</sub> = V <sub>CC</sub> = 5.5 V, T <sub>A</sub> = 125 °C, D = square wave 50% duty	Unterminated, TERM_TX = L, TERM_RX = L	SLR = H	500 kbps	185	210	mW
			SLR = L	20Mbps	310	340	
		TERM_RX = H, With 120 Ω load between A/B inputs	SLR = H	500 kbps	316	360	mW
			SLR = L	20Mbps	396	430	
		TERM_TX = TERM_RX = H; With 120 Ω between Y/Z outputs and A/B inputs, C <sub>L</sub> = 50 pF (driver)	SLR = H	500 kbps	407	470	mW
			SLR = L	20Mbps	476	510	

## 6.7 Electrical Characteristics

over operating free-air temperature range (unless otherwise noted). All typical values are at 25°C and supply voltage of  $V_{CC} = 5\text{ V}$ ,  $V_{IO} = 3.3\text{ V}$ , unless otherwise noted.

PARAMETER		TEST CONDITIONS		MIN	TYP	MAX	UNIT
<b>Driver</b>							
$ V_{OD} $	Driver differential output voltage magnitude	$R_L = 60\ \Omega$ , $-7\text{ V} \leq V_{\text{test}} \leq 12\text{ V}$ (See Figure 7-1)		1.5	3.3		V
		$R_L = 60\ \Omega$ , $-7\text{ V} \leq V_{\text{test}} \leq 12\text{ V}$ , $4.5\text{ V} \leq V_{CC} \leq 5.5\text{ V}$ (See Figure 7-1)		2.1	3.3		V
		$R_L = 100\ \Omega$ (See Figure 7-2)		2	4		V
		$R_L = 54\ \Omega$ , $4.5\text{ V} \leq V_{CC} \leq 5.5\text{ V}$ (See Figure 7-2)		2.1	3.3		V
		$R_L = 54\ \Omega$ (See Figure 7-2)		1.5	3.3		V
$\Delta V_{OD} $	Change in magnitude of differential output voltage	$R_L = 54\ \Omega$ or $100\ \Omega$ (See Figure 7-2)		-50		50	mV
$V_{OC}$	Common-mode output voltage	$R_L = 54\ \Omega$ or $100\ \Omega$ (See Figure 7-2)			$V_{CC}/2$	3	V
$\Delta V_{OC(SS)}$	Change in steady-state common-mode output voltage	$R_L = 54\ \Omega$ or $100\ \Omega$ (See Figure 7-2)		-50		50	mV
$I_{OS}$	Short-circuit output current	DE = $V_{IO}$ , $-7\text{ V} \leq (V_Y \text{ or } V_Z) \leq 12\text{ V}$ , or Y shorted to Z		-250		250	mA
$I_{OZD}$	Driver High impedance output leakage current on Y an Z in Full duplex mode	$H/F = \text{GND}$ , TERM_TX = GND, DE = GND, $V_{CC} = \text{GND}$ or 5.5V, $V_O = -7\text{V}$ , +12V		-100		110	$\mu\text{A}$
		$H/F = \text{GND}$ , TERM_TX = $V_{IO}$ , DE = GND, $V_{CC} = 5.5\text{V}$ , $V_O = -7\text{V}$ , +12V		-300		300	$\mu\text{A}$
<b>Receiver</b>							
$I_I$	Bus input current (termination disabled)	DE = 0 V, $V_{CC}$ and $V_{IO} = 0\text{ V}$ or 5.5 V		$V_I = 12\text{ V}$	85	110	$\mu\text{A}$
				$V_I = -7\text{ V}$	-100	-70	$\mu\text{A}$
$I_{RXT}$	Receiver bus input leakage current with termination enabled	DE = 0 V, $V_{CC}$ and $V_{IO} = 5.5\text{ V}$ , TERM_RX = $V_{IO}$		$V_I = -7\text{ to }12\text{ V}$		-300	300 $\mu\text{A}$
$V_{TH+}$	Positive-going input threshold voltage <sup>(1)</sup>	Over common-mode range of -7 V to 12 V			-85	-45	mV
$V_{TH-}$	Negative-going input threshold voltage <sup>(1)</sup>			-200	-135	mV	
$V_{HYS}$	Input hysteresis			30	50	mV	
$C_{A,B}$	Input differential capacitance	Measured between A and B, $f = 1\text{ MHz}$			20		pF
$V_{OH}$	Output high voltage	$I_{OH} = -8\text{ mA}$ , $V_{IO} = 3\text{ to }3.6\text{ V}$ or 4.5 V to 5.5 V		$V_{IO} - 0.4$ $V_{IO} - 0.2$			V
$V_{OL}$	Output low voltage	$I_{OL} = 8\text{ mA}$ , $V_{IO} = 3\text{ to }3.6\text{ V}$ or 4.5 V to 5.5 V		0.2		0.4	V
$V_{OH}$	Output high voltage	$I_{OH} = -4\text{ mA}$ , $V_{IO} = 1.65\text{ to }1.95\text{ V}$ or 2.25 V to 2.75 V		$V_{IO} - 0.4$ $V_{IO} - 0.2$			V
$V_{OL}$	Output low voltage	$I_{OL} = 4\text{ mA}$ , $V_{IO} = 1.65\text{ to }1.95\text{ V}$ or 2.25 V to 2.75 V		0.2		0.4	V
$I_{OZ}$	Output high-impedance current, R pin	$V_O = 0\text{ V}$ or $V_{IO}$ , RE = $V_{IO}$		-2		2	$\mu\text{A}$
<b>Logic</b>							
$I_{IN}$	Input current (D, RE, DE, SLR, TERM_TX, TERM_RX, H/F)	$1.65\text{ V} \leq V_{IO} \leq 5.5\text{ V}$ , $0\text{ V} \leq V_{IN} \leq V_{IO}$		-5		5	$\mu\text{A}$
<b>Thermal Protection</b>							
$T_{SHDN}$	Thermal shutdown threshold	Temperature rising		150	170		°C
$T_{HYS}$	Thermal shutdown hysteresis				15		°C
<b>Supply</b>							
$UV_{VCC}$ (rising)	Rising under-voltage threshold on $V_{CC}$				2.5	2.7	V
$UV_{VCC}$ (falling)	Falling under-voltage threshold on $V_{CC}$			2	2.1		V
$UV_{VCC(hys)}$	Hysteresis on under-voltage of $V_{CC}$				400		mV
$UV_{VIO}$ (rising)	Rising under-voltage threshold on $V_{IO}$				1.5	1.6	V

## 6.7 Electrical Characteristics (continued)

over operating free-air temperature range (unless otherwise noted). All typical values are at 25°C and supply voltage of  $V_{CC} = 5\text{ V}$ ,  $V_{IO} = 3.3\text{ V}$ , unless otherwise noted.

PARAMETER		TEST CONDITIONS		MIN	TYP	MAX	UNIT
$UV_{V_{IO}}$ (falling)	Falling under-voltage threshold on $V_{IO}$			1.3	1.4		V
$UV_{V_{IO}(hys)}$	Hysteresis on under-voltage of $V_{IO}$				100		mV
$I_{CC}$	Supply current (quiescent), $V_{CC} = 4.5\text{ V to }5.5\text{ V}$ TERM_RX, TERM_TX= Floating or low, SLR = X	Driver and receiver enabled, $H/\bar{F} = \text{GND}$	$\bar{R}E = 0\text{ V}$ , $DE = V_{IO}$ , No load		1.5	3	mA
		Driver enabled, receiver disabled, $H/\bar{F} = \text{GND}$	$\bar{R}E = V_{IO}$ , $DE = V_{IO}$ , No load		1.3	2.5	mA
		Driver disabled, receiver enabled, $H/\bar{F} = \text{GND}$	$\bar{R}E = 0\text{ V}$ , $DE = 0\text{ V}$ , No load		0.8	1.2	mA
		Driver and receiver disabled, $H/\bar{F} = \text{GND}$	$\bar{R}E = V_{IO}$ , $DE = 0\text{ V}$ , D = open, No load		0.1	2	$\mu\text{A}$
$I_{CC}$	Supply current (quiescent), $V_{CC} = 3\text{ V to }3.6\text{ V}$ TERM_RX, TERM_TX= Floating or low, SLR = X	Driver and receiver enabled, $H/\bar{F} = \text{GND}$	$\bar{R}E = 0\text{ V}$ , $DE = V_{IO}$ , No load		1.4	2	mA
		Driver enabled, receiver disabled, $H/\bar{F} = \text{GND}$	$\bar{R}E = V_{IO}$ , $DE = V_{IO}$ , No load		1	1.5	mA
		Driver disabled, receiver enabled, $H/\bar{F} = \text{GND}$	$\bar{R}E = 0\text{ V}$ , $DE = 0\text{ V}$ , No load		0.7	1	mA
		Driver and receiver disabled, $H/\bar{F} = \text{GND}$	$\bar{R}E = V_{IO}$ , $DE = 0\text{ V}$ , D = open, No load		0.1	2	$\mu\text{A}$
$I_{IO}$	Logic supply current (quiescent), $V_{IO} = 3\text{ to }3.6\text{ V}$ TERM_RX, TERM_TX= Floating or low	Driver disabled, Receiver enabled, SLR = GND	$DE = 0\text{ V}$ , $\bar{R}E = 0\text{ V}$ , No load		6	11	$\mu\text{A}$
		Driver disabled, Receiver enabled, SLR = $V_{IO}$	$DE = 0\text{ V}$ , $\bar{R}E = 0\text{ V}$ , No load		8	11	$\mu\text{A}$
		Driver disabled, Receiver disabled, SLR = GND	$DE = 0\text{ V}$ , $\bar{R}E = V_{IO}$ , No load		2	4	$\mu\text{A}$
		Driver disabled, Receiver disabled, SLR = $V_{IO}$	$DE = 0\text{ V}$ , $\bar{R}E = V_{IO}$ , No load		4	7	$\mu\text{A}$
$I_{CCDT}$	Supply current in driver termination mode	Driver enabled with termination ON, $H/\bar{F} = \text{GND}$	$DE = V_{IO}$ , TERM_TX = $V_{IO}$		39	48	mA
$I_{CCRT}$	Supply current in receiver termination mode	Receiver enabled with termination ON, $H/\bar{F} = \text{GND}$	$RE = \text{GND}$ , TERM_RX = $V_{IO}$		1	1.3	mA
$I_{CCCT}$	Supply current in device disabled, termination ON mode	Driver and receiver disabled, $H/\bar{F} = \text{GND}$	$DE = \text{GND}$ , $\bar{R}E = V_{IO}$ , TERM_RX = $V_{IO}$		200	310	$\mu\text{A}$
<b>On-Chip termination resistor</b>							
$R_{\text{TERM\_TX}}$	120 $\Omega$ termination across Driver output Y/Z terminals	$DE = \text{GND}$ , TERM_TX = $V_{IO}$ , $V_{YZ} = 2\text{ V}$ , $V_Z = -7\text{ V}$ , $0\text{ V}$ , $10\text{ V}$ See <a href="#">Figure 7-9</a>		102	120	138	$\Omega$
$R_{\text{TERM\_RX}}$	120 $\Omega$ termination across receiver output A/B terminals	TERM_RX = $V_{IO}$ , $V_{AB} = 2\text{ V}$ , $V_B = -7\text{ V}$ , $0\text{ V}$ , $10\text{ V}$ See <a href="#">Figure 7-10</a>		102	120	138	$\Omega$

(1) Under any specific conditions,  $V_{\text{TH}+}$  is assured to be at least  $V_{\text{HYS}}$  higher than  $V_{\text{TH}-}$ .

## 6.8 Switching Characteristics\_500 kbps

500-kbps (with SLR = V<sub>IO</sub>) over recommended operating conditions. All typical values are at 25°C and supply voltage of V<sub>CC</sub> = 5 V, V<sub>IO</sub> = 3.3 V, unless otherwise noted. <sup>(1)</sup>

PARAMETER		TEST CONDITIONS		MIN	TYP	MAX	UNIT
<b>Driver</b>							
t <sub>r</sub> , t <sub>f</sub>	Differential output rise/fall time	R <sub>L</sub> = 54 Ω, C <sub>L</sub> = 50 pF See <a href="#">Figure 7-3</a>	V <sub>CC</sub> = 3 to 3.6 V, Typical at 3.3 V	200	250	600	ns
			V <sub>CC</sub> = 4.5 to 5.5 V, Typical at 5 V	220	270	600	ns
t <sub>PHL</sub> , t <sub>PLH</sub>	Propagation delay		V <sub>CC</sub> = 3 to 3.6 V, Typical at 3.3 V		260	500	ns
			V <sub>CC</sub> = 4.5 to 5.5 V, Typical at 5 V		260	450	ns
t <sub>SK(P)</sub>	Pulse skew,  t <sub>PHL</sub> - t <sub>PLH</sub>		V <sub>CC</sub> = 3 to 3.6 V, Typical at 3.3 V		2	15	ns
			V <sub>CC</sub> = 4.5 to 5.5 V, Typical at 5 V		2	15	ns
t <sub>PHZ</sub> , t <sub>PLZ</sub>	Disable time	RE = X		80	200	ns	
t <sub>PZH</sub> , t <sub>PZL</sub>	Enable time	RE = 0 V	See <a href="#">Figure 7-4</a> and <a href="#">Figure 7-5</a>		200	650	ns
		RE = V <sub>IO</sub>		6	11	μs	
<b>Receiver</b>							
t <sub>r</sub> , t <sub>f</sub>	Output rise/fall time	C <sub>L</sub> = 15 pF	See <a href="#">Figure 7-6</a>		5	20	ns
t <sub>PHL</sub> , t <sub>PLH</sub>	Propagation delay				620	1200	ns
t <sub>SK(P)</sub>	Pulse skew,  t <sub>PHL</sub> - t <sub>PLH</sub>				10	40	ns
t <sub>PHZ</sub> , t <sub>PLZ</sub>	Disable time	DE = X	See <a href="#">Figure 7-7</a>		20	60	ns
t <sub>PZH(1)</sub>	Enable time	DE = V <sub>IO</sub>			80	155	ns
t <sub>PZL(1)</sub>	Enable time	DE = V <sub>IO</sub>			650	1250	ns
t <sub>PZH(2)</sub> , t <sub>PZL(2)</sub>	Enable time	V <sub>IO</sub> = 1.65 V to 1.95 V; DE = 0 V	See <a href="#">Figure 7-8</a>		7	12	μs
		V <sub>IO</sub> = 3 V to 3.6 V; DE = 0 V			7	12	

(1) A, B are RX input, Y/Z are driver output terminals in Full duplex mode

## 6.9 Switching Characteristics\_20 Mbps

20-Mbps (SLR = GND) over recommended operating conditions. All typical values are at 25°C and supply voltage of V<sub>CC</sub> = 5 V, V<sub>IO</sub> = 3.3 V. <sup>(1)</sup>

PARAMETER		TEST CONDITIONS		MIN	TYP	MAX	UNIT
<b>Driver</b>							
t <sub>r</sub> , t <sub>f</sub>	Differential output rise/fall time	R <sub>L</sub> = 54 Ω, C <sub>L</sub> = 50 pF See <a href="#">Figure 7-3</a>	V <sub>CC</sub> = 3 to 3.6 V, Typical at 3.3 V	5	9	15	ns
			V <sub>CC</sub> = 4.5 to 5.5 V, Typical at 5 V	4.5	8	15	ns
t <sub>PHL</sub> , t <sub>PLH</sub>	Propagation delay		V <sub>IO</sub> = 1.65 V to 1.95 V	14	25	50	ns
			V <sub>IO</sub> = 3 V to 3.6 V	9	20	40	ns
t <sub>SK(P)</sub>	Pulse skew,  t <sub>PHL</sub> - t <sub>PLH</sub>		V <sub>CC</sub> = 3 to 3.6 V, Typical at 3.3 V		1	3.5	ns
			V <sub>CC</sub> = 4.5 to 5.5 V, Typical at 5 V		1	3.5	ns
t <sub>PHZ</sub> , t <sub>PLZ</sub>	Disable time	RE = X	See <a href="#">Figure 7-4</a> and <a href="#">Figure 7-5</a>		25	50	ns
t <sub>PZH</sub> , t <sub>PZL</sub>	Enable time	RE = 0 V	See <a href="#">Figure 7-4</a> and <a href="#">Figure 7-5</a>		30	70	ns
t <sub>PZH</sub> , t <sub>PZL</sub>	Enable time	RE = V <sub>IO</sub> , V <sub>IO</sub> = 1.65 V to 1.95 V	See <a href="#">Figure 7-4</a> and <a href="#">Figure 7-5</a>		6	11	μs
		RE = V <sub>IO</sub> , V <sub>IO</sub> = 3 V to 3.6 V			6	11	
<b>Receiver</b>							



## 6.9 Switching Characteristics\_20 Mbps (continued)

20-Mbps (SLR = GND) over recommended operating conditions. All typical values are at 25°C and supply voltage of  $V_{CC} = 5$  V,  $V_{IO} = 3.3$  V. <sup>(1)</sup>

PARAMETER		TEST CONDITIONS		MIN	TYP	MAX	UNIT
$t_r, t_f$	Output rise/fall time	$C_L = 15$ pF	See <a href="#">Figure 7-6</a>		5	10	ns
$t_{PHL}, t_{PLH}$	Propagation delay				30	55	ns
$t_{SK(P)}$	Pulse skew, $ t_{PHL} - t_{PLH} $					4	ns
$t_{PHZ}, t_{PLZ}$	Disable time	DE = X	See <a href="#">Figure 7-7</a>		20	58	ns
$t_{PZH(1)}, t_{PZL(1)}$	Enable time	DE = $V_{IO}$			80	155	ns
$t_{PZH(2)}, t_{PZL(2)}$	Enable time	$V_{IO} = 1.65$ V to 1.95 V; DE = 0 V $V_{IO} = 3$ V to 3.6 V; DE = 0 V		See <a href="#">Figure 7-8</a>		6	11
					6	11	$\mu$ s

(1) A, B are RX input, Y/Z are driver output terminals in Full duplex mode.

## 6.10 Switching Characteristics\_Termination resistor

Parameters over recommended operating conditions. All typical values are at 25°C and supply voltage of  $V_{CC} = 5$  V,  $V_{IO} = 3.3$  V, unless otherwise noted.

PARAMETER		TEST CONDITIONS		MIN	TYP	MAX	UNIT
$t_{DTEN}$	Driver terminal Termination resistor turn-on time	H/ $\bar{F}$ = GND, $V_{IO} = 3$ to 3.6 V, DE = GND, $V_{YZ} = 2$ V, $V_Z = 0$ V See <a href="#">Figure 7-9</a>			1500	4000	ns
$t_{DTZ}$	Driver terminal Termination resistor turn-off time	H/ $\bar{F}$ = GND, $V_{IO} = 3$ to 3.6 V, DE = GND, $V_{YZ} = 2$ V, $V_Z = 0$ V See <a href="#">Figure 7-9</a>			4600	7200	ns
$t_{RTEN}$	Receiver terminal Termination resistor turn-on time	H/ $\bar{F}$ = GND, $V_{IO} = 3$ to 3.6 V, $\overline{RE} = X$ , $V_{AB} = 2$ V, $V_B = 0$ V See <a href="#">Figure 7-10</a>			1500	4000	ns
$t_{RTZ}$	Receiver terminal Termination resistor turn-off time	H/ $\bar{F}$ = GND, $V_{IO} = 3$ to 3.6 V, $\overline{RE} = X$ , $V_{AB} = 2$ V, $V_B = 0$ V See <a href="#">Figure 7-10</a>			4600	7200	ns

## 6.11 Switching Characteristics\_Duplex switching

Parameters over recommended operating conditions. All typical values are at 25°C and supply voltage of  $V_{CC} = 5$  V,  $V_{IO} = 3.3$  V, unless otherwise noted.

PARAMETER		TEST CONDITIONS		MIN	TYP	MAX	UNIT
$t_{HFD}$	Time to switch from half to full duplex mode	$V_{IO} = 3$ to 3.6 V, Driver and receiver enabled, TERM_TX = $V_{IO}$ See <a href="#">Figure 7-11</a>			0.1	1.2	$\mu$ s
$t_{FHD}$	Time to switch from full to half duplex mode	$V_{IO} = 3$ to 3.6 V, Driver and receiver enabled, TERM_TX = $V_{IO}$ See <a href="#">Figure 7-11</a>			0.1	1.2	$\mu$ s

### 6.12 Typical Characteristics

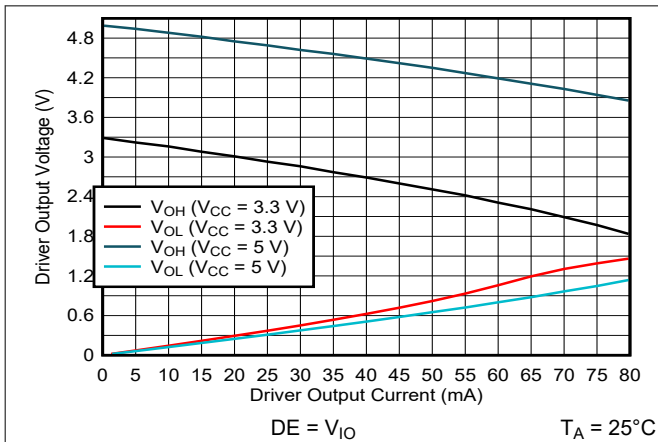


Figure 6-1. Driver Output voltage vs Driver Output Current

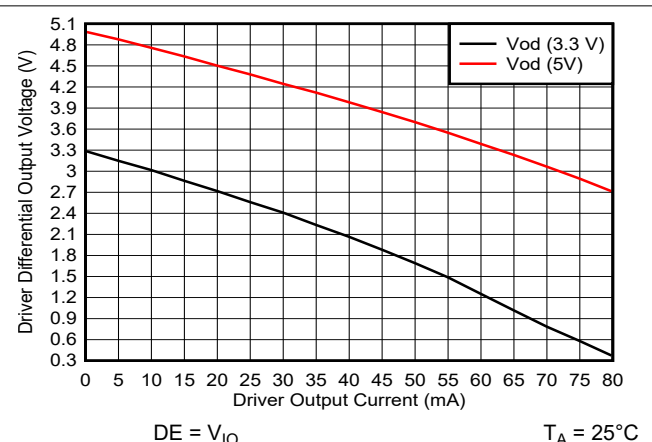


Figure 6-2. Driver Differential Output voltage vs Driver Output Current

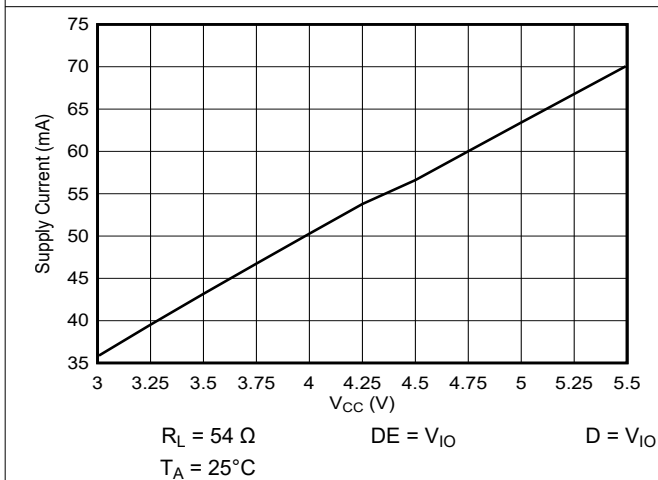


Figure 6-3. Supply Current vs Supply Voltage

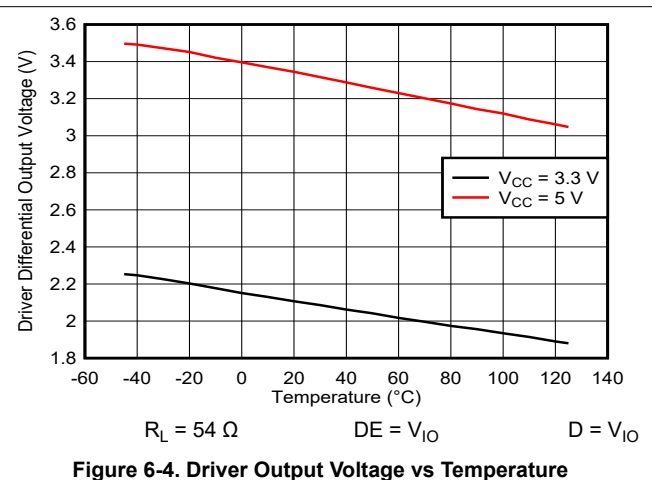


Figure 6-4. Driver Output Voltage vs Temperature

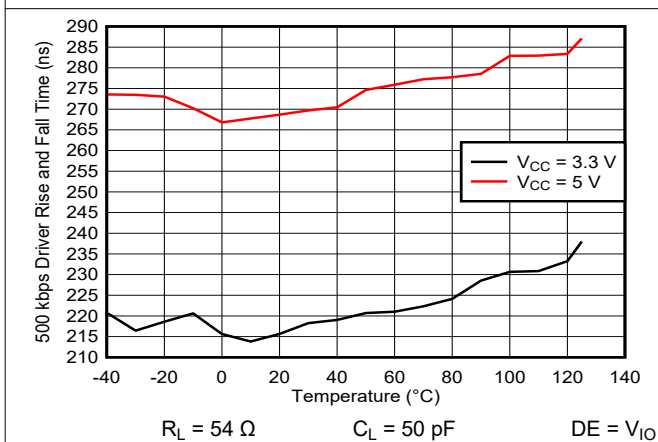


Figure 6-5. Driver Rise or Fall Time vs Temperature (500 kbps)

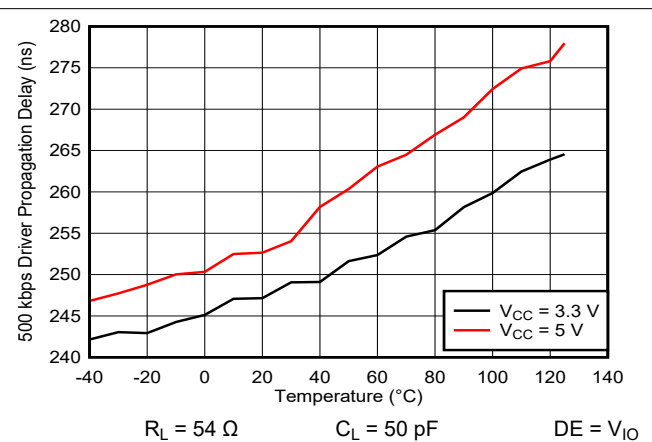


Figure 6-6. Driver Propagation Delay vs Temperature (500 kbps)

### 6.12 Typical Characteristics (continued)

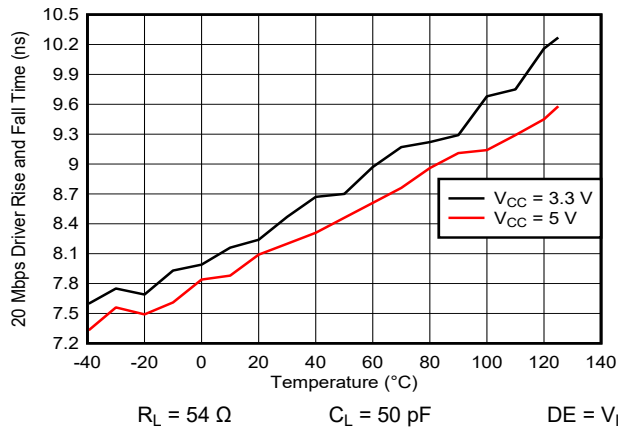


Figure 6-7. Driver Rise or Fall Time vs Temperature (20 Mbps)

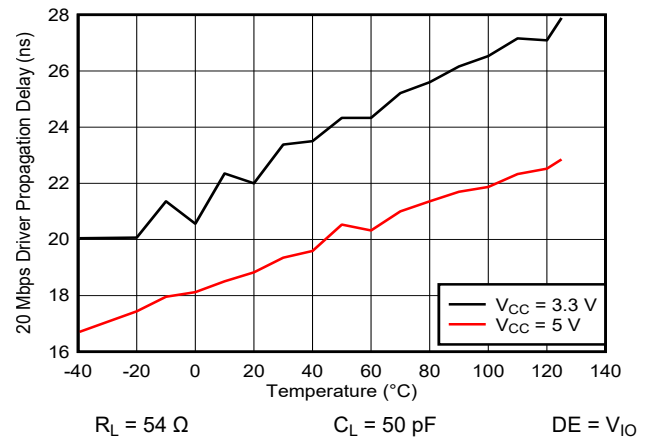


Figure 6-8. Driver Propagation Delay vs Temperature (20 Mbps)

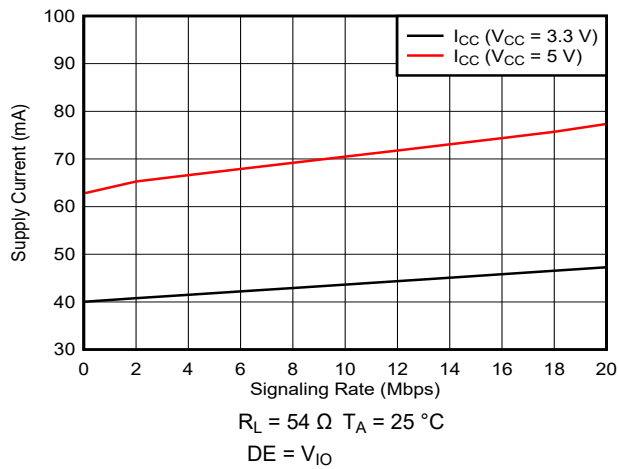
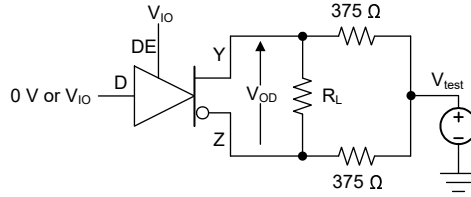
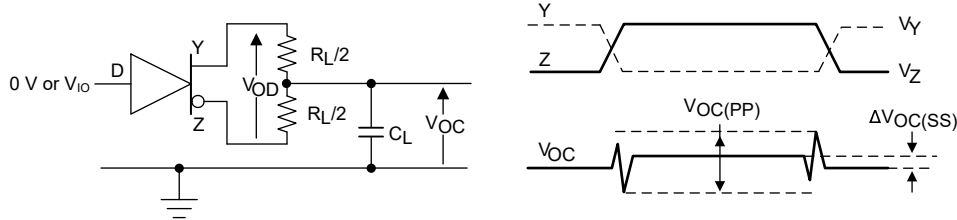


Figure 6-9. Supply Current vs Signal Rate (20 Mbps)

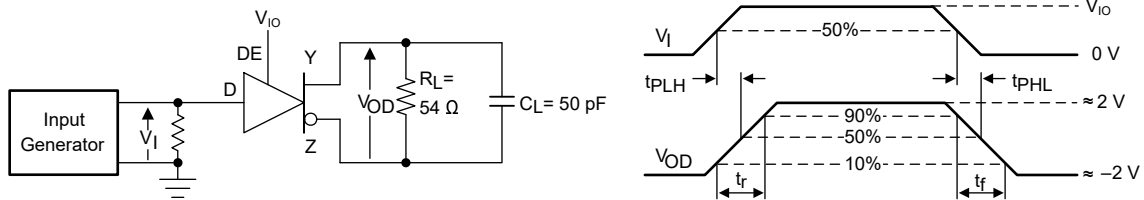
## 7 Parameter Measurement Information



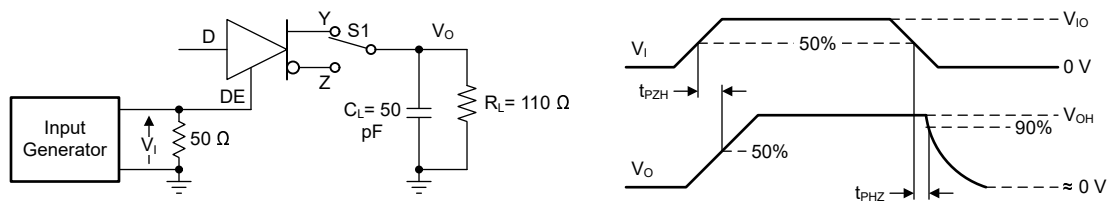
**Figure 7-1. Measurement of Driver Differential Output Voltage With Common-Mode Load**



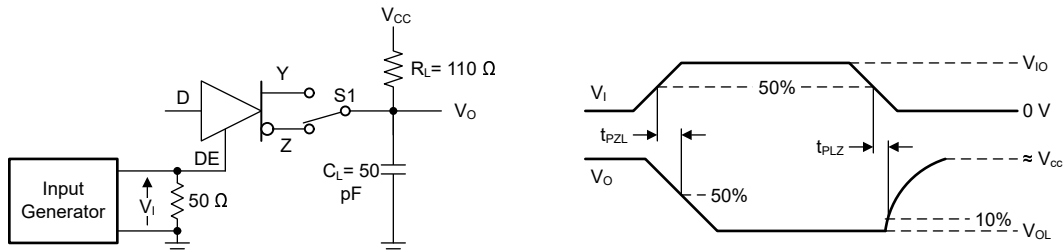
**Figure 7-2. Measurement of Driver Differential and Common-Mode Output With RS-485 Load**



**Figure 7-3. Measurement of Driver Differential Output Rise and Fall Times and Propagation Delays**



**Figure 7-4. Measurement of Driver Enable and Disable Times With Active High Output and Pull-Down Load**



**Figure 7-5. Measurement of Driver Enable and Disable Times With Active Low Output and Pull-up Load**

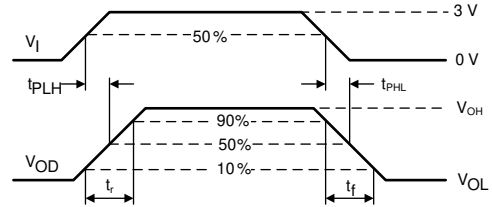
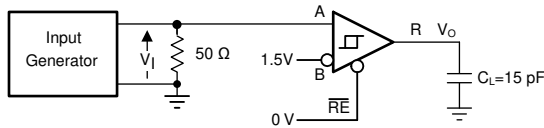


Figure 7-6. Measurement of Receiver Output Rise and Fall Times and Propagation Delays

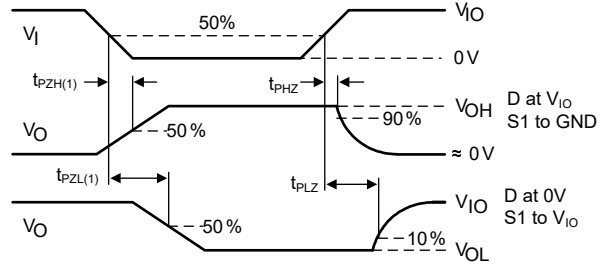
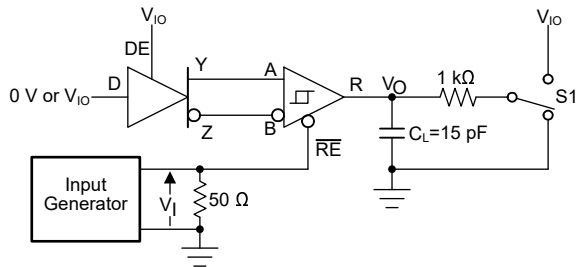


Figure 7-7. Measurement of Receiver Enable/Disable Times With Driver Enabled

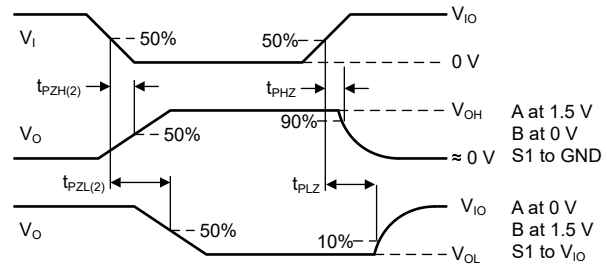
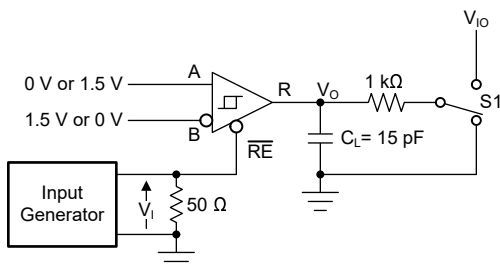


Figure 7-8. Measurement of Receiver Enable Times With Driver Disabled

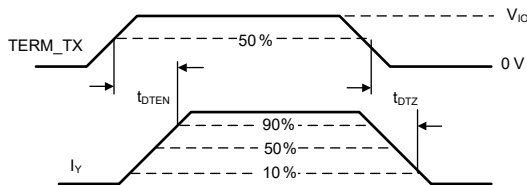
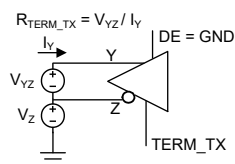


Figure 7-9. Measurement of Enable and Disable times of Driver Terminal Termination Resistor

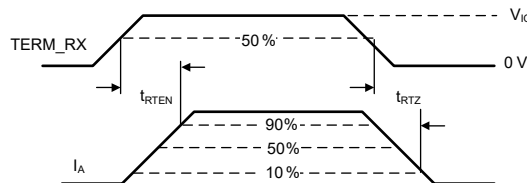
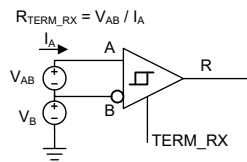
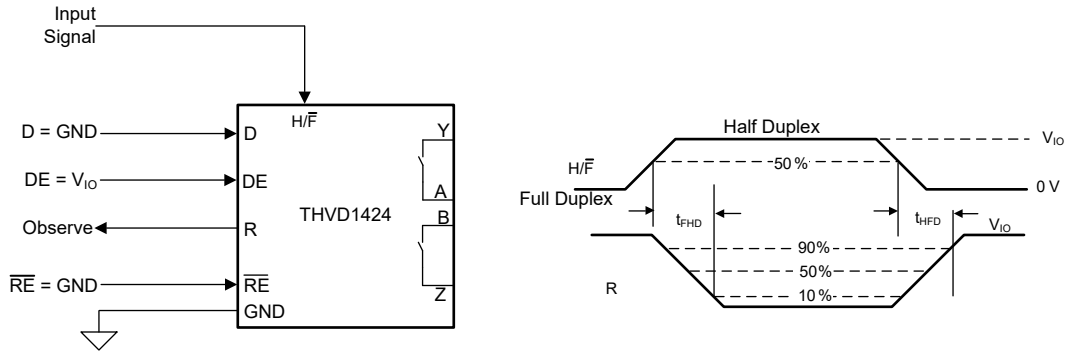


Figure 7-10. Measurement of Enable and Disable times of Receiver Terminal Termination Resistor



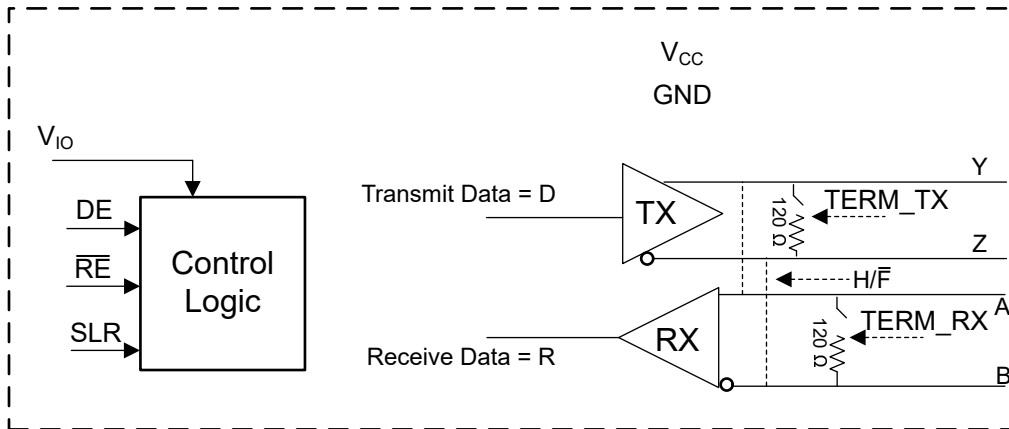
**Figure 7-11. Measurement of Time to Switch from Half duplex mode to Full duplex mode and vice versa**

## 8 Detailed Description

### 8.1 Overview

The THVD1424 is a flexible RS-485 transceiver which can be used in half-duplex or full-duplex RS-485 networks by configuring the pin  $H/\bar{F}$ . The device has slew rate control pin SLR which can be used to set the device in maximum 20 Mbps mode or slew rate limited 500 kbps mode. THVD1424 also has on-chip  $120\ \Omega$  termination resistor across Y/Z terminals and also across A/B terminals. Termination resistors are controlled using two pins TERM\_TX and TERM\_RX.

### 8.2 Functional Block Diagrams



### 8.3 Feature Description

The THVD1424 operates from 3 to 5.5V bus supply. The device has a  $V_{IO}$  pin which allows it to interface to 1.8 V, 2.5 V, 3.3 V or 5 V logic interface. Internal ESD protection circuits protect the transceiver against Electrostatic Discharges (ESD) according to IEC 61000-4-2 of up to  $\pm 8$  kV (Contact Discharge),  $\pm 15$  kV (Air Gap Discharge) and against electrical fast transients (EFT) according to IEC 61000-4-4 of up to  $\pm 4$  kV.

### 8.4 Device Functional Modes

THVD1424 has  $H/\bar{F}$  pin which allows it to be used in half-duplex or full duplex networks. Functional operation of  $H/\bar{F}$  pin is described in table.

**Table 8-1. Duplex switching function table**

Signal state	Driver	Receiver	Comment
$H/\bar{F} = V_{IO}$	Driver output pins are Y and Z	Receiver input pins are Y and Z	Half duplex mode: Driver and receiver share same bus pins, and device state is controlled by DE and $\bar{R}\bar{E}$ pins
$H/\bar{F} = GND$	Driver output pins are Y and Z	Receiver input pins are A and B	Full duplex mode: This is the default state of the device in case $H/\bar{F}$ is floating.

When the driver enable pin, DE, is logic high, the differential outputs Y and Z follow the logic states at data input D. A logic high at D causes Y to turn high and Z to turn low. In this case, the differential output voltage defined as  $V_{OD} = V_Y - V_Z$  is positive. When D is low, the output states reverse, Z turns high, Y becomes low, and  $V_{OD}$  is negative.

When DE is low, both outputs turn high-impedance. In this condition, the logic state at D is irrelevant. The DE pin has an internal pull-down resistor to ground; thus, when left open, the driver is disabled (high-impedance) by default. The D pin has an internal pull-up resistor to  $V_{IO}$ , thus, when left open while the driver is enabled, output Y turns high and Z turns low.

**Table 8-2. Driver Function Table**

INPUT	ENABLE	OUTPUTS		FUNCTION
		Y	Z	
H	H	H	L	Actively drive bus high
L	H	L	H	Actively drive bus low
X	L	Z	Z	Driver disabled
X	OPEN	Z	Z	Driver disabled by default
OPEN	H	H	L	Actively drive bus high by default

When the receiver enable pin,  $\overline{RE}$ , is logic low, the receiver is enabled. When the differential input voltage defined as  $V_{ID} = V_A - V_B$  in case of full duplex mode (or  $V_Y - V_Z$  in case of half duplex mode) is positive and higher than the positive input threshold,  $V_{TH+}$ , the receiver output, R, turns high. When  $V_{ID}$  is negative and lower than the negative input threshold,  $V_{TH-}$ , the receiver output, R, turns low. If  $V_{ID}$  is between  $V_{TH+}$  and  $V_{TH-}$ , the output is indeterminate.

When  $\overline{RE}$  is logic high or left open, the receiver output is high-impedance and the magnitude and polarity of  $V_{ID}$  are irrelevant. Internal biasing of the receiver inputs causes the output R to go failsafe-high when the transceiver is disconnected from the bus (open-circuit), the bus lines are shorted (short-circuit), or the bus is not actively driven (idle bus).

**Table 8-3. Receiver Function Table**

DIFFERENTIAL INPUT	ENABLE	OUTPUT	FUNCTION
$V_{ID} = V_A - V_B$ (full duplex mode) or $V_Y - V_Z$ (half duplex mode)	RE	R	
$V_{TH+} < V_{ID}$	L	H	Receive valid bus high
$V_{TH-} < V_{ID} < V_{TH+}$	L	?	Indeterminate bus state
$V_{ID} < V_{TH-}$	L	L	Receive valid bus low
X	H	Z	Receiver disabled
X	OPEN	Z	Receiver disabled by default
Open-circuit bus	L	H	Fail-safe high output
Short-circuit bus	L	H	Fail-safe high output
Idle (terminated) bus	L	H	Fail-safe high output

#### 8.4.1 On-Chip Switchable Termination

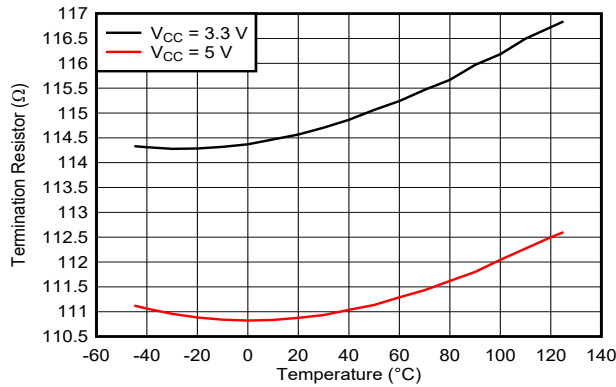
THVD1424 has 2 termination resistors of nominal 120  $\Omega$ , one across Y/Z and another across A/B. Both termination resistors are enabled or disabled using pins as described in [On-chip termination function table](#). Both the termination resistors can be enabled or disabled independent of the state of driver or receiver. Termination is OFF if the device is unpowered or in thermal shutdown.

**Table 8-4. On-chip termination function table**

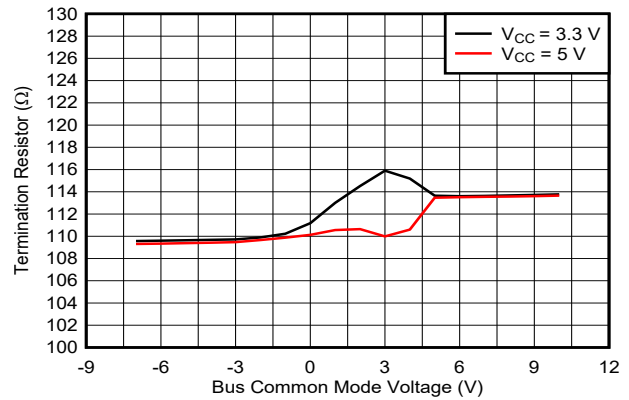
Signal state	Device mode	Function	Comments
TERM_TX = $V_{IO}$	Full duplex mode	120 $\Omega$ enabled between Y and Z	Termination between Y/Z is disabled by default
TERM_TX = GND or floating	Full duplex mode	120 $\Omega$ disabled between Y and Z	
TERM_RX = $V_{IO}$	Full duplex mode	120 $\Omega$ enabled between A and B	Termination between A/B is disabled by default
TERM_RX = GND or floating	Full duplex mode	120 $\Omega$ disabled between A and B	
TERM_RX = X, TERM_TX = $V_{IO}$	Half duplex mode	120 $\Omega$ enabled between Y and Z	In half duplex mode, TERM_RX is don't care and TERM_TX has higher priority
TERM_RX = X, TERM_TX = GND	Half duplex mode	120 $\Omega$ disabled between Y and Z	

On-chip 120  $\Omega$  termination resistor variation with temperature and across common mode voltage is shown in following images.



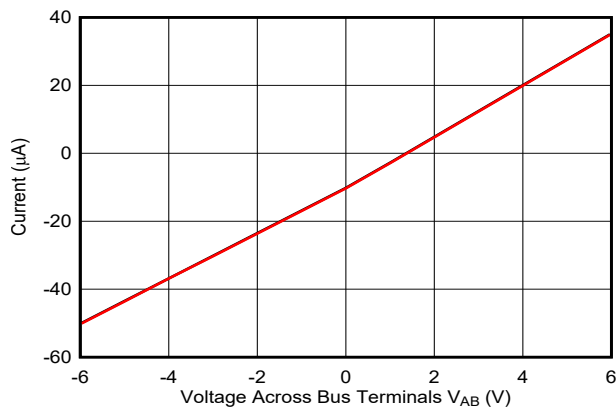


**Figure 8-1. Termination resistor vs Temperature**

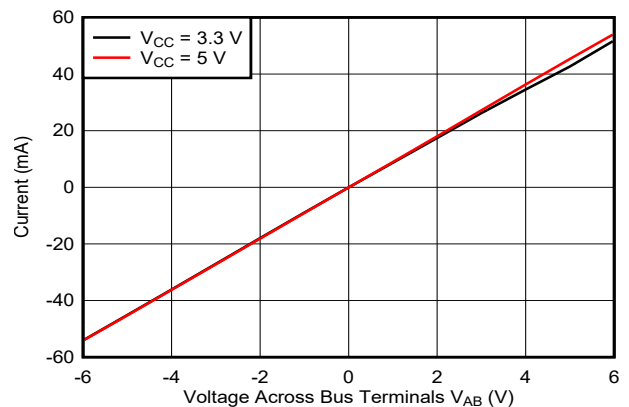


**Figure 8-2. Termination resistor vs Bus common mode voltage**

THVD1424 on-chip termination resistor has been designed so the termination block offers a resistive load to the bus, and does not alter the magnitude or phase of the bus signals from DC to 20 Mbps signaling. See the following images with the bus voltage swept from -6 V to +6 V. Current into the bus changes linearly in both conditions of termination ON or OFF.



**Figure 8-3. Voltage vs Current across AB bus pins with termination OFF**



**Figure 8-4. Voltage vs Current across AB bus pins with termination ON**

### 8.4.2 Operational Data rate

THVD1424 can be used in slow speed or fast speed RS-485 networks by configuring Slew rate control (SLR) pin. Table below describes slew rate control function.

**Table 8-5. Slew rate control function table**

Signal state	Driver	Receiver	Comment
SLR = $V_{IO}$	Maximum speed of operation = 500kbps	Maximum speed of operation = 500kbps	Active high slew rate limiting applied on driver output and glitch filter in receiver path enabled
SLR = GND or floating	Maximum speed of operation = 20Mbps	Maximum speed of operation = 20Mbps	Slew rate limiting on driver output disabled and glitch filter in receiver path disabled

Receiver path in the slow speed mode (500 kbps) provides additional noise filtering. To attenuate high frequency noise pulses from the bus which can be wrongly interpreted as valid data, SLR =  $V_{IO}$  enables a low pass filter to filter out pulses with frequency higher than typical 800 kHz.

### 8.4.3 Protection Features

THVD1424 has in-built protection features such as supply undervoltage, bus short circuit and thermal shutdown.

Supply undervoltage protection is present on both  $V_{CC}$  and  $V_{IO}$  supplies. This maintains the bus output and receiver logic output in known driven state when both the supplies are above their rising undervoltage thresholds. Table below describes the device behavior in various scenarios of supply levels.

**Table 8-6. Supply Function Table**

$V_{CC}$	$V_{IO}$	Driver Output	Receiver Output	Termination across bus pins YZ and AB
$> UV_{VCC}(\text{rising})$	$> UV_{VIO}(\text{rising})$	Determined by DE and D inputs	Determined by $\overline{RE}$ and A-B	Determined by TERM_TX and TERM_RX pins
$< UV_{VCC}(\text{falling})$	$> UV_{VIO}(\text{rising})$	High impedance	Undetermined	OFF
$> UV_{VCC}(\text{rising})$	$< UV_{VIO}(\text{falling})$	High impedance	High impedance	Undetermined
$< UV_{VCC}(\text{falling})$	$< UV_{VIO}(\text{falling})$	High impedance	High impedance	OFF

Bus terminals are protected against high voltage short circuit events up to  $\pm 16$  V. Additionally, bus short circuit current is limited to 250 mA. So in events like bus contention when multiple drivers are driving the bus simultaneously, the current through the bus terminals is internally limited. If the power dissipation makes the junction temperature cross 150 °C, thermal shutdown is activated which disables the driver and receiver and reduces the on-chip power dissipation. The device is enabled once the junction temperature falls by the thermal shutdown hysteresis as specified in electrical parameter section of the data sheet.

## 9 Application Information Disclaimer

### Note

Information in the following applications sections is not part of the TI component specification, and TI does not warrant its accuracy or completeness. TI's customers are responsible for determining suitability of components for their purposes, as well as validating and testing their design implementation to confirm system functionality.

### 9.1 Application Information

The THVD1424 is a flexible RS-485 transceiver used for asynchronous data transmissions. The driver and receiver enable pins, slew rate control, duplex control and termination control pins allow the device to be applicable for various point-to-point, multipoint or multidrop network configurations.

### 9.2 Typical Application

An RS-485 bus consists of multiple transceivers connecting in parallel to a bus cable. To eliminate line reflections, each cable end is terminated with a termination resistor,  $R_T$ , whose value matches the characteristic impedance,  $Z_0$ , of the cable. This method, known as parallel termination, allows for higher data rates over longer cable length. THVD1424 has on-chip  $120\ \Omega$  termination resistor well suited for most commonly used cables for RS-485 applications. Figure 9-1 shows two end nodes terminated, while remaining nodes unterminated. THVD1424 can be designed in all node designs. TERM\_TX pin allows configuring the nodes for end nodes and middle nodes in the network.

Figure 9-2 shows termination on end nodes of each pair of cable in a full duplex network. Once again, THVD1424 makes it possible to have common board design for all nodes. TERM\_TX and TERM\_RX pins allow configuration for end nodes and middle nodes.

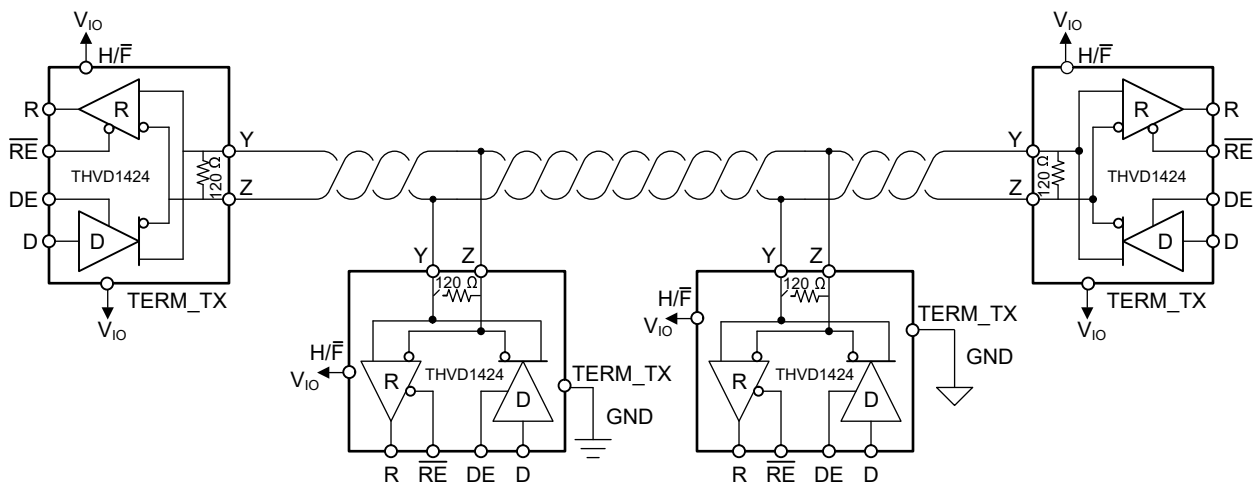
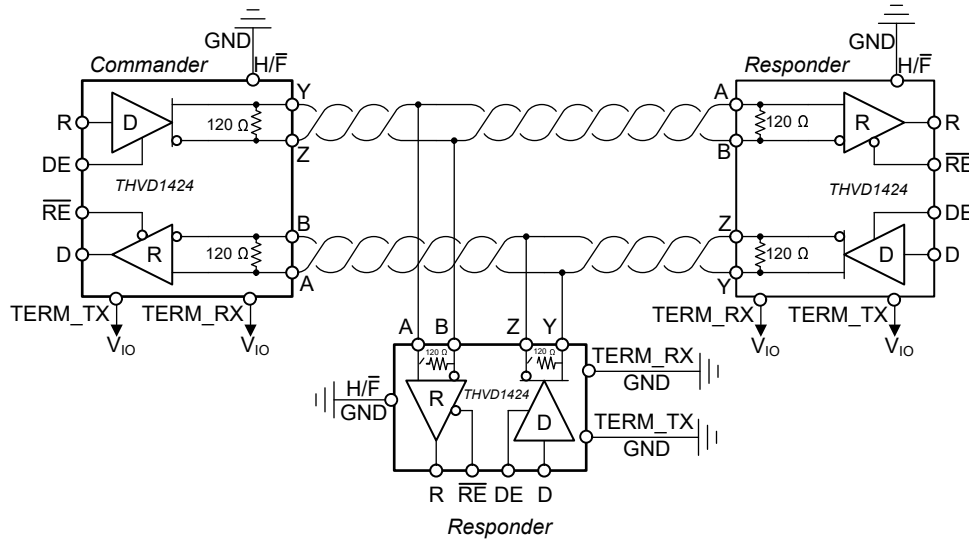


Figure 9-1. Typical RS-485 Network With THVD1424 configured in Half-Duplex mode



**Figure 9-2. Typical RS-485 Network With THVD1424 configured in Full-Duplex mode**

### 9.2.1 Design Requirements

RS-485 is a robust electrical standard suitable for long-distance networking that may be used in a wide range of applications with varying requirements, such as distance, data rate, and number of nodes.

#### 9.2.1.1 Data Rate and Bus Length

There is an inverse relationship between data rate and cable length, which means the higher the data rate, the shorter the cable length; and conversely, the lower the data rate, the longer the cable length. While most RS-485 systems use data rates between 10 kbps and 100 kbps, some applications require data rates up to 300 kbps at distances of 4000 feet and longer. Longer distances are possible by allowing for small signal jitter of up to 5 or 10%.

### 9.2.1.2 Stub Length

When connecting a node to the bus, the distance between the transceiver inputs and the cable trunk, known as the stub, should be as short as possible. Stubs present a non-terminated piece of bus line which can introduce reflections as the length of the stub increases. As a general guideline, the electrical length, or round-trip delay, of a stub should be less than one-tenth of the rise time of the driver, thus giving a maximum physical stub length as shown in [Equation 1](#).

$$L_{(\text{STUB})} \leq 0.1 \times t_r \times v \times c \quad (1)$$

where

- $t_r$  is the 10/90 rise time of the driver
- $c$  is the speed of light ( $3 \times 10^8$  m/s)
- $v$  is the signal velocity of the cable or trace as a factor of  $c$

THVD1424 can be used in both slow-speed and high-speed networks with SLR pin configurability. Slew rate limiting makes the driver output rise/fall time slower so that stub lengths can be increased.

### 9.2.1.3 Bus Loading

The RS-485 standard specifies that a compliant driver must be able to drive 32 unit loads (UL), where 1 unit load represents a load impedance of approximately 12 kΩ. Because the THVD1424 consists of 1/8 UL transceivers, connecting up to 256 transceivers to the bus is possible.

### 9.2.1.4 Receiver Failsafe

The differential receiver of the THVD1424 is *failsafe* to invalid bus states caused by the following:

- Open bus conditions, such as a disconnected connector
- Shorted bus conditions, such as cable damage shorting the twisted-pair together
- Idle bus conditions that occur when no driver on the bus is actively driving

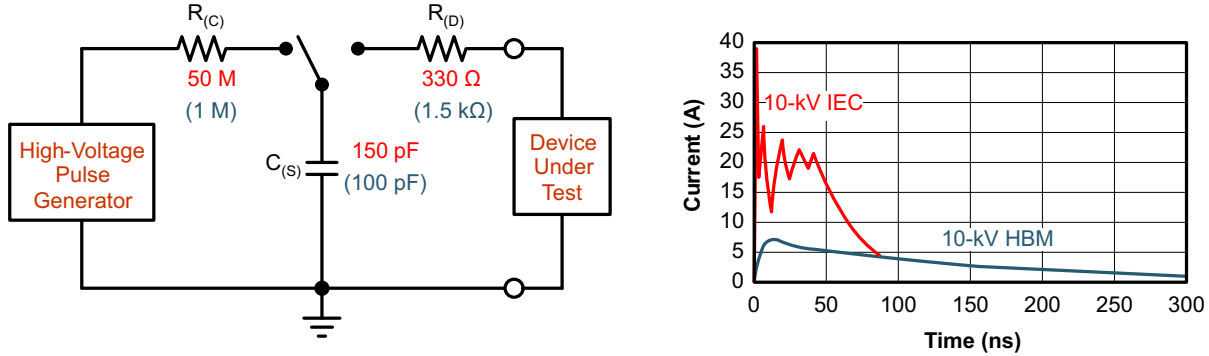
In any of these cases, the differential receiver outputs a failsafe logic high state so that the output of the receiver is not indeterminate.

Receiver failsafe is accomplished by offsetting the receiver thresholds such that the *input indeterminate* range does not include zero volts differential. To comply with the RS-422 and RS-485 standards, the receiver output must output a high when the differential input  $V_{ID}$  is more positive than 200 mV, and must output a low when  $V_{ID}$  is more negative than  $-200$  mV. The receiver parameters which determine the failsafe performance are  $V_{TH+}$ ,  $V_{TH-}$ , and  $V_{HYS}$  (the separation between  $V_{TH+}$  and  $V_{TH-}$ ). As shown in the [Table 8-3](#), differential signals more negative than  $-200$  mV always causes a low receiver output, and differential signals more positive than 200 mV always causes a high receiver output.

When the differential input signal is close to zero, it is still above the  $V_{TH+}$  threshold, and the receiver output is high. Only when the differential input is more than  $V_{HYS}$  below  $V_{TH+}$  does the receiver output transition to a low state. Therefore, the noise immunity of the receiver inputs during a bus fault conditions includes the receiver hysteresis value,  $V_{HYS}$ , as well as the value of  $V_{TH+}$ .

### 9.2.1.5 Transient Protection

The bus pins of the THVD1424 transceiver family include on-chip ESD protection against ±16-kV HBM and ±8-kV IEC 61000-4-2 contact discharge. The International Electrotechnical Commission (IEC) ESD test is far more severe than the HBM ESD test. The 50% higher charge capacitance,  $C_{(S)}$ , and 78% lower discharge resistance,  $R_{(D)}$ , of the IEC model produce significantly higher discharge currents than the HBM model.



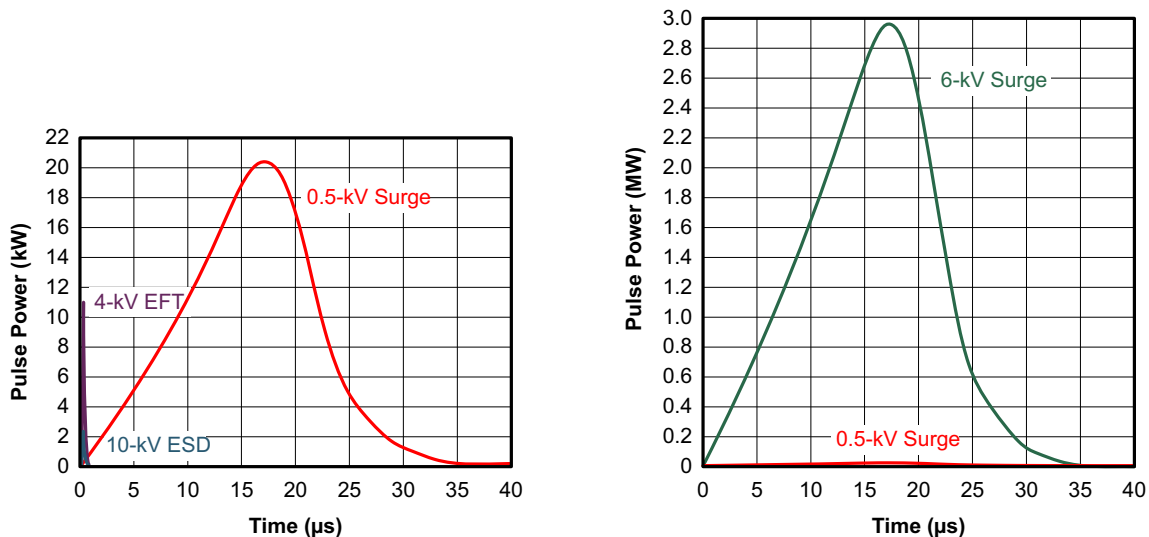
**Figure 9-3. HBM and IEC ESD Models and Currents in Comparison (HBM Values in Parenthesis)**

The on-chip implementation of IEC ESD protection significantly increases the robustness of equipment. Common discharge events occur because of human contact with connectors and cables. Designers may choose to implement protection against longer duration transients, typically referred to as surge transients.

EFTs are generally caused by relay-contact bounce or the interruption of inductive loads. Surge transients often result from lightning strikes (direct strike or an indirect strike which induce voltages and currents), or the switching of power systems, including load changes and short circuit switching. These transients are often encountered in industrial environments, such as factory automation and power-grid systems.

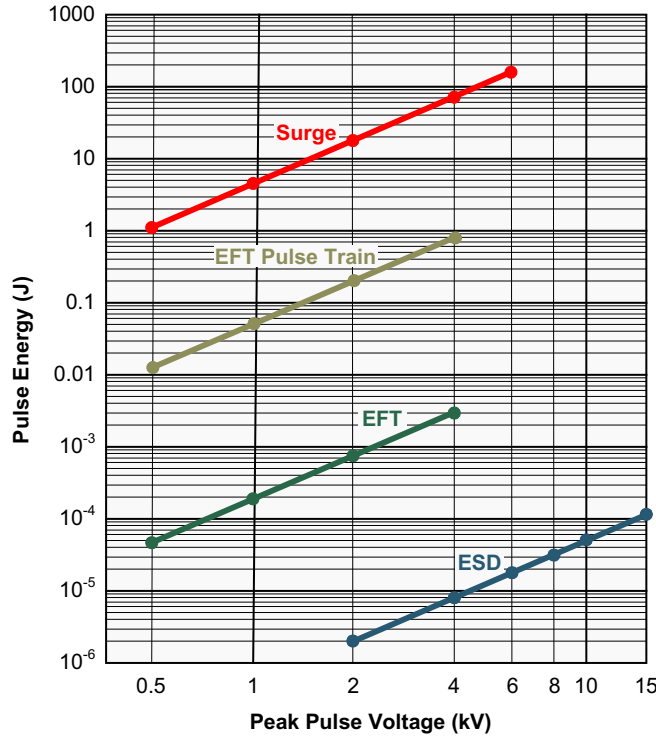
Figure 9-4 compares the pulse-power of the EFT and surge transients with the power caused by an IEC ESD transient. The left hand diagram shows the relative pulse-power for a 0.5-kV surge transient and 4-kV EFT transient, both of which dwarf the 10-kV ESD transient visible in the lower-left corner. 500-V surge transients are representative of events that may occur in factory environments in industrial and process automation.

The right side diagram shows the pulse-power of a 6-kV surge transient, relative to the same 0.5-kV surge transient. 6-kV surge transients are most likely to occur in power generation and power-grid systems.



**Figure 9-4. Power Comparison of ESD, EFT, and Surge Transients**

In the event of surge transients, high-energy content is characterized by long pulse duration and slow decaying pulse power. The electrical energy of a transient that is dumped into the internal protection cells of a transceiver is converted into thermal energy, which heats and destroys the protection cells, thus destroying the transceiver. Figure 9-5 shows the large differences in transient energies for single ESD, EFT, surge transients, and an EFT pulse train that is commonly applied during compliance testing.



**Figure 9-5. Comparison of Transient Energies**

### 9.2.2 Detailed Design Procedure

To protect bus nodes against high-energy transients such as surge, the implementation of external transient protection devices is necessary. Figure 9-6 and Figure 9-7 suggest a protection circuit against 1 kV surge (IEC 61000-4-5) transients. Table 9-1 shows the associated bill of materials.

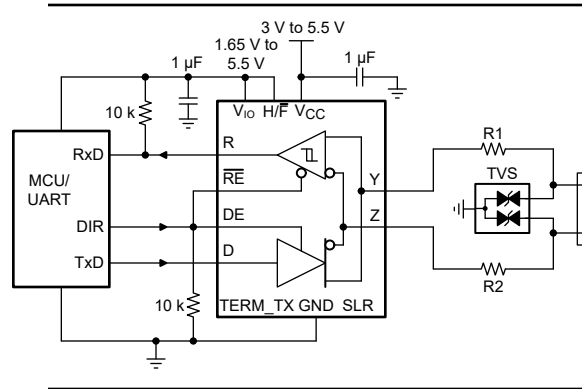


Figure 9-6. Transient Protection Against Surge Transients for THVD1424 Configured in Half-Duplex Mode

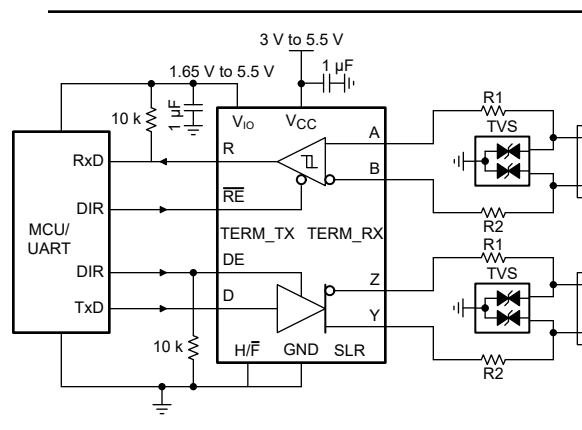


Figure 9-7. Transient Protection Against Surge Transients for THVD1424 Configured in Full-Duplex Mode

Table 9-1. Bill of Materials

DEVICE	FUNCTION	ORDER NUMBER	MANUFACTURER <sup>(1)</sup>
XCVR	RS-485 transceiver	THVD1424	TI
R1	10-Ω, pulse-proof thick-film resistor	CRCW0603010RJNEAHP	Vishay
R2			
TVS	Bidirectional 400-W transient suppressor	CDSOT23-SM712	Bourns

(1) See the [Third Part Disclaimer](#).



### 9.2.3 Application Curves

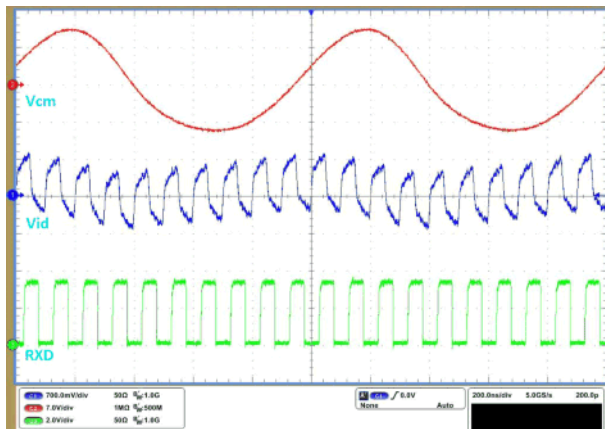


Figure 9-8. THVD1424 Receiver Waveforms at 20 Mbps, with Common Mode Moving at 1 Mhz

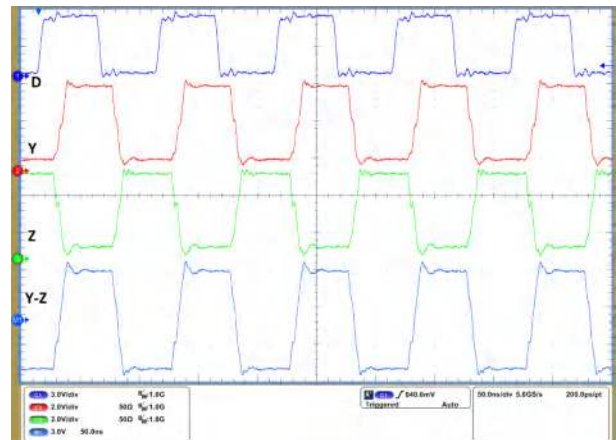


Figure 9-9. THVD1424 Driver Waveforms at 20 Mbps with Termination Enabled

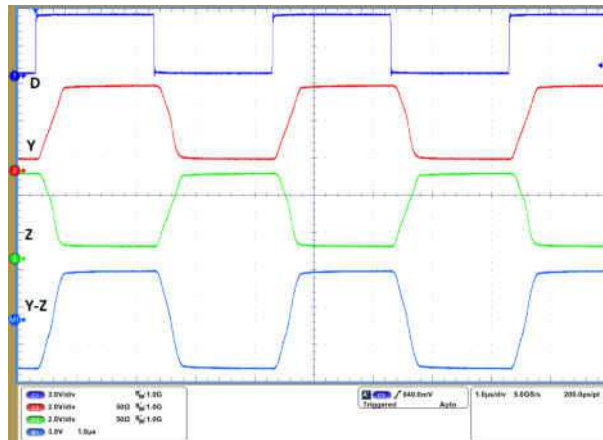


Figure 9-10. THVD1424 Driver Waveforms at 500 kbps with Termination Enabled

## 9.3 Power Supply Recommendations

To ensure reliable operation at all data rates and supply voltages, both supply pins,  $V_{CC}$  and  $V_{IO}$ , should be decoupled with at least 1  $\mu\text{F}$  ceramic capacitor located as close to the supply pins as possible. This helps to reduce supply voltage ripple present on the outputs of switched-mode power supplies and also helps to compensate for the resistance and inductance of the PCB power planes. Proper device operation requires bus side supply  $V_{CC}$  to be greater than or equal to logic supply  $V_{IO}$  during supply ramp up or during steady state operation.

## 9.4 Layout

### 9.4.1 Layout Guidelines

Robust and reliable bus node design often requires the use of external transient protection devices in order to protect against surge transients that may occur in industrial environments. Since these transients have a wide frequency bandwidth (from approximately 3 MHz to 300 MHz), high-frequency layout techniques should be applied during PCB design.

1. Place the protection circuitry close to the bus connector to prevent noise transients from propagating across the board.
2. Use  $V_{CC}$  and ground planes to provide low inductance. Note that high-frequency currents tend to follow the path of least impedance and not the path of least resistance.
3. Design the protection components into the direction of the signal path. Do not force the transient currents to divert from the signal path to reach the protection device.
4. Apply at least 1  $\mu\text{F}$  decoupling capacitors as close as possible to the  $V_{CC}$  and  $V_{IO}$  pins of transceiver, UART and/or controller ICs on the board.
5. Use at least two vias for  $V_{CC}$ ,  $V_{IO}$  and ground connections of decoupling capacitors and protection devices to minimize effective via inductance.
6. Use 1-k $\Omega$  to 10-k $\Omega$  pull-up and pull-down resistors for logic lines to limit noise currents in these lines during transient events.
7. Insert pulse-proof resistors into the Y, Z, A and B bus lines if the TVS clamping voltage is higher than the specified maximum voltage of the transceiver bus pins. These resistors limit the residual clamping current into the transceiver and prevent it from latching up.
8. While pure TVS protection is sufficient for surge transients up to 1 kV, higher transients require metal-oxide varistors (MOVs) which reduce the transients to a few hundred volts of clamping voltage, and transient blocking units (TBUs) that limit transient current to less than 1 mA.

### 9.4.2 Layout Example

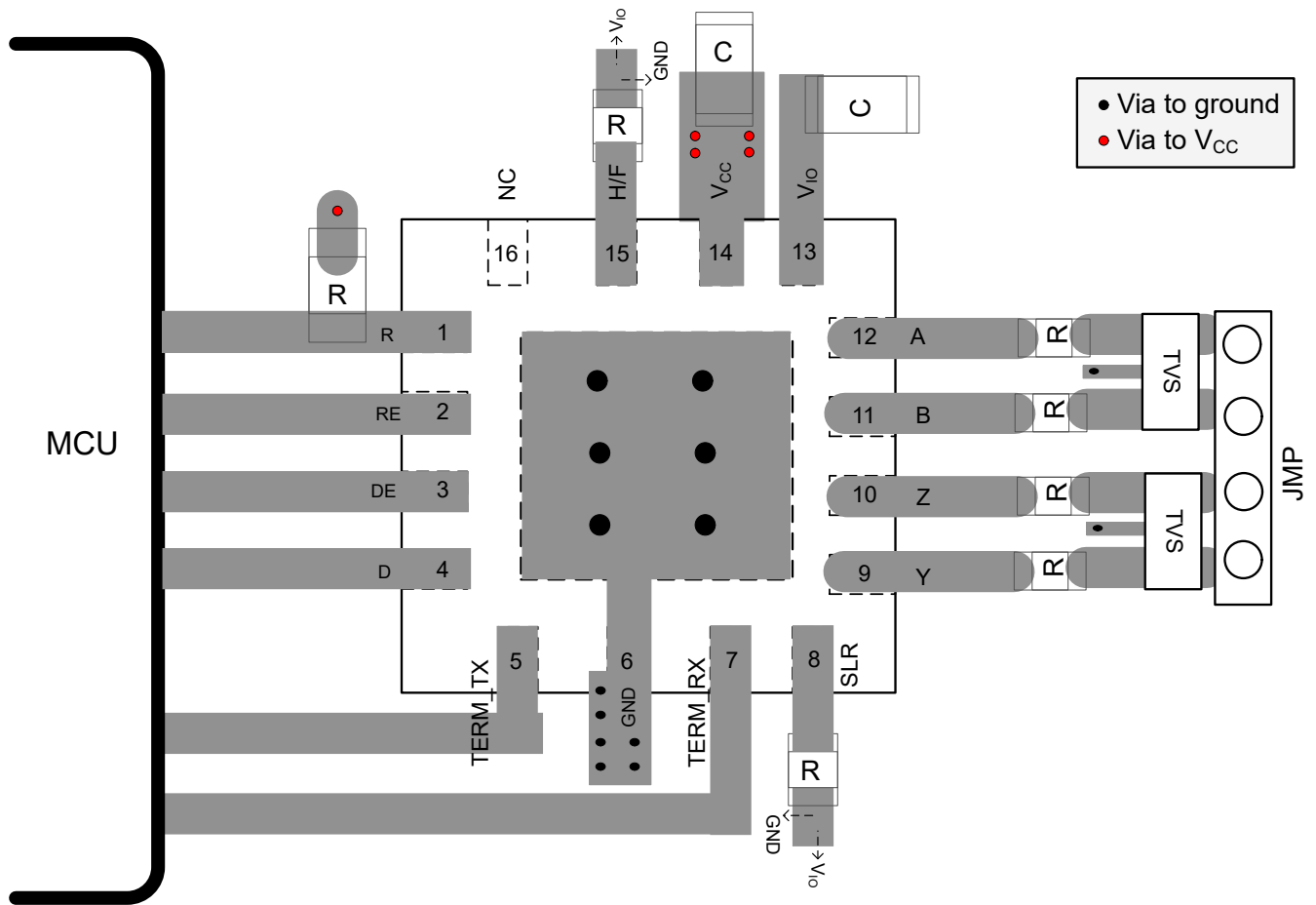


Figure 9-11. Layout Example for THVD1424 in VQFN-16 package

## 10 Device and Documentation Support

### 10.1 Device Support

#### 10.1.1 Third-Party Products Disclaimer

TI'S PUBLICATION OF INFORMATION REGARDING THIRD-PARTY PRODUCTS OR SERVICES DOES NOT CONSTITUTE AN ENDORSEMENT REGARDING THE SUITABILITY OF SUCH PRODUCTS OR SERVICES OR A WARRANTY, REPRESENTATION OR ENDORSEMENT OF SUCH PRODUCTS OR SERVICES, EITHER ALONE OR IN COMBINATION WITH ANY TI PRODUCT OR SERVICE.

### 10.2 Receiving Notification of Documentation Updates

To receive notification of documentation updates, navigate to the device product folder on [ti.com](https://www.ti.com). Click on *Subscribe to updates* to register and receive a weekly digest of any product information that has changed. For change details, review the revision history included in any revised document.

### 10.3 Support Resources

[TI E2E™ support forums](#) are an engineer's go-to source for fast, verified answers and design help — straight from the experts. Search existing answers or ask your own question to get the quick design help you need.

Linked content is provided "AS IS" by the respective contributors. They do not constitute TI specifications and do not necessarily reflect TI's views; see TI's [Terms of Use](#).

### 10.4 Trademarks

TI E2E™ is a trademark of Texas Instruments.

All trademarks are the property of their respective owners.

### 10.5 Electrostatic Discharge Caution



This integrated circuit can be damaged by ESD. Texas Instruments recommends that all integrated circuits be handled with appropriate precautions. Failure to observe proper handling and installation procedures can cause damage.

ESD damage can range from subtle performance degradation to complete device failure. Precision integrated circuits may be more susceptible to damage because very small parametric changes could cause the device not to meet its published specifications.

### 10.6 Glossary

[TI Glossary](#) This glossary lists and explains terms, acronyms, and definitions.

## 11 Mechanical, Packaging, and Orderable Information

The following pages include mechanical, packaging, and orderable information. This information is the most current data available for the designated devices. This data is subject to change without notice and revision of this document. For browser-based versions of this data sheet, refer to the left-hand navigation.

**PACKAGING INFORMATION**

Orderable Device	Status (1)	Package Type	Package Drawing	Pins	Package Qty	Eco Plan (2)	Lead finish/ Ball material (6)	MSL Peak Temp (3)	Op Temp (°C)	Device Marking (4/5)	Samples
THVD1424RGTR	ACTIVE	VQFN	RGT	16	5000	RoHS & Green	NIPDAU	Level-1-260C-UNLIM	-40 to 125	1424	Samples

(1) The marketing status values are defined as follows:

**ACTIVE:** Product device recommended for new designs.

**LIFEBUY:** TI has announced that the device will be discontinued, and a lifetime-buy period is in effect.

**NRND:** Not recommended for new designs. Device is in production to support existing customers, but TI does not recommend using this part in a new design.

**PREVIEW:** Device has been announced but is not in production. Samples may or may not be available.

**OBSELETE:** TI has discontinued the production of the device.

(2) **RoHS:** TI defines "RoHS" to mean semiconductor products that are compliant with the current EU RoHS requirements for all 10 RoHS substances, including the requirement that RoHS substance do not exceed 0.1% by weight in homogeneous materials. Where designed to be soldered at high temperatures, "RoHS" products are suitable for use in specified lead-free processes. TI may reference these types of products as "Pb-Free".

**RoHS Exempt:** TI defines "RoHS Exempt" to mean products that contain lead but are compliant with EU RoHS pursuant to a specific EU RoHS exemption.

**Green:** TI defines "Green" to mean the content of Chlorine (Cl) and Bromine (Br) based flame retardants meet JS709B low halogen requirements of <=1000ppm threshold. Antimony trioxide based flame retardants must also meet the <=1000ppm threshold requirement.

(3) MSL, Peak Temp. - The Moisture Sensitivity Level rating according to the JEDEC industry standard classifications, and peak solder temperature.

(4) There may be additional marking, which relates to the logo, the lot trace code information, or the environmental category on the device.

(5) Multiple Device Markings will be inside parentheses. Only one Device Marking contained in parentheses and separated by a "~" will appear on a device. If a line is indented then it is a continuation of the previous line and the two combined represent the entire Device Marking for that device.

(6) Lead finish/Ball material - Orderable Devices may have multiple material finish options. Finish options are separated by a vertical ruled line. Lead finish/Ball material values may wrap to two lines if the finish value exceeds the maximum column width.

**Important Information and Disclaimer:**The information provided on this page represents TI's knowledge and belief as of the date that it is provided. TI bases its knowledge and belief on information provided by third parties, and makes no representation or warranty as to the accuracy of such information. Efforts are underway to better integrate information from third parties. TI has taken and continues to take reasonable steps to provide representative and accurate information but may not have conducted destructive testing or chemical analysis on incoming materials and chemicals. TI and TI suppliers consider certain information to be proprietary, and thus CAS numbers and other limited information may not be available for release.

In no event shall TI's liability arising out of such information exceed the total purchase price of the TI part(s) at issue in this document sold by TI to Customer on an annual basis.

**TAPE AND REEL INFORMATION**

**QUADRANT ASSIGNMENTS FOR PIN 1 ORIENTATION IN TAPE**


\*All dimensions are nominal

Device	Package Type	Package Drawing	Pins	SPQ	Reel Diameter (mm)	Reel Width W1 (mm)	A0 (mm)	B0 (mm)	K0 (mm)	P1 (mm)	W (mm)	Pin1 Quadrant
THVD1424RGTR	VQFN	RGT	16	5000	330.0	12.4	3.3	3.3	1.1	8.0	12.0	Q2

**TAPE AND REEL BOX DIMENSIONS**


\*All dimensions are nominal

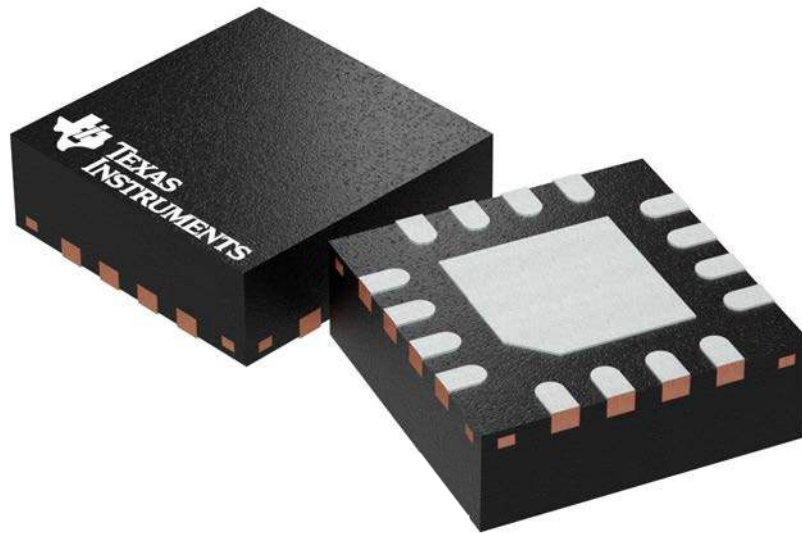
Device	Package Type	Package Drawing	Pins	SPQ	Length (mm)	Width (mm)	Height (mm)
THVD1424RGTR	VQFN	RGT	16	5000	367.0	367.0	35.0

**RGT 16**

**GENERIC PACKAGE VIEW**

**VQFN - 1 mm max height**

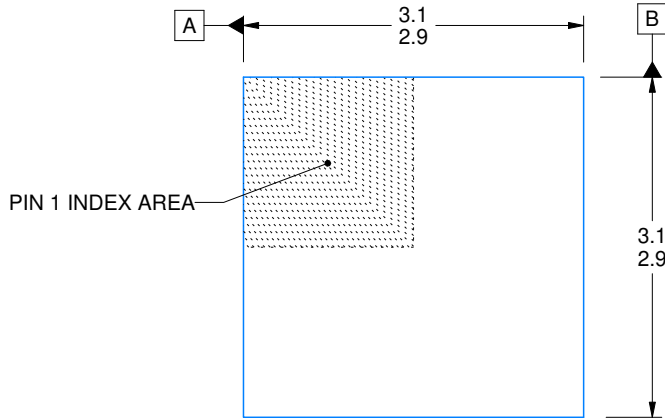
PLASTIC QUAD FLATPACK - NO LEAD



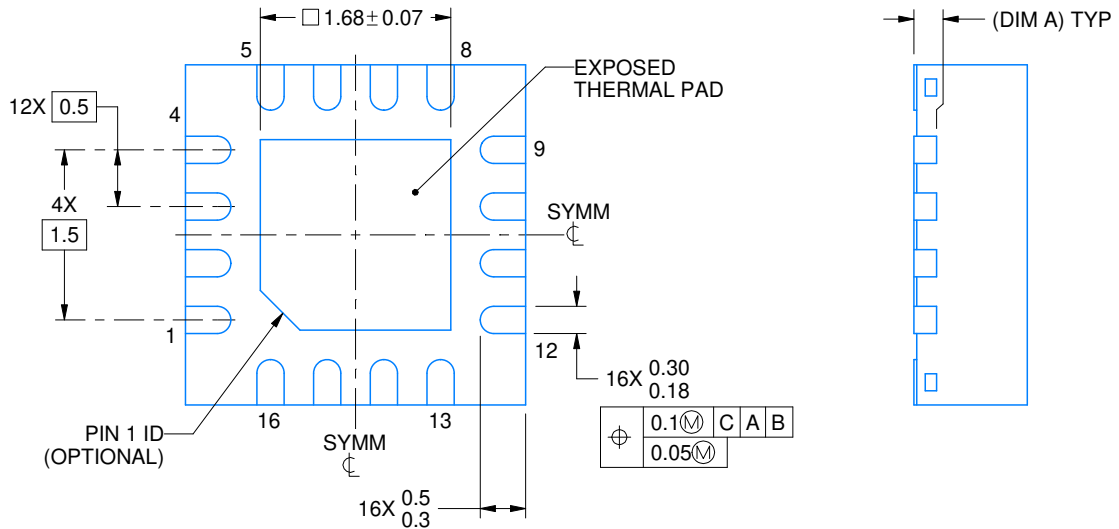
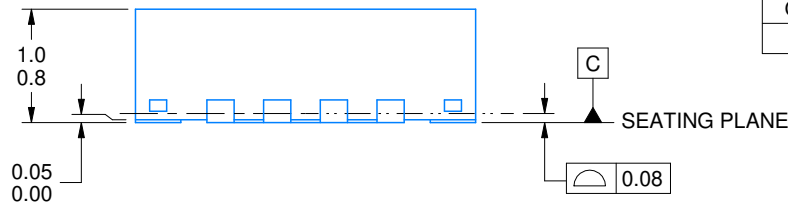
Images above are just a representation of the package family, actual package may vary.  
Refer to the product data sheet for package details.

4203495/1





SIDE WALL METAL THICKNESS DIM A	
OPTION 1	OPTION 2
0.1	0.2



4222419/D 04/2022

NOTES:

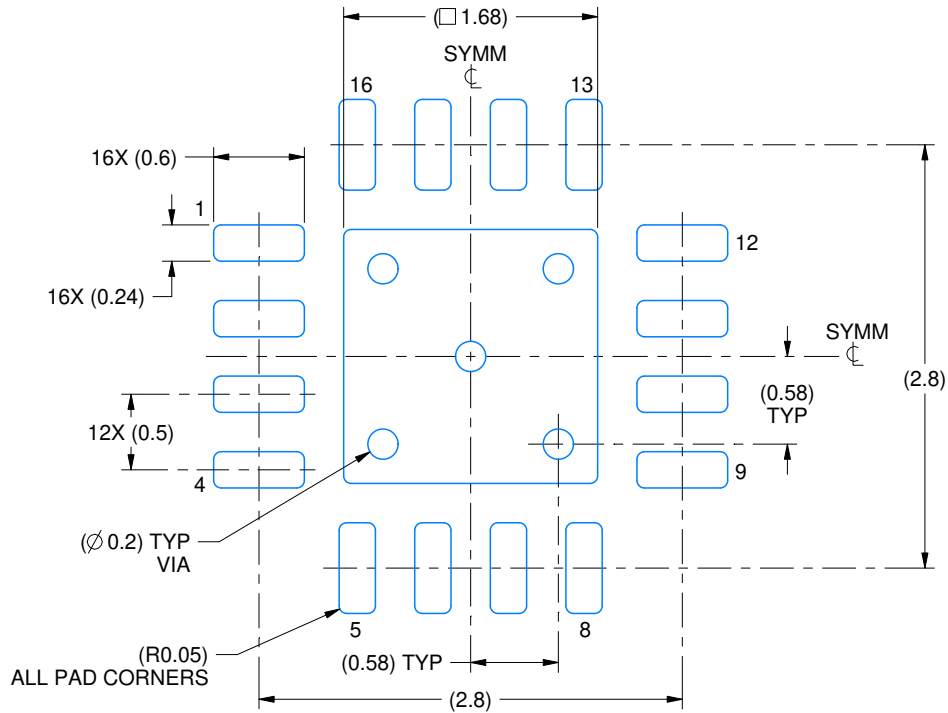
1. All linear dimensions are in millimeters. Any dimensions in parenthesis are for reference only. Dimensioning and tolerancing per ASME Y14.5M.
2. This drawing is subject to change without notice.
3. The package thermal pad must be soldered to the printed circuit board for thermal and mechanical performance.

# EXAMPLE BOARD LAYOUT

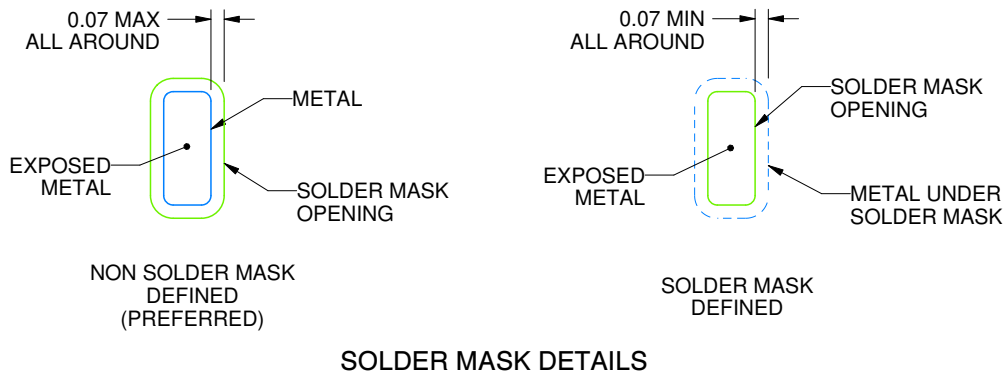
RGT0016C

VQFN - 1 mm max height

PLASTIC QUAD FLATPACK - NO LEAD



LAND PATTERN EXAMPLE  
EXPOSED METAL SHOWN  
SCALE:20X



SOLDER MASK DETAILS

4222419/D 04/2022

NOTES: (continued)

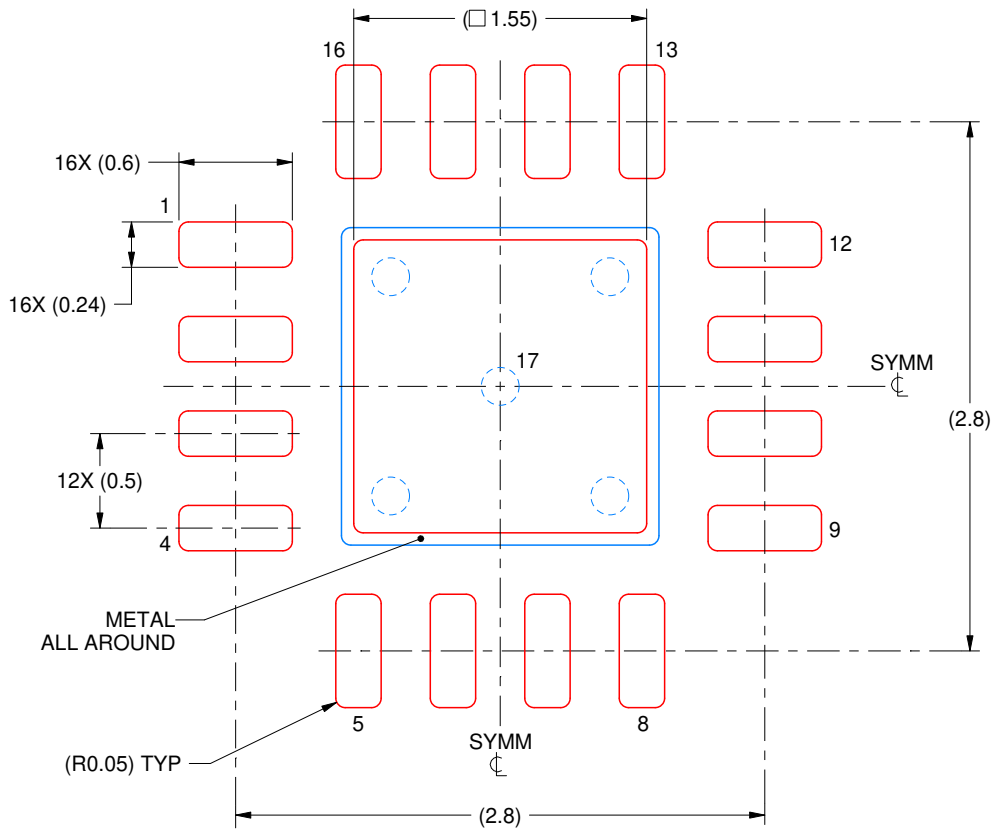
4. This package is designed to be soldered to a thermal pad on the board. For more information, see Texas Instruments literature number SLUA271 ([www.ti.com/lit/slua271](http://www.ti.com/lit/slua271)).
5. Vias are optional depending on application, refer to device data sheet. If any vias are implemented, refer to their locations shown on this view. It is recommended that vias under paste be filled, plugged or tented.

# EXAMPLE STENCIL DESIGN

RGT0016C

VQFN - 1 mm max height

PLASTIC QUAD FLATPACK - NO LEAD



**SOLDER PASTE EXAMPLE**  
BASED ON 0.125 mm THICK STENCIL

EXPOSED PAD 17:  
85% PRINTED SOLDER COVERAGE BY AREA UNDER PACKAGE  
SCALE:25X

4222419/D 04/2022

NOTES: (continued)

6. Laser cutting apertures with trapezoidal walls and rounded corners may offer better paste release. IPC-7525 may have alternate design recommendations.

## IMPORTANT NOTICE AND DISCLAIMER

TI PROVIDES TECHNICAL AND RELIABILITY DATA (INCLUDING DATA SHEETS), DESIGN RESOURCES (INCLUDING REFERENCE DESIGNS), APPLICATION OR OTHER DESIGN ADVICE, WEB TOOLS, SAFETY INFORMATION, AND OTHER RESOURCES "AS IS" AND WITH ALL FAULTS, AND DISCLAIMS ALL WARRANTIES, EXPRESS AND IMPLIED, INCLUDING WITHOUT LIMITATION ANY IMPLIED WARRANTIES OF MERCHANTABILITY, FITNESS FOR A PARTICULAR PURPOSE OR NON-INFRINGEMENT OF THIRD PARTY INTELLECTUAL PROPERTY RIGHTS.

These resources are intended for skilled developers designing with TI products. You are solely responsible for (1) selecting the appropriate TI products for your application, (2) designing, validating and testing your application, and (3) ensuring your application meets applicable standards, and any other safety, security, regulatory or other requirements.

These resources are subject to change without notice. TI grants you permission to use these resources only for development of an application that uses the TI products described in the resource. Other reproduction and display of these resources is prohibited. No license is granted to any other TI intellectual property right or to any third party intellectual property right. TI disclaims responsibility for, and you will fully indemnify TI and its representatives against, any claims, damages, costs, losses, and liabilities arising out of your use of these resources.

TI's products are provided subject to [TI's Terms of Sale](#) or other applicable terms available either on [ti.com](https://www.ti.com) or provided in conjunction with such TI products. TI's provision of these resources does not expand or otherwise alter TI's applicable warranties or warranty disclaimers for TI products.

TI objects to and rejects any additional or different terms you may have proposed.

Mailing Address: Texas Instruments, Post Office Box 655303, Dallas, Texas 75265  
Copyright © 2023, Texas Instruments Incorporated