

REV.	DATE	ECR.NO	DESCRIPTION
A	06/05/03	--	UPDATE DRAWING FORMAT
B	11/18/03	--	MODIFY MOUNTING POST
C	02/01/10	2012	HARDWARES REMOVED

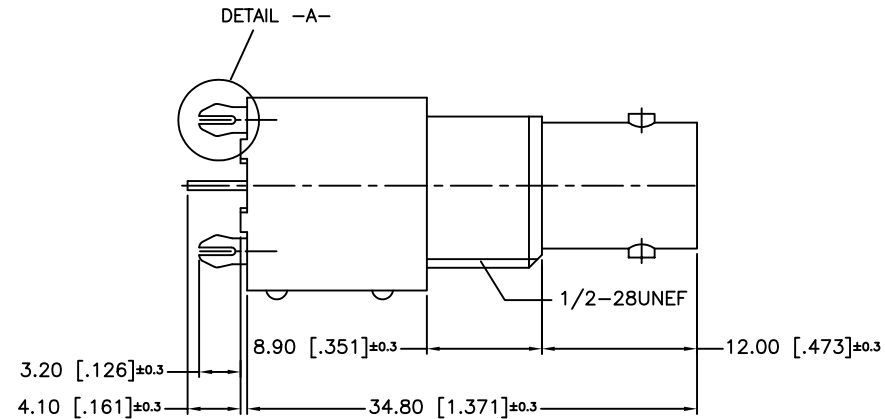
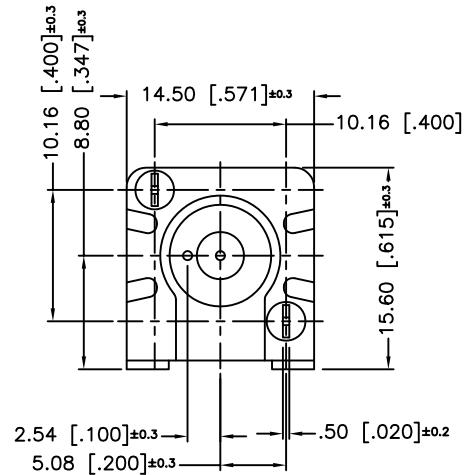
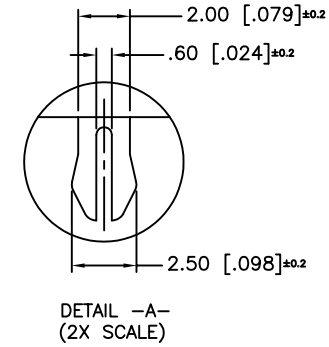
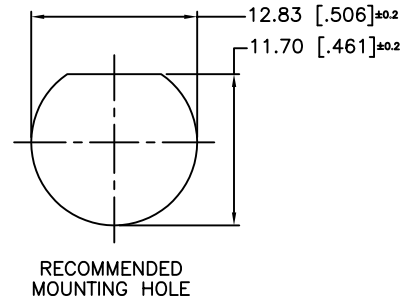
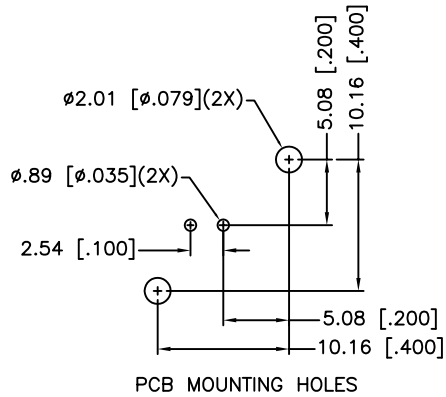

NOTE:
1. MAX. PANEL THICKNESS = 5mm

DESCRIPTION	MATERIAL	FINISH	QTY	UNLESS OTHERWISE SPECIFIED DIMENSIONS ARE IN MILLIMETERS. DIMENSIONS IN [] ARE IN INCHES AND FOR CUSTOMER REFERENCE ONLY.	APPROVALS	DATE	Amphenol Connex				
5	MOUNTING POST	BRASS	NICKEL	1	UNLESS OTHERWISE SPECIFIED TOLERANCES FOR MILLIMETERS ARE: 0.5 - 8mm ± 0.20mm 8 - 30mm ± 0.40mm 30 - 120mm ± 0.50mm UNLESS OTHERWISE SPECIFIED TOLERANCES FOR INCHES ARE: .020 - .315 = ± 0.007" .315 - 1.180 = ± 0.015" 1.180 - 4.724 = ± 0.020" DO NOT SCALE DRAWING	DRAWN CLEMENT CHECKED ISSUED SHEET 1 OF 1 CAD FILE C:/112/112408.DWG	02/01/2010	PART DESCRIPTION			
4	CONTACT PIN	PHOS. BRONZE	GOLD	1		BNC PCB MOUNT RECEPT. JACK					
3	INSULATOR	P.P.	NATURAL	1		PART NO.					
2	BODY	ZINC DIECAST	NICKEL	1		112408					
1	HOUSING	P.P.	WHITE	1		DWG. NO. 112408.DWG					
					REV. C	SIZE A	SCALE NA				