

NOTES:

- MATERIALS AND FINISHES:  
 SHELL, BODY & WASHER - BRASS, TIN-NICKEL ALLOY PLATING  
 SPRING - BeCu, TIN-NICKEL ALLOY PLATING  
 CONTACT - BeCu, GOLD PLATING  
 BULLET CONTACT - BRASS, GOLD PLATING  
 INSULATOR - PTFE, NATURAL  
 INSULATOR - ULTEM  
 O-RING & GASKET - SILICONE RUBBER, RED  
 FERRULE - SEAMLESS COPPER, TIN-NICKEL ALLOY PLATING  
 HEAT SHRINK TUBING - POLYOLEFIN BLACK

- ELECTRICAL:  
 A. IMPEDANCE: 50 OHM  
 B. FREQUENCY RANGE: DC - 6 GHz  
 C. VSWR: 1.30 MAX.  
 D. DIELECTRIC WITHSTANDING VOLTAGE: 1000 VRMS, MIN.

- MECHANICAL:  
 A. DURABILITY: 500 CYCLES MIN.  
 B. TEMPERATURE RANGE: -40°C TO +85°C  
 C. SALT SPRAY PER MIL-STD-202, METHOD 101, WITH FOLLOWING PARAMETERS:  
 1) TEST CONDITION B  
 2) 5% SALT SOLUTION  
 3) CYCLE REPEATED TO 720 HOURS

- PACKAGING:  
 A. QUANTITY: SINGLE PACK  
 B. MARKING: PACKAGING TO BE MARKED  
 "AMPHENOL RF, 31-6924-EE AND DATE CODE"

- CABLE ASSEMBLY INSTRUCTIONS:  
 A. TRIM CABLE AS SHOWN.  
 B. SLIDE HEAT SHRINK TUBING, FERRULE AND INSULATOR DISC ONTO CABLE.  
 C. SOLDER CABLE CENTER CONDUCTOR TO BULLET CONTACT.  
 D. INSERT CABLE WITH FOIL ENTERING CONNECTOR AND BRAID OVER KNURL.  
 E. CRIMP FERRULE OVER BRAID WITH 0.213" HEX DIE.  
 F. APPLY HEAT SHRINK TUBING OVER FERRULE.  
 G. HEAT SHRINK TUBING SHOULD FULLY (360 DEG) COVER THE BUMP ON BODY AND END WITHIN AREA "A"

- CONNECTOR RATED TO IP-67.  
 SHOWS CABLE ENTRY DIMENSIONS.

REVISIONS				
REV	DESCRIPTION	DATE	ECN	BY
A	RELEASE TO MFG.	7-Jul-22	16314	SH

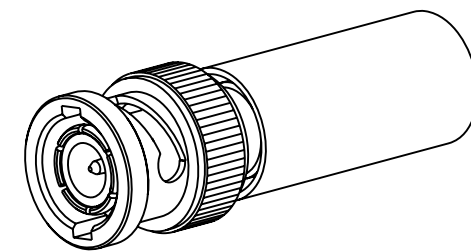

SCALE 1.500

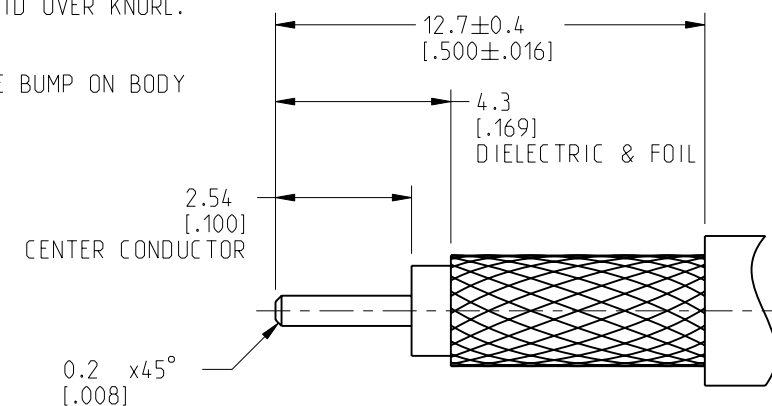

RECOMMENDED CABLE STRIPPING DIMENSIONS

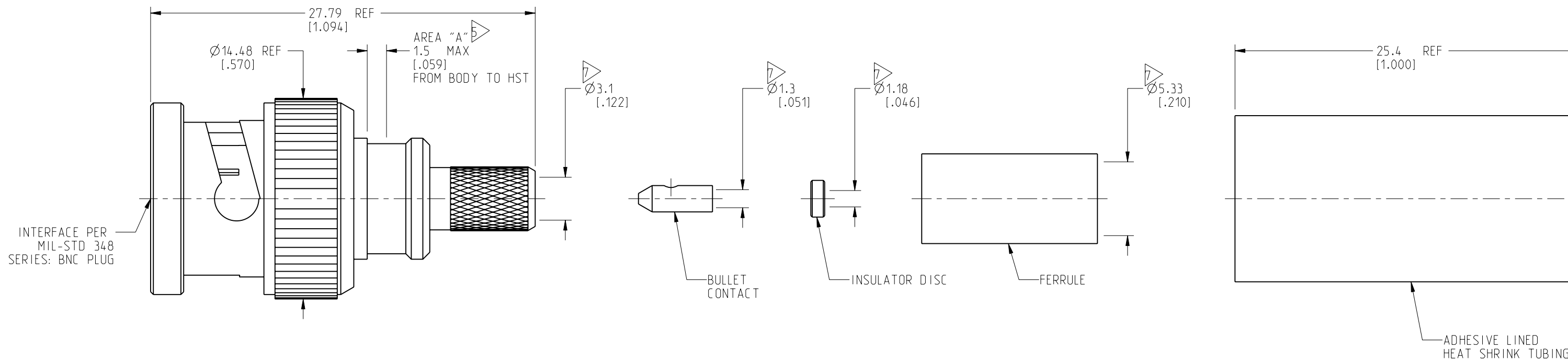

**CUSTOMER OUTLINE DRAWING**

ALL OTHER SHEETS ARE FOR INTERNAL USE ONLY

NOTICE: These drawings, specifications, or other data (1) are, and remain the property of Amphenol corp. (2) must be returned upon request; and (3) are confidential and not to be disclosed to any person other than those to whom they are given by Amphenol Corp. The furnishing of these drawings, specifications, or other data by Amphenol Corp., or to any other person to anyone for any purpose is not to be regarded by implication or otherwise in any manner licensing, granting rights to permitting such holder or any other person to manufacture, use or sell any product, process or design, patented or otherwise, that may in any way be related to or disclosed by said drawings, specifications, or other data.

UNLESS OTHERWISE SPECIFIED DIMENSIONS ARE METRIC (INCHES) AND TOLERANCES ARE:  
 <0.5mm = ±0.05mm [ $\pm 0.020 = \pm 0.002$ ]  
 0.5 - 6mm = ±0.1mm [ $\pm 0.020 - 0.236 = \pm 0.004$ ]  
 >6.00 - 30mm = ±0.2mm [ $\pm 0.236 - 1.181 = \pm 0.008$ ]  
 >30.00 - 120mm = ±0.3mm [ $\pm 1.181 - 4.725 = \pm 0.012$ ]

MATERIAL: SEE NOTES  
 ENGR.1: VIJI K  
 ENGR.2: WIKI  
 DATE: 23-MAY-22

TITLE: BNC STR PLUG IP 67 FOR RG 58 CABLE EXTREME EXPOSURE  
 SHEET NO. 2 OF 2  
 SCALE: 3.5:1.0

Amphenol RF  
 DRAWING NO. 31-6924-EE  
 ITEM NO. 31-6924-EE  
 PART NO. 31-6924-EE  
 REV: A

THIRD ANGLE PROJ.

REFERENCE: 31-6924  
 EAR#: 11330

ANGLES = ±1°