



MAX2642/MAX2643 Evaluation Kits

General Description

The MAX2642/MAX2643 evaluation kits (EV kits) simplify evaluation of the MAX2642 and MAX2643 low-noise amplifiers (LNAs). These kits enable testing of the devices' performance and require no additional support circuitry. The signal input and output use SMA connectors to facilitate connection of RF test equipment.

The MAX2642/MAX2643 EV kits are fully assembled with the MAX2642 or MAX2643 on board, and incorporate input matching components optimized for 900MHz operation.

Component List

DESIGNATION	QTY	DESCRIPTION
C1	1	470pF $\pm 5\%$ ceramic cap (0603) Murata GRM39X7R471K050 or Taiyo Yuden UMK107 B471KZ
C2	1	3.3pF $\pm 5\%$ ceramic cap (0603) Murata GRM39COG3R3B050
C3	0	Not installed
C4, C5	2	100pF $\pm 5\%$ ceramic caps (0603) Murata GRM39COG101J050 or Taiyo Yuden UMK107CH101JZ
C6	1	47pF $\pm 5\%$ ceramic cap (0603) Murata GRM39COG470J050 or Taiyo Yuden UMK107CH470JZ
C7	1	4.7 μ F ceramic capacitor (0805)
L1	1	8.7nH inductor (0603) Coilcraft 0603CS-8N7XJBC
R1	1	511 Ω $\pm 1\%$ resistor (0603)
R2	1	33k Ω $\pm 5\%$ resistor (0603) (MAX2642) 10k Ω $\pm 5\%$ resistor (0603) (MAX2643)
R3	0	Not installed
R4	1	0 Ω resistor
VCC, GND	2	2-pin headers
JU1	0	Not installed
JU2	1	3-pin header
RFIN, RFOUT	2	Edge-mount SMA connectors
U1	1	Maxim MAX2642EXT-T or MAX2643EXT-T IC (6-pin SC70)

Features

- ◆ Easy Evaluation of MAX2642/MAX2643
- ◆ +2.7V to +5.5V Single-Supply Operation
- ◆ RF Input and Output Matched to 50 Ω at 900MHz
- ◆ Jumper Included for Gain/Shutdown Setting
- ◆ Fully Assembled and Tested

Ordering Information

PART	TEMP. RANGE	IC PACKAGE	TOP MARK
MAX2642EVKIT	-40°C to +85°C	SC70-6	AAC
MAX2643EVKIT	-40°C to +85°C	SC70-6	AAD

Component Suppliers

SUPPLIERS	PHONE	FAX	WEB
Coilcraft	847-639-6400	847-639-1469	www.coilcraft.com
Murata Electronics	800-831-9172	814-238-0490	www.murata.com
Taiyo Yuden	800-348-2496	408-434-0375	www.t-yuden.com

Evaluate: MAX2642/MAX2643



MAX2642/MAX2643 Evaluation Kits

Quick Start

The MAX2642/MAX2643 EV kits are fully assembled and factory tested. Follow the instructions in the *Connections and Setup* section for proper device evaluation.

Test Equipment Required

- An RF signal generator capable of delivering -10dBm of output power and a frequency range covering the MAX2642/MAX2643 (800MHz to 1000MHz, for example)
- An RF spectrum analyzer that covers the operating frequency range
- A DC power supply capable of supplying +2.7V to +5.5V
- Two 50Ω coaxial cables with SMA connectors
- An ammeter to measure supply current (optional)
- A noise figure meter (optional)
- A network analyzer for measuring gain and return loss (optional)

Connections and Setup

Checking Power Gain

- 1) Connect a DC supply (preset to +3.0V) to the V_{CC} and GND terminals (through an ammeter, if desired) on the EV kit.
- 2) Set the RF generator for an output frequency of 900MHz at a power level of -30dBm. Connect the RF generator's output to the RFIN SMA connector.
- 3) Connect the coaxial cable from the RFOUT SMA connector to the spectrum analyzer.
- 4) Turn on the DC supply. The supply current should read approximately 5mA (if using an ammeter).
- 5) Activate the RF generator's output. A signal on the spectrum analyzer's display should indicate a typical gain of +17dB after accounting for cable and board losses.
- 6) Optional: For the MAX2642, set the jumper JU2 to the V_{CC} position. The power gain should now be +3.5dB.

- 7) Optional: Another method of determining gain is by using a network analyzer. This has the advantage of displaying gain vs. a swept frequency band, in addition to displaying input and output return loss. Refer to the user manual of the network analyzer for setup details.

Checking Noise Figure

Noise figure measurements on low-noise devices such as the MAX2642/MAX2643 are extremely sensitive to board and lab setup losses and parasitics. There are many techniques and precautions for measuring low noise figure. A detailed explanation of these items would exceed the scope of this document. Take into account PC board and external components loss when performing noise-figure measurements. The typical input losses on these EV kits is 0.25dB. For more information on how to perform this level of noise-figure measurement, refer to the noise-figure meter operating manual and to Hewlett Packard's application note #57-2, Noise Figure Measurement Accuracy.

Layout Considerations

Good PC board layout is an essential part of an RF circuit's design. The EV kit PC board can serve as a guide for laying out a board using the MAX2642/MAX2643. Generally, the V_{CC} node on the PC board should have a decoupling capacitor located close to the device, and additional capacitors may be needed for long V_{CC} lines. This minimizes supply coupling. Proper grounding of the GND pins is essential. Connect the GND pins to the ground plane either directly, through vias, or both.

MAX2642/MAX2643 Evaluation Kits

Evaluate: MAX2642/MAX2643

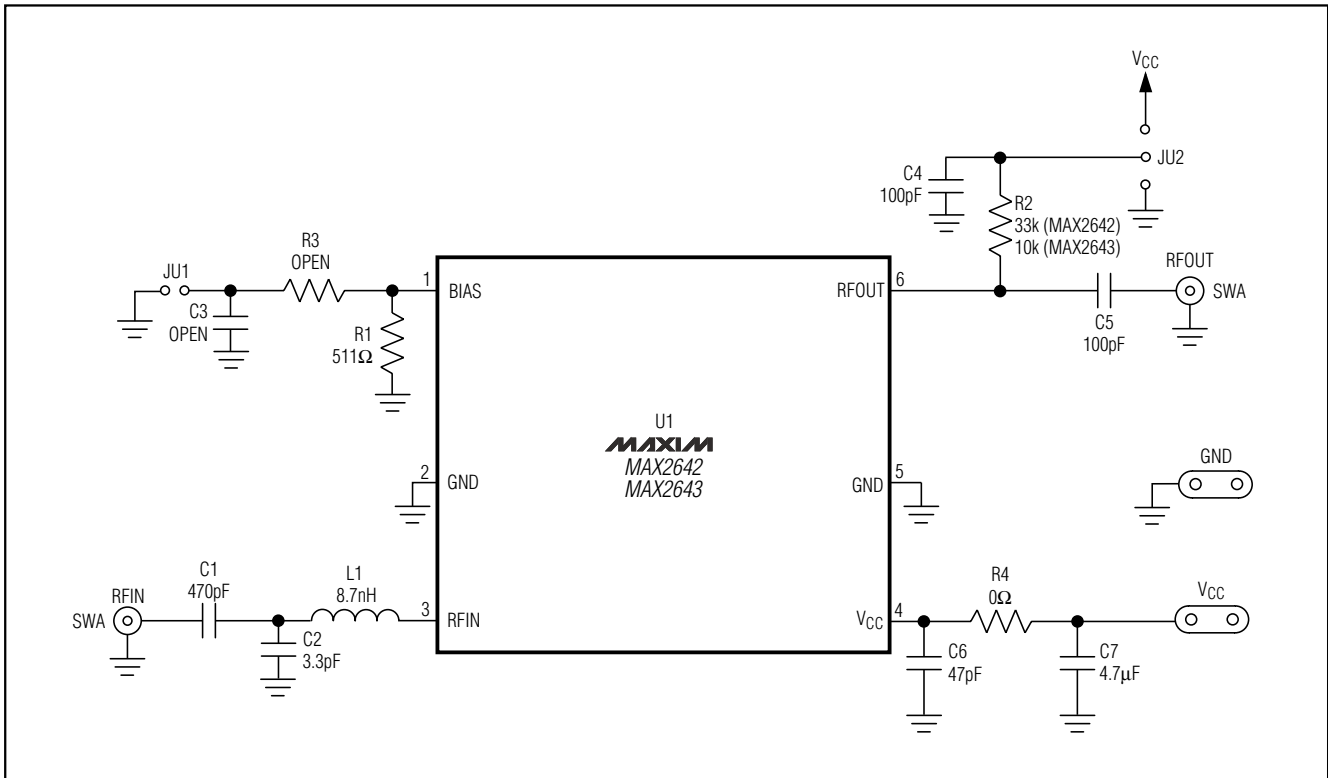

Figure 1. MAX2642/MAX2643 EV Kit Schematic

MAX2642/MAX2643 Evaluation Kits

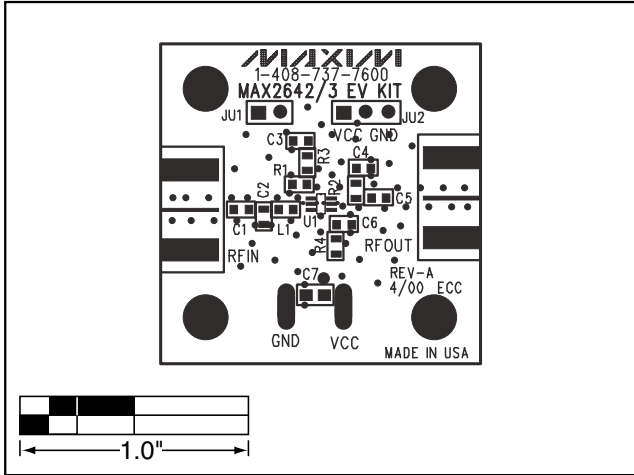

Figure 2. MAX2642/MAX2643 EV Kits Component Placement Guide—Component Side

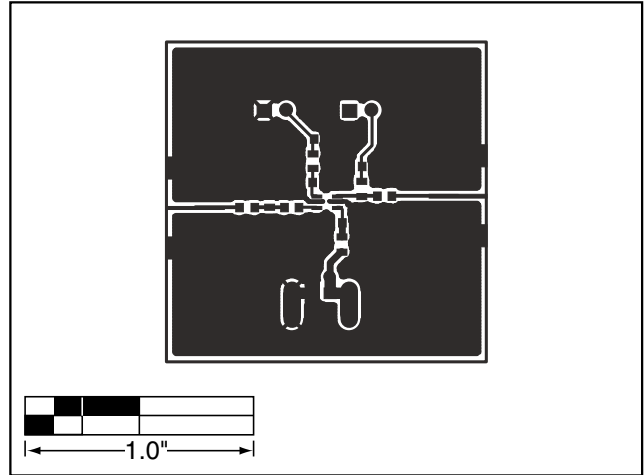

Figure 3. MAX2642/MAX2643 EV Kits PC Board Layout—Component Side

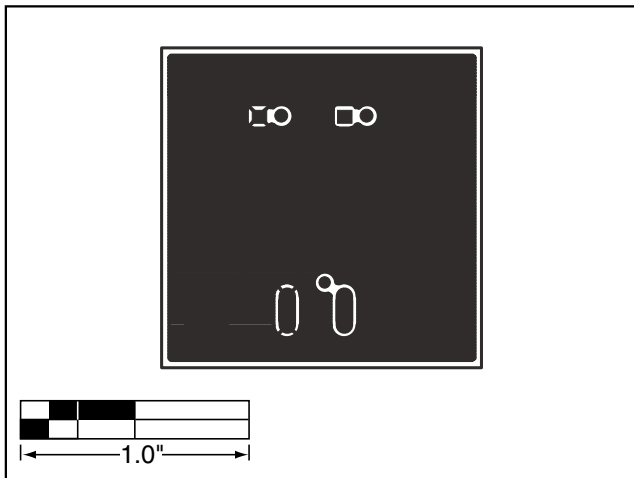

Figure 4. MAX2642/MAX2643 EV Kits PC Board Layout—Ground Plane Layers 2 and 3

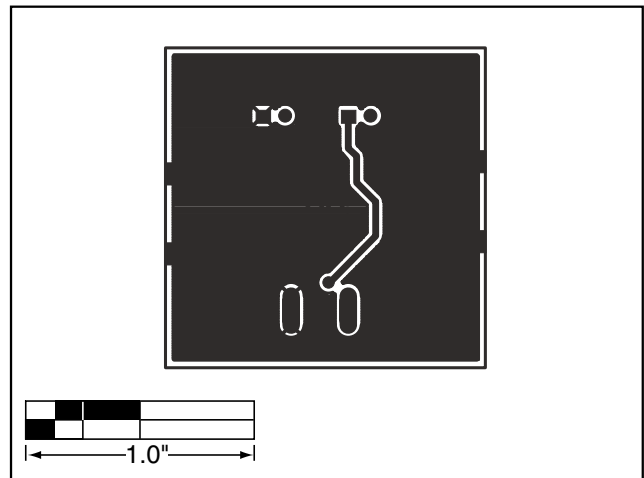

Figure 5. MAX2642/MAX2643 EV Kits PC Board Layout—Solder Side

Maxim cannot assume responsibility for use of any circuitry other than circuitry entirely embodied in a Maxim product. No circuit patent licenses are implied. Maxim reserves the right to change the circuitry and specifications without notice at any time.

4 _____ **Maxim Integrated Products, 120 San Gabriel Drive, Sunnyvale, CA 94086 408-737-7600**