

6

REMARKS: "◇" SPECIAL CHARACTERISTIC
 " + " SAFETY CHARACTERISTIC
 " () " REFERENCE ONLY

VARITRONIX LTD.		Dimension : mm	TOL : ±0.2 IF NOT SPECIFY	DD NOT SCALE DRAWING	3rd ANGLE PROJECTION
DWG. NO. : VI-402-DP0	REV : 0	Drawn by : INA	SIGN :	Date : 2004-11-11	
		Checked by : YIN	SIGN :	Date :	

DWG.NO.: VI-402-DP (REV.0)

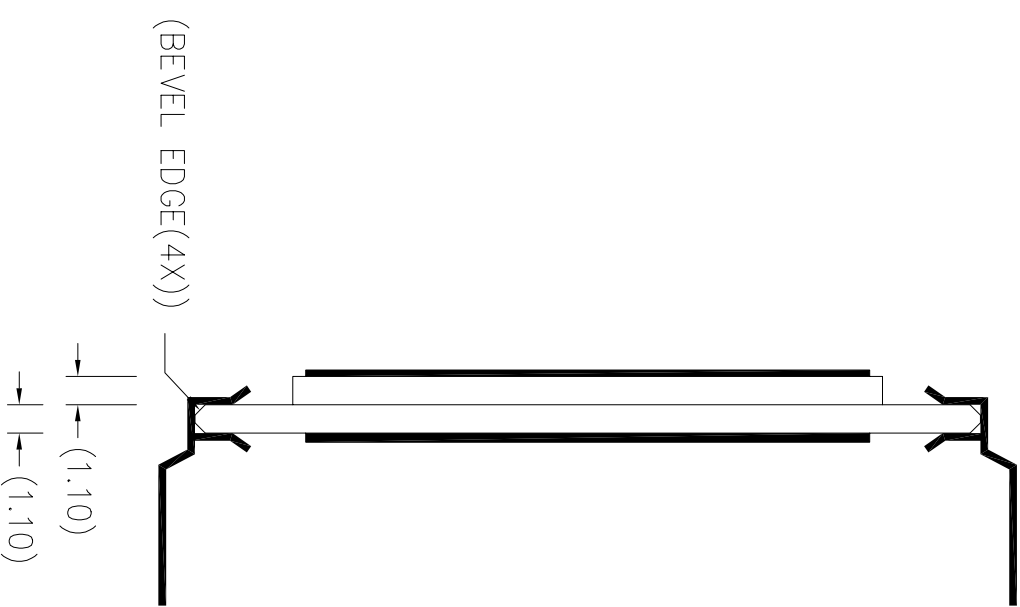
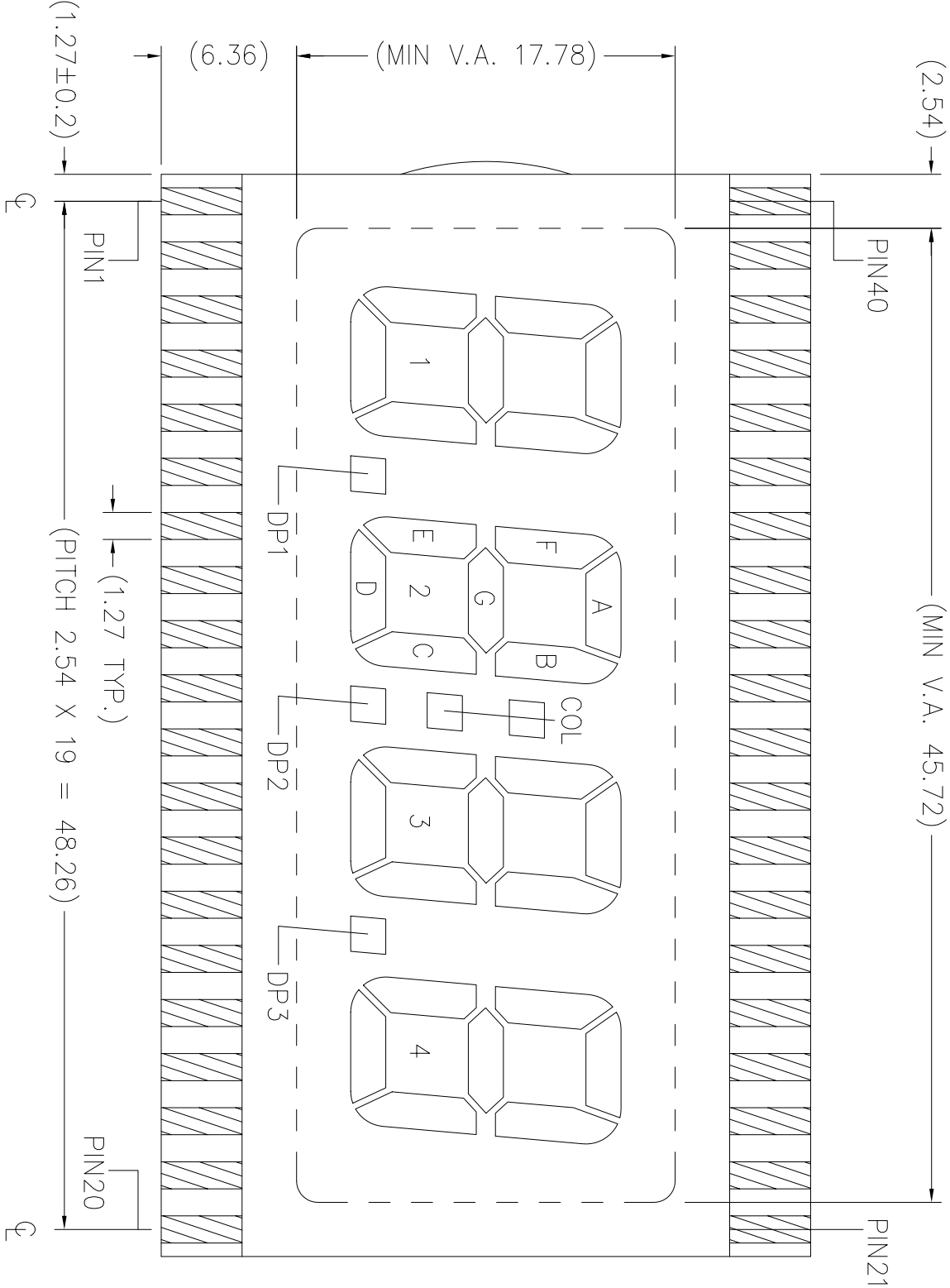

DWG. NO.: VI-402-DP (REV.0)

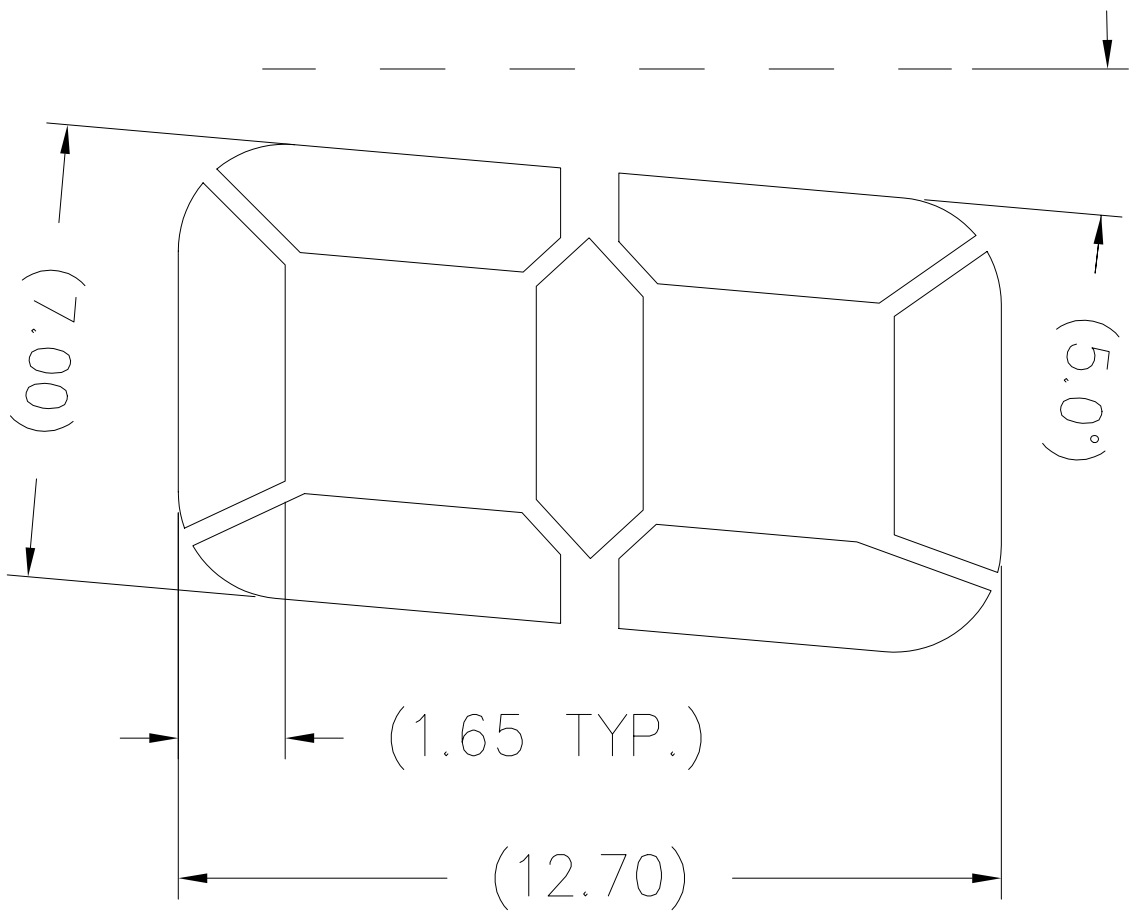

DIGIT 1-4

DWG. NO.: VI-402-DP (REV.0)

SEGMENT TRACKING

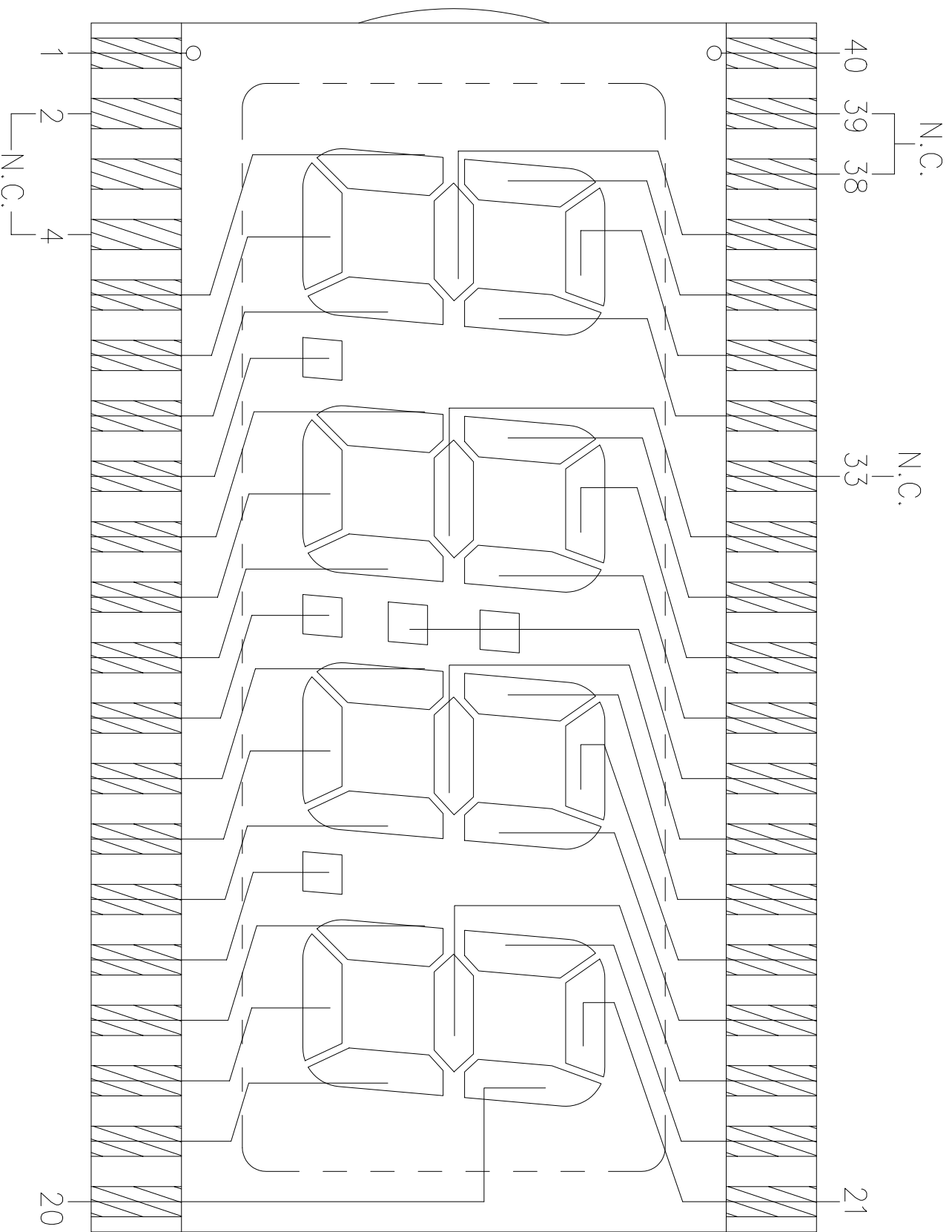

REMARKS: N.C. = NO CONNECTION

COMMON TRACKING

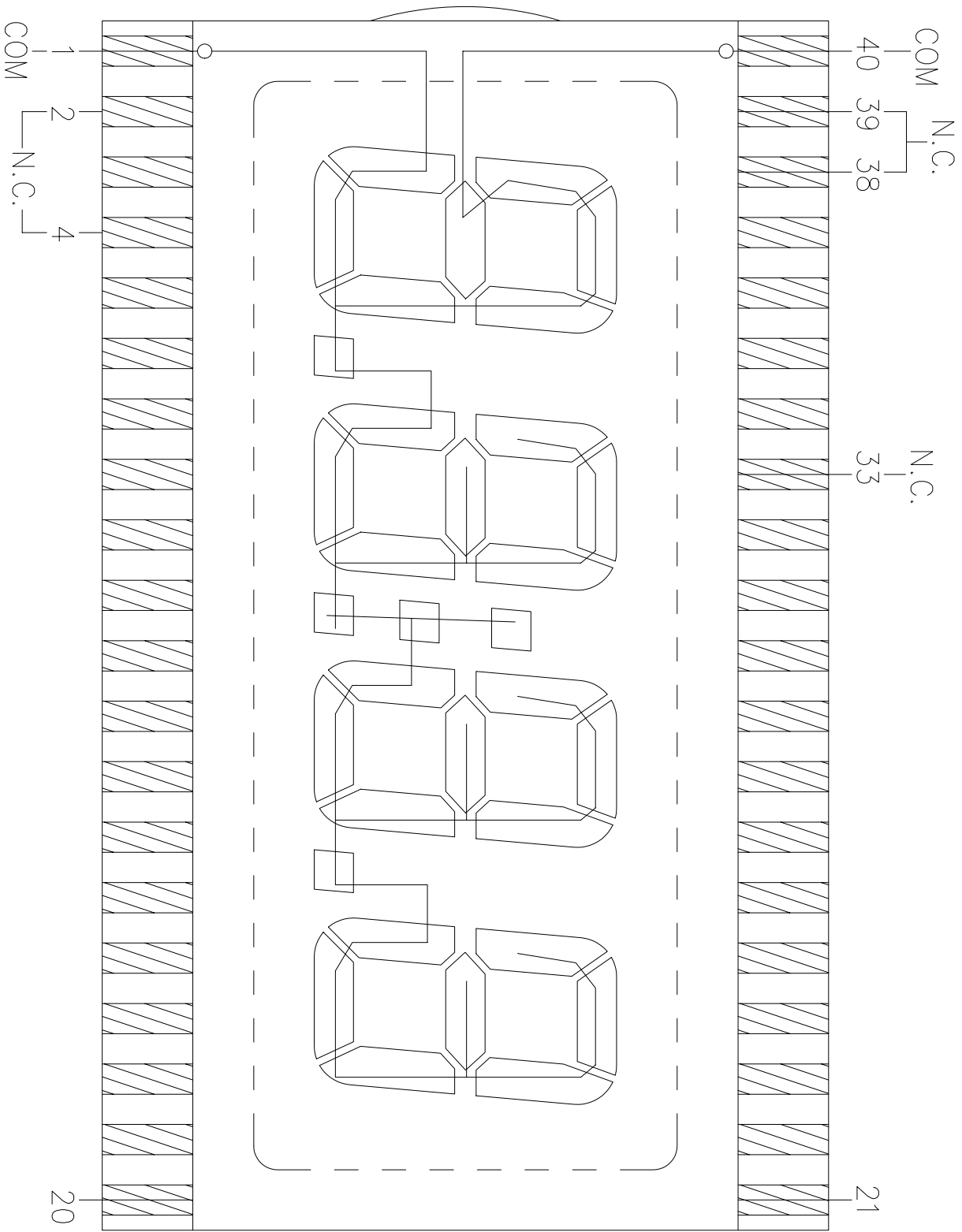

REMARKS: N.C. = NO CONNECTION

SAME COMMON SHOULD BE CONNECTED TOGETHER ON THE P.C.B.

VARTRONIX LIMITED		OPEN LAYER :	SCALE
POLARIZER LOCATION DIAGRAM		P	Do not scale
DOC. NO. : PL-VI-402-DP-01		Drawn by : INA	Date : 2004-11-12
		Checked by : INA	Date : 2004-11-12
		Approval By :	Date : 2004-11-15

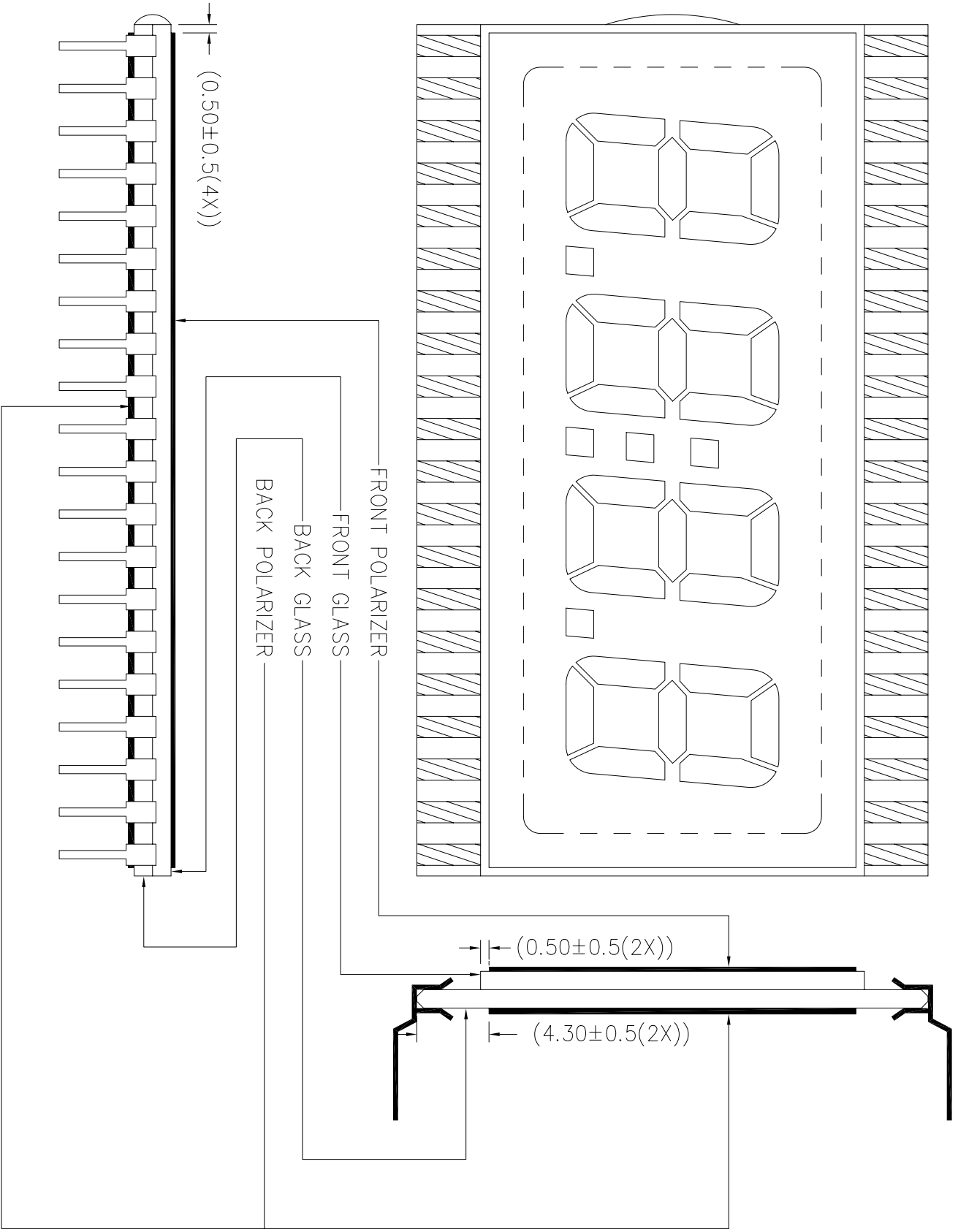

VARITRONIX LIMITED		OPEN LAYER :	SCALE
DIL-PIN DETAILS LOCATION DIAGRAM		DP-10	Do not scale
DOC. NO. : DP-VI-402-DP-01	Drawn by : INA	Date : 2004-11-12	
	Checked by : INA	Date : 2004-11-12	
ALL DIMENSIONS IN mm	Approval by :	Date : 2004-11-15	

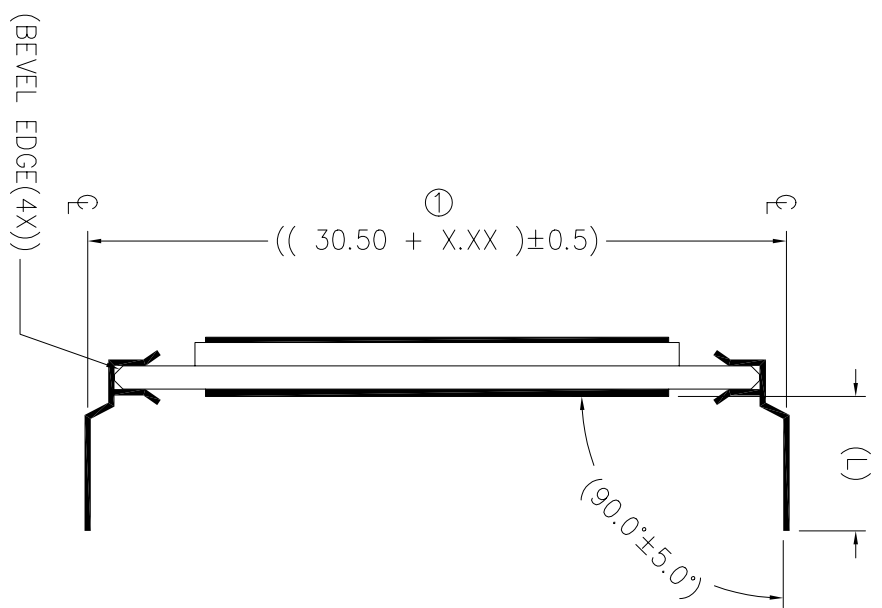
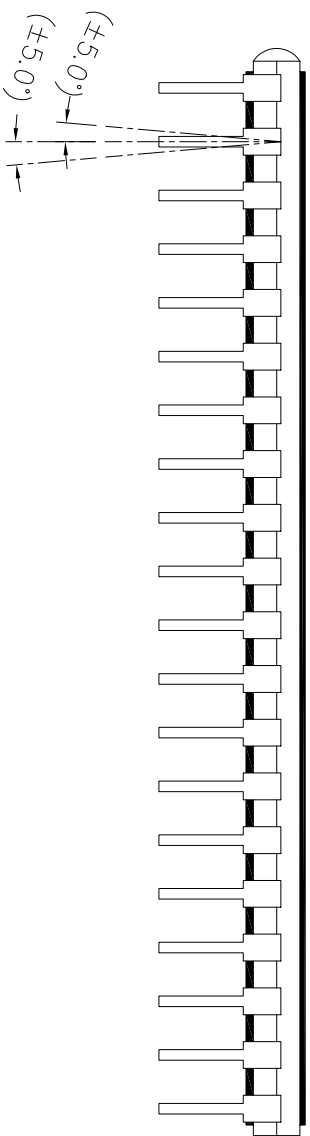
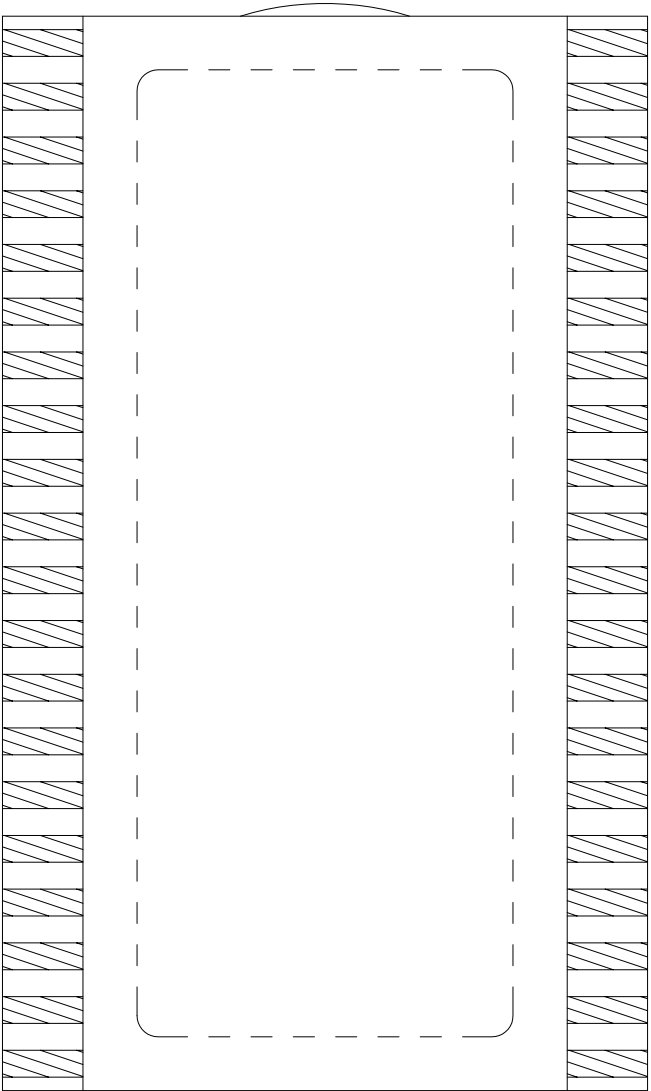

REMARKS: PIN LENGTH (L) REFER TO COVER PAGE

- ① ----- X.XX=2.54 (FOR PIN LENGTH \geq 3.20 & \leq 10.00mm)
- X.XX=1.75 (FOR PIN LENGTH $>$ 10.00 & \leq 19.50mm)

DWG.NO.: VI-402-DP (REV.0)

PIN	COM	PIN	COM
1	COM	21	4A
2	N.C.	22	4F
3	N.C.	23	4G
4	N.C.	24	3B
5	1E	25	3A
6	1D	26	3F
7	1C	27	3G
8	DP1	28	COL
9	2E	29	2B
10	2D	30	2A
11	2C	31	2F
12	DP2	32	2G
13	3E	33	N.C.
14	3D	34	1B
15	3C	35	1A
16	DP3	36	1F
17	4E	37	1G
18	4D	38	N.C.
19	4C	39	N.C.
20	4B	40	COM

REMARKS: N.C. = NO CONNECTION

SAME COMMON SHOULD BE CONNECTED TOGETHER ON THE P.C.B.