



1T16WE_1.5RP series

1W - Single/Dual Output DC-DC Converter - Fixed Input - Isolated & Regulated

DC-DC Converter 1 Watt

- + Wide input range (2:1)
- + 16Pin SMD package
- + 1.5kVDC isolation
- + High efficiency up to 85%
- + RoHS Compliance
- + Short circuit protection (SCP)

- + Operating temperature range: -40°C ~ +85°C
- + International standard pinout
- + No external component required

The 1T16WE_1.5RP Series is specially designed for applications where a wide range input voltage power supplies are isolated from the input power supply in a distributed power supply system on a circuit board.

These products apply to:

- 1) Where the voltage of the input power supply is wide range (voltage range $\leq 2:1$);
- 2) Where isolation is necessary between input and output (Isolation Voltage $\leq 1500\text{VDC}$);
- 3) Where the regulation of the output voltage and the output ripple noise are demanded.



Common specifications	
Short circuit protection:	Continuous
Temperature rise at full load:	15°C TYP
Cooling:	Free air convection
Operation temperature range:	-40°C~+85°C
Storage humidity range:	< 95% non-condensing
Case material:	DAP
MTBF:	>1,000,000 hours
Weight:	3.9g
Dimensions:	24.1x14.35x10.25mm

Output specifications						
Item	Test condition	Min	Typ	Max	Units	
Voltage tolerance				±2	%	
Line regulation	Regulated			±0.5	%	
Load regulation	Regulated			±0.8	%	
Temperature drift	100% full load			±0.02	%/°C	
Ripple & Noise	20MHz Bandwidth			60	mVp-p	
Transient response setting time	50% load step change		350		µs	
Switching frequency	Full load, nominal input		100		KHz	

Input specifications						
Item	Test condition	Min	Typ	Max	Units	
Input voltage range				2:1		
Input Filter	Capacitor					

Example:
1T16WE_0515S1.5RP
 1 = 1Watt; T16 = SMT16; W = Wide input; E = Cost effective; 5Vin; 15Vout; S = Single output; 1.5 = 1.5kVDC; R = Regulated output; P = Short circuit protection (SCP)

Isolation specifications						
Item	Test condition	Min	Typ	Max	Units	
Isolation voltage		1500			VDC	
Isolation resistance	500VDC	1000			MΩ	

Note:

1. Unless otherwise specified, data in this data sheet should be tested under the conditions of Ta = 25°C, nominal input voltage and rated output current;
2. All index testing methods in this datasheet are based on our Company's corporate standards.

1T16WE_1.5RP series

1W - Single/Dual Output DC-DC Converter - Fixed Input - Isolated & Regulated

Product Selection Guide

Part Number	Input Voltage Range [V]	Output Voltage [VDC]	Output current [mA]	Efficiency [%; Typ]
1T16WE_0503S1.5RP	4.5-9	3.3	303	68
1T16WE_0505S1.5RP	4.5-9	5	200	71
1T16WE_0512S1.5RP	4.5-9	12	84	73
1T16WE_0515S1.5RP	4.5-9	15	67	71
1T16WE_1203S1.5RP	9-18	3.3	303	71
1T16WE_1205S1.5RP	9-18	5	200	75
1T16WE_1212S1.5RP	9-18	12	84	78
1T16WE_1215S1.5RP	9-18	15	67	78
1T16WE_2403S1.5RP	18-36	3.3	303	71
1T16WE_2405S1.5RP	18-36	5	200	78
1T16WE_2412S1.5RP	18-36	12	84	82
1T16WE_2415S1.5RP	18-36	15	67	83
1T16WE_4803S1.5RP	36-75	3.3	303	70
1T16WE_4805S1.5RP	36-75	5	200	74
1T16WE_4812S1.5RP	36-75	12	84	80
1T16WE_4815S1.5RP	36-75	15	67	80
1T16WE_0505D1.5RP	4.5-9	±5	±100	68
1T16WE_0512D1.5RP	4.5-9	±12	±42	70
1T16WE_0515D1.5RP	4.5-9	±15	±34	71
1T16WE_1205D1.5RP	9-18	±5	±100	71
1T16WE_1212D1.5RP	9-18	±12	±42	78
1T16WE_1215D1.5RP	9-18	±15	±34	76
1T16WE_2405D1.5RP	18-36	±5	±100	74
1T16WE_2412D1.5RP	18-36	±12	±42	78
1T16WE_2415D1.5RP	18-36	±15	±34	80
1T16WE_4805D1.5RP	36-75	±5	±100	74
1T16WE_4812D1.5RP	36-75	±12	±42	77
1T16WE_4815D1.5RP	36-75	±15	±34	78

Typical characteristics

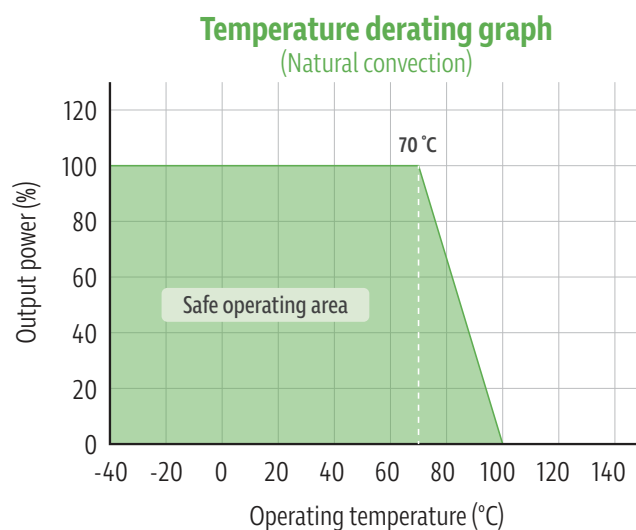

1T16WE_1.5RP series

1W - Single/Dual Output DC-DC Converter - Fixed Input - Isolated & Regulated

Recommended test circuit

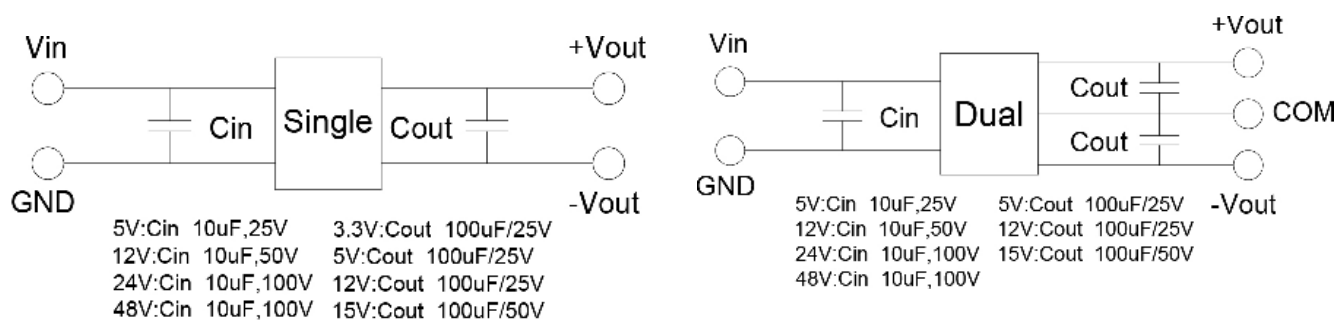

Mechanical dimensions

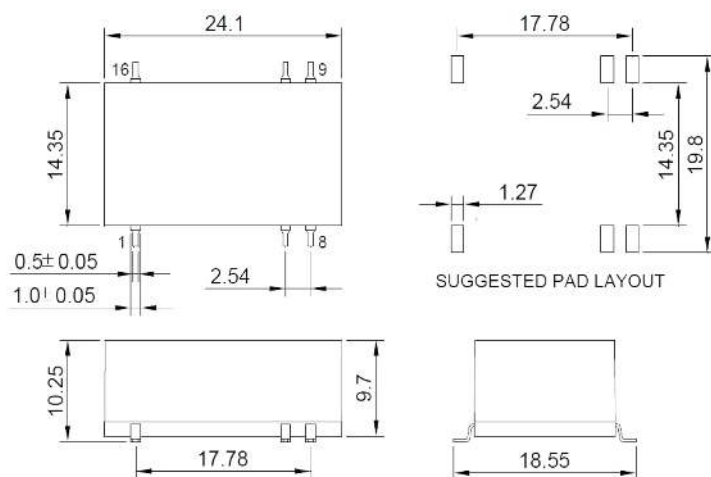

UNIT:mm Unless otherwise specified,all tolerances are ±0.25

PIN	1	7	8	9	10	16
SINGLE	-Vin	NC	NC	+Vout	-Vout	+Vin
DUAL	-Vin	NC	Com	+Vout	-Vout	+Vin