

- △ HOUSING-MATERIAL : LIQUID-CRYSTAL-POLYMER, COLOR:NATURAL.
- △ CONTACT-MATERIAL : PHOS. BRONZE.
- △ LATCH-MATERIAL : BRASS, NICKEL PLATE.
- △ CONTACT-PLATE 0.00127 [.000050] MIN NICKEL ALL OVER.
- △ CONTACT-PLATE 0.00076 [.000030] MIN. GOLD AT CONTACT PTS.
- △ CONTACT SOLDERDETAILS-PLATE 0.00508 [.000200] MIN TIN/LEAD.
- 7. IN ADDITION TO THOSE RECOMMENDED "SIMM" P.C. BOARD DIMENSIONS AND TOLERANCES SHOWN, ALL JEDEC SPECIFICATIONS APPLY AS SHOWN ON MO-116, ISSUE A.
- 8. RECOMMENDED MATING S.I.M.M. TAB METALLURGY: BASE METAL-COPPER. PLATING TO BE 0.00076 [.000030] MIN GOLD OVER 0.00127 [.000050] MIN NICKEL.
- 9. OBSOLETE
- 10. DATE CODE: (YEAR WEEK) XXXX FORMAT, LOCATED APPROXIMATELY AS SHOWN ON OPPOSITE SIDE.

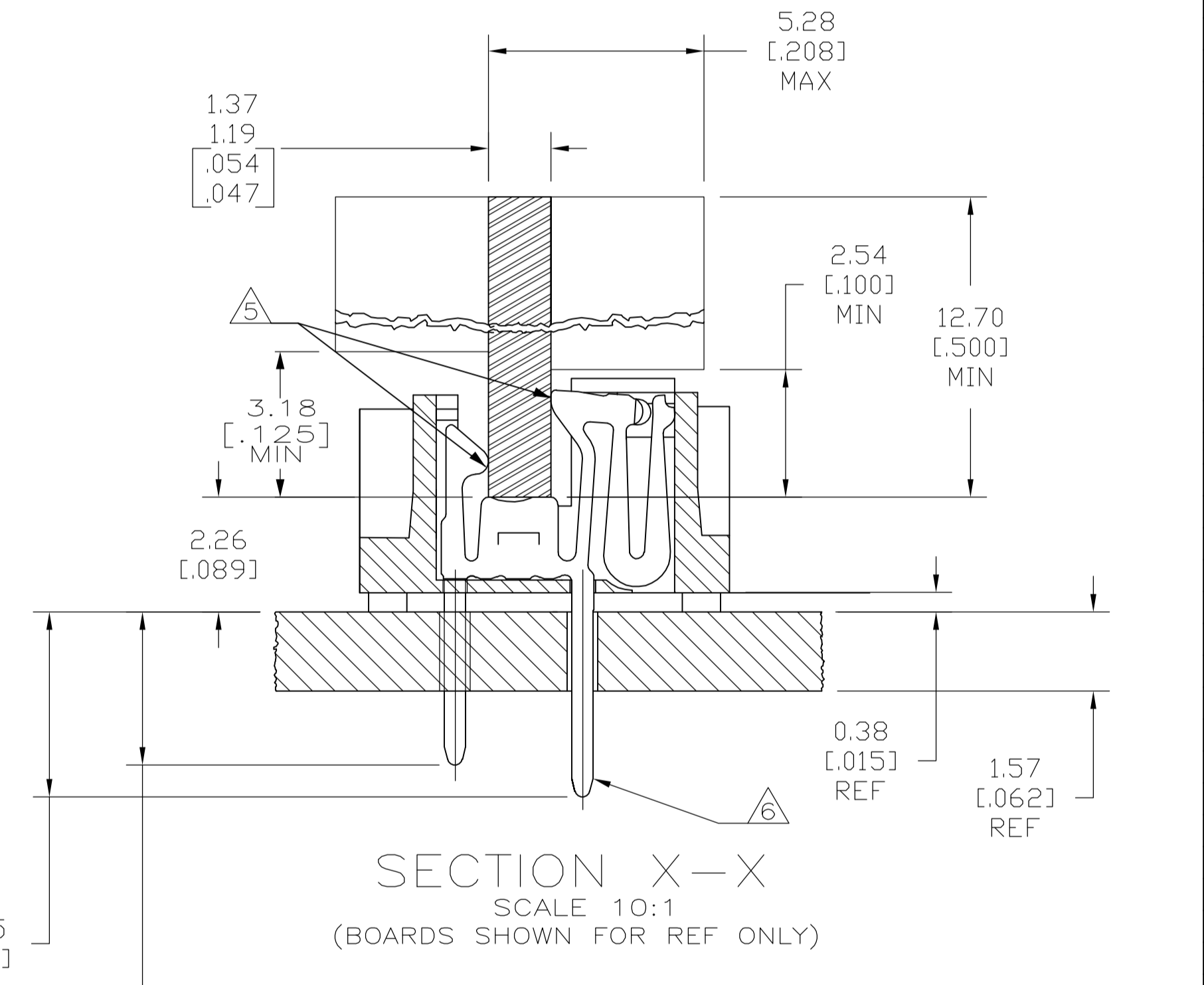

143.51[5.650]	136.75[5.384]	73.66[2.900]	62.23[2.450]	151.13[5.950]	130.81[5.150]	100	△ 822031-6
118.11[4.650]	111.35[4.384]	60.96[2.400]	49.53[1.950]	125.73[4.950]	105.41[4.150]	80	△ 822031-5
107.95[4.250]	101.19[3.984]	55.88[2.200]	44.45[1.750]	115.57[4.550]	95.25[3.750]	72	822031-4
102.87[4.050]	96.11[3.784]	53.34[2.100]	41.91[1.650]	110.49[4.350]	90.17[3.550]	68	△ 822031-3
97.79[3.850]	91.03[3.584]	50.80[2.000]	39.37[1.550]	105.41[4.150]	85.09[3.350]	64	△ 822031-2
67.31[2.650]	60.55[2.384]	35.56[1.400]	24.13[.950]	74.93[2.950]	54.61[2.150]	40	△ 822031-1
F	E	D	C	B	A	NO OF POSN	PART NO

THIS DRAWING IS A CONTROLLED DOCUMENT.

DIMENSIONS: mm [INCHES]	TOLERANCES UNLESS OTHERWISE SPECIFIED:	DWN S. WAITMAN 6JAN05		Tyco Electronics Corporation Harrisburg, PA 17105-3608						
0 PLC ± -	1 PLC ± -	2 PLC ± -		3 PLC ± 0.13[.005]	4 PLC ± -	ANGLES ± -	APVD M. YFOMANS 6JAN05	NAME	CONNECTOR, MICRO-EDGE, .050, VERTICAL, GOLD PLATE, METAL LATCH	
MATERIAL	FINISH	WEIGHT	SIZE A1	DATE CODE 00779	DRAWING NO C=822031	RESTRICTED TO	CUSTOMER DRAWING	SCALE 4:1	SHEET 1 of 1	REV N