

Capacitive Sensor Control IC Series

Capacitive Sensor Switch Control IC



BU21008MUV

No.09048EBY01

●Note in capacitive sensor board design

Here, it explains a recommended value and recommended condition concerning the board, the overlay, and mounting when BU21008MUV of capacitive sensor IC series and the composition by a solid board are assumed.

It is not the one to do the operation guarantee though a recommended value and recommended condition are made based on the result of the real machine experiment by an experimental board. On the other hand, it is not the one to fix immovable when not satisfying it either.

It treats as a reference of an initial examination, and finally, please experiment the principle by the use of a real machine, and judge the quality of the system by the mounting experiment.

• Board

Item	Material	Numerical value	Other condition
Board material	FR4 (glass epoxy)	thickness =1.6mm or more	2 layer both sides structure
Electrode material	Cu	thickness =10um-50um	-
Electrode size	-	36mm over - finger contact area twice or less	-
Electrode form	-	-	Shape doesn't influence sensitivity
Wiring width	Cu	0.2mm or less	The minimum value of the design rule of the board is applied
Wiring length	Cu	100mm or less	-
Via size	Cu	0.4mm or less	The minimum value of the design rule of the board is applied

1) About the size of the sensor electrode

- ①The area of the sensor must do Hi and become twice or more the gross area of wiring.
- ②Please give the twice the contact side product of the assumed finger to the upper bound of the area of the sensor as a standard.
- ③Please give 36mm² to the lower bound of the area of the sensor as a standard.

2) About the form of the sensor electrode

- ①The shape of the sensor doesn't have a big influence in the sensitivity of the sensor.
Given the shape of the finger-like circular and rectangular, and is appropriate.
- ②The design with the copyright like the registration of a design etc. exists, and note special shape, please.

3) Method of setting up sensor electrode and wiring

- ①The grand area arrangement around the sensor electrode and the sensor wiring is recommended.
Please arrange a grand area in the same to sensor electrode layer, and open the gap between a sensor electrode and grand area by 1.0mm or more (To decrease a parasitic capacitance increase).
- ②The grand area arrangement in the back of the sensor electrode and wiring is recommended.
Please arrange a grand area to cover all opposed the sensor electrodes with another layer on the back side of the sensor electrode. The device that suppresses a parasitic capacitance increase such as grand shape being made a mesh is necessary following the thickness 1.6mm in the FR4 board. In that case, please consult separately.

• Overlay

Item	Material	Numerical value	Other condition
Overlay material	Acrylic , glass	thickness =1.3mm or less	High dielectric constant material
Decorative material coat	nonconductive	thickness =50um or less	The content of a metallic material is noted
Decorative material deposition plating	low tin and deposition of conductive metal plating	thickness =50um or less	-

1) About the overlay material

In the resin system, the acrylic fiber is recommended. In the inorganic system, the glass is recommended. The material with a high permittivity is recommended to be used.

2) The decorative metal-coating material on the carbon content and the volume of film and the low resistance, the sensor can cause a loss of sensitivity. If you want to study painting, paint containing a conductive material and content of the confirmation of whether the content of the variations (on mass) of the sample prepared please check acceptance.

3) By metal-plated decorative materials for the deposition

- ① It is possible to make the sensor react by depositing the material of low conductive as tin in discontinuity. When a metallic deposition is examined, I hope a panel manufacturer and prior meeting.
- ② Will be decorating for the electrode surface, touch sensors at the bottom of a multi-electrode reaction at the same time a situation occurs. Specifications for the film by evaporation the degree of impact varies, but as a fundamental measure, the decorative film without a solid arrangement, the top surface of the sensor in the outer groove established electrical, adjacent to the separation of electrical sensors to each other to make a film that is recommended.

• Mounting

Item	Material	Numerical value	Other condition
Fixed material	Double-faced tape	thickness = 100um or less	-

1) About a fixed material

- ① Both sides must use the one of the composition that is the base material for the center for specification with the adhesive especially like a no bur and the double-faced tape, etc. for the material, please use 100 um in total thickness following.
- ② The thickness of the air-gap when bonding is canceled by the calibration function in case of 100um or less. It is possible to correct it even by the one by a change with the lapse of time because it is done at the time of not the setting done to the first stage of manufacturing but each power supply turning on.

2) Sensors on board sensors fixed to the board at the top of double-sided tape at the Ministry of fixed overlay method is recommended.

Department back on board, Board recommended conditions (FR4 material, thickness = 1.6mm or more) points if you do not pay attention to the special. If you have a thin or thick board, FPC and stability of shape if not, back to the structural changes in fixed to reduce the parasitic capacitance to charity is required.

● OK NG example of wiring pattern

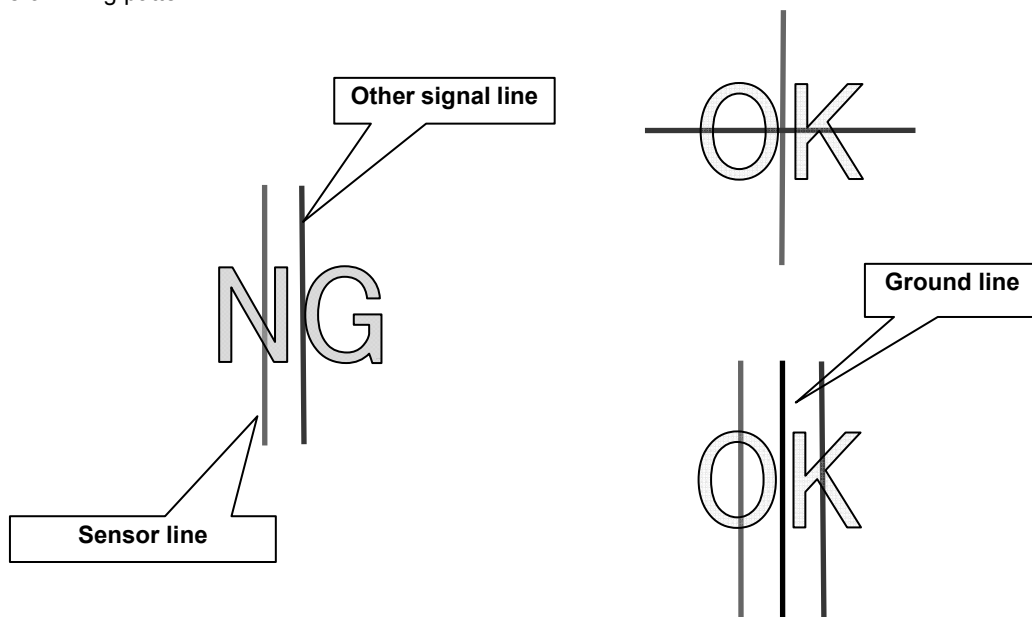

●SREF electrode

1) In case SREF (reference electrode) has a same area as sensor electrode.

In case SREF electrode is placed on a surface of sensor electrode, it has to be placed with a certain distance from the noise source and the finger contact influence. When it is placed on the back side of the sensor electrode surface, same caution must be taken.

Most recommended configuration is to place it into middle layer which are covered by ground area (both front and back side surface).

2) In case capacitor is used.

When a capacitor is used as a SREF (reference electrode), please place capacitor in the LSI component side as close as possible.

The selection of the capacitance value has to be determined by experiment/tuning. In a commonly used PCB material (no middle connection components such as connectors), under 1 to 10pF is recommended. In conversion theory, because the capacity value near the DC is expected and there is a calibration of the offset cancellation circuit, the capacitor accuracy as well as the temperature characteristics can be satisfied with standard capacitor products.

●Calibration

There are 16 sensor ports in BU21008MUV able to use. In the BU21008MUV, Only even ports can calibrate difference of the capacitance between the two sensors to correct. The odd ports will use a result of the even ports that executed calibration. An ideal value of the 8bitADC that the calibration was executed is near to 128.

After calibration, the ADC value that first sense is an offset correction data and is kept in register OFFSET (4*h). An offset value will be the difference between the offset correction data and center value 128.

The offset value will keep the ADC value center value 128 when the sensor was not touched.

$$\text{Offset value} = \text{Offset correction data (4*h)} - 128$$

If the offset correction data is less than 128, it is meaning SREF > SIN. (Gain x1)

If the offset correction data is more than 128, it is meaning SREF < SIN. (Gain x1)

As for the channel not corrected, the error margin of the offset correction value grows compared with the corrected channel. Because correction value obtained with other channels is misappropriated.

Without exceeding the threshold value of turning on not moving at all can happen when this error margin is large.

1) The channel that doesn't do the calibration must be nearer IC than the channel that does the calibration.

2) SREF setting

The offset value of SIN1, 3, 5, 7, 9, 11, 13, 15(register address 40h – 4Fh) < 128

Adjust the highest one in SIN1 and SIN3, 5, 7, ... SIN15 approach 128

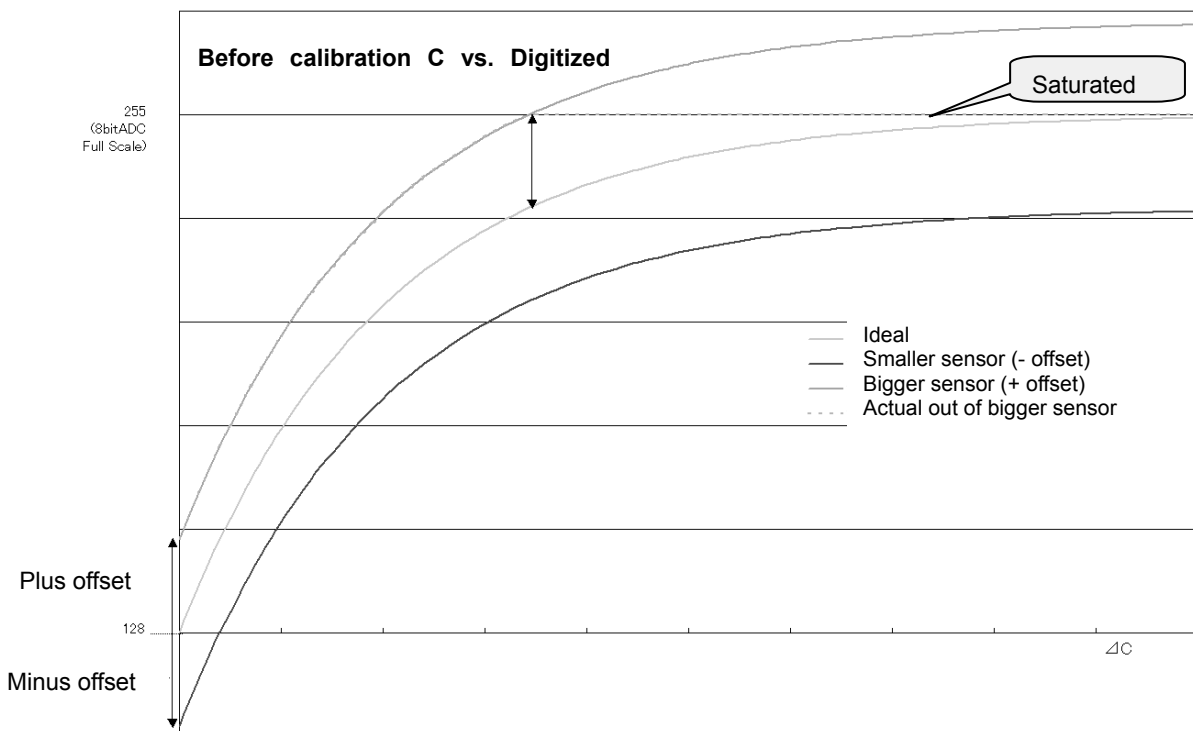

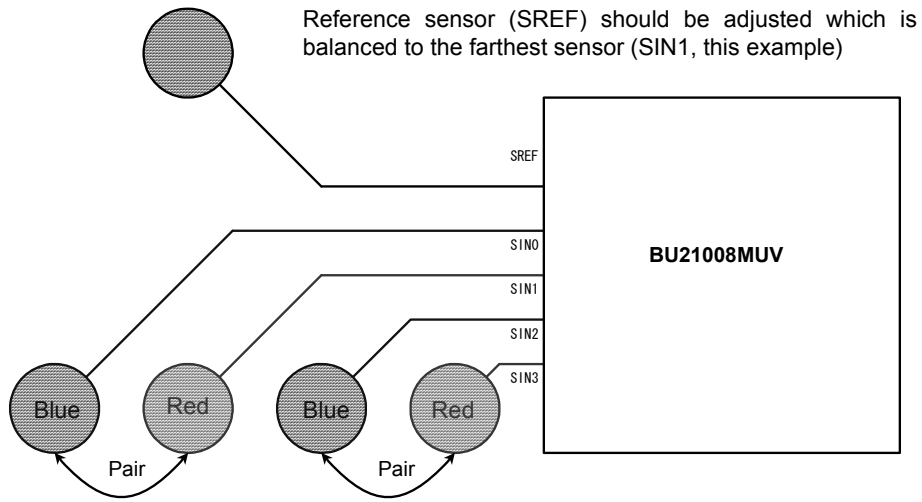

Blue: Calibrated channel
 Red: Non-calibrated channel
 Non-calibrated channel should be nearer to IC than calibrated channel

Example) The switch application of 6ch
 Use the channel that does the calibration by priority. (SIN0, SIN2, SIN4, SIN6)
 SIN1, SIN3 wiring: SIN0 > SIN1, SIN2 > SIN3

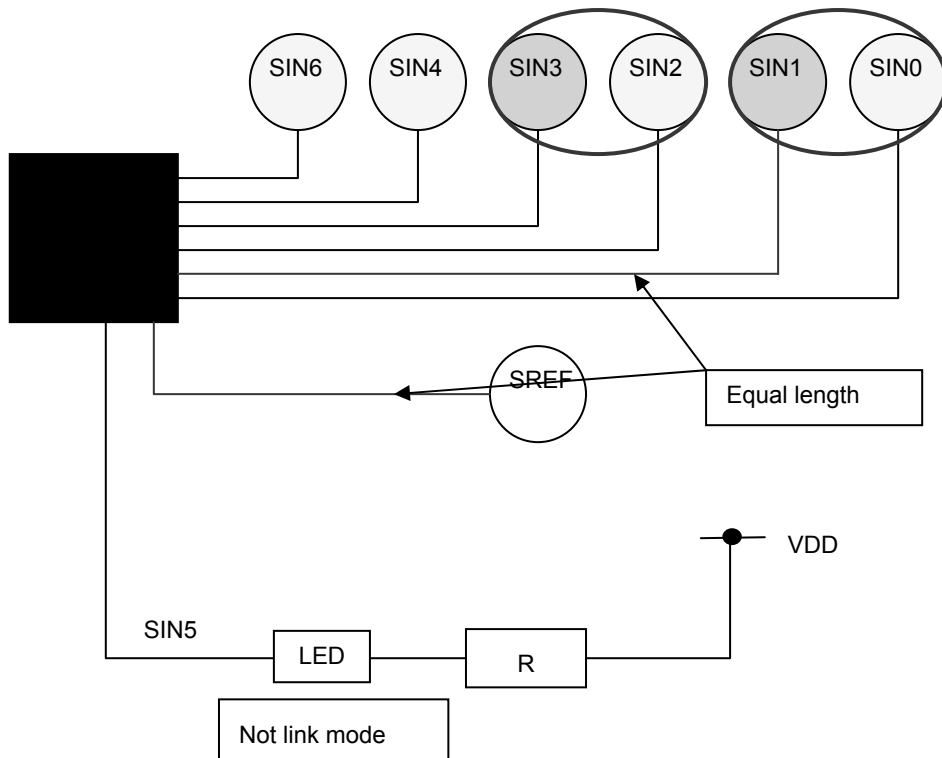

● Application circuit

The following figure illustrated the application circuit of BU21008MUV.

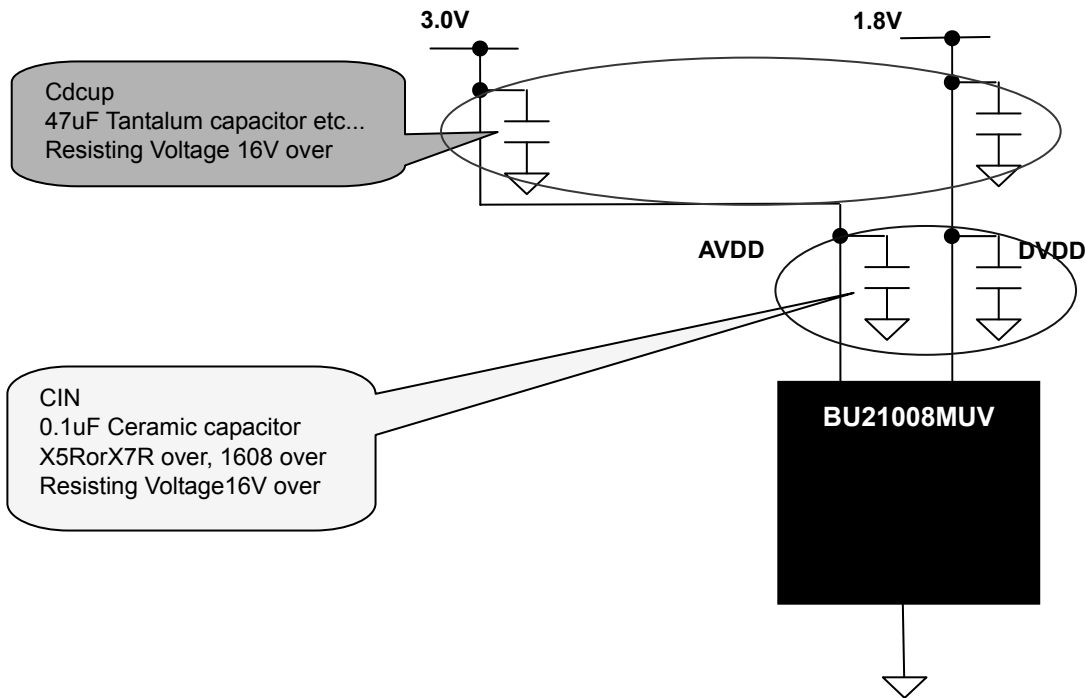

- 1) IC electrostatic times to pull the power to make the layout upstream AVDD please.
- 2) Control the branching paths after entering the terminal layout to please the most recent.
- 3) Recommended circuit, the real validation, please always done.

BU21008MUV Digital pins

There are several I/F settings of the BU21008. The following illustrated to define the digital pins.

- 1) TSTD(17) : Tide to "L". Prefer to pull down.
- 2) TSTA(13) : Open. Prefer to allocate a ground area around this pin.
- 3) MODE0(15)/MODE1(16): H or L. prefer to make the pins changeable.
- 4) RXD(22) : Tide to "L". In I2C mode, it does not use.
- 5) CS(23) : Tide to "H/L". In I2C mode, it is able to select the slave address. prefer to make the pins changeable.
- 6) CLK_EXT (18): External system clock input. When the controller uses internal clock, must tide it to "H/L".

● Application circuit example

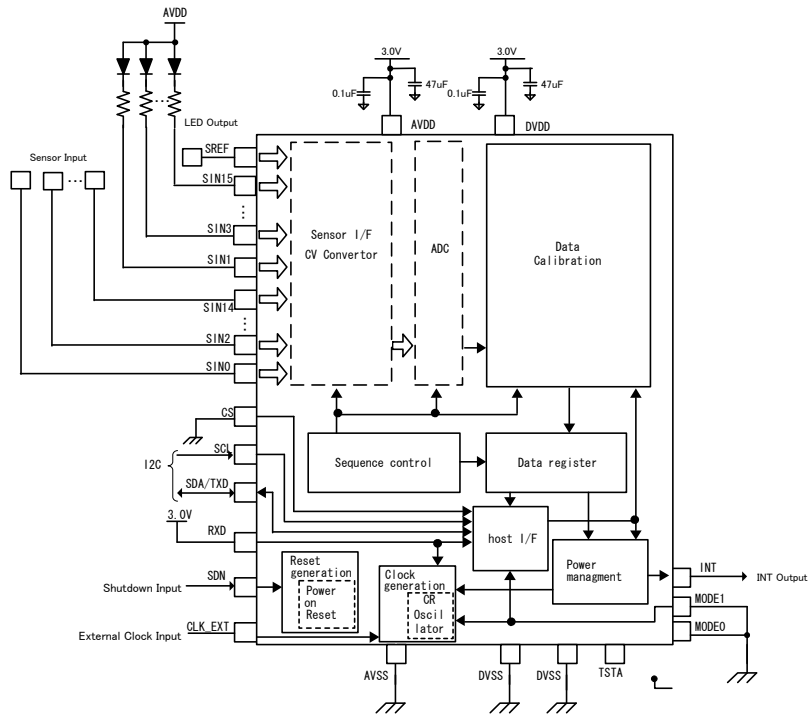

External clock mode

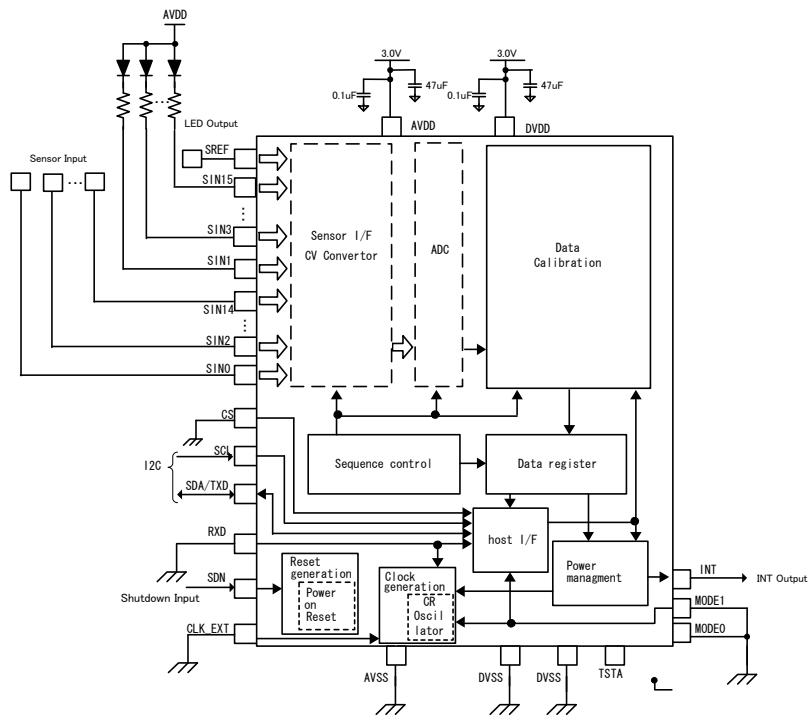

Internal clock mode

●Power Supply

BU21008MUV have 2 kinds of power supply pins: DVDD and AVDD.

DVDD is the power supply pins used for digital block. AVDD is the power supply pins used for analog block.

It is recommended to design PCB with separate analog power supply and digital power supply without common impedance.

Moreover, it is recommended to have a countermeasure against noise and ripple at power supply. The bypass capacitor between power supply and ground is essential. A careful study of decoupling capacitor and the line filter on actual PCB. (Please refer to the application circuit diagram example for recommended values).

Regarding power supply start-up sequence, it is essential to apply power to DVDD first and then to AVDD or to apply simultaneously power to DVDD and AVDD. If the power is applied to AVDD before DVDD, the initialization may not be guaranteed.

When the power has been supplied, the SND signal must be set like following timing.

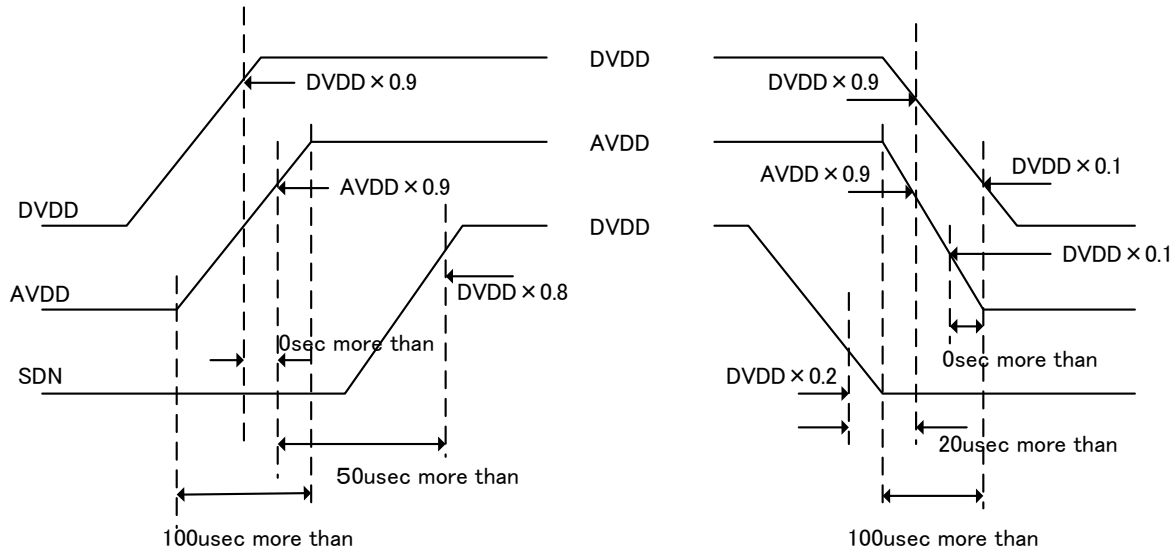

100us supply voltage in more than a start-up, please stand up. During the internal reset circuit is the initialization of the IC.

For start-up power supply

DVDD, AVDD confirmed the timing of these signals at the launch, please SDN.

For standing down power

After standing down signal SDN, at the timing of the above DVDD, AVDD started to please lower.

●About IC placement

IC will be placed in the environment, humidity and temperature changes locally as a dynamic place for Please avoid easy. Condensation sensors to the terminal, the sensor accuracy may be malfunctioning.

●PCB layout

The electrostatic sensor IC, PCB parasitic on the capacity to be vulnerable to the effects of, IC package itself also due to parasitic capacity and can not be ignored completely. In order to minimize the impact on small QFN package is adopted. In addition, the package parasite-induced changes in capacity to hold it back a bit to rand adopted a package.

The effect is difficult to present quantitative, the back of the rand dropped to the PCB in order to GND is recommended.

●Operating Sequence

The following figure illustrated the operating sequence. There are two modes able to use. When use the power management mode, the Host side can monitor INT signal to stop an operation of register read/write.

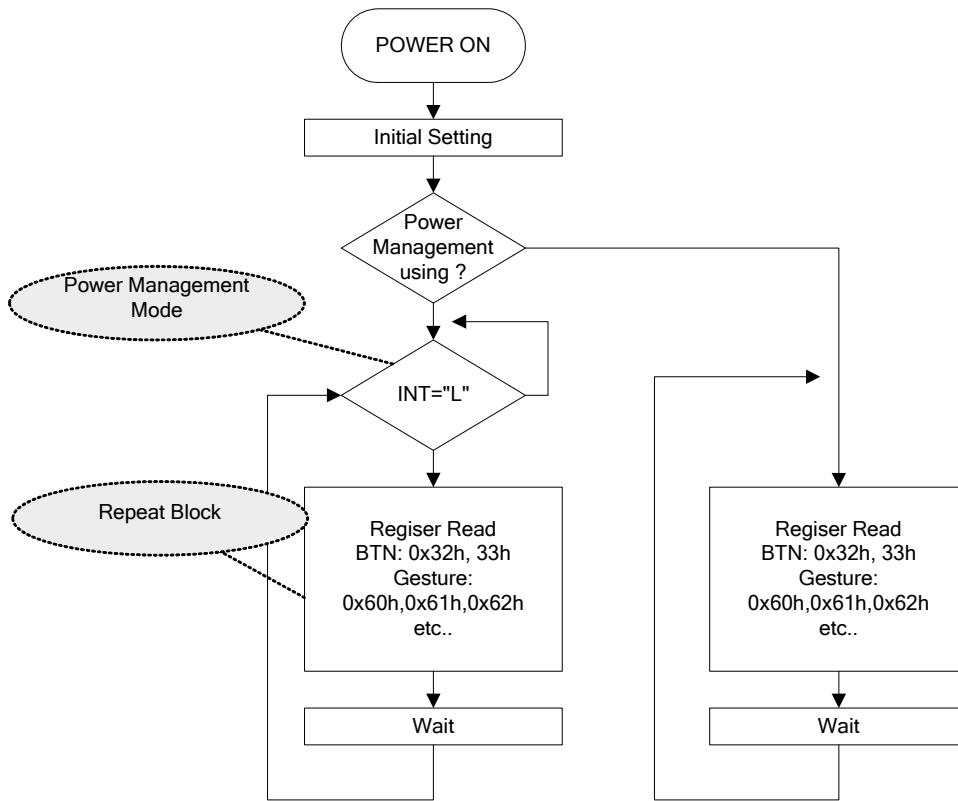

Operating sequence flow chart

●Initial Setting

The following figure illustrated an initial setting. According as the following flow to set. At the end of setting, to write configuration done "H" and then the detection will start to sense.

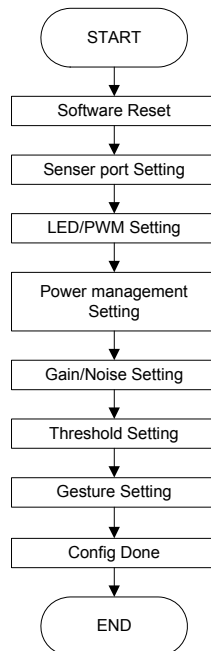

Initial setting flow chart

●Sensor Port Setting

To write register F0/F1 can enable/disable the Sensor Port. (H: enable, L: disable)

There is calibration (*) function on alternate ports of BU21008MUV. So the calibration port and no calibration port need pair to use. For example, SIN0 of the BU21008MUV can execute calibration, SIN1 can not and need to use a result of the SIN0 executed calibration. So disable the SIN0 and enable the SIN1 that is can't permit. But opposite way is can permit.

The ports are able to execute calibration and the other ports that pair of the calibration ports.

Port	Calibration	
SIN0	○	
SIN1	×	use a result of the SIN0 executed calibration
SIN2	○	
SIN3	×	use a result of the SIN2 executed calibration
SIN4	○	
SIN5	×	use a result of the SIN4 executed calibration
SIN6	○	
SIN7	×	use a result of the SIN6 executed calibration
SIN8	○	
SIN9	×	use a result of the SIN8 executed calibration
SIN10	○	
SIN11	×	use a result of the SIN10 executed calibration
SIN12	○	
SIN13	×	use a result of the SIN12 executed calibration
SIN14	○	
SIN15	×	use a result of the SIN14 executed calibration

○ : The port calibration
 × : Not calibration port

Each pair of ports needs to make the same size of electrode and the same length of wiring

Example)SIN0-7, SIN8,SIN10,SIN12,SIN14 を ON, SIN9,SIN11,SIN13,SIN15 を OFF

```
//LED port Setting
Write ( F0h, FFh )
Write ( F1h, 55h )
```

●LED/PWM Setting

- Function description

Enables LED LINK function, LEDs will turn ON/OFF when the sensor is sensing inputs or not.

PWM function can control LEDs brightness with ratio of pulse width. And the function can add Fade in/Fade out impression when LEDs turned ON/OFF.

	BU21008MUV
LED PORT	8
LED LINK	○
PWM (Fade in/Fade out)	○

- LED Setting flow

Even the LED ports are enabled when the sensor ports were enabled, the LED function will be unavailable.

If using LED function, the sensor ports need to be disabled.

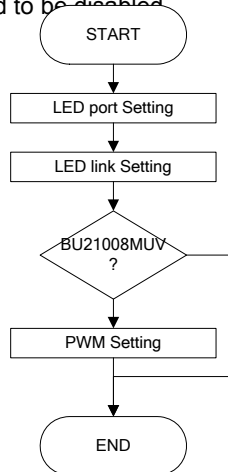

LED/PWM setting flow chart

Example) In case of the BU21008MUV, odd ports for LED controlling and even ports for sensing.
 SIN1,SIN3,SIN5,SIN7 add the Fade in/Fade out impression when LEDs turned ON/OFF.

```
//LED port Setting
Write ( F0h, 55h )
Write ( F2h, 55h )
```

```
//PWM
Write ( E0h, 1Fh )
Write ( E1h, 02h )
```

●Power Management Setting

- Power management state transition. There are five states "normal", "idle", "calibration", "configuration" and "initial calibration".
- Idle : In this state, the sampling cycle will be 1/8 and power consumption can be decreased.
- Normal : Normal operating state.
- Calibration : In this state, controller detects the capacitance difference between reference capacitor (SREF) and sensor (SIN*) to execute the offset correction automatically
- Configuration :In this state, the initial setting does not be executed.
- Initial calibration :The function of the state is the same with the Calibration but different form state transition.

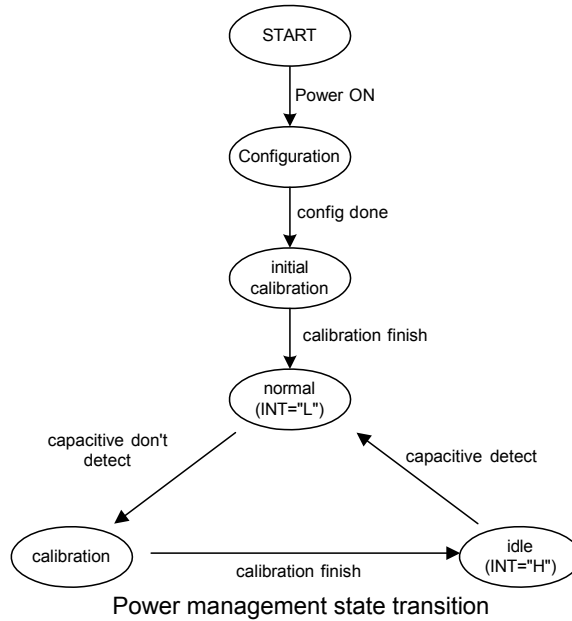

- Power management flow chart as shown. With monitoring the INT pin can know the sensor that is detecting capacitance or not. When the sensor did not detect any capacitance, the HOST side is not necessary to read register. So the HOST side can stop accessing. In the "idle" state, the INT pin was "L" . So it also can detect the state when it return to "normal".

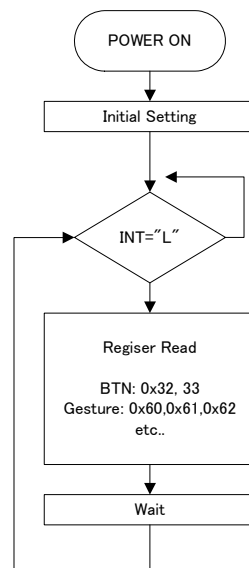

Power management flow chart

- It can know the state of the controller with the INT pin.
 - “L” : Normal operating state. The controller is normal to sense.
 - “H” : “idle” state.

A condition of INT pin when the “normal” state translate to the “idle” state, as shown in Fig. When the Sensor does not sense any capacitance, it will be the “idle” state with passing of BxN[sec] and the INT pin will be “H”.

	content	BU21008MUV
A	Sampling cycle	system clock x 2 ¹³
B	Time for idle	system clock x 2 ¹⁹
N	Setting Value of FAh Register	

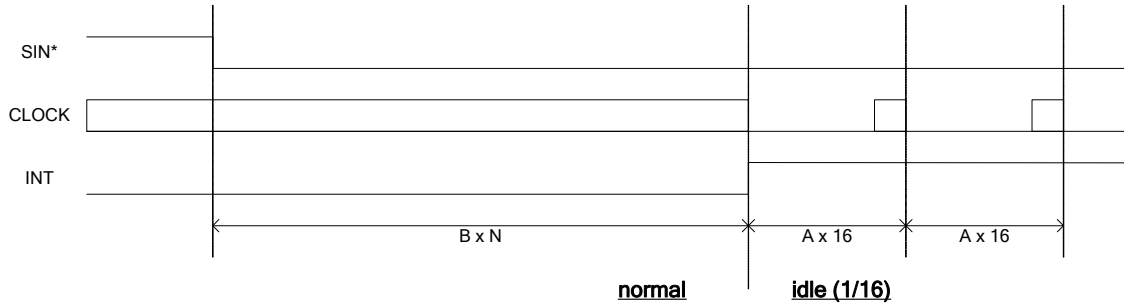

INT pin condition 1 (normal → idle)

A condition of INT pin when the “idle” state translate to the “normal” state, as shown in Fig. When the Sensor sense the capacitance, it will be the “normal” state with passing of Ax16x2[sec] . (1MHz : about 262msec)

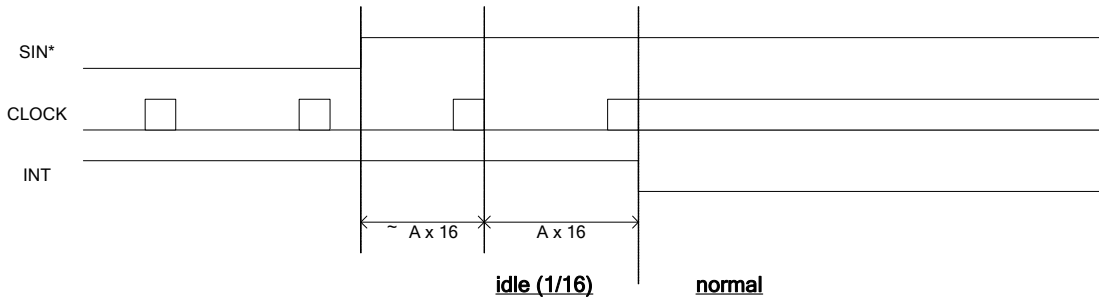

INT pin condition 2 (idle → normal)

Example) The power save mode will not translate to the normal mode even the SIN8-15 are being touched. For the final touch with passing of 8 sec, It will translate to the power save mode.

```
//Power management Setting
Write ( F3h, FFh )
Write ( F4h, 00h )

Write ( FAh, 1Fh )
```

●Gain/Noise Setting

- Gain
 - The Gain can adjust to x1~ x92.

GAIN[2:0]	000	001	010	011	100	101	110	111
Adjustment value	x 1	x 4.22	x 8.4	x 16.5	x 23	x 46	x 69	x 92

Example) GAIN x8.4, disable Filter

```
//Gain Setting
Write ( FBh, 40h )
```

- Noise
 - For a countermeasure against noise, there are two kinds of the functions that are Noise Filter and Chattering Canceller. The Noise Filter can limit the fluctuation (Δ) of the ADC output. It can cause noise to decrease. The Chattering Canceller is a digital filter that can detect a sequence of sensing ON states to decrease noise. Analog value and XY processing of the BU21009MUV are only applied to the Noise Filter.

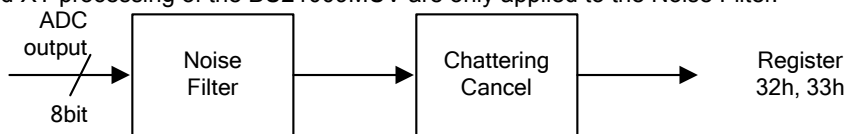

the circuit of noise

The Noise Filter limits the fluctuation (Δ) of the ADC output to decrease noise. For example, the ADC output is like ① of the Fig to set the fluctuation of every sampling cycle Δ . Then the following will be worsened like ② of the Fig. So it can decrease noise.

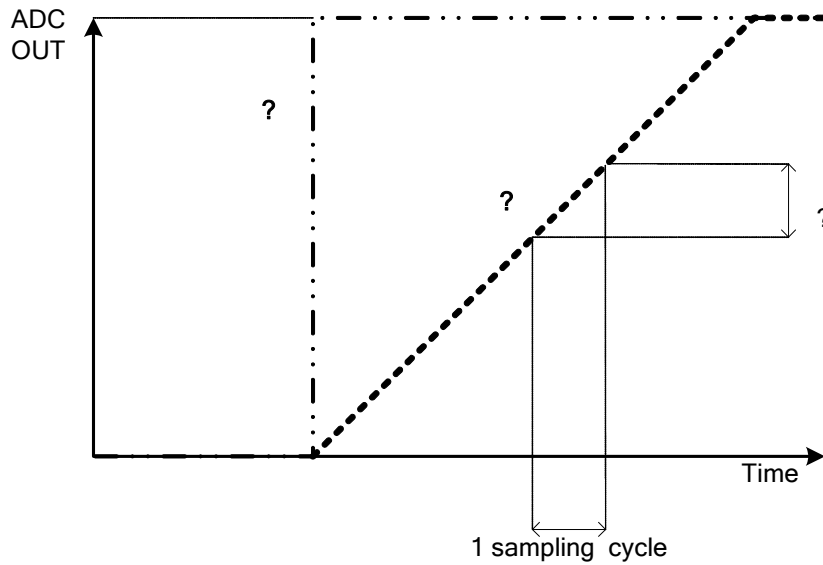

Noise Filter

The Chattering Canceller sampling setting.

Setting Value	0h	1h	2h	3h	4h	5h	6h	7h	8h	9h	Ah	Bh	Ch	Dh	Eh	Fh
Cancel Freq*1 [Hz]	-	61.0	30.5	20.3	15.3	12.2	10.2	8.7	7.6	6.8	6.1	5.5	5.1	4.7	4.4	4.1

*1) If the internal frequency of 1MHz

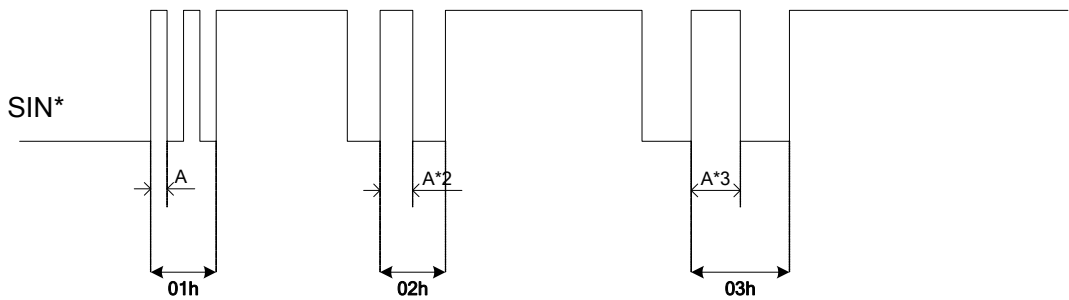

Chattering Canceller

Example) Set the Noise Filter Δ 2 and the Chattering Cancel sampling 3//Noise Filter

```
Write ( FBh, 12h )
// Chattering Cancel
Write ( F6h, 03h )
```

●Gesture

The Gesture Function is used with combination of 4 sensor ports. That can detect direction, duration and speed when a finger is pressing. This function only can be used by BU21008MUV. Only the 4 sensor ports that are SIN0, SIN2, SIN4 and SIN6 have the Gesture Function to use. And they can not change to the other sensor ports.

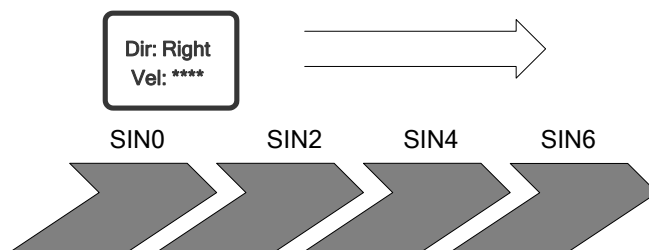

Gesture Image

For example detects the direction of the Gesture Function, as shown in Fig. At first read register of GES_DIR(62h). Next if a value of register GES_DIR is 01h or 02h, that is meaning the direction has been detected out. The value of the register GES_DIR will be kept until register GES_CLR(E2h) is written 80h to clear.

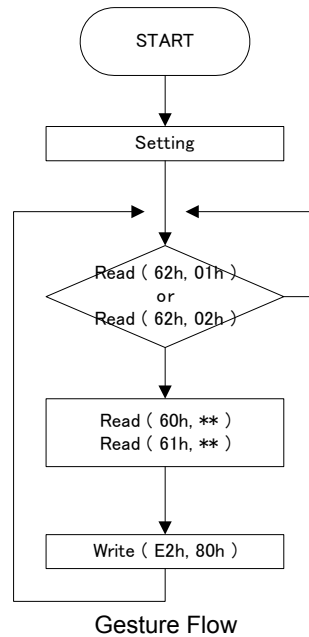

There are two modes that are the All detection mode and the Verbose mode to detect the gesture.
 All detection mode: Requires all sensors to be present in the sequence before the gesture is recognized.
 Verbose mode: Allows one or more of the keys to be missed in the sequence.

Mode	Value	Direction (GES_DIR)	Detected
All detection	0	DIR_A	1)SIN0→SIN2→SIN4→SIN6
		DIR_B	1)SIN6→SIN4→SIN2→SIN0
Verbose	1	DIR_A	1)SIN0→SIN2→SIN4
			2)SIN0→SIN2→ SIN6
		3) SIN2→SIN4→SIN6	
		4)SIN0→ SIN4	
DIR_B	5) SIN2→ SIN6		
	1)SIN6→SIN4→SIN2		
2)SIN6→SIN4→ SIN0			
3) SIN4→SIN2→SIN0			
4)SIN6→ SIN2			
5) SIN4→ SIN0			

Example) Set the value of the Gesture Mode 1 and Gesture maximum judgment time 1.9 sec.

```

//Gesture
Write ( E3h, 1Fh )
Write ( E4h, 00h )
Write ( E5h, FFh )
  
```

●Config Done

The register DONE (EFh) should be written 01h when all register have set up. And the controller will start to work. If any setting have to be changed when the controller is working, the register DONE (EFh) should be written 00h. After setting up write it 01h again.

```

//Config done
Write ( EFh, 01h )
  
```

●Setting examples

```

Write ( EDh, 01h ) //Software Reset
Write ( F0h, FFh ) //Sensor Port Setting
Write ( F1h, FFh ) //Sensor Port Setting
Write ( F6h, 20h ) // Chattering Cancel 2
Write ( FBh, 71h ) //GAIN*16 Noise FilterΔ1
Write ( FCh, 30h ) //OFF -> ON Threshold
Write ( FDh, 03h ) //ON -> OFF Threshold
Write ( EFh, 01h ) //Done
  
```

●Ordering part number

B	U
---	---

2	1	0	0	8
---	---	---	---	---

M	U	V
---	---	---

-	E	2
---	---	---

Part No

Part No

Package

MUV : VQFN032V5050

Packaging and forming specification

E2 : Embossed tape and reel

VQFN032V5050

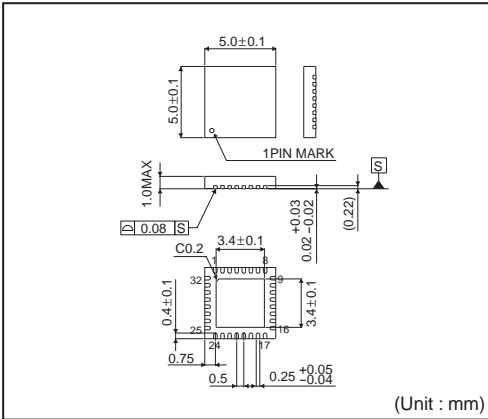

<Tape and Reel information>

Tape	Embossed carrier tape
Quantity	2500pcs
Direction of feed	E2 (The direction is the 1pin of product is at the upper left when you hold reel on the left hand and you pull out the tape on the right hand)

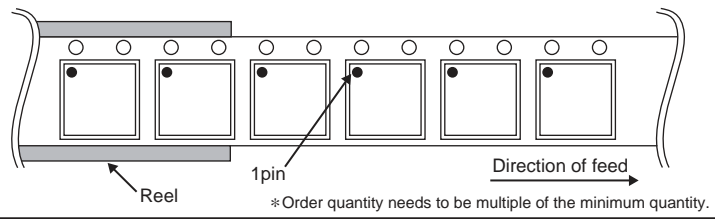

Notes

No copying or reproduction of this document, in part or in whole, is permitted without the consent of ROHM Co.,Ltd.

The content specified herein is subject to change for improvement without notice.

The content specified herein is for the purpose of introducing ROHM's products (hereinafter "Products"). If you wish to use any such Product, please be sure to refer to the specifications, which can be obtained from ROHM upon request.

Examples of application circuits, circuit constants and any other information contained herein illustrate the standard usage and operations of the Products. The peripheral conditions must be taken into account when designing circuits for mass production.

Great care was taken in ensuring the accuracy of the information specified in this document. However, should you incur any damage arising from any inaccuracy or misprint of such information, ROHM shall bear no responsibility for such damage.

The technical information specified herein is intended only to show the typical functions of and examples of application circuits for the Products. ROHM does not grant you, explicitly or implicitly, any license to use or exercise intellectual property or other rights held by ROHM and other parties. ROHM shall bear no responsibility whatsoever for any dispute arising from the use of such technical information.

The Products specified in this document are intended to be used with general-use electronic equipment or devices (such as audio visual equipment, office-automation equipment, communication devices, electronic appliances and amusement devices).

The Products specified in this document are not designed to be radiation tolerant.

While ROHM always makes efforts to enhance the quality and reliability of its Products, a Product may fail or malfunction for a variety of reasons.

Please be sure to implement in your equipment using the Products safety measures to guard against the possibility of physical injury, fire or any other damage caused in the event of the failure of any Product, such as derating, redundancy, fire control and fail-safe designs. ROHM shall bear no responsibility whatsoever for your use of any Product outside of the prescribed scope or not in accordance with the instruction manual.

The Products are not designed or manufactured to be used with any equipment, device or system which requires an extremely high level of reliability the failure or malfunction of which may result in a direct threat to human life or create a risk of human injury (such as a medical instrument, transportation equipment, aerospace machinery, nuclear-reactor controller, fuel-controller or other safety device). ROHM shall bear no responsibility in any way for use of any of the Products for the above special purposes. If a Product is intended to be used for any such special purpose, please contact a ROHM sales representative before purchasing.

If you intend to export or ship overseas any Product or technology specified herein that may be controlled under the Foreign Exchange and the Foreign Trade Law, you will be required to obtain a license or permit under the Law.



Thank you for your accessing to ROHM product informations.
More detail product informations and catalogs are available, please contact us.

ROHM Customer Support System

<http://www.rohm.com/contact/>