



SPECIFICATIONS

- ① Housing Material: PBT (UL94V-0), Green
- ② Lever Material : Polyamide 66 (UL94V-0), White
- ③ Terminals: Tin Plated Brass

Wire Range: 18~22 AWG

Rated: 11 Amperes.AC250V

Operation Temperature: -55°C~+100°C

Insulation withstands volt: AC2000V min

Insulation resistance: >1000MΩ or more at DC500V

Part Number:

HA-522-P

Pole Size 02~24P

Tolerance ± 0.50

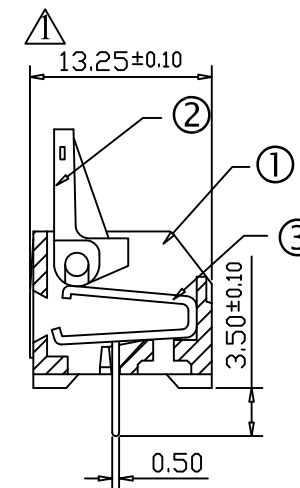
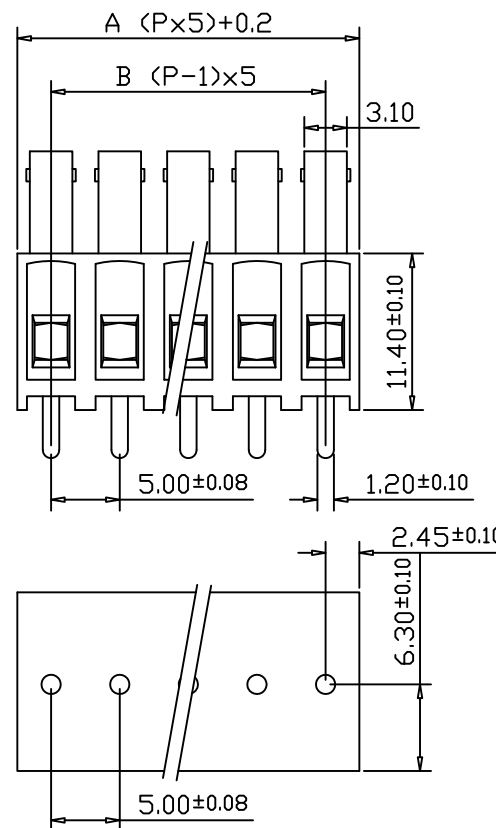

POLE	02	03	04	05	06	07	08	09	10	11	12	
A	10.2	15.2	20.2	25.2	30.2	35.2	40.2	45.2	50.2	55.2	60.2	
B	5	10	15	20	25	30	35	40	45	50	55	
POLE	13	14	15	16	17	18	19	20	21	22	23	24
A	65.2	70.2	75.2	80.2	85.2	90.2	95.2	100.2	105.2	110.2	115.2	120.2
B	60	65	70	75	80	85	90	95	100	105	110	115

文件發行
2018.01.31
黃琦婷



CO/Name	HOW DER ELECTRONIC CO.,LTD	REV.	CONTENT	DATE	NO.	PART NO.	DRAWING	DATE	DRAWING NO
P/Name	Barrier type terminal block	△	尺寸修改13.0修正13.25	2018 0131	①				HA-525002
					②		APPROVED	DATE	SCALE 2:1()
					③				SHEET 1/1
					④		CHECK	DATE	UNIT MM

http://www.howder-tw.com Tel:02-2223-1026

E-mail:howder.tb@msa.hinet.net Fax:02-2221-6471