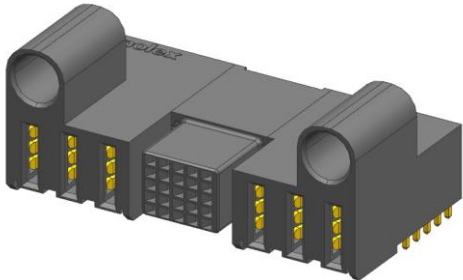
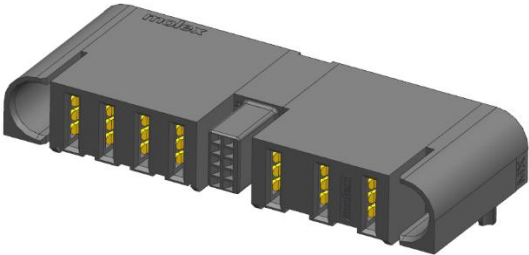
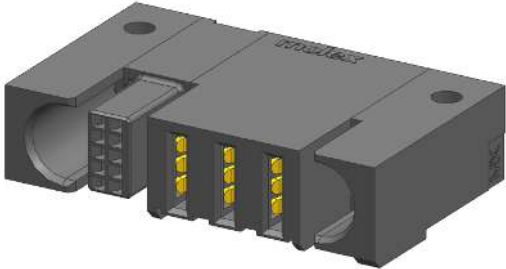
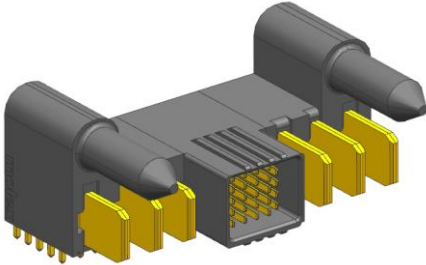

EXTREME TEN60POWER™

Board-To-Board CONNECTOR SYSTEM

<p>RA Receptacle Assembly with Top Guide</p>	<p>RA Receptacle Assembly with Side Guide</p>
	
<p>Series: 46436</p>	<p>Series: 46436</p>
<p>RA Receptacle Assembly with Screw down Guide</p>	<p>RA Plug Assembly with Top Guide</p>
	
<p>Series: 46436</p>	<p>Series: 46437</p>

[Extreme Ten60Power Connectors Web Page](#)

[TABLE OF CONTENTS](#)

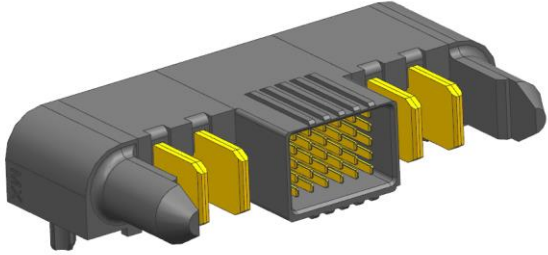
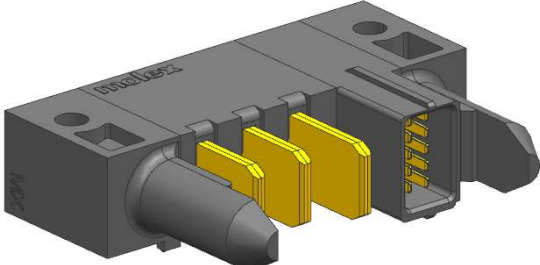

<p>REVISION: E8</p>	<p>ECM INFORMATION: EC No: 754843 DATE: 2023/07/10</p>	<p>TITLE: PRODUCT SPECIFICATION FOR TEN60 POWER BOARD TO BOARD INTERCONNECT SYSTEMS</p>				<p>SHEET No. 1 of 29</p>
<p>DOCUMENT NUMBER: PS-46436-100</p>	<p>DOC TYPE: PS</p>	<p>DOC PART: 001</p>	<p>CREATED / REVISED BY: ABHIRK</p>	<p>CHECKED BY: SUVARS</p>	<p>APPROVED BY: HTHYAGARAJ</p>	
<p>TEMPLATE FILENAME: 1703070003 REV A</p>						

RA Plug Assembly with Side Guide	RA Plug Assembly with Screw down Guide
	
Series: 46437	Series: 46437

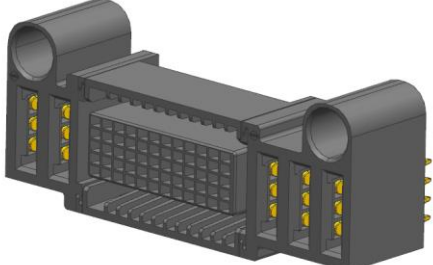
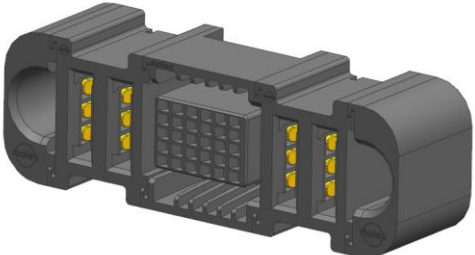
Vertical Receptacle Assembly with Top Guide	Vertical Receptacle Assembly with Side Guide
	
Series: 46562	Series: 46562

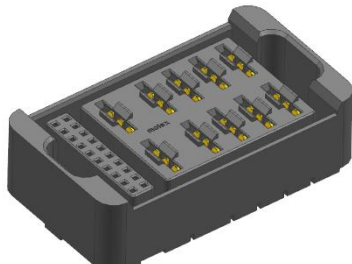
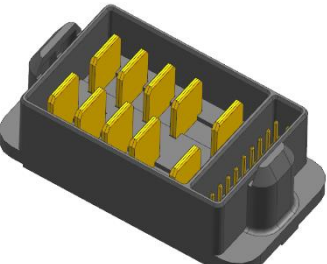
Vertical Receptacle Assembly	Vertical Plug Assembly
	
Series: 76541	Series: 76546

[Extreme Ten60Power Connectors Web Page](#)

[TABLE OF CONTENTS](#)



REVISION: E8	ECM INFORMATION: EC No: 754843 DATE: 2023/07/10	TITLE: PRODUCT SPECIFICATION FOR TEN60 POWER BOARD TO BOARD INTERCONNECT SYSTEMS				SHEET No. 2 of 29
DOCUMENT NUMBER: PS-46436-100	DOC TYPE: PS	DOC PART: 001	CREATED / REVISED BY: ABHIRK	CHECKED BY: SUVARS	APPROVED BY: HTHYAGARAJ	
TEMPLATE FILENAME: 1703070003 REV A						



RA Power Plug Modules (1-10 ckt)



RA Power Receptacle Modules (1-10 ckt)



Vertical Power Receptacle Modules (1-10 ckt)

Note: All power modules are available at 5.5 mm pitch for DC (low voltage) applications and 7.5 mm pitch AC (high voltage) application. See pg. 16 for recommended PCB lay-outs.

[Extreme Ten60Power Connectors Web Page](#)

[TABLE OF CONTENTS](#)



REVISION: E8	ECM INFORMATION: EC No: 754843 DATE: 2023/07/10	TITLE: PRODUCT SPECIFICATION FOR TEN60 POWER BOARD TO BOARD INTERCONNECT SYSTEMS				SHEET No. 3 of 29
DOCUMENT NUMBER: PS-46436-100	DOC TYPE: PS	DOC PART: 001	CREATED / REVISED BY: ABHIRK	CHECKED BY: SUVARS	APPROVED BY: HTHYAGARAJ	
TEMPLATE FILENAME: 1703070003 REV A						



RA Signal Plug Modules (6-36 ckt) or RA HDS Plug Module (10-60 ckt)



RA Signal Receptacle Modules (6-36 ckt) or RA HDS Receptacle Module (10-40 ckt)



Vertical Signal Recept. Modules (6-36 ckt) or Vertical HDS Recept. Module (10-60 ckt)

[Extreme Ten60Power Connectors Web Page](#)

[TABLE OF CONTENTS](#)



REVISION: E8	ECM INFORMATION: EC No: 754843 DATE: 2023/07/10	TITLE: PRODUCT SPECIFICATION FOR TEN60 POWER BOARD TO BOARD INTERCONNECT SYSTEMS				SHEET No. 4 of 29
DOCUMENT NUMBER: PS-46436-100	DOC TYPE: PS	DOC PART: 001	CREATED / REVISED BY: ABHIRK	CHECKED BY: SUVARS	APPROVED BY: HTHYAGARAJ	
TEMPLATE FILENAME: 1703070003 REV A						

Table of Contents

<u>ITEMS</u>	<u>PAGE</u>
1.0 SCOPE	6
2.0 PRODUCT DESCRIPTION	6
2.1 PRODUCT NAME AND SERIES NUMBER (S)	6
2.2 DIMENSIONS, MATERIALS, PLATINGS	6
2.3 ENVIRONMENTAL CONFORMANCE	6
2.4 SAFETY AGENCY LISTINGS	7
3.0 APPLICABLE DOCUMENTS AND SPECIFICATION	8
3.1 MOLEX DOCUMENTS	8
3.2 INDUSTRY DOCUMENTS	8
4.0 ELECTRICAL PERFORMANCE RATINGS	8
4.1 VOLTAGE	8
4.2 CURRENT RATING (MAXIMUM AMPERES)	9
4.3 TEMPERATURE	12
4.4 DURABILITY	12
5.0 QUALIFICATION	12
6.0 PERFORMANCE	13
6.1 ELECTRICAL PERFORMANCE	13
6.2 MECHANICAL PERFORMANCE	14
6.3 ENVIRONMENTAL PERFORMANCE	16
7.0 PRINTED CIRCUIT BOARD SPECIFICATION	17
7.1 PCB THROUGH HOLE SPEC	17
7.2 TYPICAL PCB PADS LAY-OUT AND SIGNAL HOLES LAY-OUT	18
7.3 WIPE LENGTH DETAILS	20
7.4 TYPICAL MATING SEQUENCE: POWER & 3 ROW SIGNAL	23
7.5 TYPICAL MATING SEQUENCE: POWER & 5 ROW SIGNAL	24
8.0 TEST SEQUENCE GROUPS	26
9.0 SOLDER INFORMATION	28
9.1 SOLDER PROCESS TEMPERATURES	28
9.2 SOLDERING PROFILE	28
10.0 PACKAGING	29

[Extreme Ten60Power Connectors Web Page](#)

[TABLE OF CONTENTS](#)



REVISION: E8	ECM INFORMATION: EC No: 754843 DATE: 2023/07/10	TITLE: PRODUCT SPECIFICATION FOR TEN60 POWER BOARD TO BOARD INTERCONNECT SYSTEMS	SHEET No. 5 of 29
DOCUMENT NUMBER: PS-46436-100	DOC TYPE: PS	DOC PART: 001	CREATED / REVISED BY: ABHIRK
	CHECKED BY: SUVARS	APPROVED BY: HTHYAGARAJ	
TEMPLATE FILENAME: 1703070003 REV A			

1.0 SCOPE

The specification covers the performance requirements and test methods of Ten60Power and signal modular board to board interconnect systems.

2.0 PRODUCT DESCRIPTION

2.1 PRODUCT NAME AND SERIES NUMBER (S)

This specification covers following board to board configuration
Right Angle (RA) Plug assembly mated to RA Receptacle assembly (Coplanar configuration)

46436-XXXX	RA Receptacle Side Assembly
46437-XXXX	RA Plug Side Assembly

Right Angle (RA) Plug assembly mated to Vertical Receptacle assembly (Backplane configuration)

46562-XXXX	Vertical Receptacle Side Assembly
46437-XXXX	RA Plug Side Assembly

Vertical Plug Assy mated to Vertical Receptacle Assy (Mezzanine configuration)

76541-XXXX	Vertical Receptacle Side Assembly
76546-XXXX	Vertical Plug Side Assembly

2.2 DIMENSIONS, MATERIALS, PLATINGS

Dimensions: See individual sales drawings.
Plating: Gold on mating surfaces and tin on PC tail with nickel under-plating overall.

2.3 ENVIRONMENTAL CONFORMANCE

To find product compliance information:

- [Go to molex.com](http://molex.com)
- Enter the part number in the search field.
- At the bottom of the page go to "Environmental" to see compliance status.

[Extreme Ten60Power Connectors Web Page](#)

[TABLE OF CONTENTS](#)



REVISION: E8	ECM INFORMATION: EC No: 754843 DATE: 2023/07/10	TITLE: PRODUCT SPECIFICATION FOR TEN60 POWER BOARD TO BOARD INTERCONNECT SYSTEMS	SHEET No. 6 of 29
DOCUMENT NUMBER: PS-46436-100	DOC TYPE: PS	DOC PART: 001	CREATED / REVISED BY: ABHIRK
		CHECKED BY: SUVARS	APPROVED BY: HTHYAGARAJ
TEMPLATE FILENAME: 1703070003 REV A			

2.4 SAFETY AGENCY LISTINGS

2.4.1  **File Number*: LR-19980_A_000 Class 6233-81**

CSA approval meets following standards/test procedures:

- a) CSA std. C22.2 No. 182.3-M1987
- b) UL-1977

* - "C" and "US" mark adjacent to CSA signifies that the product has been evaluated to the applicable CSA and ANSI/UL standards, for use in Canada and US respectively.

CSA NON-current interruption	CSA Current interruption
2.5 Amps @ 250V for Legacy Signal ckt 4.5 Amps @ 75V for HDS Signal ckt 60 Amps @ 600V for power ckt	2.5 Amp at 28V for Legacy Signal ckt 4.5 Amps @ 28V for HDS Signal ckt 50 Amps at 60V for power ckt

2.4.2 **UL – IEC61984 EU- Certificate Number: UL-EU-01060-A1**



UL-CB - Report – E29179 -D1-CB
IEC 61984-1
Non-current interruption
7.5 mm Pitch 600 volts AC/DC @60 amps
5.5 mm Pitch 250 volts DC @ 60 amps
Signal
Signal Legacy (3 row) 120 Volts AC/DC @ 60 amps
Signal HDS (5 row) 120 Volts AC/DC @ 1.0 amps
IEC 61984 Certification: Tested to and found in compliance with IEC 61984. Certificate available from Molex upon request. Contact Molex safety agency team for questions regarding certification on specific part numbers.

2.4.3 **UL File Number: E29179**

UL NON-current interruption
2.5 Amps @ 250V for Legacy signal ckt 4.5 Amps @ 120V for HDS signal ckt 80 Amps @ 600V for power ckt

[Extreme Ten60Power Connectors Web Page](#)

[TABLE OF CONTENTS](#)



REVISION: E8	ECM INFORMATION: EC No: 754843 DATE: 2023/07/10	TITLE: PRODUCT SPECIFICATION FOR TEN60 POWER BOARD TO BOARD INTERCONNECT SYSTEMS	SHEET No. 7 of 29
DOCUMENT NUMBER: PS-46436-100	DOC TYPE: PS	DOC PART: 001	CREATED / REVISED BY: ABHIRK
		CHECKED BY: SUVARS	APPROVED BY: HTHYAGARAJ

3.0 APPLICABLE DOCUMENTS AND SPECIFICATION

3.1 MOLEX DOCUMENTS

- [Extreme Ten60Power Connector System Application summary AS-4636-100-001](#)
- [Molex Solderability Specification SMES-152](#)
- [Molex Heat Resistance Specification AS-40000-5013](#)
- [Molex Moisture Technical Advisory AS-45499-001](#)
- [Molex Package Handling Specification 454990100-PK](#)
- ATS – Application Tooling Specification*

*Application Tooling Specification for terminals is not provided in this document. ATS for terminals can be available from respective terminal part number page in Molex.com

3.2 INDUSTRY DOCUMENTS

- EIA-364-1000
- UL-60950-1
- CSA STD. C22.2 NO. 182.3-M1987
- IEC 61984
- UL-1977

4.0 ELECTRICAL PERFORMANCE RATINGS

4.1 VOLTAGE

- Legacy Signal Module: 250 Volts
- HDS Signal Module: 120 Volts
- Power Module: 250 or 600 Volts (Ref. to pads layout in section 7.2)

Connector Rating per UL-1977

Connector voltage rating meets the connector approval level defined by UL 1977, Sect. 11 for spacing per table 11.1. Example: 1.2 mm for ≤ 250 volt; 3.2 mm for ≥ 250 volt.

Exception taken for spacing less than those specified are permitted, if the device complies with the requirements in the dielectric voltage withstanding test per Sect. 17

Application Voltage Guideline

For application voltage requirements please refer to UL-60950 or other applicable standards, the creepage & clearance also needs to be determined based upon pads/traces on the PCB.

[Extreme Ten60Power Connectors Web Page](#)

[TABLE OF CONTENTS](#)



REVISION: E8	ECM INFORMATION: EC No: 754843 DATE: 2023/07/10	TITLE: PRODUCT SPECIFICATION FOR TEN60 POWER BOARD TO BOARD INTERCONNECT SYSTEMS	SHEET No. 8 of 29
DOCUMENT NUMBER: PS-46436-100	DOC TYPE: PS	DOC PART: 001	CREATED / REVISED BY: ABHIRK
		CHECKED BY: SUVARS	APPROVED BY: HTHYAGARAJ
TEMPLATE FILENAME: 1703070003 REV A			

4.2 CURRENT RATING (MAXIMUM AMPERES)

Signal Contact: 2.5 Amps
 HDS Signal Contact: 4.5 Amps
 Power Contact:

1. Tested with PCB Copper Planes: See charts on page 10.

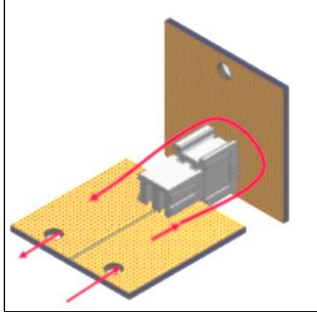

No. of Power Circuits	1-Ckt	2-Ckt	4-Ckt	8-Ckt
Current (Amps)	94Amps	85Amps	76Amps	65Amps

** Tested in accordance with EIA-364-70. Refer section 6.1.5

The above current ratings are based on testing connectors are mounted to a 10-Layer PCB with 2Oz per layer copper planes. Rating shown represents maximum current carrying capacity at 30°C temperature rise over ambient temperature.

2. Tested with Copper Coupons: See charts on page 11.

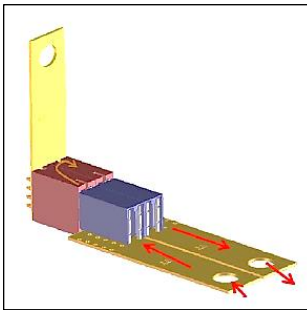

No. of Power Contacts	1-Ckt	2-Ckt	4-Ckt	8-Ckt
Current (Amps)	62Amps	59Amps	57Amps	53Amps

**Tested in accordance with EIA-364-70. Refer section 6.1.5

The above current ratings are based on testing connectors are mounted on a copper coupon. Rating shown represents maximum current carrying capacity at 30°C temperature rise over ambient temperature.

“Current rating is application dependent and should be used as a guideline. Appropriate rating is required per ckt size, ambient conditions, copper trace size on the PCB, gross heating from adjacent modules/components and other factors that influence connector performance”

[Extreme Ten60Power Connectors Web Page](#)

[TABLE OF CONTENTS](#)



REVISION: E8	ECM INFORMATION: EC No: 754843 DATE: 2023/07/10	TITLE: PRODUCT SPECIFICATION FOR TEN60 POWER BOARD TO BOARD INTERCONNECT SYSTEMS	SHEET No. 9 of 29
DOCUMENT NUMBER: PS-46436-100	DOC TYPE: PS	DOC PART: 001	CREATED / REVISED BY: ABHIRK
		CHECKED BY: SUVARS	APPROVED BY: HTHYAGARAJ
TEMPLATE FILENAME: 1703070003 REV A			

TESTED WITH COPPER PLANES (10 Layers, 20z per each Layer)

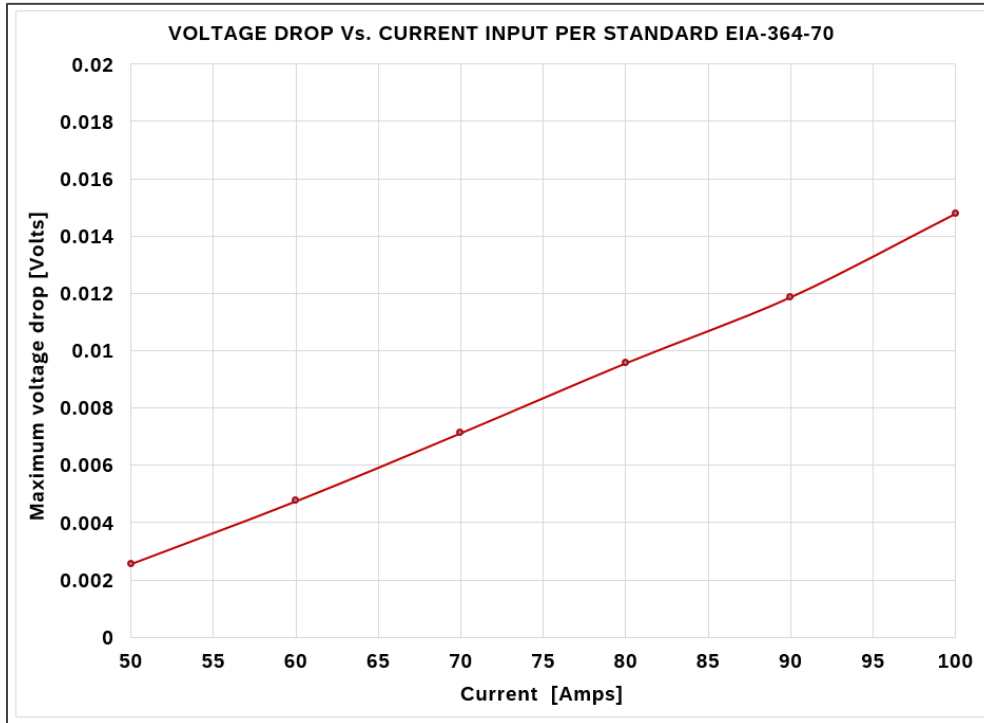
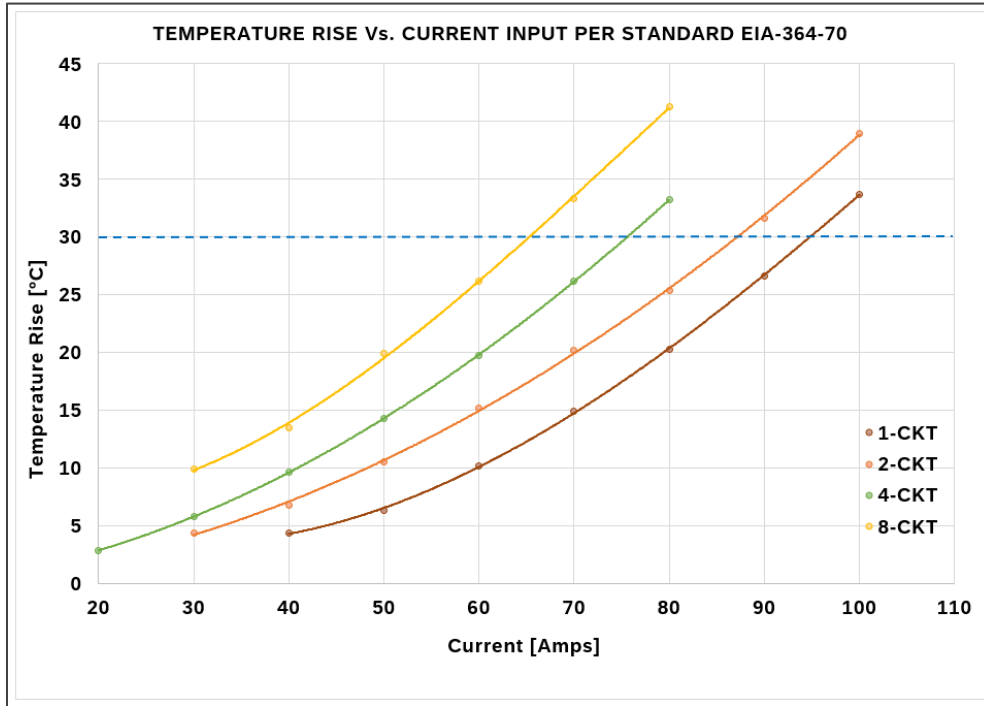

[Extreme Ten60Power Connectors Web Page](#)

[TABLE OF CONTENTS](#)



REVISION: E8	ECM INFORMATION: EC No: 754843 DATE: 2023/07/10	TITLE: PRODUCT SPECIFICATION FOR TEN60 POWER BOARD TO BOARD INTERCONNECT SYSTEMS	SHEET No. 10 of 29
DOCUMENT NUMBER: PS-46436-100	DOC TYPE: PS	DOC PART: 001	CREATED / REVISED BY: ABHIRK
		CHECKED BY: SUVARS	APPROVED BY: HTHYAGARAJ
TEMPLATE FILENAME: 1703070003 REV A			

TESTED WITH COPPER COUPONS

TEMPERATURE RISE Vs. CURRENT INPUT PER STANDARD EIA-364-70

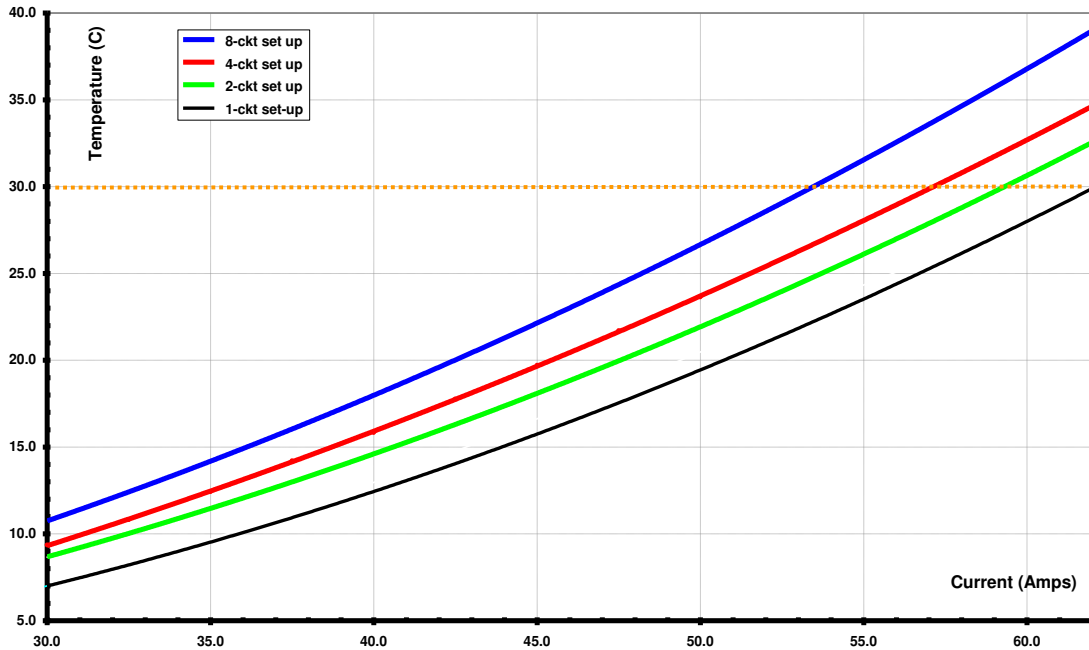

VOLTAGE DROP (MAX.) Vs. CURRENT INPUT PER STANDARD EIA-364-70

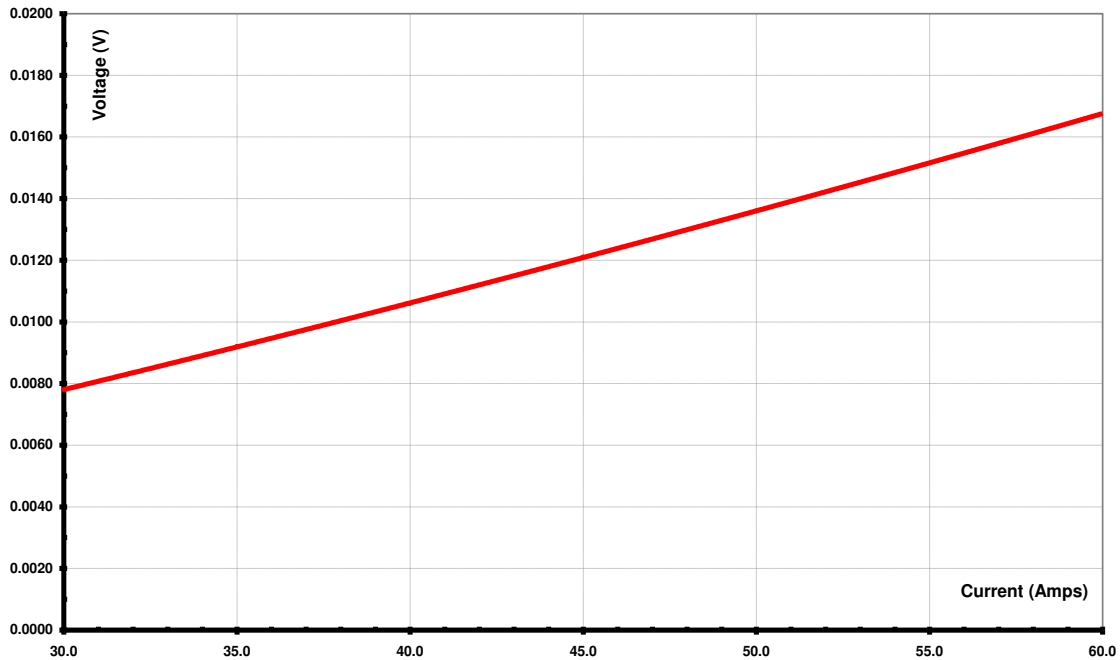

[Extreme Ten60Power Connectors Web Page](#)

[TABLE OF CONTENTS](#)



REVISION: E8	ECM INFORMATION: EC No: 754843 DATE: 2023/07/10	TITLE: PRODUCT SPECIFICATION FOR TEN60 POWER BOARD TO BOARD INTERCONNECT SYSTEMS	SHEET No. 11 of 29
DOCUMENT NUMBER: PS-46436-100	DOC TYPE: PS	DOC PART: 001	CREATED / REVISED BY: ABHIRK
		CHECKED BY: SUVARS	APPROVED BY: HTHYAGARAJ
TEMPLATE FILENAME: 1703070003 REV A			

4.3 TEMPERATURE

Operating temperature (including T-rise from applied current) is -40° C to +105° C.

Temperature life tested per EIA 364-17 Method A for 240 hrs@105° per table 8 to meet field temperature of 65° C for 10 years life. See page 22 for detail test sequence of EIA-364-1000, Group I.

4.4 DURABILITY

Plating Type	Number of Cycles
Gold Plated	200

As tested in accordance with EIA-364-1000 test method C section 7 (see sec 6.2.3 of this specification). Durability per EIA-364-09

5.0 QUALIFICATION

Laboratory condition, sample selection and test sequences are in accordance with EIA-364-1000.

[Extreme Ten60Power Connectors Web Page](#)

[TABLE OF CONTENTS](#)



REVISION: E8	ECM INFORMATION: EC No: 754843 DATE: 2023/07/10	TITLE: PRODUCT SPECIFICATION FOR TEN60 POWER BOARD TO BOARD INTERCONNECT SYSTEMS				SHEET No. 12 of 29
DOCUMENT NUMBER: PS-46436-100	DOC TYPE: PS	DOC PART: 001	CREATED / REVISED BY: ABHIRK	CHECKED BY: SUVARS	APPROVED BY: HTHYAGARAJ	
TEMPLATE FILENAME: 1703070003 REV A						

6.0 PERFORMANCE

6.1 ELECTRICAL PERFORMANCE

ITEM	DESCRIPTION	TEST CONDITION	REQUIREMENT
6.1.1	Initial Contact Resistance (Low Level)	Per EIA-364-23	Signal Contact: 30 mΩ Power Contact: 0.3 mΩ
6.1.2	Voltage Drop (@ Rated Current)	Mate connectors; apply the rated current. Per EIA-364-70	Typical Voltage Drop: Power Contact: see chart, Page 10 & 11
6.1.3	Insulation Resistance	Apply 500 VDC between adjacent terminals or ground. Per EIA-364-21	5,000 MΩ minimum
6.1.4	Dielectric Withstanding Voltage	Apply 1500 VDC for 1 minute between adjacent terminals or ground. Per EIA-364-20	No breakdown
6.1.5	Temperature Rise	Mate connectors Measure T-Rise @ Rated Current After 96 Hours. Per EIA-364-70	30°C T-Rise

[Extreme Ten60Power Connectors Web Page](#)

[TABLE OF CONTENTS](#)



REVISION: E8	ECM INFORMATION: EC No: 754843 DATE: 2023/07/10	TITLE: PRODUCT SPECIFICATION FOR TEN60 POWER BOARD TO BOARD INTERCONNECT SYSTEMS	SHEET No. 13 of 29
DOCUMENT NUMBER: PS-46436-100	DOC TYPE: PS	DOC PART: 001	CREATED / REVISED BY: ABHIRK
		CHECKED BY: SUVARS	APPROVED BY: HTHYAGARAJ
TEMPLATE FILENAME: 1703070003 REV A			

6.2 MECHANICAL PERFORMANCE

ITEM	DESCRIPTION	TEST CONDITION	REQUIREMENT	
6.2.1	Mating Force, Single Circuit**	Mate connectors at a rate of 25.4±6 mm per minute Per EIA-364-37	Legacy Signal 75 g/ckt Max	
			Power Vert Recept to R/A Plug 756 g/ckt Max	Power R/A Recept to R/A Plug 443 g/ckt Max
			HDS* 55 g/ckt Max	
6.2.2	Unmating Force, Single Circuit**	Unmate connectors at a rate of 25.4±6 mm per minute Per EIA-364-37	Legacy Signal 23 g/ckt Min	
			Power Vert Recept to R/A Plug 316 g/ckt Min	Power R/A Recept to R/A Plug 253 g/ckt Min
			HDS* 25 g Min per Contact	
6.2.3	Durability w/o Environment	Mate connectors 20 cycles at a max rate of 10 cycles per minute Per EIA-364-09	Maximum Change: Signal Contact: 10 mΩ Power Contact: 0.30 mΩ	
6.2.4	Contact Retention	Axial pullout force on the terminal in the housing at a rate of 25.4±6 mm per minute Per EIA-364-29	R/A Power 1336 g Min	
			Vert Power 754 g Min	
			Vert HDS Signals 544 g Min per coupon	
			R/A HDS Signals 275 g Min per coupon	

* HDS: High Density Signal (5 Row Signal Design)

** Mate/Unmate Data is for 1st Cycle

[Extreme Ten60Power Connectors Web Page](#)

[TABLE OF CONTENTS](#)



REVISION: E8	ECM INFORMATION: EC No: 754843 DATE: 2023/07/10	TITLE: PRODUCT SPECIFICATION FOR TEN60 POWER BOARD TO BOARD INTERCONNECT SYSTEMS	SHEET No. 14 of 29
DOCUMENT NUMBER: PS-46436-100	DOC TYPE: PS	DOC PART: 001	CREATED / REVISED BY: ABHIRK
		CHECKED BY: SUVARS	APPROVED BY: HTHYAGARAJ
TEMPLATE FILENAME: 1703070003 REV A			

6.2 MECHANICAL PERFORMANCE CONTINUED

ITEM	DESCRIPTION	TEST CONDITION	REQUIREMENT
6.2.5	Min Extraction force for Terminals with Compliant Pins	Pull-out contacts at a rate of 25.4±6 mm per minute	MIN: 1.10 lbs. (0.5 Kg/pin) (Legacy Signal Module)
			MIN: 1.00 lbs. (0.45 Kg/pin) (HDS Module)
6.2.5			MIN: 2.37 lbs./pin (1.08 Kg/pin) Vertical Power Receptacle
			MIN: 2.4 lbs./pin (1.09 Kg/pin) R/A Power Plug
6.2.6	Vibration (EIA-364-1000)	Mate connectors and vibrate per EIA-364-28 test condition VII-D 15 minutes each axis.	Maximum Change: Signal Contact: 10 mΩ Power Contact: 0.50 mΩ
6.2.7	Mechanical Shock (EIA-364-1000)	Mate connectors and shock at 50 g with ½ sine wave (11 milliseconds) shocks in the 3 axes (18 shocks total) Per EIA-364-27	Maximum Change: Signal Contact: 10 mΩ Power Contact: 0.50 mΩ
6.2.8	Max Insertion force into PCB for Terminals with Compliant Pins	Insert contact at a rate of 25.4±6 mm per minute	MAX: 12.54 lbs/pin (5.7 Kg/ckt) (Legacy Signal Module)
			MAX: 10.02 lbs/pin (4.54 kg/ckt) (HDS module)
6.2.8			MAX: 18.5 lbs/pin (8.41 kg/pin) (Vertical Pwr Receptacle)
			MAX: 17.6 lbs/pin (7.98 kg/pin) (R/A Pwr Plug)

[Extreme Ten60Power Connectors Web Page](#)

[TABLE OF CONTENTS](#)



REVISION: E8	ECM INFORMATION: EC No: 754843 DATE: 2023/07/10	TITLE: PRODUCT SPECIFICATION FOR TEN60 POWER BOARD TO BOARD INTERCONNECT SYSTEMS	SHEET No. 15 of 29
DOCUMENT NUMBER: PS-46436-100	DOC TYPE: PS	DOC PART: 001	CREATED / REVISED BY: ABHIRK
		CHECKED BY: SUVARS	APPROVED BY: HTHYAGARAJ
TEMPLATE FILENAME: 1703070003 REV A			

6.3 ENVIRONMENTAL PERFORMANCE

ITEM	DESCRIPTION	TEST CONDITION	REQUIREMENT
6.3.1	Thermal Shock (EIA-364-1000)	Mate connectors, expose to 10 cycles from -55°C to 85°C Per EIA-364-32	Maximum Change: Signal Contact: 10 mΩ Power Contact: 0.50 mΩ
6.3.2	Temperature Life (EIA-364-1000)	Mate Connectors, expose to 240 hours at 105°C Per EIA-364-17	Maximum Change: Signal Contact: 10 mΩ Power Contact: 0.50 mΩ
6.3.3	Cyclic Temperature and Humidity (EIA-364-1000)	Mate connectors: expose to 24 cycles from 25 °C / 80% RH to 65 °C / 50% RH Per EIA-364-31	Maximum Change: Signal Contact: 10 mΩ Power Contact: 0.50 mΩ
6.3.4	Dust (EIA-364-1000)	Un-mated 1-hour duration 25°C/50% RH dust mass of 9 g/ft ³ at rate of 300 m/min. Per EIA-364-91	Maximum Change: Signal Contact: 10 mΩ Power Contact: 0.50 mΩ
6.3.5	Mixed Flowing Gas (EIA-364-1000)	168 hours un-mated, 168 hours mated, Per EIA-364-65 Class II-A	Maximum Change: Signal Contact: 10 mΩ Power Contact: 0.50 mΩ
6.3.6	Solderability Dip Test	Molex test method:	Solder area shell have Min of 95% solder coverage
6.3.7	Compliant pin retention force from PCB board after soldering process	Per EIA-364-61, Test procedure 4 for compliant pin retention force	22.5 lbs. (10.2 Kg) Per Power contact extraction force from PCB
6.3.8	Resistance to soldering heat from rework	Per EIA-364-61, Test procedure 2 (Test Condition II)	No dimensions change No physical damage

[Extreme Ten60Power Connectors Web Page](#)

[TABLE OF CONTENTS](#)



REVISION: E8	ECM INFORMATION: EC No: 754843 DATE: 2023/07/10	TITLE: PRODUCT SPECIFICATION FOR TEN60 POWER BOARD TO BOARD INTERCONNECT SYSTEMS	SHEET No. 16 of 29
DOCUMENT NUMBER: PS-46436-100	DOC TYPE: PS	DOC PART: 001	CREATED / REVISED BY: ABHIRK
		CHECKED BY: SUVARS	APPROVED BY: HTHYAGARAJ
TEMPLATE FILENAME: 1703070003 REV A			

7.0 PRINTED CIRCUIT BOARD SPECIFICATION

7.1 PCB THROUGH HOLE SPEC.

Profile for 1.02 mm (finish) holes:

TIN PLATED OR OSP HOLE DIMENSIONS IN MM/IN

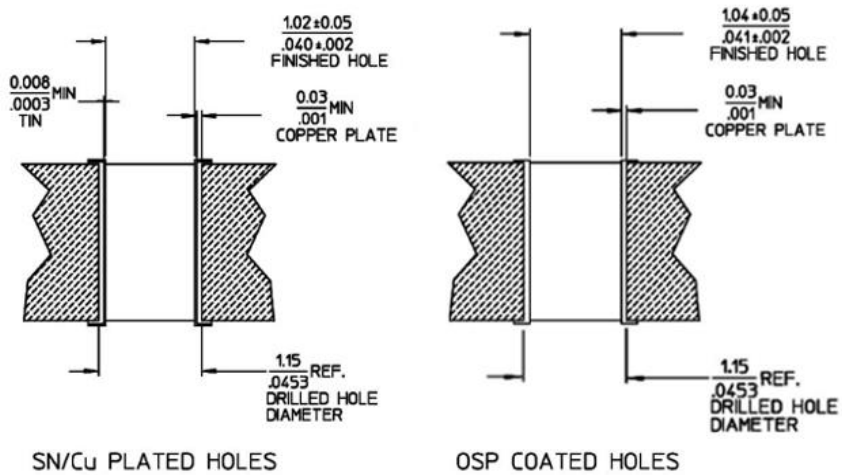

Profile for 0.70mm (finish) holes – Signal segment:

TIN PLATED OR OSP HOLE DIMENSIONS IN MM/IN

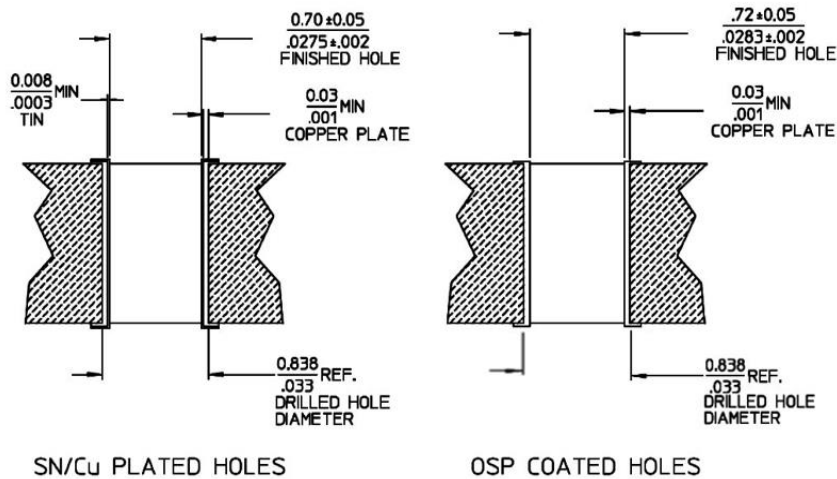

[Extreme Ten60Power Connectors Web Page](#)

[TABLE OF CONTENTS](#)



REVISION: E8	ECM INFORMATION: EC No: 754843 DATE: 2023/07/10	TITLE: PRODUCT SPECIFICATION FOR TEN60 POWER BOARD TO BOARD INTERCONNECT SYSTEMS				SHEET No. 17 of 29
DOCUMENT NUMBER: PS-46436-100	DOC TYPE: PS	DOC PART: 001	CREATED / REVISED BY: ABHIRK	CHECKED BY: SUVARS	APPROVED BY: HTHYAGARAJ	
TEMPLATE FILENAME: 1703070003 REV A						

Notes:

1. The finished hole size is the critical feature for proper performance of the compliant pin terminal. The reference drill sizes listed are recommended by Molex to achieve the finished PCB hole size.
2. Depending on the specific manufacturer's plating process a different drill size can be used to achieve the required finished PCB hole size.

7.2 TYPICAL PCB PADS LAY-OUT AND SIGNAL HOLES LAY-OUT

DIMENSIONS ARE MM/IN

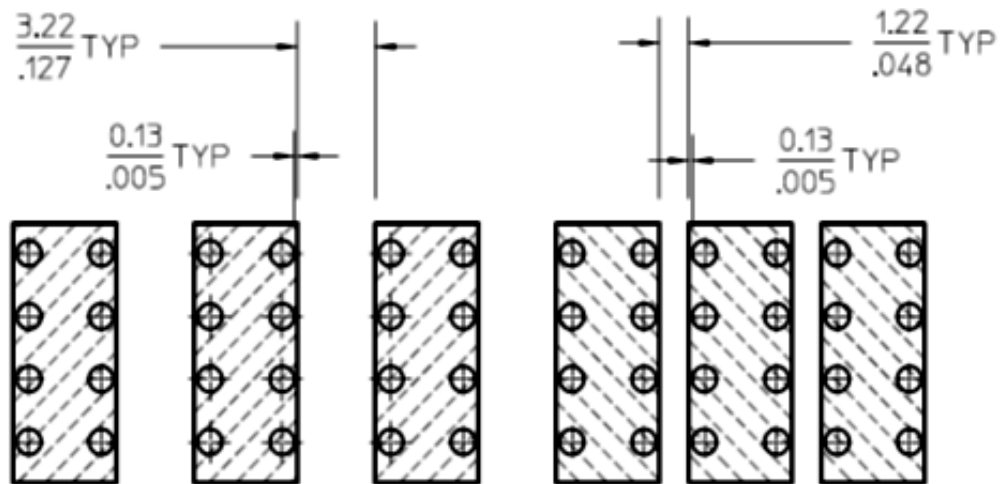

Pads lay-out for power modules with 7.5 mm pitch for high voltage

Pads lay-out for power modules with 5.5 mm pitch for low voltage

[Extreme Ten60Power Connectors Web Page](#)

[TABLE OF CONTENTS](#)



REVISION: E8	ECM INFORMATION: EC No: 754843 DATE: 2023/07/10	TITLE: PRODUCT SPECIFICATION FOR TEN60 POWER BOARD TO BOARD INTERCONNECT SYSTEMS				SHEET No. 18 of 29
DOCUMENT NUMBER: PS-46436-100	DOC TYPE: PS	DOC PART: 001	CREATED / REVISED BY: ABHIRK	CHECKED BY: SUVARS	APPROVED BY: HTHYAGARAJ	
TEMPLATE FILENAME: 1703070003 REV A						

Typical Hole Lay-out For 5 row Signal/ HDS modules (0.70mm dia holes)

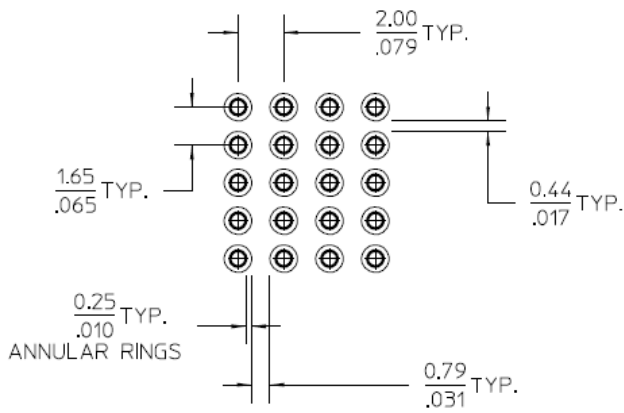

**PCB lay-out for HDS modules
Vertical conf. only**

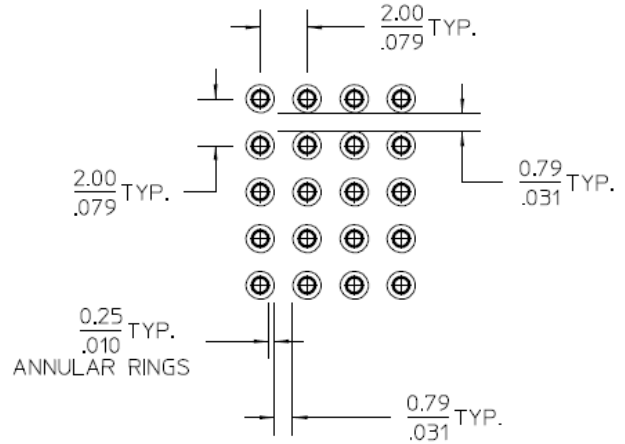

**PCB lay-out for HDS modules
R/A conf. only**

Typical Signal Hole Lay-out for 2.54mmX2.54mm Signal modules (1.02mm dia holes)

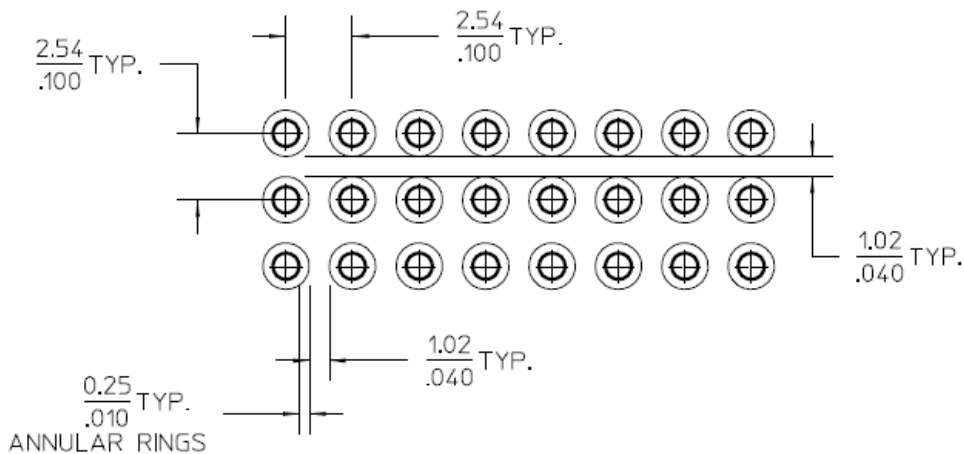

[Extreme Ten60Power Connectors Web Page](#)

[TABLE OF CONTENTS](#)



REVISION: E8	ECM INFORMATION: EC No: 754843 DATE: 2023/07/10	TITLE: PRODUCT SPECIFICATION FOR TEN60 POWER BOARD TO BOARD INTERCONNECT SYSTEMS	SHEET No. 19 of 29
DOCUMENT NUMBER: PS-46436-100	DOC TYPE: PS	DOC PART: 001	CREATED / REVISED BY: ABHIRK
		CHECKED BY: SUVARS	APPROVED BY: HTHYAGARAJ
TEMPLATE FILENAME: 1703070003 REV A			

7.3 WIPE LENGTH DETAILS

RIGHT ANGLE TO RIGHT ANGLE ORIENTATION			
	Length of blade	Nominal Wipe(mm)	Minimum Wipe (Statistical)(mm)*
Power Blades	Long Blade (12mm)	7.9	7.5
	Standard Blade (10mm)	5.9	5.5
	Short Blade (8mm)	3.9	3.5
HDS Signal Blades	Long Blade	4.3	3.9
	Standard Blade	3.3	2.9
	Short Blade	2.3	1.9
3-Row Signal	Long Blade	3.8	3.5
	Short Blade	2.5	2.2

[Extreme Ten60Power Connectors Web Page](#)

[TABLE OF CONTENTS](#)



REVISION: E8	ECM INFORMATION: EC No: 754843 DATE: 2023/07/10	TITLE: PRODUCT SPECIFICATION FOR TEN60 POWER BOARD TO BOARD INTERCONNECT SYSTEMS	SHEET No. 20 of 29
DOCUMENT NUMBER: PS-46436-100	DOC TYPE: PS	DOC PART: 001	CREATED / REVISED BY: ABHIRK
		CHECKED BY: SUVARS	APPROVED BY: HTHYAGARAJ
TEMPLATE FILENAME: 1703070003 REV A			

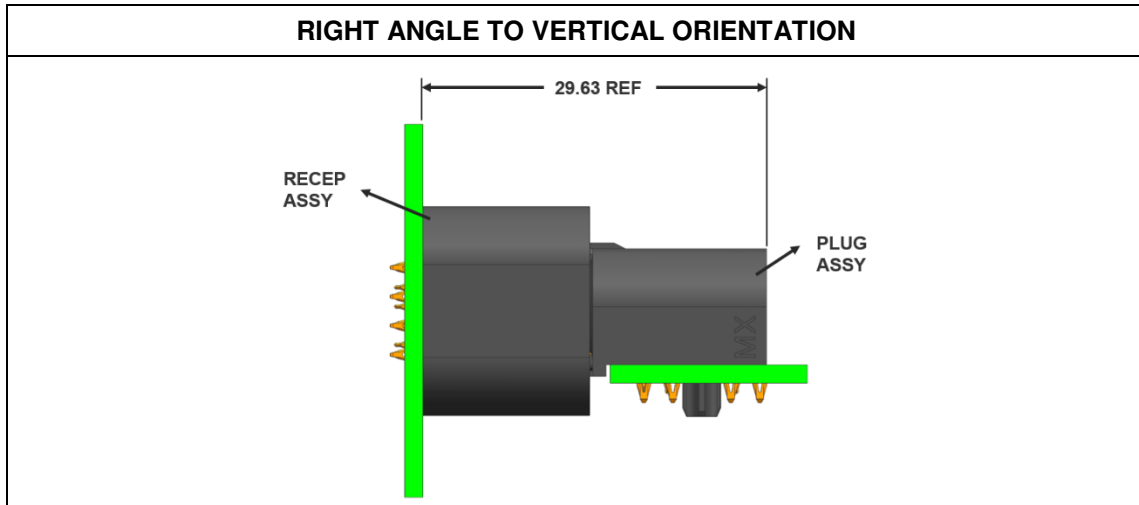

	Length of blade	Nominal Wipe(mm)	Minimum Wipe (Statistical)(mm)*
Power Blades	Long Blade (12mm)	6.8	6.4
	Standard Blade (10mm)	4.8	4.4
	Short Blade (8mm)	2.8	2.4
HDS Signal Blades	Long Blade	4.2	3.9
	Standard Blade	3.2	2.9
	Short Blade	2.2	1.9
3-Row Signal	Long Blade	3.7	3.4
	Short Blade	2.4	2.1

[Extreme Ten60Power Connectors Web Page](#)

[TABLE OF CONTENTS](#)



REVISION: E8	ECM INFORMATION: EC No: 754843 DATE: 2023/07/10	TITLE: PRODUCT SPECIFICATION FOR TEN60 POWER BOARD TO BOARD INTERCONNECT SYSTEMS				SHEET No. 21 of 29
DOCUMENT NUMBER: PS-46436-100	DOC TYPE: PS	DOC PART: 001	CREATED / REVISED BY: ABHIRK	CHECKED BY: SUVARS	APPROVED BY: HTHYAGARAJ	
TEMPLATE FILENAME: 1703070003 REV A						

VERTICAL TO VERTICAL (MEZZANINE CONFIGURATION)

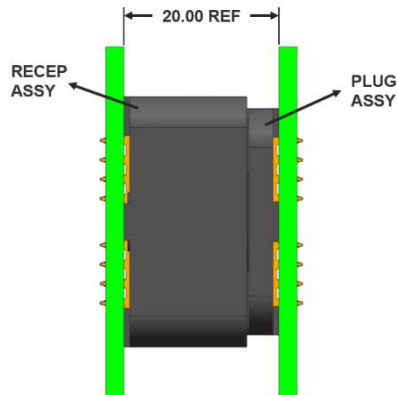

	Length of blade	Nominal Wipe(mm)	Minimum Wipe (Statistical)(mm)*
Power Blades	Long Blade (11.25mm)	6.8	6.4
	Short Blade (9.25mm)	4.8	4.4
Legacy Signal	Long Blade	3.8	3.4
	Short Blade	2.8	2.4

*Minimum wipe is determined using RSS tolerance analysis for the connector only assuming at mated condition as per reference mating length provided in the illustration above. Mated profile tolerances and system tolerances are not considered into the analysis

[Extreme Ten60Power Connectors Web Page](#)

[TABLE OF CONTENTS](#)



REVISION: E8	ECM INFORMATION: EC No: 754843 DATE: 2023/07/10	TITLE: PRODUCT SPECIFICATION FOR TEN60 POWER BOARD TO BOARD INTERCONNECT SYSTEMS	SHEET No. 22 of 29
DOCUMENT NUMBER: PS-46436-100	DOC TYPE: PS	DOC PART: 001	CREATED / REVISED BY: ABHIRK
		CHECKED BY: SUVARS	APPROVED BY: HTHYAGARAJ
TEMPLATE FILENAME: 1703070003 REV A			

7.4 TYPICAL MATING SEQUENCE: POWER & 3 ROW SIGNAL (RA-RA & RA-VERTICAL)

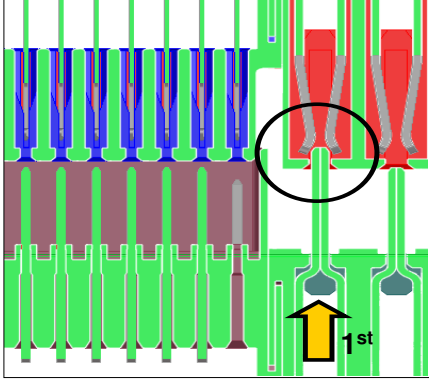
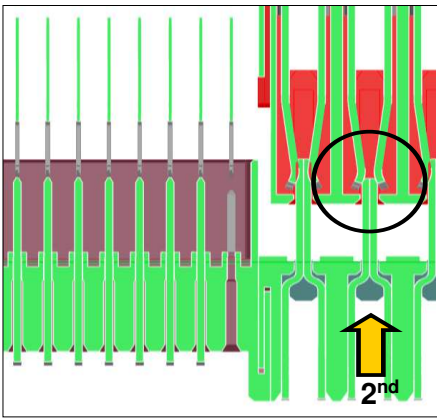
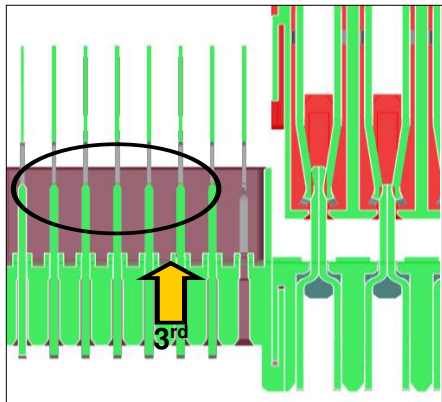
SEQUENCE NO.	SEQUENCE IMAGE	DESCRIPTION
1		<p>Long/Ground power blade(s) (typically used for FMLB) mates first.</p>
2		<p>Short power blade(s) mates second.</p>
3 & 4		<p>3. After short power blade(s) the long signal pins (typically the top row) mates third. 4. After long signal pins, the rest of other signal pins will mate.</p>

[Extreme Ten60Power Connectors Web Page](#)

[TABLE OF CONTENTS](#)



REVISION: E8	ECM INFORMATION: EC No: 754843 DATE: 2023/07/10	TITLE: PRODUCT SPECIFICATION FOR TEN60 POWER BOARD TO BOARD INTERCONNECT SYSTEMS				SHEET No. 23 of 29
DOCUMENT NUMBER: PS-46436-100		DOC TYPE: PS	DOC PART: 001	CREATED / REVISED BY: ABHIRK	CHECKED BY: SUVARS	APPROVED BY: HTHYAGARAJ
TEMPLATE FILENAME: 1703070003 REV A						

7.5 TYPICAL MATING SEQUENCE: POWER & 5 ROW SIGNAL (RA-RA & RA-VERTICAL)

SEQUENCE NO.	SEQUENCE IMAGE	DESCRIPTION
1		<p>Long/Ground power blade(s) (typically used for FMLB) mates first.</p>
2		<p>Standard power blade(s) mates second.</p>
3		<p>Long/Ground signal blade(s) (FMLB) mates third.</p>

[Extreme Ten60Power Connectors Web Page](#)

[TABLE OF CONTENTS](#)



REVISION: E8	ECM INFORMATION: EC No: 754843 DATE: 2023/07/10	TITLE: PRODUCT SPECIFICATION FOR TEN60 POWER BOARD TO BOARD INTERCONNECT SYSTEMS				SHEET No. 24 of 29
DOCUMENT NUMBER: PS-46436-100		DOC TYPE: PS	DOC PART: 001	CREATED / REVISED BY: ABHIRK	CHECKED BY: SUVARS	APPROVED BY: HTHYAGARAJ
TEMPLATE FILENAME: 1703070003 REV A						

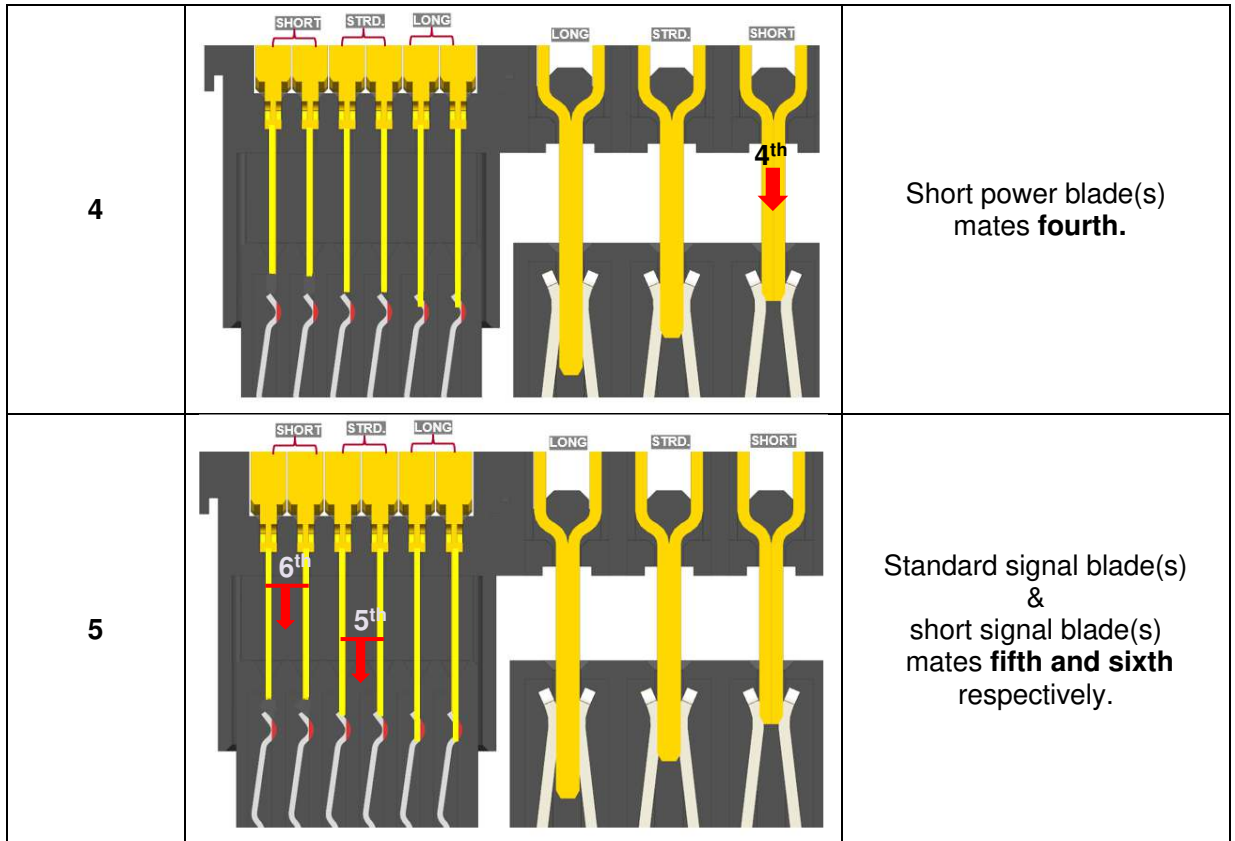

(Shown mating sequence in 7.4 & 7.5 is typical, custom configurations available on request)

(Note – Power: Long Blades-12mm, Standard Blades-10mm & Short Blades-8mm.

(Extended length on the mating side).

5 Pin Signal: Long Blades-0.91mm, Standard Blades-1.92mm & short Blades-2.92mm.

(Measured from tip of signal module housing to tip of the blade as per sales drawing).

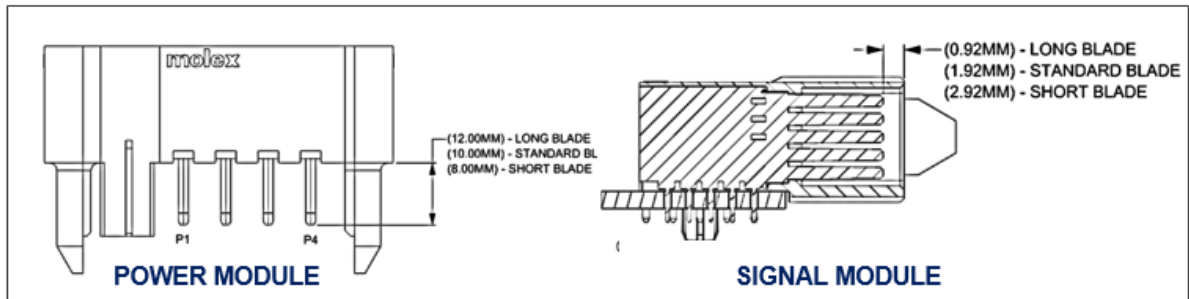

[Extreme Ten60Power Connectors Web Page](#)

[TABLE OF CONTENTS](#)



REVISION: E8	ECM INFORMATION: EC No: 754843 DATE: 2023/07/10	TITLE: PRODUCT SPECIFICATION FOR TEN60 POWER BOARD TO BOARD INTERCONNECT SYSTEMS	SHEET No. 25 of 29
DOCUMENT NUMBER: PS-46436-100	DOC TYPE: PS	DOC PART: 001	CREATED / REVISED BY: ABHIRK
		CHECKED BY: SUVARS	APPROVED BY: HTHYAGARAJ
TEMPLATE FILENAME: 1703070003 REV A			

8.0 TEST SEQUENCE GROUPS

Reliability Test Sequences per EIA-364-1000

Group I	Group II	Group III	Group IV	Group V	Group VI
Initial Contact Resistance EIA-364-23	Initial Contact Resistance EIA-364-23	Initial Contact Resistance EIA-364-23	Initial Contact Resistance EIA-364-23	Initial Contact Resistance EIA-364-23	Initial Contact Resistance EIA-364-23
Durability 20 cycles EIA-364-09	Durability 20 cycles EIA-364-09	Durability 20 cycles EIA-364-09	Durability 20 cycles EIA-364-09	Durability 20 cycles EIA-364-09	Durability 20 cycles EIA-364-09
Contact Resistance	Contact Resistance	Contact Resistance	Contact Resistance	Contact Resistance	Contact Resistance
Temperature Life 105°C, 240 hours 10 Yrs @ 65°C EIA-364-17	Thermal Shock 10 cycles -55°C and +85°C EIA-364-32	Temperature Life Preconditioning 10 Yrs @ 65°C EIA-364-17	Temperature Life Preconditioning 10 Yrs @ 65°C EIA-364-17	Temperature Life Preconditioning 10 Yrs @ 65°C EIA-364-17	Dust EIA-364-91 Benign Composition
Contact Resistance	Contact Resistance	Contact Resistance	Contact Resistance	Contact Resistance	Thermal Disturbance EIA-364-1000
Reseating 3 cycles EIA-364-1000	Cyclic Temperature and Humidity EIA-364-31	Random Vibration EIA-364-28 Condition VIID	Flowing Mixed Gas 7 days unmated EIA-364-65	Thermal Cycling EIA-364-1000	Contact Resistance
Contact Resistance	Contact Resistance	Contact Resistance	Contact Resistance	Contact Resistance	Reseating 3 cycles EIA-364-1000
	Reseating 3 cycles EIA-364-1000		Flowing Mixed Gas 7 days mated EIA-364-65	Reseating 3 cycles EIA-364-1000	Contact Resistance
	Contact Resistance		Contact Resistance	Contact Resistance	
			Thermal Disturbance EIA-364-1000		
			Contact Resistance		
			Reseating 3 cycles EIA-364-1000		
			Contact Resistance		

[Extreme Ten60Power Connectors Web Page](#)

[TABLE OF CONTENTS](#)



REVISION: E8	ECM INFORMATION: EC No: 754843 DATE: 2023/07/10	TITLE: PRODUCT SPECIFICATION FOR TEN60 POWER BOARD TO BOARD INTERCONNECT SYSTEMS				SHEET No. 26 of 29
DOCUMENT NUMBER: PS-46436-100	DOC TYPE: PS	DOC PART: 001	CREATED / REVISED BY: ABHIRK	CHECKED BY: SUVARS	APPROVED BY: HTHYAGARAJ	
TEMPLATE FILENAME: 1703070003 REV A						

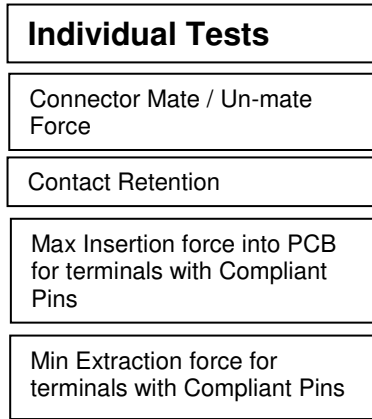
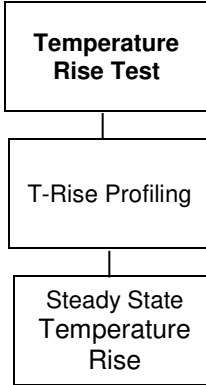
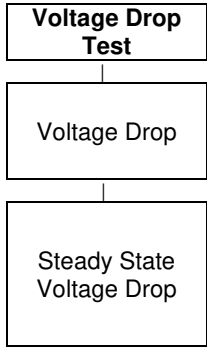

[Extreme Ten60Power Connectors Web Page](#)

[TABLE OF CONTENTS](#)



REVISION: E8	ECM INFORMATION: EC No: 754843 DATE: 2023/07/10	TITLE: PRODUCT SPECIFICATION FOR TEN60 POWER BOARD TO BOARD INTERCONNECT SYSTEMS	SHEET No. 27 of 29
DOCUMENT NUMBER: PS-46436-100	DOC TYPE: PS	DOC PART: 001	CREATED / REVISED BY: ABHIRK
		CHECKED BY: SUVARS	APPROVED BY: HTHYAGARAJ
TEMPLATE FILENAME: 1703070003 REV A			

9.0 SOLDER INFORMATION

Per SMES-152 and AS-40000-5013

*These specifications establish standard solderability test methods used to evaluate a products ability to accept molten solder. Solder Process Temperatures and Reflow Solder Profiles will vary based on application, equipment, solder paste, PCB thickness, etc.

9.1 SOLDER PROCESS TEMPERATURES *

Reflow Solder Temperature: 260°C Maximum

[Molex Solderability Specification SMES-152 \(Click Here\)](#)

9.2 SOLDERING PROFILE

(This profile is per JEDEC J-STD-020D.1 and it is for guideline only; please see notes for additional information)

[Molex Connector Heat Resistance Specification AS-40000-5013 \(Click Here\)](#)

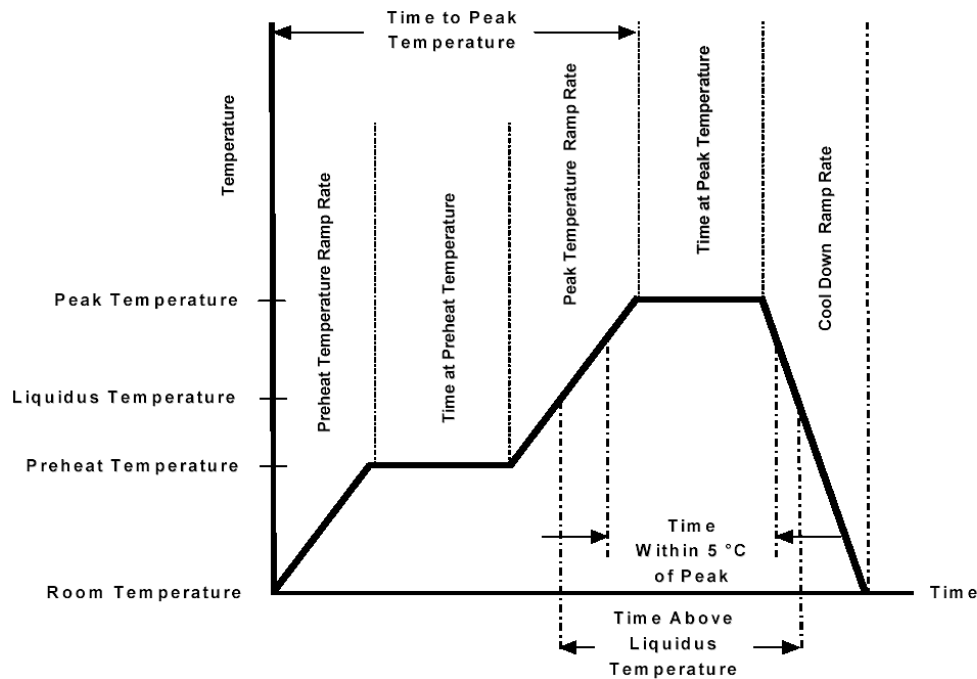

[Extreme Ten60Power Connectors Web Page](#)

[TABLE OF CONTENTS](#)



REVISION: E8	ECM INFORMATION: EC No: 754843 DATE: 2023/07/10	TITLE: PRODUCT SPECIFICATION FOR TEN60 POWER BOARD TO BOARD INTERCONNECT SYSTEMS				SHEET No. 28 of 29
DOCUMENT NUMBER: PS-46436-100	DOC TYPE: PS	DOC PART: 001	CREATED / REVISED BY: ABHIRK	CHECKED BY: SUVARS	APPROVED BY: HTHYAGARAJ	
TEMPLATE FILENAME: 1703070003 REV A						

Description	Requirement
Average Ramp Rate	3°C/sec Max
Preheat Temperature	150°C Min to 200°C Max
Preheat Time	60 to 180 sec
Ramp to Peak	3°C/sec Max
Time over Liquids (217°C)	60 to 150 sec
Peak Temperature	260 +0/-5°C
Time within 5°C of Peak	20 to 40 sec
Ramp - Cool Down	6°C/sec Max
Time 25°C to Peak	8 min Max

Notes:

1. Temperature indicated refers to the PCB surface temperature at solder tail area.
2. Connector can withstand up to 3 reflow cycles with a cool-down to room temperature in-between.
3. Actual reflow profile also depends on equipment, solder paste, PCB thickness, and other components on the board. Please consult your solder paste & reflow equipment manufacturer for their recommendations to adopt a suitable process.

10.0 PACKAGING

Parts shall be packaging to protect the parts from damage during standard shipping, storage, and handling. Refer Molex.com specific part number webpage to get the exact packaging document for that item.

[Extreme Ten60Power Connectors Web Page](#)

[TABLE OF CONTENTS](#)



REVISION: E8	ECM INFORMATION: EC No: 754843 DATE: 2023/07/10	TITLE: PRODUCT SPECIFICATION FOR TEN60 POWER BOARD TO BOARD INTERCONNECT SYSTEMS	SHEET No. 29 of 29
DOCUMENT NUMBER: PS-46436-100	DOC TYPE: PS	DOC PART: 001	CREATED / REVISED BY: ABHIRK
		CHECKED BY: SUVARS	APPROVED BY: HTHYAGARAJ
TEMPLATE FILENAME: 1703070003 REV A			