

REVISIONS					
P	LTR	DESCRIPTION	DATE	DWN	APVD
B1		ECR-16-017266	01JUN2018	SR	PO

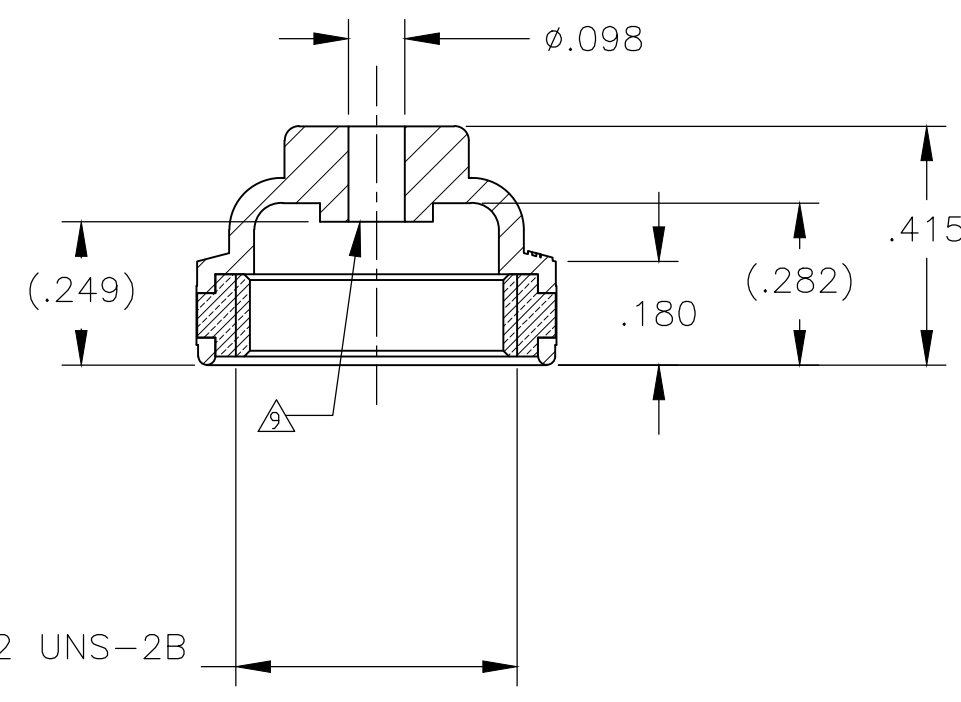
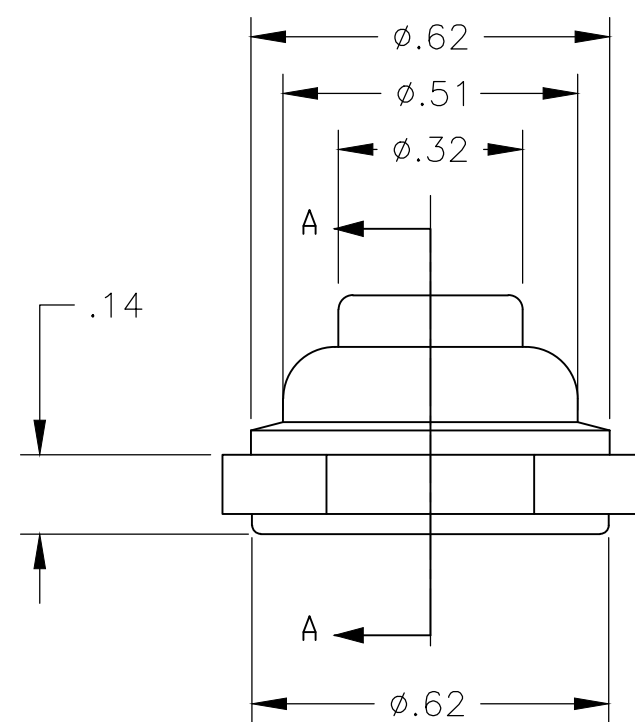
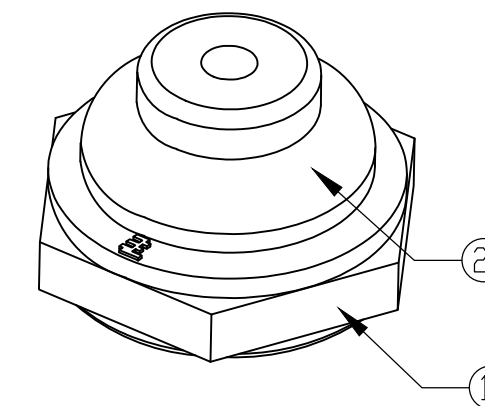
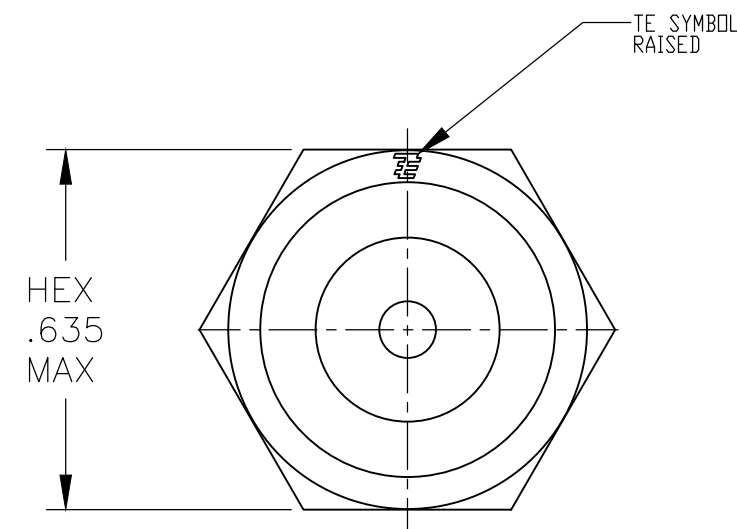

SECTION A-A

- NOTES:
- ALL COLORS AND MATERIALS MADE FROM ONE TOOL.
 - SOME DIMENSIONS MAY VARY DUE TO DIFFERENT COMPOUND SHRINKAGE FACTOR.
 - MINOR FLASH ACCEPTABLE ON INSERT THREAD.
 - BLACK FINISH/NICKEL PLATING ON INSIDE THREADS REMOVED DUE TO MOLDING PROCESS PERMITTED.
 - RUBBER TO METAL BOND MUST MEET OR EXCEED THE TEAR STRENGTH OF RUBBER.
 - RUBBER OVERLAY PERMISSIBLE OVER HEX FLATS AS SHOWN IN THE DRAWING.
 - TREAT WITH PERMANENT LUBRICANT
 - COMPONENTS MUST COMPLY WITH THE EUROPEAN DIRECTIVE 2002/95/EC ON RESTRICTION OF THE USE OF CERTAIN HAZARDOUS SUBSTANCES IN ELECTRICAL AND ELECTRONIC EQUIPMENT (RoHS DIRECTIVE).

	ALCO PART NUMBER	PART NUMBER	HEX NUT MATERIAL	RUBBER BOOT MATERIAL
	BT1532004	1825600-1	BRASS, BLACK OXIDE PER MIL-F-495	SILICONE, COLOR BLACK
OBSELETE	BT1532204	1825600-2	BRASS, NICKEL PLATE PER QQ-N-290	SILICONE, COLOR RED
	BT1532804	1825600-3	BRASS, NICKEL PLATE PER QQ-N-290	SILICONE, COLOR GRAY

NO.	DESCRIPTION	DRAWING NO.	MATERIAL
①	NUT 15/32-32 UNS-2B	HEX NUT 15/32-32	BRASS, FINISH AS PER ABOVE TABLE
②	RUBBER BOOT	RUBBER BOOT	SILICONE PER ZZ-R-765, CLASS 3A, GRADE 50 COLOR AS PER ABOVE TABLE

THIS DRAWING IS A CONTROLLED DOCUMENT.		DWN R BROWN 03JAN2008	TE Connectivity Ltd.																	
DIMENSIONS: INCHES		CHK M WILBOURN 03JAN2008																		
TOLERANCES UNLESS OTHERWISE SPECIFIED:		APVD M WILBOURN 03JAN2008																		
<table border="1"> <tr><td>0 PLC</td><td>±</td><td>-</td></tr> <tr><td>1 PLC</td><td>±</td><td>-</td></tr> <tr><td>2 PLC</td><td>±</td><td>.01</td></tr> <tr><td>3 PLC</td><td>±</td><td>.005</td></tr> <tr><td>4 PLC</td><td>±</td><td>-</td></tr> <tr><td>ANGLES</td><td>±</td><td>-</td></tr> </table>		0 PLC		±	-	1 PLC	±	-	2 PLC	±	.01	3 PLC	±	.005	4 PLC	±	-	ANGLES	±	-
0 PLC	±	-																		
1 PLC	±	-																		
2 PLC	±	.01																		
3 PLC	±	.005																		
4 PLC	±	-																		
ANGLES	±	-																		
MATERIAL	FINISH	WEIGHT	SIZE A2																	
			CAGE CODE 00779																	
			DRAWING NO. C=1825600																	
			RESTRICTED TO																	
CUSTOMER DRAWING			SCALE 3:1																	
			SHEET 1 of 1																	
			REV B1																	