



**MICROCHIP**

---

**MTD6505  
3-Phase BLDC  
Sensorless Fan Controller  
Demonstration Board  
User's Guide**

---

---

**Note the following details of the code protection feature on Microchip devices:**

- Microchip products meet the specification contained in their particular Microchip Data Sheet.
- Microchip believes that its family of products is one of the most secure families of its kind on the market today, when used in the intended manner and under normal conditions.
- There are dishonest and possibly illegal methods used to breach the code protection feature. All of these methods, to our knowledge, require using the Microchip products in a manner outside the operating specifications contained in Microchip's Data Sheets. Most likely, the person doing so is engaged in theft of intellectual property.
- Microchip is willing to work with the customer who is concerned about the integrity of their code.
- Neither Microchip nor any other semiconductor manufacturer can guarantee the security of their code. Code protection does not mean that we are guaranteeing the product as "unbreakable."

Code protection is constantly evolving. We at Microchip are committed to continuously improving the code protection features of our products. Attempts to break Microchip's code protection feature may be a violation of the Digital Millennium Copyright Act. If such acts allow unauthorized access to your software or other copyrighted work, you may have a right to sue for relief under that Act.

---

Information contained in this publication regarding device applications and the like is provided only for your convenience and may be superseded by updates. It is your responsibility to ensure that your application meets with your specifications. MICROCHIP MAKES NO REPRESENTATIONS OR WARRANTIES OF ANY KIND WHETHER EXPRESS OR IMPLIED, WRITTEN OR ORAL, STATUTORY OR OTHERWISE, RELATED TO THE INFORMATION, INCLUDING BUT NOT LIMITED TO ITS CONDITION, QUALITY, PERFORMANCE, MERCHANTABILITY OR FITNESS FOR PURPOSE. Microchip disclaims all liability arising from this information and its use. Use of Microchip devices in life support and/or safety applications is entirely at the buyer's risk, and the buyer agrees to defend, indemnify and hold harmless Microchip from any and all damages, claims, suits, or expenses resulting from such use. No licenses are conveyed, implicitly or otherwise, under any Microchip intellectual property rights.

#### **Trademarks**

The Microchip name and logo, the Microchip logo, dsPIC, KEELOQ, KEELOQ logo, MPLAB, PIC, PICmicro, PICSTART, PIC<sup>32</sup> logo, rPIC and UNI/O are registered trademarks of Microchip Technology Incorporated in the U.S.A. and other countries.

FilterLab, Hampshire, HI-TECH C, Linear Active Thermistor, MXDEV, MXLAB, SEEVAL and The Embedded Control Solutions Company are registered trademarks of Microchip Technology Incorporated in the U.S.A.

Analog-for-the-Digital Age, Application Maestro, chipKIT, chipKIT logo, CodeGuard, dsPICDEM, dsPICDEM.net, dsPICworks, dsSPEAK, ECAN, ECONOMONITOR, FanSense, HI-TIDE, In-Circuit Serial Programming, ICSP, Mindi, MiWi, MPASM, MPLAB Certified logo, MPLIB, MPLINK, mTouch, Omniscient Code Generation, PICC, PICC-18, PICDEM, PICDEM.net, PICkit, PICtail, REAL ICE, rfLAB, Select Mode, Total Endurance, TSHARC, UniWinDriver, WiperLock and ZENA are trademarks of Microchip Technology Incorporated in the U.S.A. and other countries.

SQTP is a service mark of Microchip Technology Incorporated in the U.S.A.

All other trademarks mentioned herein are property of their respective companies.

© 2011, Microchip Technology Incorporated, Printed in the U.S.A., All Rights Reserved.

 Printed on recycled paper.

ISBN: 978-1-61341-886-4

**QUALITY MANAGEMENT SYSTEM**  
**CERTIFIED BY DNV**  
**== ISO/TS 16949:2009 ==**

*Microchip received ISO/TS-16949:2009 certification for its worldwide headquarters, design and wafer fabrication facilities in Chandler and Tempe, Arizona; Gresham, Oregon and design centers in California and India. The Company's quality system processes and procedures are for its PIC<sup>®</sup> MCUs and dsPIC<sup>®</sup> DSCs, KEELOQ<sup>®</sup> code hopping devices, Serial EEPROMs, microperipherals, nonvolatile memory and analog products. In addition, Microchip's quality system for the design and manufacture of development systems is ISO 9001:2000 certified.*



# MTD6505 3-PHASE BLDC SENSORLESS FAN CONTROLLER DEMO BOARD USER'S GUIDE

---

---

## Table of Contents

---

---

|   |           |
|---|-----------|
| <b>Preface</b> .....  | <b>5</b>  |
| Introduction.....   | 5         |
| Document Layout .....   | 5         |
| Conventions Used in this Guide .....  | 6         |
| Recommended Reading.....  | 7         |
| The Microchip Web Site .....  | 7         |
| Customer Support .....  | 7         |
| Document Revision History .....   | 7         |
| <b>Chapter 1. Product Overview</b>  |           |
| 1.1 Introduction .....  | 9         |
| 1.2 MTD6505 3-Phase BLDC Sensorless Fan Controller<br>Demonstration Board Hardware Description .....                              | 10        |
| 1.3 What the MTD6505 3-Phase BLDC Sensorless Fan Controller<br>Demonstration Board Kit Includes .....                             | 10        |
| <b>Chapter 2. Installation and Operation</b>  |           |
| 2.1 Getting Started .....   | 11        |
| 2.1.1 Software Installation .....   | 11        |
| 2.1.2 Board Installation .....  | 11        |
| 2.2 MTD6505 3-Phase BLDC Sensorless Fan Controller Demonstration Board<br>Software Description .....                              | 13        |
| 2.2.1 Controlling and Monitoring Tab .....  | 13        |
| 2.2.2 Measurement Tab .....   | 15        |
| 2.3 How to Define the Correct $R_{\text{PROG}}$ Value .....   | 18        |
| 2.3.1 Operation .....   | 18        |
| <b>Appendix A. Schematics and Layouts</b>   |           |
| A.1 Introduction .....  | 19        |
| A.2 Board – Schematic: Power Management Part and Resistor for<br>Programming Part .....   | 20        |
| A.3 Board – Schematic: Direction Pin Management Part, PIC Reserves Part,<br>and MTD6505 Voltage and Current Monitoring Part ..... | 21        |
| A.4 Board – Schematic: PIC24FJ256GB106 Part .....   | 22        |
| A.5 Board – Schematic: ICPart/MTD6505 Plug-in Module Socket Part,<br>USB Connection Part, LED Part, and Reset Switch Part .....   | 23        |
| A.6 Board – Top Silk and Pads .....   | 24        |
| A.7 Board – Top Trace and Pads .....  | 25        |
| A.8 Board – Bottom Trace and Pads .....   | 26        |
| <b>Appendix B. Bill of Materials</b>  |           |
| <b>Worldwide Sales and Service</b> .....  | <b>30</b> |





# MTD6505 3-PHASE BLDC SENSORLESS FAN CONTROLLER DEMO BOARD USER'S GUIDE

---

---

## Preface

---

---

### NOTICE TO CUSTOMERS

All documentation becomes dated, and this manual is no exception. Microchip tools and documentation are constantly evolving to meet customer needs, so some actual dialogs and/or tool descriptions may differ from those in this document. Please refer to our web site ([www.microchip.com](http://www.microchip.com)) to obtain the latest documentation available.

Documents are identified with a “DS” number. This number is located on the bottom of each page, in front of the page number. The numbering convention for the DS number is “DSXXXXA”, where “XXXX” is the document number and “A” is the revision level of the document.

For the most up-to-date information on development tools, see the MPLAB® IDE online help. Select the Help menu, and then Topics to open a list of available online help files.

## INTRODUCTION

This chapter contains general information that will be useful to know before using the MTD6505 3-Phase BLDC Sensorless Fan Controller Demonstration Board. Items discussed in this chapter include:

- Document Layout
- Conventions Used in this Guide
- Recommended Reading
- The Microchip Web Site
- Customer Support
- Document Revision History

## DOCUMENT LAYOUT

This document describes how to use the MTD6505 3-Phase BLDC Sensorless Fan Controller Demonstration Board as a development tool to emulate and debug firmware on a target board. The manual layout is as follows:

- **Chapter 1. “Product Overview”** – Important information about the MTD6505 3-Phase BLDC Sensorless Fan Controller Demonstration Board.
- **Chapter 2. “Installation and Operation”** – Includes instructions on how to get started with MTD6505 3-Phase BLDC Sensorless Fan Controller Demonstration Board.
- **Appendix A. “Schematics and Layouts”** – Shows the schematic and layout diagrams for the MTD6505 3-Phase BLDC Sensorless Fan Controller Demonstration Board.
- **Appendix B. “Bill of Materials”** – Lists the parts used to build the MTD6505 3-Phase BLDC Sensorless Fan Controller Demonstration Board.

## CONVENTIONS USED IN THIS GUIDE

This manual uses the following documentation conventions:

### DOCUMENTATION CONVENTIONS

| Description                                      | Represents  | Examples  |
|--|---|---|
| <b>Arial font:</b>                               |   |   |
| Italic characters                                | Referenced books  | <i>MPLAB<sup>®</sup> IDE User's Guide</i>                   |
|  | Emphasized text   | ...is the <i>only</i> compiler...                           |
| Initial caps                                     | A window  | the Output window   |
|  | A dialog  | the Settings dialog   |
|  | A menu selection  | select Enable Programmer                                    |
| Quotes   | A field name in a window or dialog  | "Save project before build"                                 |
| Underlined, italic text with right angle bracket | A menu path   | <u><i>File&gt;Save</i></u>                                  |
| Bold characters                                  | A dialog button   | Click <b>OK</b>   |
|  | A tab   | Click the <b>Power</b> tab                                  |
| N'Rnnnn  | A number in verilog format, where N is the total number of digits, R is the radix and n is a digit. | 4'b0010, 2'hF1  |
| Text in angle brackets < >                       | A key on the keyboard   | Press <Enter>, <F1>   |
| <b>Courier New font:</b>                         |   |   |
| Plain Courier New                                | Sample source code  | #define START   |
|  | Filenames   | autoexec.bat  |
|  | File paths  | c:\mcc18\h  |
|  | Keywords  | _asm, _endasm, static                                       |
|  | Command-line options  | -Opa+, -Opa-  |
|  | Bit values  | 0, 1  |
|  | Constants   | 0xFF, 'A'   |
| Italic Courier New                               | A variable argument   | <i>file.o</i> , where <i>file</i> can be any valid filename |
| Square brackets [ ]                              | Optional arguments  | mcc18 [options] <i>file</i> [options]                       |
| Curly brackets and pipe character: {   }         | Choice of mutually exclusive arguments; an OR selection   | errorlevel {0 1}  |
| Ellipses...                                      | Replaces repeated text  | var_name [, var_name...]                                    |
|  | Represents code supplied by user  | void main (void)<br>{ ...<br>}                              |

## RECOMMENDED READING

This user's guide describes how to use MTD6505 3-Phase BLDC Sensorless Fan Controller Demonstration Board. Other useful documents are listed below. The following Microchip documents are available and recommended as supplemental reference resources.

- **MTD6505 Data Sheet**, “3-Phase BLDC Sinusoidal Sensorless Fan Motor Drive” (DS22281)

## THE MICROCHIP WEB SITE

Microchip provides online support via our web site at [www.microchip.com](http://www.microchip.com). This web site is used as a means to make files and information easily available to customers. Accessible by using your favorite Internet browser, the web site contains the following information:

- **Product Support** – Data sheets and errata, application notes and sample programs, design resources, user's guides and hardware support documents, latest software releases and archived software
- **General Technical Support** – Frequently Asked Questions (FAQs), technical support requests, online discussion groups, Microchip consultant program member listing
- **Business of Microchip** – Product selector and ordering guides, latest Microchip press releases, listing of seminars and events, listings of Microchip sales offices, distributors and factory representatives

## CUSTOMER SUPPORT

Users of Microchip products can receive assistance through several channels:

- Distributor or Representative
- Local Sales Office
- Field Application Engineer (FAE)
- Technical Support

Customers should contact their distributor, representative or field application engineer (FAE) for support. Local sales offices are also available to help customers. A listing of sales offices and locations is included in the back of this document.

Technical support is available through the web site at: <http://www.microchip.com/support>.

## DOCUMENT REVISION HISTORY

### Revision A (December 2011)

- Initial Release of this Document.

**NOTES:**



**Chapter 1. Product Overview**

**1.1 INTRODUCTION**

The MTD6505 3-Phase BLDC Sensorless Fan Controller Demonstration Board allows the control and monitoring of the MTD6505 device, using a PC software connected to the MTD6505 3-Phase BLDC Sensorless Fan Controller Demonstration Board via a USB connection.

The MTD6505 3-Phase BLDC Sensorless Fan Controller Demonstration Board Software provides several features, such as  $V_{DD}$  control and monitoring, pulse-width modulation (PWM) control, speed and current consumption monitoring. It also allows controlling the  $R_{PROG}$  resistor value for fan fitting.

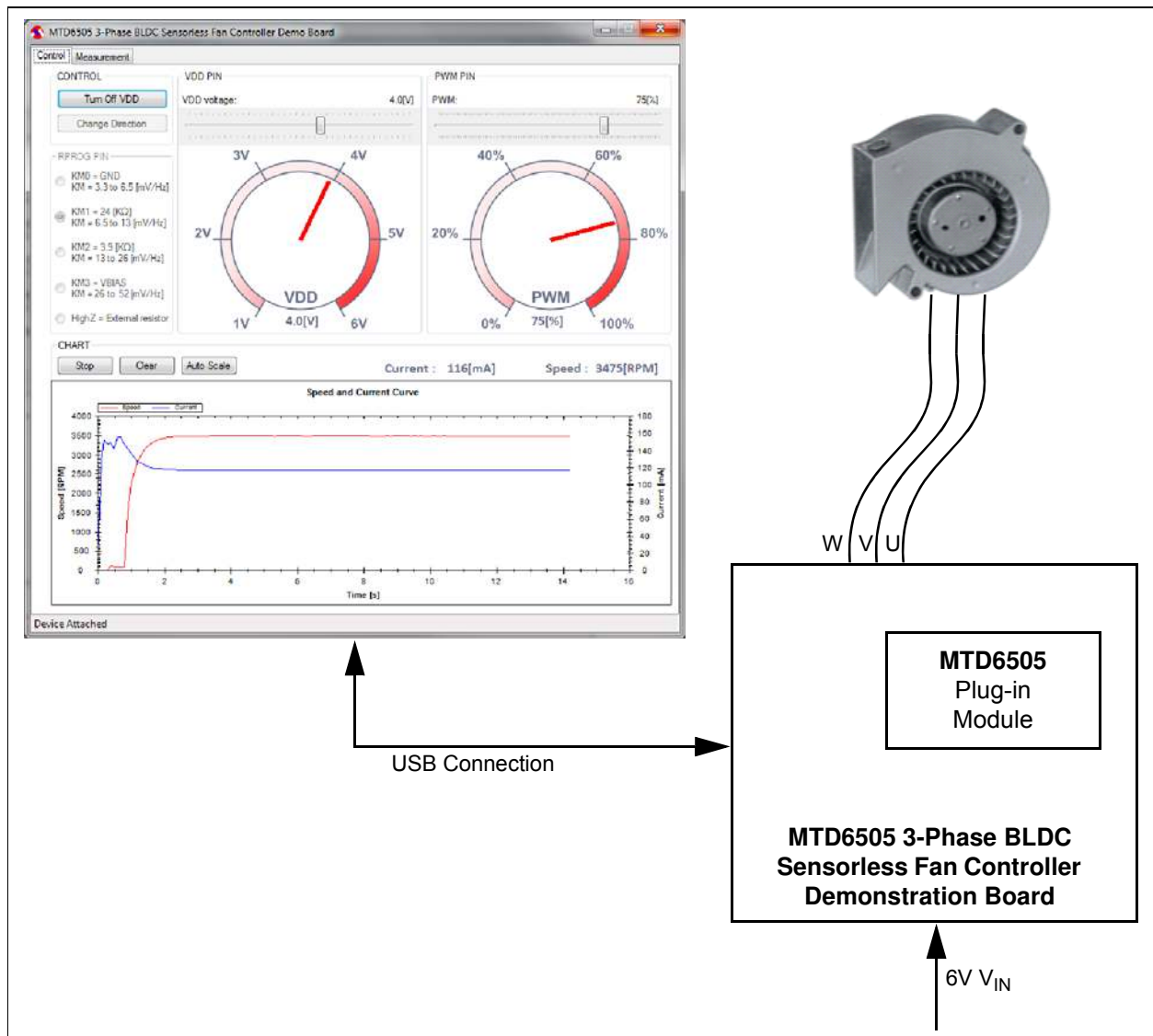

**FIGURE 1-1:** System Overview.

## 1.2 MTD6505 3-PHASE BLDC SENSORLESS FAN CONTROLLER DEMONSTRATION BOARD HARDWARE DESCRIPTION

The MTD6505 3-Phase BLDC Sensorless Fan Controller Demonstration Board contains several components, such as:

- A microcontroller (PIC24FJ256GB) for USB connection, PWM generation, FG frequency measurement,  $V_{DD}$  measurement, other's signal's activations and component's communication.
- An adjustable LDO (MCP1827) combined to a digital potentiometer (MCP42050) to provide the  $V_{DD}$  to the MTD6505 device. The LDO can be enabled or disabled by the microcontroller.
- The digital potentiometer is also used to set the MTD6505  $R_{PROG}$  external resistor value.
- A Delta-Sigma (MCP3421) combined to a shunt resistor for sensing the MTD6505 current consumption on the  $V_{DD}$  pin.

More details of the schematic are available in [Appendix A. "Schematics and Layouts"](#).

## 1.3 WHAT THE MTD6505 3-PHASE BLDC SENSORLESS FAN CONTROLLER DEMONSTRATION BOARD KIT INCLUDES

The MTD6505 3-Phase BLDC Sensorless Fan Controller Demonstration Board includes:

- MTD6505 3-Phase BLDC Sensorless Fan Controller Demonstration Board (ADM00345)
- 3 x MTD6505 plug-in modules with soldered on MTD6505 (3x3 UDFN-10L)
- A mini-USB cable
- A 3-Phase BLDC fan (use with  $K_M=1$ )
- Important Information Sheet

## Chapter 2. Installation and Operation

### 2.1 GETTING STARTED

The following sections describe how to use the MTD6505 3-Phase BLDC Sensorless Fan Controller Demonstration Board.

#### 2.1.1 Software Installation

Download the MTD6505 3-Phase BLDC Sensorless Fan Controller Demonstration Board software installer from the Microchip web site at <http://www.microchip.com>. From the web site, search for the evaluation board by part number ADM00345. The GUI can be downloaded from this web page.

**Note:** This application requires Microsoft .NET Framework 2.0 or later.

#### 2.1.2 Board installation

Figure 2-1 identifies the required points for using the MTD6505 3-Phase BLDC Sensorless Fan Controller Demonstration Board.

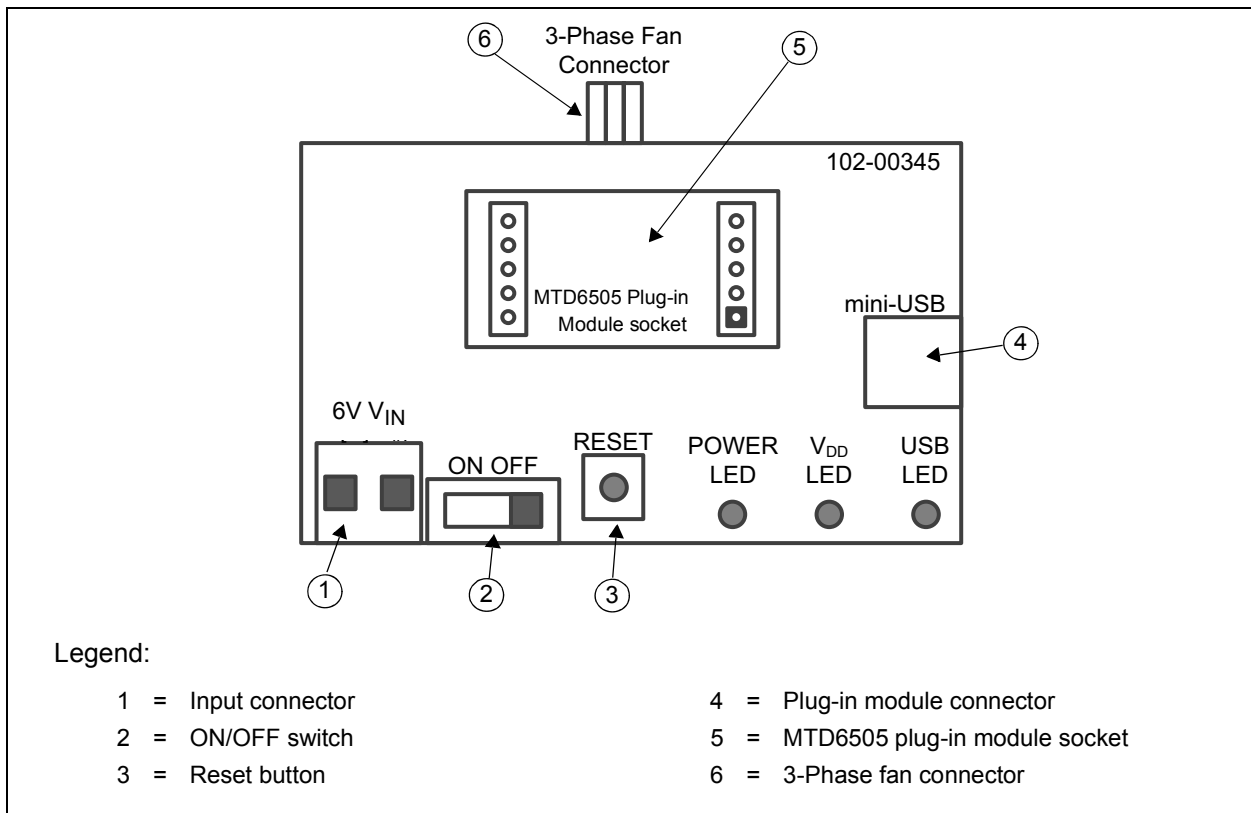

**FIGURE 2-1:** Top View - Hardware Components.

To use the MTD6505 3-Phase BLDC Sensorless Fan Controller Demonstration Board, follow the next steps:

1. Plug in the MTD6505 plug-in module (with an MTD6505 soldered on it) on its socket (see [Figure 2-1](#)).
2. To plug in a 3-Phase BLDC sensorless fan, choose one of these connections:
  - 3-Phase fan connector from the MTD6505 3-Phase BLDC Sensorless Fan Controller Demonstration Board (J5)
  - On the MTD6505 plug-in module fan connector.
3. Connect the Power Supply to the  $V_{IN}$  test point.  $V_{IN}$  value is +6V  $\pm$ 5%. The Power Supply should be able to deliver up to 1.0A.
4. Turn on the power switch. The POWER LED should be activated.
5. Plug the mini-USB cable from the USB port of a computer to the MTD6505 3-Phase BLDC Sensorless Fan Controller Demonstration Board connector.
6. If required, let the computer identify the MTD6505 3-Phase BLDC Sensorless Fan Controller Demonstration Board.
7. Restart the computer, if required.
8. Start the MTD6505 3-Phase BLDC Sensorless Fan Controller Demonstration Board Software.

**Note:** Once the MTD6505 3-Phase BLDC Sensorless Fan Controller Demonstration Board Software is installed, it will automatically detect if the MTD6505 3-Phase BLDC Sensorless Fan Controller Demonstration Board is attached and its configuration. This means it is possible to start the MTD6505 3-Phase BLDC Sensorless Fan Controller Demonstration Board Software before or after enabling the board.

## 2.2 MTD6505 3-PHASE BLDC SENSORLESS FAN CONTROLLER DEMONSTRATION BOARD SOFTWARE DESCRIPTION

The MTD6505 3-Phase BLDC Sensorless Fan Controller Demonstration Board Software window contains two tabs. The first tab is for controlling and monitoring the MTD6505 3-Phase BLDC Sensorless Fan Controller Demonstration Board; the second tab is the Measurement tab.

### 2.2.1 Controlling and Monitoring Tab

Figure 2-2 shows the options and functions available to control and monitor the board.

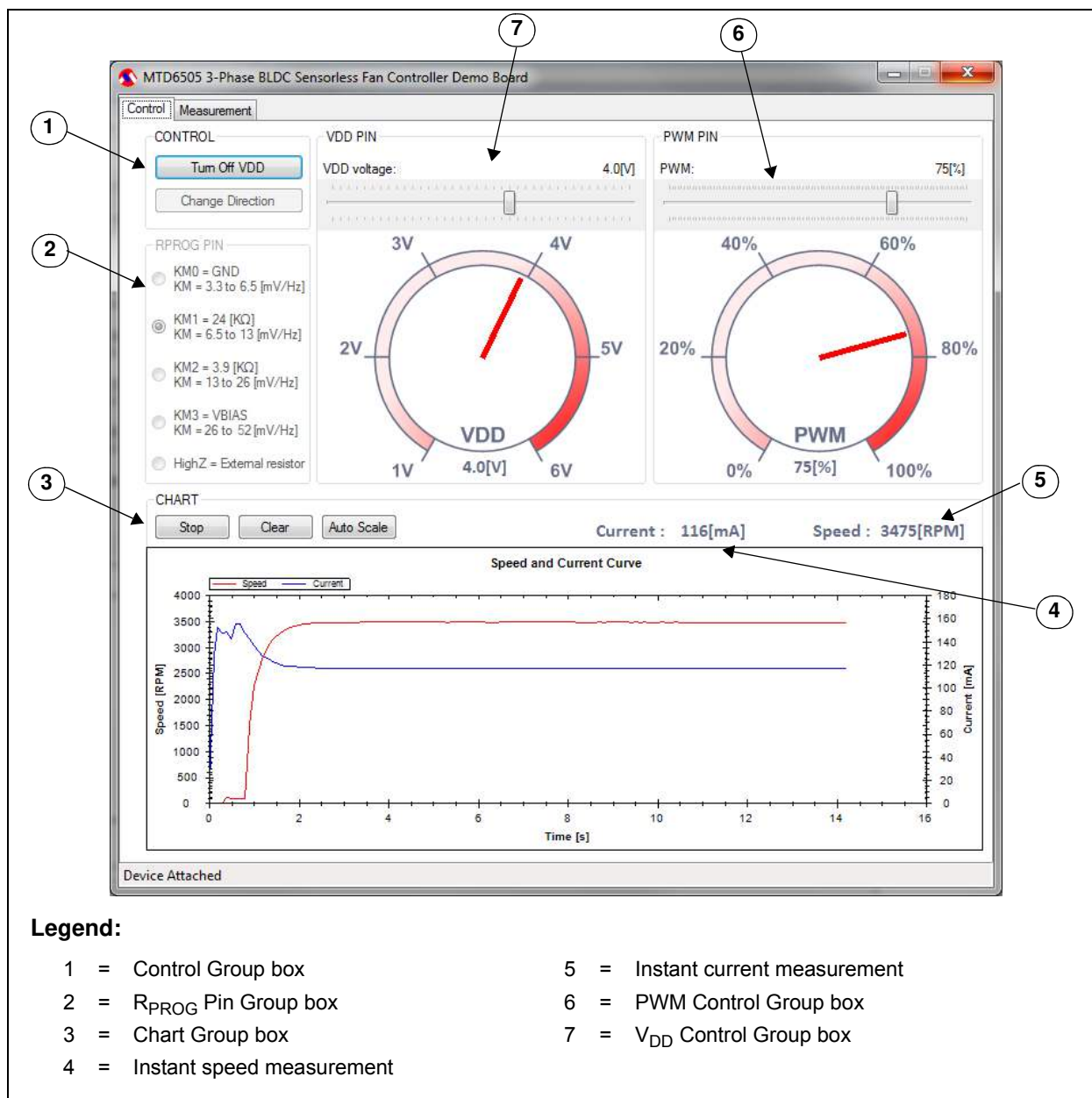

**FIGURE 2-2:** GUI - Controlling and Monitoring Tab.

All functions presented in Figure 2-2 are enabled only when the MTD6505 3-Phase BLDC Sensorless Fan Controller Demonstration Board is connected to the PC via a USB connection.

### 2.2.1.1 CONTROL/MONITORING

The Control/Monitoring Group box contains two buttons:

- **Turn On/Off VDD** button enables/disables the power supply on the  $V_{DD}$  pin of the MTD6505 device.
- **Change Direction** is used to inverse the sense of the fan rotation. The **Change Direction** button is available only when  $V_{DD}$  is turned off.

### 2.2.1.2 $R_{PROG}$ PIN

The  $R_{PROG}$  Pin Group box allows the selection of the desired  $R_{PROG}$  resistor value. This value depends on the  $K_M$  (mV/Hz) of the fan. See the section [Section 2.3 “How to define the correct  \$R\_{PROG}\$  Value”](#) for more information on the  $R_{PROG}$  selection.

One particular mode, HighZ, allows the setting of an external  $R_{PROG}$  resistor value directly on the plug-in module.

In order to use the MTD6502B with the MTD6505 3-Phase BLDC Sensorless Fan Controller Demo Board, use  $K_M = 0$ .

### 2.2.1.3 CHART

This part of the GUI displays a chart of the MTD6505 current consumption (mA) on the  $V_{DD}$  pin, and the fan speed (Revolutions Per Minute - RPM) by measuring the FG frequency. The chart adds 10 values per second. The three buttons have the following functions:

- **Start/Stop** – allows the values acquisition to start or stop
- **Clear** – removes all the values added to the chart
- **Auto Scale** – allows the restoration of the default scaling. In the default scaling mode, the chart will automatically adjust the scaling to ensure the complete view of the whole added values. In addition, when selecting a part of the chart with the mouse, it is possible to zoom in the selection. The mouse wheel zoom in/out is also enabled.

### 2.2.1.4 PWM PIN

The PWM Group box provides a slide bar to set the PWM ratio on the MTD6505 PWM pin. The gauge below indicates the current PWM applied.

### 2.2.1.5 $V_{DD}$ PIN

The  $V_{DD}$  Group box also provides a slide bar to set the desired  $V_{DD}$  value. The gauge below indicates the instant  $V_{DD}$  value measured by the MTD6505 3-Phase BLDC Sensorless Fan Controller Demonstration Board.

### 2.2.1.6 CURRENT/SPEED FIELDS

Current field shows the instant current measure (mA). Speed field shows the instant speed measure (RPM).

## 2.2.2 Measurement Tab

The **Measurement** tab is used to check if the fan is correctly adapted to the MTD6505 by testing the fan several times in different conditions. This tab contains two more tabs, for settings and results.

### 2.2.2.1 SETTINGS TAB

Figure 2-3 shows the **Setting** tab.

**Legend:**

- 1 = Measurement Settings Group box
- 2 = Startup measurement
- 3 = PWM Change Measurement Group box
- 4 = Speed Curve and Stability Measurement Group box
- 5 = Measurement Control Group box

**FIGURE 2-3:** GUI - Measurement tab – Settings.

### 2.2.2.1.1 Measurement Settings

The **Measurement Settings** Group box is used to specify the measurement corners required:

- **Number of iterations** – for one corner
- **PWM Corners Measurement** – requires the PWM Max (%), PWM Step (%) and PWM Min (%) values setting. The software will start with the maximum value entered, and will decrease the PWM by the step value until reaches the minimum entered PWM value.
- **V<sub>DD</sub> corners** are similar to the PWM corners. A V<sub>DD</sub> corner includes all PWM corners. This means that for one V<sub>DD</sub> corner, all PWM corners are measured.
- **Startup max delay** – if the speed of the fan is measured as 0 RPM after this delay, the startup is considered a fail. The recommended value for this field is 3s.
- **Inter test delay** – specifies how many seconds are allocated to stop the fan between two tests. This value will depend on the fan lag.

### 2.2.2.1.2 Startup

When the **Startup** box is checked, the startup measurements are enabled, measuring every corner for this test. If **Startup** is not enabled, the Startup test is skipped. The other tests will be executed if they are enabled.

### 2.2.2.1.3 PWM Change

The PWM Change Measurement starts up with a PWM value of 100%. After the specified startup delay (entered in the Startup max delay field), the PWM changes depending on the PWM corner specified. The software will then verify if the fan is still running. This last check will occur after a delay value is specified in the **Braking Delay (s)** field.

### 2.2.2.1.4 Speed Curve and Stability

This measurement requires a specified number of samples in a specified condition to check speed stability. If the **Do every percent PWM** and/or **Do every 0.1(V) for V<sub>DD</sub>** are not checked, the corners are measured. For this test, the iterations numbering will always be 1. When the **Do every percent PWM** option is enabled, the software will override the specified settings, and the measurement will occur for every PWM; the same procedure will happen for V<sub>DD</sub>, if the check box **Do every 0.1[V] for V<sub>DD</sub>** is checked.

### 2.2.2.1.5 Measurement Control

This group box contains three buttons that allows the user to control the work flow:

- **Stop Measuring** – starts and stops the required measuring
- **Clear Result** – clears the current result from the screen
- **Save Results** – stores the current measurement in an Excel file



## 2.2.2.2 MEASUREMENT RESULTS TAB

Figure 2-4 shows the Measurement Results sub-tab:

| Test Name  | Item Number | PWM [%] | VDD [V] | FG [rpm] | Current [mA] | Startup Success | PWM Ch Success |
|------------|-------------|---------|---------|----------|--------------|-----------------|----------------|
| Startup    | 1           | 100     | 5       | 0        | 0            | True            | True           |
| Startup    | 2           | 100     | 5       | 0        | 0            | True            | True           |
| Startup    | 3           | 100     | 5       | 0        | 0            | True            | True           |
| Startup    | 4           | 100     | 5       | 0        | 0            | True            | True           |
| Startup    | 5           | 100     | 5       | 0        | 0            | True            | True           |
| Startup    | 6           | 100     | 5       | 0        | 0            | True            | True           |
| Startup    | 7           | 100     | 5       | 0        | 0            | True            | True           |
| Startup    | 8           | 100     | 5       | 0        | 0            | True            | True           |
| Startup    | 9           | 100     | 5       | 0        | 0            | True            | True           |
| Startup    | 10          | 100     | 5       | 0        | 0            | True            | True           |
| PWM Change | 1           | 50      | 5       | 0        | 0            | True            | True           |
| PWM Change | 2           | 50      | 5       | 0        | 0            | True            | True           |
| PWM Change | 3           | 50      | 5       | 0        | 0            | True            | True           |
| PWM Change | 4           | 50      | 5       | 0        | 0            | True            | True           |
| PWM Change | 5           | 50      | 5       | 0        | 0            | True            | True           |
| PWM Change | 6           | 50      | 5       | 0        | 0            | True            | True           |
| PWM Change | 7           | 50      | 5       | 0        | 0            | True            | True           |
| PWM Change | 8           | 50      | 5       | 0        | 0            | True            | True           |
| PWM Change | 9           | 50      | 5       | 0        | 0            | True            | True           |
| PWM Change | 10          | 50      | 5       | 0        | 0            | True            | True           |

Measurement Control

Stop Measuring Clear Results Save Results Current Test : Startup, 5[V], 100[%], item n°2

Device AttachedState

**Legend:**

- 1 = Measurement Results table
- 2 = Measurement Control Group box

**FIGURE 2-4:** GUI - Measurement – Results Tab.

The results are stored in this table. All the tests have the first six columns in common, with the other columns being significant only for a specific test. Settings' control buttons are also visible in this tab (see description in [Section 2.2.2.1.5 “Measurement Control”](#)).

**2.3 HOW TO DEFINE THE CORRECT R<sub>PROG</sub> VALUE**

This section explains how to define the correct K<sub>M</sub> value for a specific fan. The K<sub>M</sub> is linked to the R<sub>PROG</sub> (see [Table 2-1](#)). An incorrect K<sub>M</sub> selection can create issues, or reduce the efficiency.

**2.3.1 Operation**

Follow the next steps to define the right R<sub>PROG</sub> value:

1. Apply a constant stream of air to a fan that is not connected.
2. Using an oscilloscope, measure the waveform between two phases, when the fan is rotating.
3. Measure the generated peak-to-peak voltage (V<sub>p-p</sub>) value and the frequency (f).
4. Compute K<sub>M</sub> based on the measured V<sub>p-p</sub> and f (in mV/Hz):

**EQUATION 2-1: K<sub>M</sub> COMPUTE**

$$K_m = \frac{V_{p-p}}{2f}$$

K<sub>M</sub> should be constant, for all fan rotation speeds, but for the K<sub>M</sub> measurement, the fan rotation speed due to the air stream, should be close to the nominal fan rotation speed.

[Table 2-1](#) shows the corresponding K<sub>M</sub> for different R<sub>PROG</sub> values.

**TABLE 2-1: R<sub>PROG</sub> VALUE**

| R <sub>PROG</sub>      | K <sub>M</sub> | K <sub>M</sub> Range (mV/Hz) |
|------------------------|----------------|------------------------------|
| V <sub>BIAS</sub> (0Ω) | 3              | 26 - 52                      |
| 3.9 kΩ                 | 2              | 13 - 26                      |
| 24 kΩ                  | 1              | 6.5 - 13                     |
| GND                    | 0              | 3.25 - 6.5                   |



# MTD6505 3-PHASE BLDC SENSORLESS FAN CONTROLLER DEMO BOARD USER'S GUIDE

---

---

## Appendix A. Schematics and Layouts

---

---

### A.1 INTRODUCTION

This appendix contains the following schematics and layouts for the MTD6505 3-Phase BLDC Sensorless Fan Controller Demonstration Board:

- Board - Schematic: Power Management Part and Resistor for Programming Part
- Board – Schematic: Direction Pin Management Part, PIC Reserves Part and MTD6505 Voltage and Current Monitoring Part
- Board – Schematic: PIC24FJ256GB106 Part
- Board – Schematic: IC Part/MTD6505 Plug-in Module Socket Part, USB Connection Part, LED Part and Reset Switch Part
- Board – Top Silk and Pads
- Board – Top Trace and Pads
- Board – Bottom Trace and Pads

A.2 BOARD – SCHEMATIC: POWER MANAGEMENT PART AND RESISTOR FOR PROGRAMMING PART

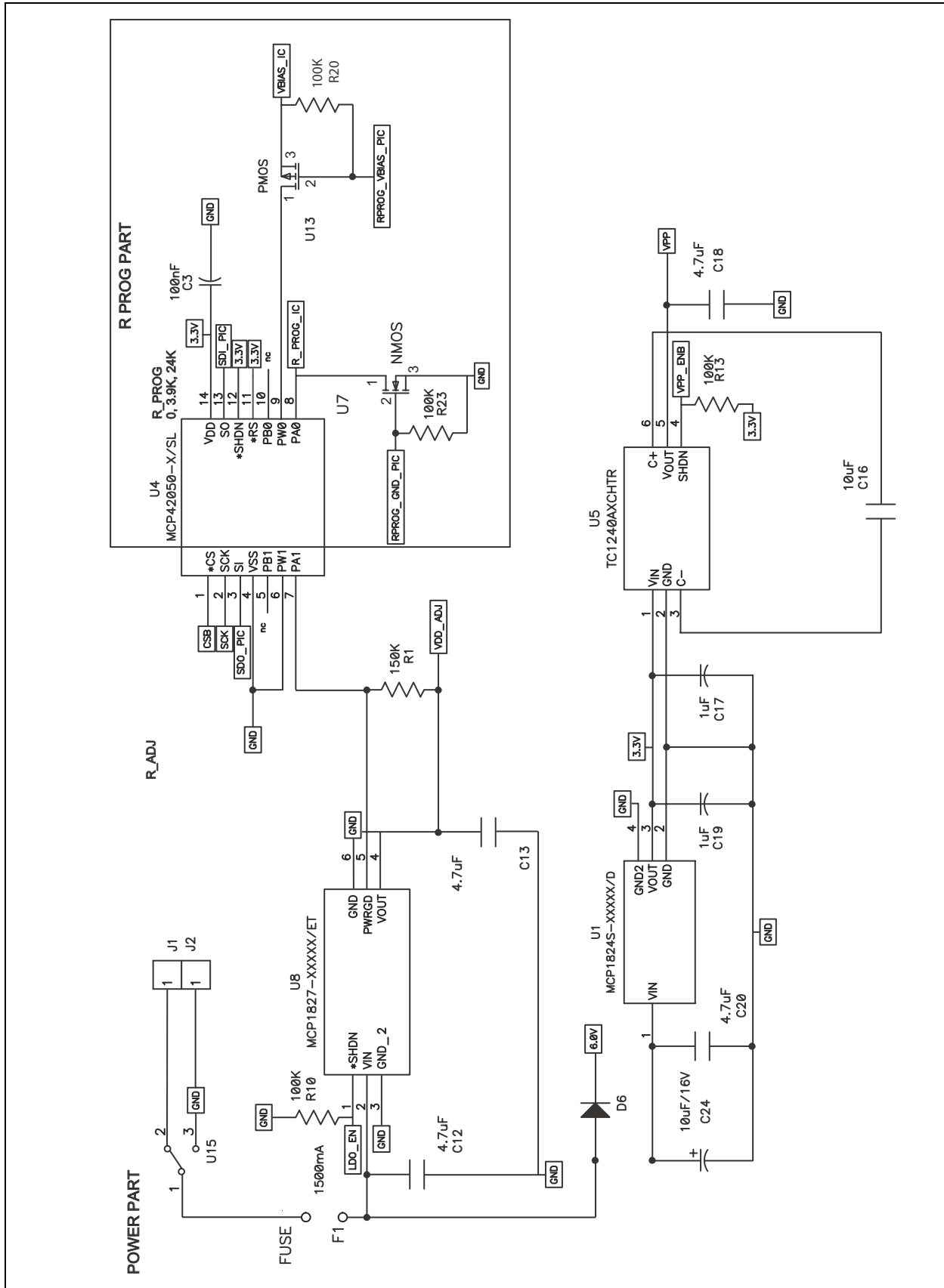

## A.3 BOARD – SCHEMATIC: DIRECTION PIN MANAGEMENT PART, PIC RESERVES PART, AND MTD6505 VOLTAGE AND CURRENT MONITORING PART

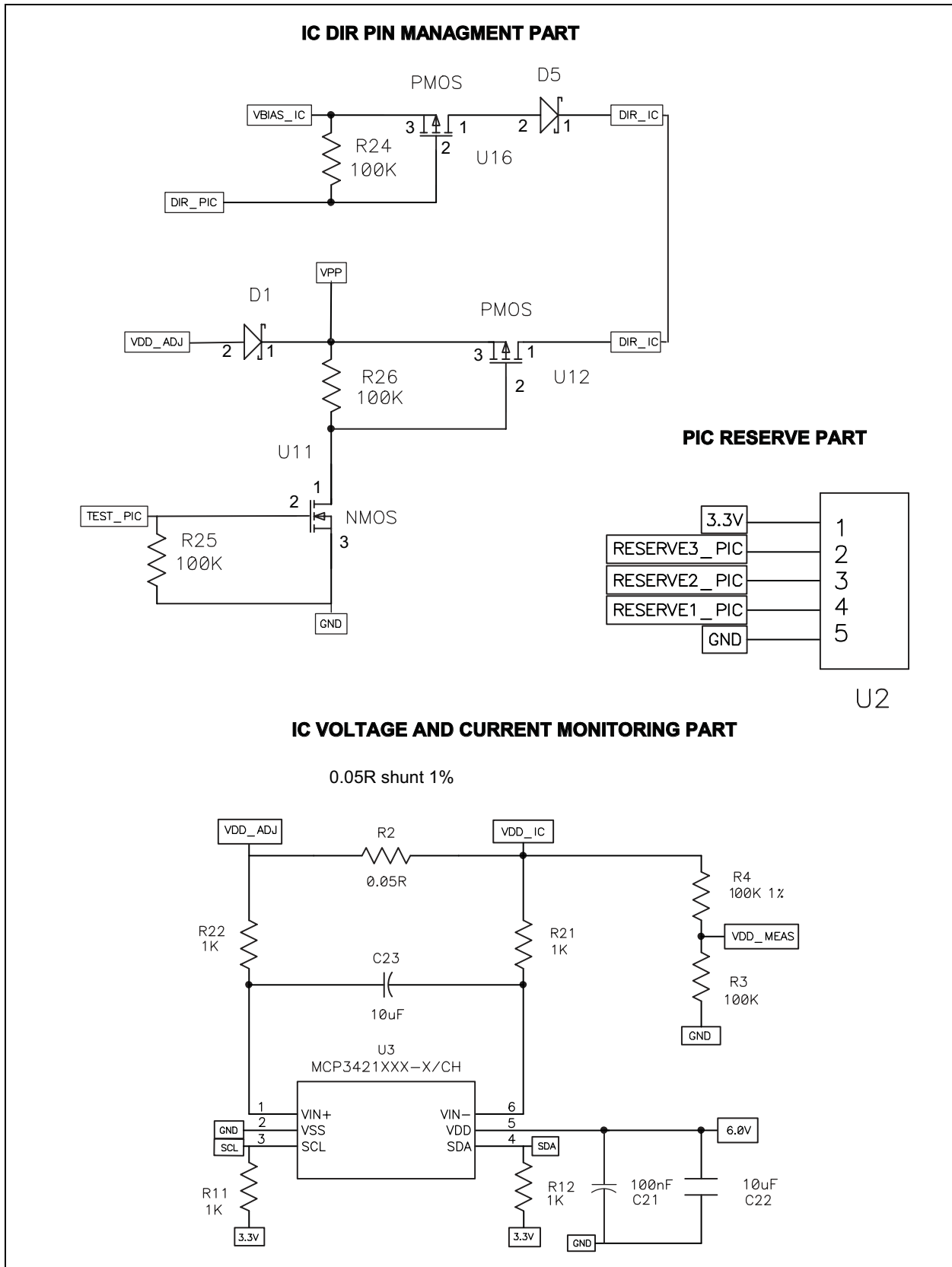

### A.4 BOARD – SCHEMATIC: PIC24FJ256GB106 PART

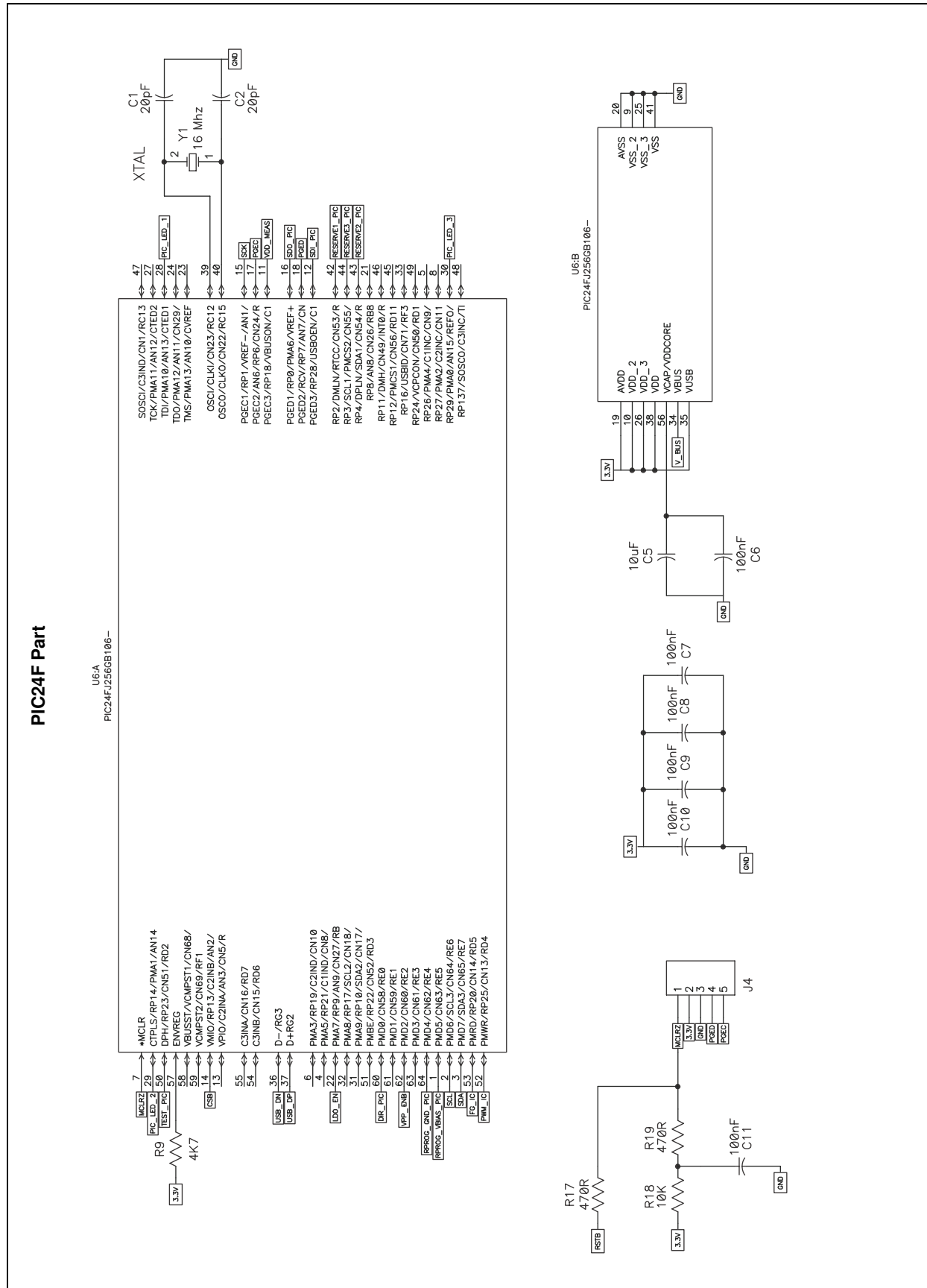

## A.5 BOARD – SCHEMATIC: IC PART/MTD6505 PLUG-IN MODULE SOCKET PART, USB CONNECTION PART, LED PART, AND RESET SWITCH PART

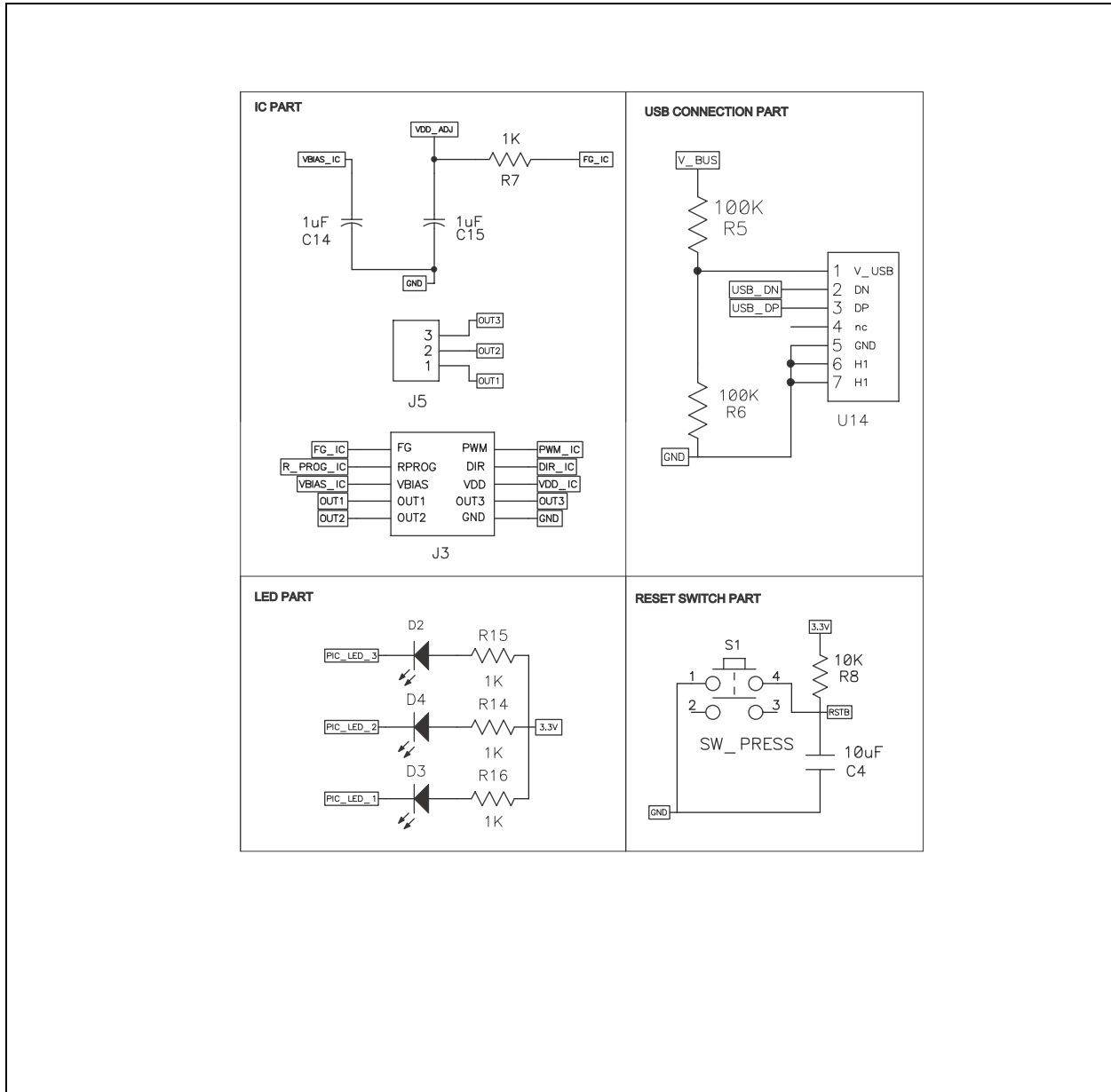

A.6 BOARD – TOP SILK AND PADS

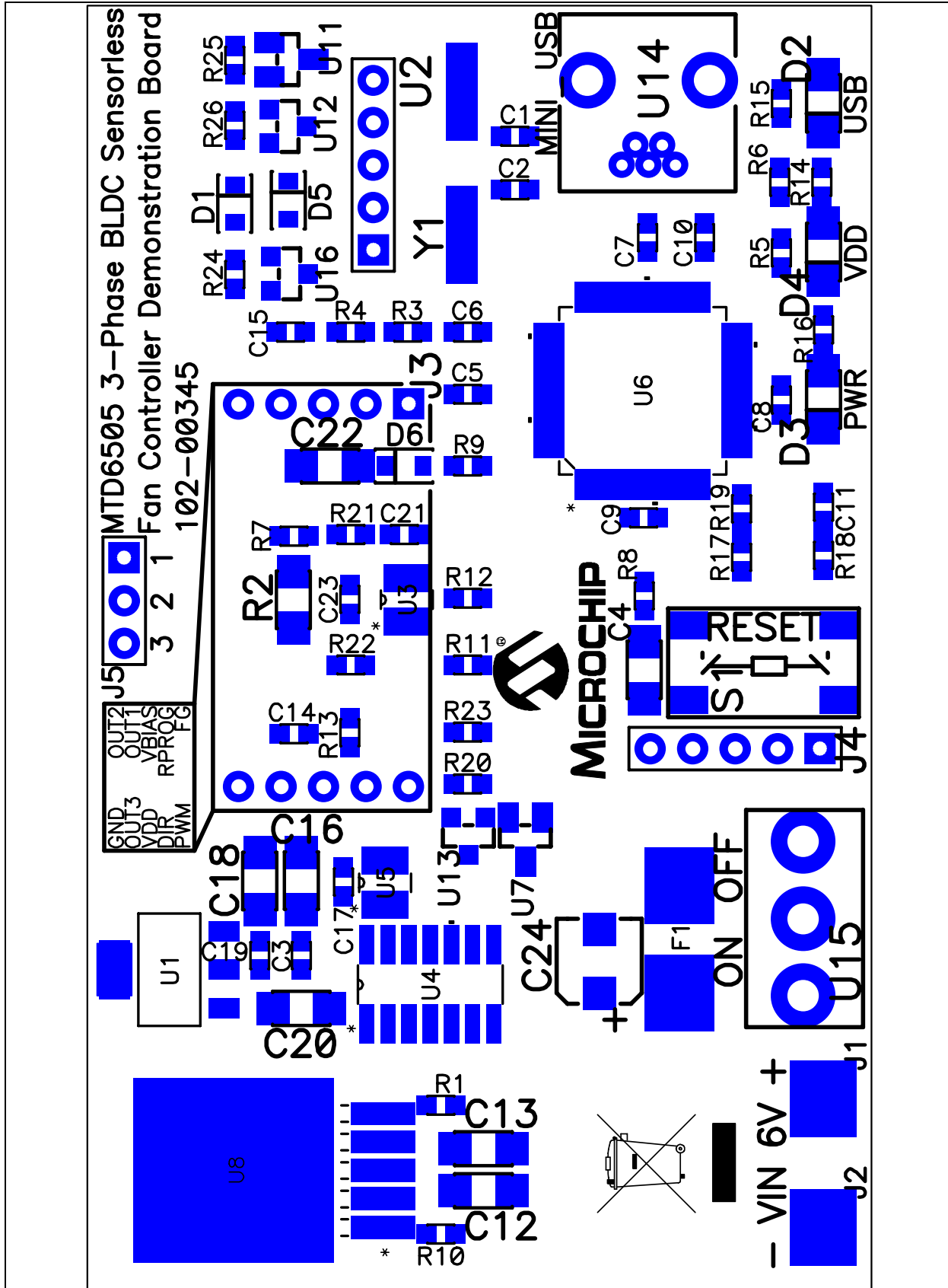



## A.7 BOARD – TOP TRACE AND PADS

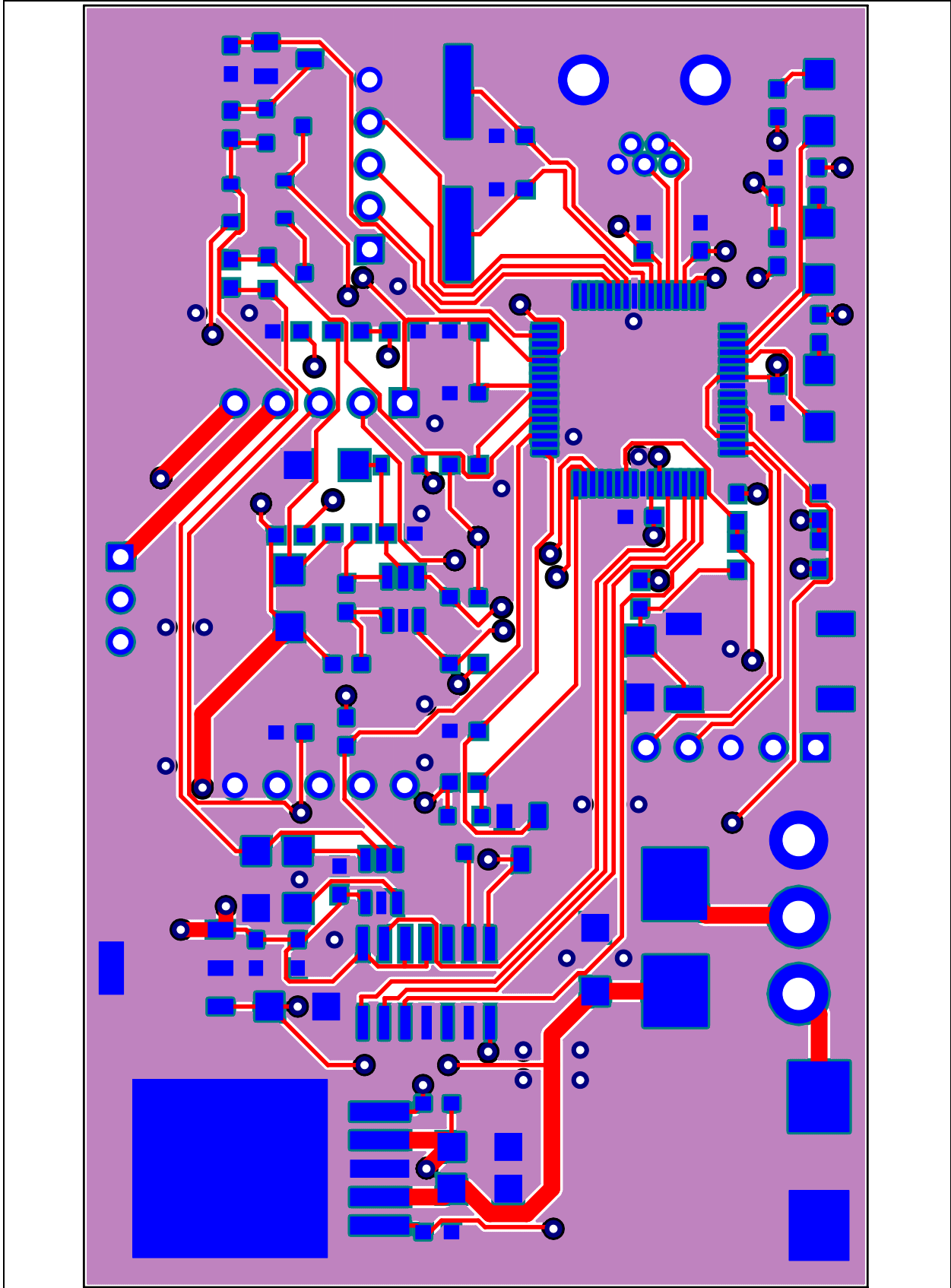

A.8 BOARD – BOTTOM TRACE AND PADS

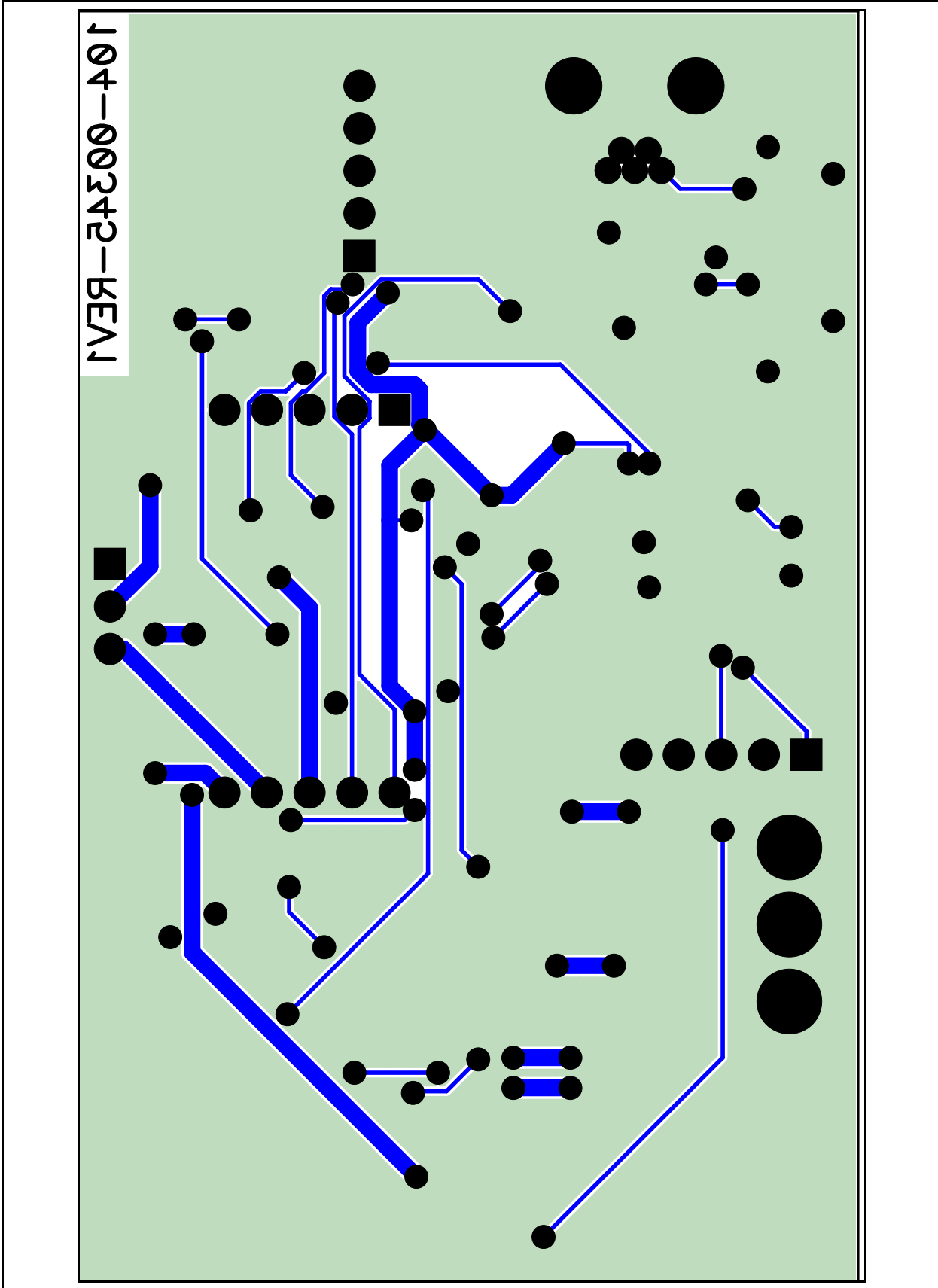



# MTD6505 3-PHASE BLDC SENSORLESS FAN CONTROLLER DEMO BOARD USER'S GUIDE

## Appendix B. Bill of Materials

**TABLE B-1: BILL OF MATERIALS (BOM)**

| Qty | Reference                                 | Description                                     | Manufacturer                         | Part Number        |
|-----|---|---|--------------------------------------|--------------------|
| 2   | C1, C2                                    | CAP CER 20PF 50V C0G 0603                       | TDK <sup>®</sup> Corporation         | C1608C0G1H200J     |
| 8   | C3, C6, C7, C8, C9, C10, C11, C21         | CAP CER .1UF 16V 10% X7R 0603                   | Murata Electronics <sup>®</sup>      | GRM188R71C104KA01D |
| 3   | C4, C16, C22                              | CAP CERAMIC 10.0UF 16V X5R 1206                 | KEMET <sup>®</sup> Electronics Corp. | C1206C106K4PACTU   |
| 2   | C5, C23                                   | CAP CER 10UF 6.3V X5R 0603                      | KEMET Electronics Corp.              | C0603C106M9PACTU   |
| 4   | C12, C13, C18, C20                        | CAP CERAMIC 4.7UF 16V X7R 1206                  | KEMET Electronics Corp.              | C1206C475K4RACTU   |
| 4   | C14, C15, C17, C19                        | CAP CER 1.0UF 16V 10% X5R 0603                  | Murata Electronics                   | GRM188R61C105KA93D |
| 1   | C24                                       | CAP ALUM 10UF 16V 20% SMD                       | Panasonic <sup>®</sup> - ECG         | EEE-HC1C100R       |
| 2   | D1, D5, D6                                | DIODE SCHOTTKY 30V 200MA SC-76                  | NXP Semiconductors                   | 1PS76SB10,115      |
| 3   | D2, D3, D4                                | LED INGAN BLUE CLEAR 1206 SMD                   | Dialight Corp.                       | 598-8291-107F      |
| 1   | D6  | DIODE ZENER 12V 400MW SOD323                    | NXP Semiconductors                   | PDZ12B,115         |
| 1   | F1 Fuse                                   | 044901.5MR - FUSE, SMD, 1.5A, TIME DELAY        | Littelfuse <sup>®</sup>              | 044901.5MR         |
| 1   | F1 Holder                                 | 0154007.DR - FUSE BLOCK W/ 7A FUSE, FAST ACTING | Littelfuse                           | R154007            |
| 1   | J1, J2                                    | PC TEST POINT COMPACT SMT                       | Keystone Electronics                 | 5016               |
| 3   | J3, J3, U2                                | CONN RCPT .100" 5POS SNGL TIN                   | Samtec, Inc.                         | SLW-105-01-T-S     |
| 1   | J4  | CONN HDR BRKWAY .100 05POS VERT                 | TE Connectivity                      | 9-146282-0-05      |
| 1   | J5  | CONN HDR BRKWAY .100 03POS VERT                 | TE Connectivity                      | 9-146282-0-03      |
| 1   | R1  | RES 150K OHM 1/10W 5% 0603 SMD                  | Panasonic - ECG                      | ERJ-3GEYJ154V      |
| 1   | R2  | RES .05 OHM 1W 1% 1206 SMD                      | Vishay <sup>®</sup> /Dale            | WSLP1206R0500FEA   |
| 2   | R3, R4                                    | RES 100K OHM 1/10W 1% 0603 SMD                  | Panasonic - ECG                      | ERJ-3EKF1003V      |
| 9   | R5, R6, R10, R13, R20, R23, R24, R25, R26 | RES 100K OHM 1/10W 5% 0603 SMD                  | Panasonic - ECG                      | ERJ-3GEYJ104V      |
| 8   | R7, R11, R12, R14, R15, R16, R21, R22     | RES 1.0K OHM 1/10W 5% 0603 SMD                  | Panasonic - ECG                      | ERJ-3GEYJ102V      |

**Note 1:** The components listed in this Bill of Materials are representative of the PCB assembly. The released BOM used in manufacturing uses all RoHS-compliant components.

## MTD6505 3-Phase BLDC Sensorless Fan Controller Demonstration Board

**TABLE B-1: BILL OF MATERIALS (BOM) (CONTINUED)**

| Qty | Reference        | Description   | Manufacturer                            | Part Number            |
|-----|------------------|---|---|------------------------|
| 2   | R8, R18          | RES 10K OHM 1/10W 5% 0603 SMD   | Panasonic - ECG                         | ERJ-3GEYJ103V          |
| 1   | R9               | RES 4.7K OHM 1/10W 5% 0603 SMD  | Panasonic - ECG                         | ERJ-3GEYJ472V          |
| 2   | R17, R19         | RES 470 OHM 1/10W 5% 0603 SMD   | Panasonic - ECG                         | ERJ-3GEYJ471V          |
| 1   | S1               | SWITCH, TACTILE SPST 50mA,<br>SMD GULL WING   | TE Connectivity<br>Alcoswitch           | FSM2JSMATR             |
| 1   | U1               | 300 mA, Low Voltage, Low Quiescent<br>Current LDO Regulator                                     | Microchip Technology<br>Inc.            | MCP1824S-3302E/DB:3.3V |
| 1   | U3               | 18-Bit Analog-to-Digital Converter<br>with I <sup>2</sup> C Interface and On-Board<br>Reference | Microchip Technology<br>Inc.            | MCP3421A0T-E/CH        |
| 1   | U4               | Single/Dual Digital Potentiometer with<br>SPI Interface   | Microchip Technology<br>Inc.            | MCP42050-E/SL          |
| 1   | U5               | Positive Doubling Charge Pumps with<br>Shutdown   | Microchip Technology<br>Inc.            | TC1240AXCHTR           |
| 1   | U6               | 64-Pin, 16-Bit Flash Microcontroller<br>with USB On-The-Go (OTG)                                | Microchip Technology<br>Inc.            | PIC24FJ256GB106-I/PT   |
| 2   | U7, U11          | MOSFET N-CH 20V 1.2A SC59-3   | Diodes Incorporated <sup>®</sup>        | DMN2112SN-7            |
| 1   | U8               | 1.5A, Low Voltage, Low Quiescent<br>Current LDO Regulator                                       | Microchip Technology<br>Inc.            | MCP1827-ADJE/ET        |
| 3   | U12, U13,<br>U16 | MOSFET P-CH 20V 1A SSOT3  | Fairchild<br>Semiconductor <sup>®</sup> | NDS332P                |
| 1   | U14              | Plug-in Module connector Type B<br>(USB 2.0)  | Hsuan Mao Technology<br>Co., Ltd        | C8320-05BFRSB0R        |
| 1   | U15              | SLIDE SWITCH, SPDT  | Knitter-Switch                          | MFP106D                |
| 1   | Y1               | CRYSTAL, HC49/SMD, 16.000MHZ  | Aker Technology                         | CAA-16.000-18-3050-X   |
| 1   | FAN              | 3-Phase BLDC Fan  | Kunshan Kipo<br>Technology Co., LTD     | FAKL600EPA             |

**Note 1:** The components listed in this Bill of Materials are representative of the PCB assembly. The released BOM used in manufacturing uses all RoHS-compliant components.

---

---

**NOTES:**



# MICROCHIP

## Worldwide Sales and Service

### AMERICAS

**Corporate Office**  
2355 West Chandler Blvd.  
Chandler, AZ 85224-6199  
Tel: 480-792-7200  
Fax: 480-792-7277  
Technical Support:  
<http://www.microchip.com/support>  
Web Address:  
[www.microchip.com](http://www.microchip.com)

**Atlanta**  
Duluth, GA  
Tel: 678-957-9614  
Fax: 678-957-1455

**Boston**  
Westborough, MA  
Tel: 774-760-0087  
Fax: 774-760-0088

**Chicago**  
Itasca, IL  
Tel: 630-285-0071  
Fax: 630-285-0075

**Cleveland**  
Independence, OH  
Tel: 216-447-0464  
Fax: 216-447-0643

**Dallas**  
Addison, TX  
Tel: 972-818-7423  
Fax: 972-818-2924

**Detroit**  
Farmington Hills, MI  
Tel: 248-538-2250  
Fax: 248-538-2260

**Indianapolis**  
Noblesville, IN  
Tel: 317-773-8323  
Fax: 317-773-5453

**Los Angeles**  
Mission Viejo, CA  
Tel: 949-462-9523  
Fax: 949-462-9608

**Santa Clara**  
Santa Clara, CA  
Tel: 408-961-6444  
Fax: 408-961-6445

**Toronto**  
Mississauga, Ontario,  
Canada  
Tel: 905-673-0699  
Fax: 905-673-6509

### ASIA/PACIFIC

**Asia Pacific Office**  
Suites 3707-14, 37th Floor  
Tower 6, The Gateway  
Harbour City, Kowloon  
Hong Kong  
Tel: 852-2401-1200  
Fax: 852-2401-3431

**Australia - Sydney**  
Tel: 61-2-9868-6733  
Fax: 61-2-9868-6755

**China - Beijing**  
Tel: 86-10-8569-7000  
Fax: 86-10-8528-2104

**China - Chengdu**  
Tel: 86-28-8665-5511  
Fax: 86-28-8665-7889

**China - Chongqing**  
Tel: 86-23-8980-9588  
Fax: 86-23-8980-9500

**China - Hangzhou**  
Tel: 86-571-2819-3187  
Fax: 86-571-2819-3189

**China - Hong Kong SAR**  
Tel: 852-2401-1200  
Fax: 852-2401-3431

**China - Nanjing**  
Tel: 86-25-8473-2460  
Fax: 86-25-8473-2470

**China - Qingdao**  
Tel: 86-532-8502-7355  
Fax: 86-532-8502-7205

**China - Shanghai**  
Tel: 86-21-5407-5533  
Fax: 86-21-5407-5066

**China - Shenyang**  
Tel: 86-24-2334-2829  
Fax: 86-24-2334-2393

**China - Shenzhen**  
Tel: 86-755-8203-2660  
Fax: 86-755-8203-1760

**China - Wuhan**  
Tel: 86-27-5980-5300  
Fax: 86-27-5980-5118

**China - Xian**  
Tel: 86-29-8833-7252  
Fax: 86-29-8833-7256

**China - Xiamen**  
Tel: 86-592-2388138  
Fax: 86-592-2388130

**China - Zhuhai**  
Tel: 86-756-3210040  
Fax: 86-756-3210049

### ASIA/PACIFIC

**India - Bangalore**  
Tel: 91-80-3090-4444  
Fax: 91-80-3090-4123

**India - New Delhi**  
Tel: 91-11-4160-8631  
Fax: 91-11-4160-8632

**India - Pune**  
Tel: 91-20-2566-1512  
Fax: 91-20-2566-1513

**Japan - Osaka**  
Tel: 81-66-152-7160  
Fax: 81-66-152-9310

**Japan - Yokohama**  
Tel: 81-45-471-6166  
Fax: 81-45-471-6122

**Korea - Daegu**  
Tel: 82-53-744-4301  
Fax: 82-53-744-4302

**Korea - Seoul**  
Tel: 82-2-554-7200  
Fax: 82-2-558-5932 or  
82-2-558-5934

**Malaysia - Kuala Lumpur**  
Tel: 60-3-6201-9857  
Fax: 60-3-6201-9859

**Malaysia - Penang**  
Tel: 60-4-227-8870  
Fax: 60-4-227-4068

**Philippines - Manila**  
Tel: 63-2-634-9065  
Fax: 63-2-634-9069

**Singapore**  
Tel: 65-6334-8870  
Fax: 65-6334-8850

**Taiwan - Hsin Chu**  
Tel: 886-3-5778-366  
Fax: 886-3-5770-955

**Taiwan - Kaohsiung**  
Tel: 886-7-536-4818  
Fax: 886-7-330-9305

**Taiwan - Taipei**  
Tel: 886-2-2500-6610  
Fax: 886-2-2508-0102

**Thailand - Bangkok**  
Tel: 66-2-694-1351  
Fax: 66-2-694-1350

### EUROPE

**Austria - Wels**  
Tel: 43-7242-2244-39  
Fax: 43-7242-2244-393

**Denmark - Copenhagen**  
Tel: 45-4450-2828  
Fax: 45-4485-2829

**France - Paris**  
Tel: 33-1-69-53-63-20  
Fax: 33-1-69-30-90-79

**Germany - Munich**  
Tel: 49-89-627-144-0  
Fax: 49-89-627-144-44

**Italy - Milan**  
Tel: 39-0331-742611  
Fax: 39-0331-466781

**Netherlands - Drunen**  
Tel: 31-416-690399  
Fax: 31-416-690340

**Spain - Madrid**  
Tel: 34-91-708-08-90  
Fax: 34-91-708-08-91

**UK - Wokingham**  
Tel: 44-118-921-5869  
Fax: 44-118-921-5820

11/29/11