

PRESSURE SENSOR SIGNAL CONDITIONING INTERFACE

Check for Samples: [TPIC83000-Q1](#)

FEATURES

- Qualified for Automotive Applications
- 10-Bit Pressure and Temperature Output
- On-Board Temperature Sensor
- Programmable Gain / Gain TC1
- Programmable Offset / Offset TC1 / TC2
- On-Board EEPROM for System Calibration
- Operating Temperature Range: -40°C to 85°C
- 16-Pin TSSOP (PW) Package
- UART Interface

APPLICATIONS

- Occupancy Weight Sensing
- Pedal-Pressure Sensing
- General Low-Pressure Sensing

DESCRIPTION

The TPIC83000 is a single-channel, signal conditioning device for pressure sensors used in low-pressure sensing applications such as passenger occupancy indication/detection and pedal pressure sensing. The pressure sensor can be based on either a strain gauge or piezo-resistive elements configured as a full Wheatstone bridge. This device provides an analog signal conditioning interface between the pressure sensor and a microcontroller. The analog front end (AFE) inside the device processes the sensed signals from the pressure sensor by amplifying the signal and cancelling offset. This processed signal is then converted into a 14-bit, digital word using a sigma-delta analog-to-digital converter (ADC). The device also has a built-in 12-bit ADC that is used to sense ambient temperature to compensate for the temperature coefficient of the sensor and related processing circuitry. The compensated digital data is transferred to the microprocessor via a built-in UART interface.

PW PACKAGE
(TOP VIEW)

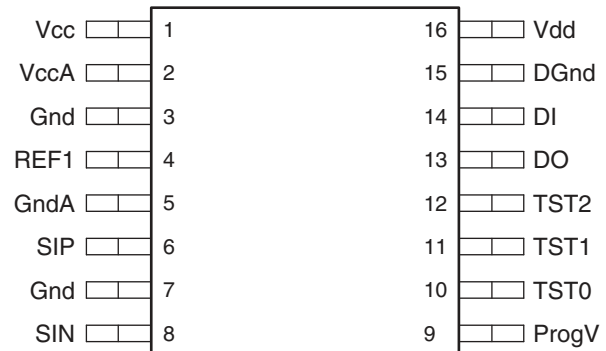

ORDERING INFORMATION⁽¹⁾

T_A	PACKAGE ⁽²⁾		ORDERABLE PART NUMBER	TOP-SIDE MARKING
-40°C to 85°C	TSSOP – PW	Reel of 2000	TPIC83000IPWRQ1	TPIC83000I

- (1) For the most current package and ordering information, see the Package Option Addendum at the end of this document, or see the TI web site at www.ti.com.
- (2) Package drawings, thermal data, and symbolization are available at www.ti.com/packaging.



Please be aware that an important notice concerning availability, standard warranty, and use in critical applications of Texas Instruments semiconductor products and disclaimers thereto appears at the end of this data sheet.

Functional Block Diagram

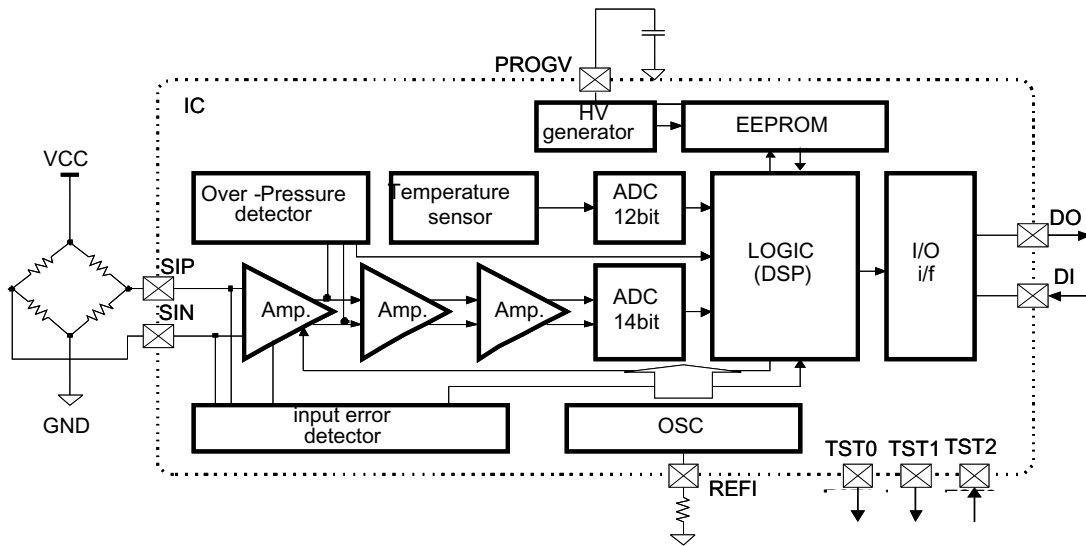

TERMINAL FUNCTIONS

NAME	NO.	TYPE ⁽¹⁾	DESCRIPTION
Vcc	1	I	5-V input analog supply
VccA	2	I	ADC positive reference
Gnd	3	I	Ground (analog)
REFI	4	I	Current reference (V_{bg} / R)
GndA	5	I	ADC negative reference
SIP	6	I / PD	Positive sensor input
Gnd	7	I	Ground (analog)
SIN	8	I / PD	Negative sensor input
ProgV	9	O / PD	EEPROM programming voltage monitor
TST0 (NC) ⁽²⁾	10	I/O	Test (analog / digital)
TST1 (NC) ⁽²⁾	11	I/O	Test (analog / digital)
TST2 (NC) ⁽²⁾	12	I/O	Test (digital)
DO	13	O	UART interface output
DI	14	I	UART interface input
DGnd	15	I	Digital ground
Vdd	16	I	5-V digital supply

(1) I = input, O = output, PD = pulldown, PU = pullup

(2) These pins are to be used for TI internal test purposes only and must be "no connection" in the system application. No signal traces should be connected to the NC pins.

FUNCTIONAL DESCRIPTION

The TPIC83000 is designed for detection of low-pressure variations in many automotive applications. This device provides analog interface signal conditioning between a piezo-resistive or strain gauge pressure sensor and a microcontroller. The input amplifiers process the voltage from the sensor and amplify this voltage before feeding it to the 14-bit sigma-delta ADC for signal conditioning. Once the signal is converted into a digital format, this converted value of the analog signal is processed and transmitted to the microcontroller via the UART interface. There is also a 12-bit ADC to sense ambient temperature, which is used to compensate for non-ideality of the sensor and associated circuitry due to temperature.

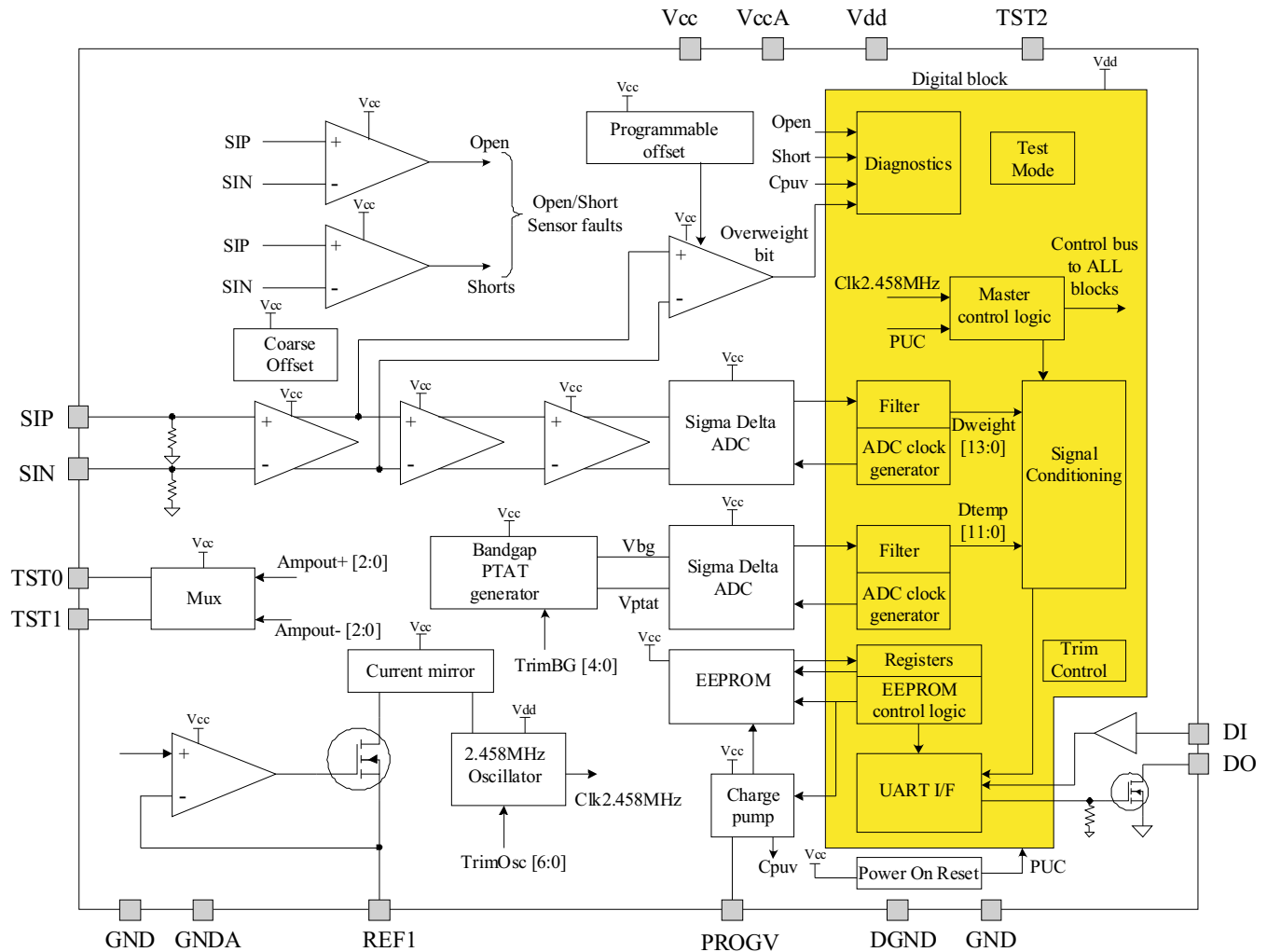

Figure 1. Detailed Functional Block Diagram

Function Pin Description

Supply Voltage (Vcc)

This terminal is the input supply for the analog circuits, typically 5 V +5%/-10% tolerant. A noise filter capacitor of 4.7 μ F (typical) is required on this terminal to ensure stability of the internal circuits.

Ground (Gnd)

This terminal is connected to the system ground.

Ground (DGnd)

This terminal is connected to the system ground.

ADC Reference Voltage (VccA)

This terminal is the input reference for the ADC, typically 5 V. A noise filter capacitor of 0.1 μ F (typical) is required on this terminal to ensure stability of the internal circuits.

Supply Voltage (Vdd)

This terminal is the input supply for the digital circuits, typically 5-V tolerant. A capacitor of 4.7 μ F (typical) is required on this terminal to ensure stability of the internal circuits.

ADC Reference Voltage (GNDA)

This terminal is the input reference for the ADC, typically 0 V.

Gauge OUTPUT (SIP)

The SIP is a positive sensor output. This is the input to the amplifier used for the signal conditioning.

Gauge OUTPUT (SIN)

The SIN is a negative sensor output. This is the input to the amplifier used for the signal conditioning.

Data Input/Data Output (DI/DO)

The DI and DO is the UART communication interface, reporting information back to the microprocessor. This is an open-drain output with the output set to high-impedance mode when other DO in the system is activated. The output is by default in RX mode.

Reference Supply (REFI)

Internally generated reference voltage appears as resistor (10 k Ω) is connected to this pin to set up reference current for internal oscillator.

Internal oscillator frequency $f_{osc} = 2 \times (VBG/R) / (VBG \times C_{trim})$

VBG = Bandgap voltage (VREFI)

Ctrim = Internally trimmed capacitor

EEPROM Supply (PROGV)

This terminal is the supply for EEPROM program. A capacitor of ~1 nF is required on this terminal.

Principles of Operation

The system transfer equation is shown in [Equation 1](#).

$$VDIO_{\text{digital}} = (V_{\text{input}} - VOS - (TCVOS2 \times \text{Temp}) - (TCVOS1 \times \text{Temp}^2)) \times \frac{\text{Gain} \times (1 + (TC_{\text{Gain1}} \times \text{Temp}))}{V_{\text{ccA}} \times 1024} \quad (1)$$

Where

V_{input} = Voltage input to the Logic (DSP) block. This voltage is the same as the output of the Analog Front End

$VDIO_{\text{digital}}$ = Digital output of the logic (DSP) block

Temp = Difference between ambient temperature and room temperature

VOS = Offset adjust

TCVOS1 = Offset TC1 adjust

TCVOS2 = Offset TC2 adjust

Gain = Gain

TCGain1 = Gain TC1 adjust

VccA = ADC reference

$VDIO_{\text{digital}} = 0$ for lower clamp ($T_A = -40^\circ\text{C}$ to 85°C)

$VDIO_{\text{digital}} = 1023$ for upper clamp ($T_A = -40^\circ\text{C}$ to 85°C)

The range and resolution of the parameters is given in [Table 1](#).

Table 1. Output Parameters

ITEM	SYMBOL	BIT NO.	ADJUSTMENT RANGE	DEFAULT	DECIMAL VALUE	BINARY VALUE	ADJUSTMENT VALUE
Input coarse offset	TRVOSC	9	± 120 mV	0 mV	511	11111111	+120 mV
					256	10000000	0 mV
					0	0	-120 mV
Input fine offset	TRVOSF	8	0 to 4×510 μV	0 μV	255	11111111	4×510 μV
					0	0	0
Input offset first-order temperature coefficient	TRTCVOS1	7	$(\pm 25$ $\mu\text{V}/^\circ\text{C}) \times 3$	0 $\mu\text{V}/^\circ\text{C}$	63	1111111	$(+25$ $\mu\text{V}/^\circ\text{C}) \times 3$
					0	0	0
					-64	10000000	$(-25$ $\mu\text{V}/^\circ\text{C}) \times 3$
Input offset second-order temperature coefficient	TRTCVOS2	7	± 40 $\text{nV}/^\circ\text{C}^2$	0 $\mu\text{V}/^\circ\text{C}^2$	63	1111111	40 $\text{nV}/^\circ\text{C}^2$
					0	0	0
					-64	10000000	-40 $\text{nV}/^\circ\text{C}^2$
Gain	TRGAIN	9	100 + 25%	100%	255	1111111	125%
					0	0	100%
					-255	10000000	75%
Gain first-order temperature coefficient	TRTCGAIN1	6	-900 to 0 $\text{ppm}/^\circ\text{C}$	0 $\text{ppm}/^\circ\text{C}$	0	0	0 $\text{ppm}/^\circ\text{C}$
					-63	1	-900 $\text{ppm}/^\circ\text{C}$

DETAILED FUNCTIONAL DESCRIPTION

Pre-Amplifier (Front End)

Due to initial large offset in the pressure sensor output, the analog front end has an offset correction as needed.

Fault Detection

Sensor inputs SIP, SIN

The following faults are detected and a fault bit set in a register. The minimum fault detection filter time is 5 ms. There are 1- μ A pulldown current source on the SIP and SIN terminals. Fault detection capabilities of this device are for both SIP and SIN sensor inputs. The following type of faults are reported and sent to the DIAG bits.

- Shorts to Vcc
- Shorts to Gnd
- Open piezo-resistive or strain gauge (i.e., open-circuit between SIP and SIN inputs)

ADC

The ADC is a 14-bit with resolution of ± 3 LSB (10 bit).

Digital I/O

- I/O data transfer via DI/DO pins.
- Refer to data format communications between microprocessor to IC: Mode selection (microprocessor \rightarrow IC) chart.
- DI/DO interface become active only when specified data format and protocol are used.
- Start bit is used to initiate the communication: DI/DO repeats Rx-Tx-Rx-Tx, to realize one pin Tx-Rx communication. When sensor, temperature, diagnostics, and trimming data are requested, DI/DO remain in Rx mode until all frames are sent.
- DI/DO output current capability is 5 mA at low level.

Memory

- EEPROM : Read/Write cycle is less than 25 times
- Data retention: 15 years at 90°C
- Data fault detection (CRC8)
- Fault write/erase prevention

EEROM Write

- Generate programming voltage after receiving the write RQ.
- Output Diag during the write
- EEROM write sequence
 1. Send data to appropriate bank or field
 2. Send WE = 1
 - (a) Calculate new CRC
 - (b) Set charge pump on
 - (c) Reload all registers from EEPROM
 - (d) Check CRC value
 3. Read Diag register to confirm PROG_OK = 1
 4. Send WE = 0 (≥ 15 ms must elapse for write sequence to complete before microprocessor can disable EEPROM write)

System Configuration/Programming

See the "Baud Rate Settings" table ([Table 21](#)).

Programming Voltage

- Internally generated programming voltage
- Only active during the write mode
- The programming voltage can be monitored at PROG pin.
- 15-ms sec timer / internal undervoltage comparator to guarantee required programming time and voltage level. (12.5 V, 15 ms + system response time > 20 ms)

Temperature Sensor

- Output data linearly proportional to temperature.

Internal Oscillator

- 2.458 MHz
- External resistor is used for current reference
- 10 k Ω

Sensor Output

- Input signal from sensor is analog/digitally processed and output 10-bit word via DIO
- Linear region: output is linear to the sensor input. Clamp region: output is at the clamp value.
- Output and DIAG data can be requested every 100 ms.
- Refer to Data format communications between microprocessor to IC Mode selection (microprocessor → IC) chart.

Data Transfer Format

See [Table 16](#).

Data Output Request (Sensor vs Calibration Mode)

Sensor Mode

1. Receive sensor position ID
2. Output pressure or temperature + DIAG + MODE information

Calibration Mode

A data access mode can be selected by setting ACSUNT

Bank Mode (ACSUNT = 1)

1. Receive sensor position ID + command
2. Receive Bank address
3. Available output is: 1. Sensor output + diagnostics, 2. Temperature, 3. ADC output, 4. Configuration baud rate, 5. Sensor ID + Position ID, 6. Over-pressure setting, 7. Calibration setting, 8 Temperature data, 9. Over-pressure setting history, 10. Calibration history, 11. Mode data

Field Mode (ACSUNT = 0)

1. Receive sensor position ID + Command
2. Receive Field address
3. Available output is: 1. Sensor + diagnostics, 2. Temperature, 3. ADC output, 4. Mode data

Programmable Input Over-Level Detection

Table 2. Input Over-Level Detection Ranges

PARAMETER	MIN	MAX	NOTE
Pressure range	-19.94 mV	-6.93 mV	VSIP – VSIN TRHSGAIN = 5
Programmable threshold level	-21.35 mV	-7.43 mV	TRHSGAIN = 4
Deglintch filter time	0.8 ms	3.2 ms	EEPROM programmable
Programmable step size	0.93 mV		EEPROM programmable TRHSGAIN = 4

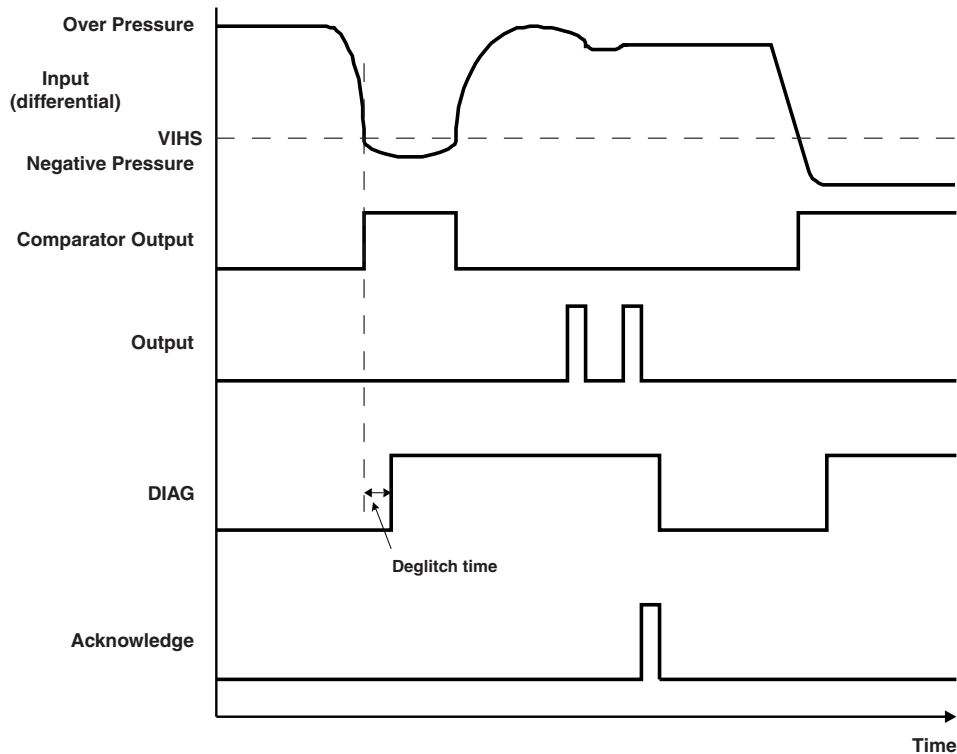

Figure 2. Detection of Negative Pressure Condition

Power Sequence

Power Up

- The IC starts functioning if Vcc is more than UVcc + HVcc (~4 V).
- Power on reset for digital circuit is ~2.5 V.
- EEPROM data loaded to registers
- DO is held low for ~10 ms.

Power Down

- When Vcc is less than UVcc, disable DO.

Glitch on Vcc

- Deglitch time : 320 ns (typical)
- Functionality during the glitch : disable DO
- Functionality after Vcc recovery: same as the Power up. EEPROM data is reloaded to registers if the glitch is lower than 2.5 V (typ).

UART Communication

Communication Protocol

- Protocol: UART
- Transfer Rate: See [Table 21](#)
- Data transfer: See [Table 21](#)
- Internal Oscillator : $38.4k \times 16 \times 4 = 2.458$ MHz
- Data length = 8 bit, Start bit = 1 bit, Stop bit = 1, Parity = even
- Error detection: parity error, over run error, framing error. Ignore the frame when error is detected.
- Time out for "packet not done" is 13 bit. Ignore received data. No response.
- NU: IC to microprocessor is 0. microprocessor to IC 1 or 0.
- Interval Rx-Rx = 2 bit to 13 bit, Rx-Tx = 1.5 bit, Tx-Tx = 2 bit

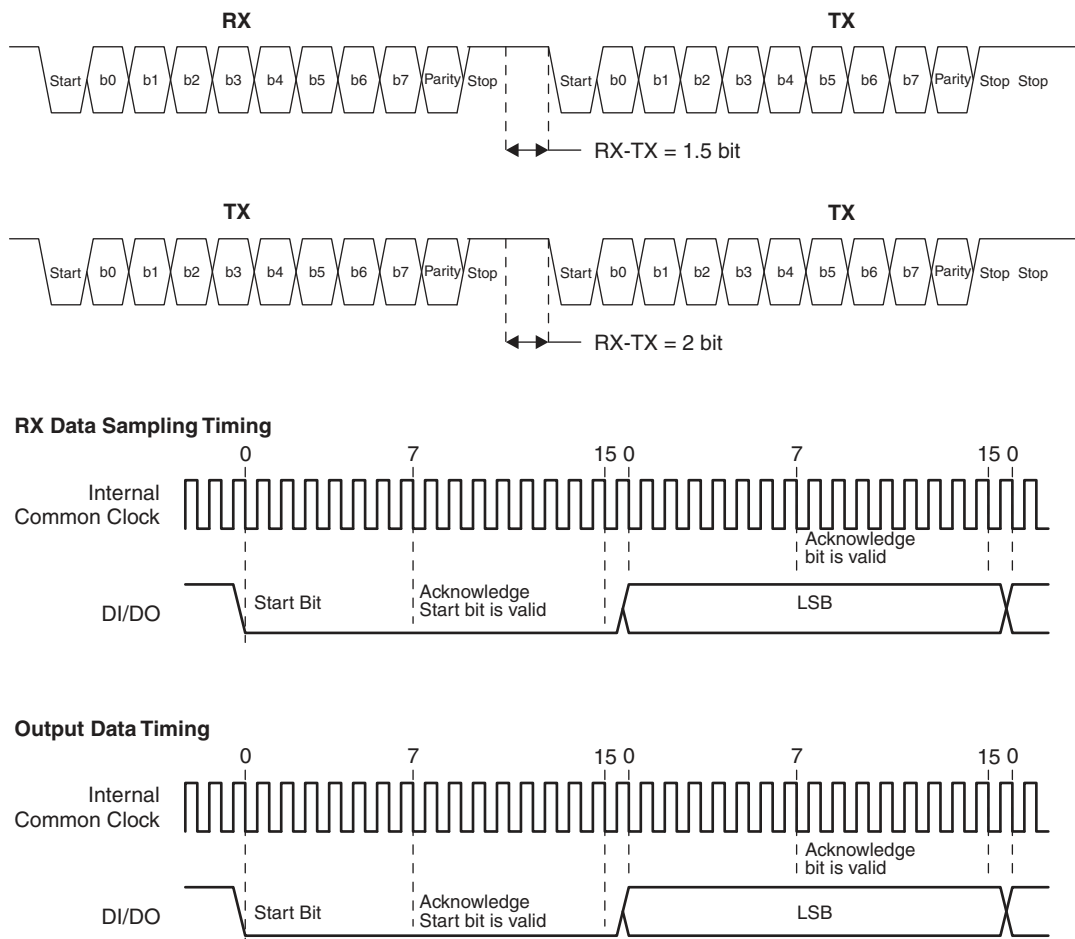

Figure 3. UART Communication Frames, Sampling, and Timing

Device Communication Modes

The TPIC83000 is a pressure sensing conditioning device that interfaces with a microprocessor. The TPIC83000 has register addressing that is partitioned into seven bank mode addresses (labeled 00h to 06h) and 27 field mode addresses (labeled 00h to 1Ah) as shown in [Table 3](#) and [Table 4](#). Bank addresses 00h to 05h are located in the EEPROM, and bank address 06h is located in the logic (DSP) block. Field addresses 00h to 16h are located in the EEPROM, and field addresses 17h to 1Ah are located in the logic (DSP) block. See [Table 3](#) and [Table 4](#) for details.

Table 3. EEPROM Map

BANK MODE ADDRESS	FIELD MODE ADDRESS	DATA FIELD	FIELD NAME	DESCRIPTION	READ/ WRITE	DEFAULT
0000	00000	Sensor ID(43:0)	SENID	Sensor ID	R/W	0
-	00001	PositionID(1:0)	PSNID	Position ID	R/W	0
0001	00010	TRHS(3:0)	TRHS	Over-pressure comparator threshold	R/W	1101
-	00011	TRDELAY(1:0)	TRDELAY	Over-pressure comparator timer	R/W	10
-	00100	TRHSGAIN(2:0)	TRHSGAIN	Over-pressure comparator gain adjust	R/W	0
0010	00101	Config(3:0)	CONFBPS	Baud rate	R/W	10
0011	00110	TRVOS(16:8)	TRVOSC	Input coarse offset	R/W	TRVOSC[16:8] = TEMP2[11:3] ⁽¹⁾
-	00111	TRVOS(7:0)	TRVOSF	Input fine offset	R/W	10000000
-	01000	TC1OFF(6:0)	TRTCVOS1	Input offset first-order temperature coefficient	R/W	0
-	01001	TC2OFF(6:0)	TRTCVOS2	Input offset second-order temperature coefficient	R/W	0
-	01010	GAIN(8:0)	TRGAIN	Gain adjust	R/W	0
-	01011	TCGAIN(5:0)	TRTCGAIN1	Gain first-order temperature coefficient	R/W	100010
0100	01100	TEMPOUT0(11:0)	TEMP0	Temperature sensor data 1	R/W	0
-	01101	TEMPOUT1(11:0)	TEMP1	Temperature sensor data 2	R/W	VPHS
-	01110	TEMPOUT2(11:0)	TEMP2	Temperature sensor data 3	R/W	0
0101	01111	MTRHS(3:0)	MTRHS	History of over-pressure comparator threshold	R	N/A
-	10000	MTR DELAY(1:0)	MTRDELAY	History of over-pressure comparator timer	R	N/A
-	10001	MTRHSGAIN(2:0)	MTRHSGAIN	History of over-pressure comparator gain	R	N/A
-	10010	MTR VOS(16:0)	MTRVOSC	History of input coarse offset	R	N/A
-	10011	MTC1OFF(6:0)	MTRTCVOS1	History of input fine offset	R	N/A
-	10100	MTC2OFF(6:0)	MTRTCVOS2	History of offset first order temperature coefficient	R	N/A
-	10101	MGAIN(8:0)	MTRGAIN	History of offset second order temperature coefficient	R	N/A
-	10110	MTCGAIN(5:0)	MTRTCGAIN1	History of gain first order temperature coefficient	R	N/A

(1) EED-1: All units are shipped with EEPROM values shown in "Default" column.

Table 4. Logic (DSP) Map

BANK MODE ADDRESS	FIELD MODE ADDRESS	DATA FIELD	FIELD NAME	DESCRIPTION	READ/ WRITE	DEFAULT ⁽¹⁾
0110	10111	OUTDATA(9:0)	OUTDATA	Sensor pressure data	R	0
-	11000	OUTTEMP(9:0)	OUTTEMP	Sensor temperature data	R	0
-	11001	ADCDAT(13:0)	ADCDAT	Sensor pressure data from ADC	R	0
-	11010	ADCTMP(11:0)	ADCTMP	Sensor temperature data from ADC	R	0
1000	-		DIAG/UART	Diagnostics and UART	W/R	0

(1) EED-1: All units are shipped with EEPROM values shown in Default column.

The TPIC83000 has two primary modes in which it can be configured to communicate with the microprocessor: Sensor mode and Calibration mode (see [Figure 4](#)). In Sensor mode, the microprocessor requests pressure data from the device that is stored in designated registers of the Logic (DSP) block of the TPIC83000 as well as requests the device to switch from sensor mode to calibration mode. In Calibration mode, the microprocessor can request pressure and temperature data (i.e., Data Request mode), read data from the device (i.e., Calibration Read mode), write data to the device (i.e., Calibration Write mode), as well as allow the IC to switch back to Sensor mode from Calibration mode if desired (i.e., Mode Select mode). The data that is read, written, or requested in Calibration mode is accessed through registers that are located in either the Logic (DSP) or EEPROM.

The Logic (DSP) block and EEPROM of the TPIC83000 have registers that are accessible through addressing schemes. The two (2) addressing schemes that are used in the TPIC83000 are called Bank mode and Field mode addressing. Bank and Field mode addressing are only valid in Calibration mode. Sensor mode is restricted to only sending 10-bit resolution, pressure data to the microprocessor from the Logic (DSP) block. In other words, in Sensor mode, the pressure data comes from the same register in the Logic (DSP) block regardless of whether the device is set for Bank or Field addressing. However, in Calibration mode, the amount of data send via UART bus is dependent on whether the IC is in Bank or Field mode. For example, looking at the EEPROM Map in [Table 3](#), if you wanted to know the position ID configured in the device, you would just access address 00001 in Field Mode. However, if the IC was in Bank Mode, to access this same information, you would have access address 00000 and the microprocessor would simultaneously receive the Sensor ID and Position ID before the next set of instructions is set over the UART bus.

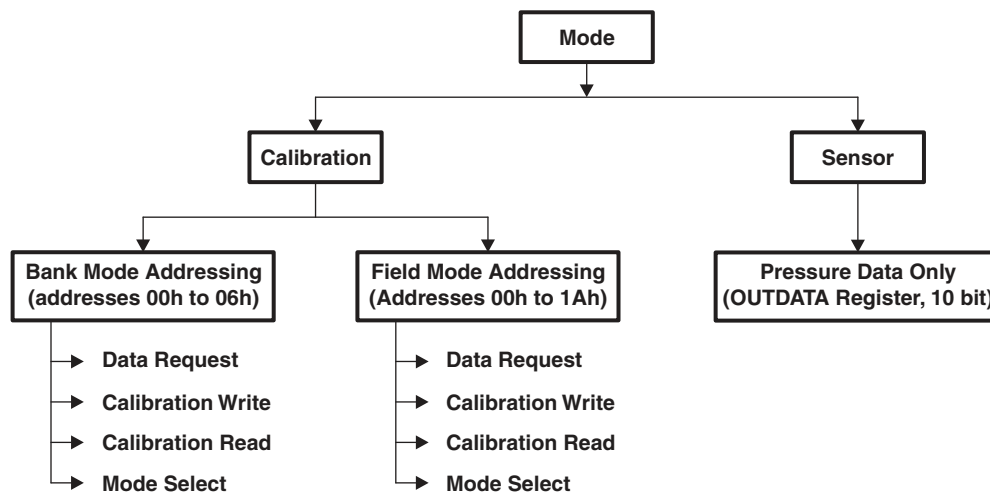

Figure 4. Explanation of Device Modes and Addressing Schemes

Sensor Mode

In the Sensor Mode, the microprocessor sends a command frame to the TPIC83000 in Sensor mode and the TPIC83000 responds with a data frame. Note that in sensor mode, the data frame immediately follows the command frame. The following section explains the command and data frames in detail along with the meaning and action of each bit in these frames.

7	6	5	4	3	2	1	0
PSNID(1)	PSNID(0)	WORDID	ACOVLD	ACOVIN	DISPSN	ACTMODE	ACSUNT
PSNID[1:0]	Bits 7-6	Position ID of device on UART bus. Each device process information for one sensor. Four sensors can be sensed on the UART bus. Position settings are defined in the EEPROM map.					
		00	Position 0				
		01	Position 1				
		10	Position 2				
		11	Position 3				
WORDID	Bit 5	Frame ID of command byte. Sensor mode has only one command frame. Therefore, for sensor mode, always = 0.					
ACOVLD	Bit 4	Acknowledge bit for DIAG1					
		0	Do not reset DIAG1				
		1	Reset DIAG1				
ACOVIN	Bit 3	Acknowledge bit for DIAG0					
		0	Do not reset DIAG0				
		1	Reset DIAG0				
DISPSN	Bit 2	Enable or disable position ID match					
		Recognizes device-specific commands vs global command. Compares position ID of command frame with EEPROM position ID (in device). The command frame position ID is specified in bits 7 and 6 of each frame. The EEPROM position ID is stored in the PSNID field in the EEPROM map.					
		0	Decode command frame only if position IDs match				
		1	Indicates global command. All devices decode command frame.				
ACTMODE	Bit 1	Sets device to sensor or calibration mode after current command is completed.					
		0	Sensor mode				
		1	Calibration mode				
ACSUNT	Bit 0	Sets device to field addressing mode or bank addressing mode. Can be accessed only in calibration mode.					
		0	Bank addressing mode				
		1	Field addressing mode				

Figure 5. Sensor Mode Command Frame Description

7	6	5	4	3	2	1	0
PSNID(1)	PSNID(0)	WORDID	OUTDATA(9)	OUTDATA(8)	OUTDATA(7)	OUTDATA(6)	OUTDATA(5)
ACOVLD	ACOVIN	WORDID	OUTDATA(4)	OUTDATA(3)	OUTDATA(2)	OUTDATA(1)	OUTDATA(0)

First Frame

PSNID[1:0]	Bits 7-6	Position ID of device on UART bus. Each device process information for one sensor. Four sensors can be sensed on the UART bus. Position settings are defined in the EEPROM map. 00 Position 0 01 Position 1 10 Position 2 11 Position 3
WORDID	Bit 5	Frame ID of command byte. Sensor mode has only one command frame. Therefore, for sensor mode, always = 0.
OUTDATA(9:5)	Bits 4-0	Top five MSB of pressure data In sensor mode, data is processed with 10-bit resolution. The data is sent on the UART bus in 5-bit increments until all data is transmitted. For example, if the data is 0100100011, the first five bits sent are 01001 and the second five bits sent are 00011.

Second Frame

ACOVLD	Bit 7	Detection of over-pressure condition and CRC or input voltage error 0 No error detected 1 Error detected
ACOVIN	Bit 6	Detection of CRC or input voltage error across SIP and SIN pins 0 No error detected 1 Error detected
WORDID	Bit 5	Frame ID of command byte. Sensor mode has only one command frame. Therefore, for sensor mode, always = 0.
OUTDATA(4:0)	Bits 4-0	Bottom five bits of pressure data

Figure 6. Sensor Mode Data Frame Description
Table 5. Sensor Mode Command Frame Profile (RX)

DATA NAME	FRAME NO.	B7 (MSB)	B6	B5	B4	B3	B2	B1	B0 (LSB)
TX request	1	PSNID(1)	PSNID(0)	WORD ID	ACOVLD	ACOVIN	DISPSN	ACTMODE	ACSUNT

Table 6. Sensor Mode Data Frame Profile (TX)

DATA NAME	FRAME NO.	B7 (MSB)	B6	B5	B4	B3	B2	B1	B0 (LSB)
Sensor OUT+ DIAG	1	PSNID(1)	PSNID(0)	ACTMODE	OUTDATA(9)	OUTDATA(8)	OUTDATA(7)	OUTDATA(6)	OUTDATA(5)
	2	DIAG(1)	DIAG(0)	ACSUNT	OUTDATA(4)	OUTDATA(3)	OUTDATA(2)	OUTDATA(1)	OUTDATA(0)

Table 7. Bit Descriptions for Sensor Mode Command and Data Frames

CONTROL BIT	VALUE		
DISPSN	0	Position ID matching is enabled and IC respond only when the ID is matched (default)	
	1	Ignore position ID	
ACTMODE (left in Value)	0	Sensor mode(Default)	
	1	Invalid command	
WORD ID (right in Value)	10	Calibration mode	
	11	Invalid command	
ACSUNT	0	Band access (default)	
	1	Field access	
Command ID	00	Data TX request (Default)	
	01	Write Request	
	10	Read request	
	11	Mode selection request	
WE	0	EEPROM Write disabled (Default)	
	1	EEPROM Write Enabled	
DIAG FLAG	NORMAL	FAULT/CLEAR	
DIAG(1)	0	1	Over-pressure fault condition detected (DIAG1 = 1)
DIAG(0)	0	1	CRC or input voltage error fault detected (DIAG0 = 1)
ACOVLD	0	1	Clear DIAG1 bit (ACOVLD = 1)
ACOVIN	0	1	Clear DIAG0 bit (ACOVIN = 1) ⁽¹⁾
POSITION ID	VALUE		
PSNID(1:0)	00	ID:0	Default
	01	ID:1	
	10	ID:2	
	11	ID:3	

(1) If DIAG0 is high (i.e., DIAG0 = 1) because of CRC error, DIAG0 cannot be cleared by ACOVIN.

Table 8. Overview of Self-Diagnostic and UART Errors

Function	DIAG	Register item	Default	Condition	Clear
Self diagnostics	DIAG1	Over-pressure	0	Over-pressure condition	ACOVLD = 1 or PUC
	DIAG0	CRC Error	0	CRC error exists	WE = 0 or PUC
	DIAG0	Input fault	⁽¹⁾	Input voltage error exists	ACOVIN = 1 or PUC
	—	PROG_OK	0	Programming voltage = 12.5 V, 15 ms	WE = 0
UART error		Frame error	0	Framing error exists	ACVOIN = 1
		Over run error	0	Over run error exists	ACVOIN = 1
		Parity error	0	Parity error exists	ACVOIN = 1

(1) DIAG0 may be set to one depending upon Vcc / SIN / SIP power up condition.

Calibration Mode

In calibration mode, microprocessor transmits data to the TPIC83000 in two parts: command frames and data frames. The data frame immediately follows the command frame. However, unlike Sensor mode, a complete instruction in Calibration mode needs two command frames and at least two data frames. Calibration mode consists of four "sub-modes" called Calibration Write, Data Request, Calibration Read, and Mode Select modes. Furthermore, access to information in the EEPROM and Logic (DSP) registers is dependent upon whether the device is in Bank or Field addressing mode. [Table 9](#) summarizes the four Calibration Mode command frames. The following section explains the command and data frames in detail along with the meaning and action of each bit in these frames.

Table 9. Calibration Mode Profile of Command Frames^{(1) (2) (3) (4) (5)}

Microprocessor→IC	FRAME NO.	PSNID		FLAG	MODE TYPE		POSITION ID IGNORE	DIAG ACKNOWLEDGE	
		B7 (MSB)	B6	B5	B4	B3	B2	B1	B0 (LSB)
Data Request	1	PSNID(1)	PSNID(0)	1	0	0	DISPSN	ACVOLD	ACVOIN
	2	PSNID(1)	PSNID(0)	0	NU	RQADCTMP	RQADCDAT	RQTEMP	RQDATA
Calibration Read	1	PSNID(1)	PSNID(0)	1	1	0	DISPSN	NU	NU
	2	PSNID(1)	PSNID(0)	0	Address (5 bit)				
Calibration Mode Select	1	PSNID(1)	PSNID(0)	1	1	1	DISPSN	NU	NU
	2	PSNID(1)	PSNID(0)	0	NU	NU	ACSUNT ⁽⁶⁾	ACTMODE ⁽⁶⁾	WE
Calibration Write	1	PSNID(1)	PSNID(0)	1	0	1	DISPSN	NU	NU
	2	PSNID(1)	PSNID(0)	0	Address (5 bit)				

(1) The request should be ignored when invalid address is received

(2) Baud rate should be updated after all data is received

(3) For mode selection request, if WE = 1 and (ACSUNT and ACTMODE) = "old value", there is no response from IC. Otherwise IC respond with "old ACSUNT and ACTMODE and WE" data then change mode and/or set WE = 1.

(4) RQADCTMP: Request 12-bit temperature data

RQADCDAT: Request 14-bit pressure data

RQTEMP: Request 10-bit temperature data

RQDATA: Request 10-bit pressure data

(5) NU = not used

(6) All modes should be updated after all data is received.

The command frame profiles are the same in both field and bank addressing modes.

Calibration Mode - Data Request

Data Request Command Frames

7	6	5	4	3	2	1	0
PSNID(1)	PSNID(0)	WORDID	MODETYPE		DISPSN	ACOVLD	ACOVIN
PSNID(1)	PSNID(0)	WORDID	NU	RQADCTMP	RQADCDAT	RQTEMP	RQDATA

First Frame

PSNID[1:0]	Bits 7-6	Position ID of device on UART bus. Each device process information for one sensor. Four sensors can be sensed on the UART bus. Position settings are defined in the EEPROM map. 00 Position 0 01 Position 1 10 Position 2 11 Position 3
WORDID	Bit 5	Frame ID of byte. 1 indicates frame 1 of 2.
MODETYPE	Bits 4-3	Select mode type within calibration mode 00 Data request 01 Calibration write 10 Calibration read 11 Mode select
DISPSN	Bit 2	Disable or enable position ID matching 0 Decode command only if position IDs match 1 Indicates global command. All devices decode command frame.
ACOVLD	Bit 1	Acknowledge bit for DIAG1. Can be set to 1 only in Data Request mode (when bits 4:3 are 00). Must be set to 0 for the other mode types. 0 Do not reset DIAG1 1 Reset DIAG1
ACOVIN	Bit 0	Acknowledge bit for DIAG0. Can be set to 1 only in Data Request mode (when bits 4:3 are 00). Must be set to 0 for the other mode types. 0 Do not reset DIAG0 1 Reset DIAG0

Second Frame

PSNID[1:0]	Bits 7-6	Position ID of device on UART bus. Each device process information for one sensor. Four sensors can be sensed on the UART bus. Position settings are defined in the EEPROM map. 00 Position 0 01 Position 1 10 Position 2 11 Position 3
WORDID	Bit 5	Frame ID of byte. 0 indicates frame 2 of 2.
NU	Bit 4	Not used. Set to 0.
RQADCTMP	Bit 3	Microcontroller request for 12-bit temperature data from device. 0 Do not send data in following data frames 1 Send data in following data frames
RQADCDAT	Bit 2	Microcontroller request for 14-bit pressure data from device. 0 Do not send data in following data frames 1 Send data in following data frames
RQTEMP	Bit 1	Microcontroller request for 10-bit temperature data from device. 0 Do not send data in following data frames 1 Send data in following data frames
RQDATA	Bit 0	Microcontroller request for 10-bit pressure data from device. 0 Do not send data in following data frames 1 Send data in following data frames

Figure 7. Data Request Command Frames

Data Request Data Frames

7	6	5	4	3	2	1	0
D13	D12	D11	D10	D9	D8	D7	D6
D5	D4	D3	D2	D1	D0	DIAG1	DIAG0

First Frame

D[13:6] Bits 7-0 Data length ranges from 10 to 14 bits. Data is sent starting with D13, and any unused trailing bits are set to 0. Data requested in the preceding command frame is sent in the order shown below, with the data request of highest priority is sent in the first two data frames, and any lower-priority requests sent in order in following two-frame sets.

Priority	Description
1	Pressure data in 10-bit format
2	Temperature data in 10-bit format
3	Pressure data in 14-bit format
4	Temperature data in 12-bit format

Second Frame

D[5:0] Bits 7-2 See D[13:6] description.
 DIAG1 Bit 1 Over-pressure fault condition
 0 Fault not detected
 1 Fault detected
 DIAG0 Bit 0 CRC or input voltage error fault
 0 Fault not detected
 1 Fault detected

Figure 8. Data Request Data Frames

Table 10. Profile of Data Request Data Frames (Field Mode Addressing)

FIELD NAME (BANK ADDRESS)	FIELD MODE ADDRESS	B7 (MSB)	B6	B5	B4	B3	B2	B1	B0 (LSB)	B1	B0
				DATA 8 BIT)							
Sensor + DIAG	Tx RQ	(9:0) +(1:0)	1	OUT DATA(9)	OUT DATA(8)	OUT DATA(7)	OUT DATA(6)	OUT DATA(5)	OUT DATA(4)	OUT DATA(3)	OUT DATA(2)
	Tx RQ		2	OUT DATA(1)	OUT DATA(0)	NU	NU	NU	NU	DIAG(1)	DIAG(0)
Temperature out	Tx RQ	(9:0)	1	OUT TEMP(9)	OUT TEMP(8)	OUT TEMP(7)	OUT TEMP(6)	OUT TEMP(5)	OUT TEMP(4)	OUT TEMP(3)	OUT TEMP(2)
	Tx RQ		2	OUT TEMP(1)	OUT TEMP(0)	NU	NU	NU	NU	DIAG(1)	DIAG(0)
ADC pressure out	Tx RQ	(13:0)	1	ADCDAT(13)	ADCDAT(12)	ADCDAT(11)	ADCDAT(10)	ADCDAT(9)	ADCDAT(8)	ADCDAT(7)	ADCDAT
	Tx RQ		2	ADCDAT(5)	ADCDAT(4)	ADCDAT(3)	ADCDAT(2)	ADCDAT(1)	ADCDAT(0)	DIAG(1)	DIAG(0)
ADC temperature out	Tx RQ	(11:0)	1	ADC TMP(11)	ADC TMP(10)	ADCTMP(9)	ADCTMP(8)	ADCTMP(7)	ADCTMP(6)	ADCTMP(5)	ADCTMP(4)
	Tx RQ		2	ADCTMP(3)	ADCTMP(2)	ADCTMP(1)	ADCTMP(0)	NU	NU	DIAG(1)	DIAG(0)

Table 11. Profile of Data Request Data Frames (Bank Mode Addressing)

FIELD NAME (BANK ADDRESS)	FIELD MODE ADDRESS	LENGTH	FRAME NO.	B7 (MSB)	B6	B5	B4	B3	B2	B1	B0 (LSB)
				DATA							
Sensor OUT + Diag	TX RQ	(9:0) +(1:0)	1	OUT DATA(9)	OUT DATA(8)	OUT DATA(7)	OUT DATA(6)	OUT DATA(5)	OUT DATA(4)	OUT DATA(3)	OUT DATA(2)
	TX RQ		2	OUT DATA(1)	OUT DATA(0)	NU	NU	NU	NU	DIAG(1)	DIAG(0)
Temperature out	TX RQ	(9:0)	1	OUT TEMP(9)	OUT TEMP(8)	OUT TEMP(7)	OUT TEMP(6)	OUT TEMP(5)	OUT TEMP(4)	OUT TEMP(3)	OUT TEMP(2)
	TX RQ		2	OUT TEMP(1)	OUT TEMP(0)	NU	NU	NU	NU	DIAG(1)	DIAG(0)
ADC pressure out	TX RQ	(13:0)	1	ADCDAT(13)	ADCDAT(12)	ADCDAT(11)	ADCDAT(10)	ADCDAT(9)	ADCDAT(8)	ADCDAT(7)	ADCDAT(6)
	TX RQ		2	ADCDAT(5)	ADCDAT(4)	ADCDAT(3)	ADCDAT(2)	ADCDAT(1)	ADCDAT(0)	DIAG(1)	DIAG(0)

Table 11. Profile of Data Request Data Frames (Bank Mode Addressing) (continued)

FIELD NAME (BANK ADDRESS)	FIELD MODE ADDRESS	LENGTH	FRAME NO.	B7 (MSB)	B6	B5	B4	B3	B2	B1	B0 (LSB)
				DATA							
ADC temperature out	TX RQ	(11:0)	1	ADC TMP(11)	ADC TMP(10)	ADC TMP(9)	ADC TMP(8)	ADC TMP(7)	ADC TMP(6)	ADC TMP(5)	ADC TMP(4)
	TX RQ		2	ADC TMP(3)	ADC TMP(2)	ADC TMP(1)	ADC TMP(0)	NU	NU	DIAG(1)	DIAG(0)

Calibration Mode – Data Write
Calibration Write Command Frames

7	6	5	4	3	2	1	0
PSNID(1)	PSNID(0)	WORDID	MODETYPE		DISPSN	0	0
PSNID(1)	PSNID(0)	WORDID	ADDR4	ADDR3	ADDR2	ADDR1	ADDR0

First Frame

PSNID[1:0]	Bits 7-6	Position ID of device on UART bus. Each device process information for one sensor. Four sensors can be sensed on the UART bus. Position settings are defined in the EEPROM map. 00 Position 0 01 Position 1 10 Position 2 11 Position 3
WORDID	Bit 5	Frame ID of byte. 1 indicates frame 1 of 2.
MODETYPE	Bits 4-3	Select mode type within calibration mode 00 Data request 01 Calibration write 10 Calibration read 11 Mode select
DISPSN	Bit 2	Disable or enable position ID matching 0 Decode command only if position IDs match 1 Indicates global command. All devices decode command frame.
Reserved	Bits 1-0	Must be set to 0.

Second Frame

PSNID[1:0]	Bits 7-6	Position ID of device on UART bus. Each device process information for one sensor. Four sensors can be sensed on the UART bus. Position settings are defined in the EEPROM map. 00 Position 0 01 Position 1 10 Position 2 11 Position 3
WORDID	Bit 5	Frame ID of byte. 0 indicates frame 2 of 2.
ADDR[4:0]	Bits 4-0	Address for bank or field mode addressing. See Table 3 for list of valid addresses.

Figure 9. Calibration Write Command Frames

Calibration Write Data Frames

	7	6	5	4	3	2	1	0
	PSNID(1)	PSNID(0)	NU	D43	D42	D41	D40	D39
	⋮							
	PSNID(1)	PSNID(0)	NU	D3	D2	D1	D0	0

Frames 3 through (n – 1) (where n = 5 to 11)

- PSNID[1:0] Bits 7-6 Position ID of device on UART bus. Each device process information for one sensor. Four sensors can be sensed on the UART bus. Position settings are defined in the EEPROM map.
 - 00 Position 0
 - 01 Position 1
 - 10 Position 2
 - 11 Position 3
- NU Bit 5 Not used. Set to 0.
- Dx Bits 4-0 Top five bits of bank or field data. See [Table 3](#) and [Table 4](#) for valid addresses and types of data.

Frame n (where n = 4 to 11)

- PSNID[1:0] Bits 7-6 Position ID of device on UART bus. Each device process information for one sensor. Four sensors can be sensed on the UART bus. Position settings are defined in the EEPROM map.
 - 00 Position 0
 - 01 Position 1
 - 10 Position 2
 - 11 Position 3
- NU Bit 5 Not used. Set to 0.
- Dx Bits 4-0 Next or last five bits of bank or field data. See [Table 3](#) and [Table 4](#) for valid addresses and types of data. Data length for each calibration write frame is 5 bits. Maximum number of frames that can be written from one command is nine; therefore, maximum data length is 44 bits.

Figure 10. Calibration Write Data Frames

Table 12. Profile of Calibration Write Data Frames (Field Addressing Mode)

DATA NAME	FRAME NO.	B7 (MSB)	B6	B5	B4	B3	B2	B1	B0 (LSB)
Data	3	PSNID(1)	PSNID(0)	0	Data (5 bit)				
Sensor ID	3	PSNID(1)	PSNID(0)	0	SENID(43)	SENID(42)	SENID(41)	SENID(40)	SENID(39)
	4				SENID(38)	SENID(37)	SENID(36)	SENID(35)	SENID(34)
	5				SENID(33)	SENID(32)	SENID(31)	SENID(30)	SENID(29)
	6				SENID(28)	SENID(27)	SENID(26)	SENID(25)	SENID(24)
	7				SENID(23)	SENID(22)	SENID(21)	SENID(20)	SENID(19)
	8				SENID(18)	SENID(17)	SENID(16)	SENID(15)	SENID(14)
	9				SENID(13)	SENID(12)	SENID(11)	SENID(10)	SENID(9)
	10				SENID(8)	SENID(7)	SENID(6)	SENID(5)	SENID(4)
	11				SENID(3)	SENID(2)	SENID(1)	SENID(0)	NU
Position ID	3				PSNID(1)	PSNID(0)	NU	NU	NU
OP threshold	3				TRHS(3)	TRHS(2)	TRHS(1)	TRHS(0)	NU
OP timer	3				TRDELAY(1)	TRDELAY(0)	NU	NU	NU
OP gain	3				TRHSGAIN(2)	TRHSGAIN(1)	TRHSGAIN(0)	NU	NU
Baud rate	3				CONF BPS(3)	CONF BPS(2)	CONF BPS(1)	CONF BPS(0)	NU
Input coarse offset	3				TRV OSC(16)	TRV OSC(15)	TRV OSC(14)	TRV OSC(13)	TRV OSC(12)
	4				TRV OSC(11)	TRV OSC(10)	TRV OSC(9)	TRV OSC(8)	NU
Input fine offset	3				TRVOSF(7)	TRVOSF(6)	TRVOSF(5)	TRVOSF(4)	TRVOSF(3)
	4	PSNID(1)	PSNID(0)	0	TRVOSF(2)	TRVOSF(1)	TRVOSF(0)	NU	NU
Input offset first order temperature coefficient	3				TRTC VOS1(6)	TRTC VOS1(5)	TRTC VOS1(4)	TRTC VOS1(3)	TRTC VOS1(2)
	4				TRTC VOS1(1)	TRTC VOS1(0)	NU	NU	NU
Input offset second order temperature coefficient	3				TRTC VOS2(6)	TRTC VOS2(5)	TRTC VOS2(4)	TRTC VOS2(3)	TRTC VOS2(2)
	4				TRTC VOS2(1)	TRTC VOS2(0)	NU	NU	NU
GAIN adjust	3				TRGAIN(8)	TRGAIN(7)	TRGAIN(6)	TRGAIN(5)	TRGAIN(4)
	4				TRGAIN(3)	TRGAIN(2)	TRGAIN(1)	TRGAIN(0)	NU
Gain first order temperature coefficient	3				TRTC GAIN1(5)	TRTC GAIN1(4)	TRTC GAIN1(3)	TRTC GAIN1(2)	TRTC GAIN1(1)
	4				TRTC GAIN1(0)	NU	NU	NU	NU
Temperature sensor out 1	3				TEMP0(11)	TEMP0(10)	TEMP0(9)	TEMP0(8)	TEMP0(7)
	4				TEMP0(6)	TEMP0(5)	TEMP0(4)	TEMP0(3)	TEMP0(2)
	5				TEMP0(1)	TEMP0(0)	NU	NU	NU
Temperature sensor out 2	3				TEMP1(11)	TEMP1(10)	TEMP1(9)	TEMP1(8)	TEMP1(7)
	4				TEMP1(6)	TEMP1(5)	TEMP1(4)	TEMP1(3)	TEMP1(2)
	5				TEMP1(1)	TEMP1(0)	NU	NU	NU
Temperature sensor out 3	3				TEMP2(11)	TEMP2(10)	TEMP2(9)	TEMP2(8)	TEMP2(7)
	4				TEMP2(6)	TEMP2(5)	TEMP2(4)	TEMP2(3)	TEMP2(2)
	5				TEMP2(1)	TEMP2(0)	NU	NU	NU

Table 13. Profile of Calibration Write Data Frames (Bank Addressing Mode)

DATA NAME	FRAME NO.	B7 (MSB)	B6	B5	B4	B3	B2	B1	B0 (LSB)
Data (Bank Address)	3	PSNID(1)	PSNID(0)	0	data 5bit				
Sensor ID (0)	3	PSNID(1)	PSNID(0)	0	SENID(43)	SENID(42)	SENID(41)	SENID(40)	SENID(39)
	4				SENID(38)	SENID(37)	SENID(36)	SENID(35)	SENID(34)
	5				SENID(33)	SENID(32)	SENID(31)	SENID(30)	SENID(29)
	6				SENID(28)	SENID(27)	SENID(26)	SENID(25)	SENID(24)
	7				SENID(23)	SENID(22)	SENID(21)	SENID(20)	SENID(19)
	8				SENID(18)	SENID(17)	SENID(16)	SENID(15)	SENID(14)
	9				SENID(13)	SENID(12)	SENID(11)	SENID(10)	SENID(9)
	10				SENID(8)	SENID(7)	SENID(6)	SENID(5)	SENID(4)
PSN ID(0)	12				PSNID(1)	PSNID(0)	NU	NU	NU
OP threshold (1)	3	PSNID(1)	PSNID(0)	0	TRHS(3)	TRHS(2)	TRHS(1)	TRHS(0)	NU
OP timer (1)	4				TRDELAY(1)	TRDELAY(0)	NU	NU	NU
OP gain (1)	5				TRHSGAIN(2)	TRHSGAIN(1)	TRHSGAIN(0)	NU	NU
Baud rate (2)	3				CONF BPS(3)	CONF BPS(2)	CONF BPS(1)	CONF BPS(0)	NU
Input coarse offset (3)	3				TRV OSC(16)	TRV OSC(15)	TRV OSC(14)	TRV OSC(13)	TRV OSC(12)
	4				TRV OSC(11)	TRV OSC(10)	TRV OSC(9)	TRV OSC(8)	NU
Input fine offset (3)	5				TRVOSF(7)	TRVOSF(6)	TRVOSF(5)	TRVOSF(4)	TRVOSF(3)
	6				TRVOSF(2)	TRVOSF(1)	TRVOSF(0)	NU	NU
Input offset first order temperature coefficient (3)	7				TRTC VOS1(6)	TRTC VOS1(5)	TRTC VOS1(4)	TRTC VOS1(3)	TRTC VOS1(2)
	8				TRTC VOS1(1)	TRTC VOS1(0)	NU	NU	NU
Input offset second order temperature coefficient (3)	9				TRTC VOS2(6)	TRTC VOS2(5)	TRTC VOS2(4)	TRTC VOS2(3)	TRTC VOS2(2)
	10				TRTC VOS2(1)	TRTC VOS2(0)	NU	NU	NU
Gain adjust (3)	11				TRGAIN(8)	TRGAIN(7)	TRGAIN(6)	TRGAIN(5)	TRGAIN(4)
	12				TRGAIN(3)	TRGAIN(2)	TRGAIN(1)	TRGAIN(0)	NU
Gain first order temperature coefficient (3)	13				TRTC GAIN1(5)	TRTC GAIN1(4)	TRTC GAIN1(3)	TRTC GAIN1(2)	TRTC GAIN1(1)
	14				TRTC GAIN1(0)	NU	NU	NU	NU
Temperature sensor out 1 (4)	3				TEMP0(11)	TEMP0(10)	TEMP0(9)	TEMP0(8)	TEMP0(7)
	4				TEMP0(6)	TEMP0(5)	TEMP0(4)	TEMP0(3)	TEMP0(2)
	5				TEMP0(1)	TEMP0(0)	NU	NU	NU
Temperature sensor out 2 (4)	6				TEMP1(11)	TEMP1(10)	TEMP1(9)	TEMP1(8)	TEMP1(7)
	7				TEMP1(6)	TEMP1(5)	TEMP1(4)	TEMP1(3)	TEMP1(2)
	8				TEMP1(1)	TEMP1(0)	NU	NU	NU
Temperature sensor out 3 (4)	9				TEMP2(11)	TEMP2(10)	TEMP2(9)	TEMP2(8)	TEMP2(7)
	10				TEMP2(6)	TEMP2(5)	TEMP2(4)	TEMP2(3)	TEMP2(2)
	11	TEMP2(1)	TEMP2(0)	NU	NU	NU			
DIAG/UART	3	PSNID(1)	PSNID(0)	0	0	0	0	0	0
	4				0	0	0	0	0
	5				0	0	0	0	Fastdis
	6				Stbit	EO	Pdis	0	0

Table 14. DIAG/UART Register (Bank Address = 8)

ITEM	DESCRIPTION
Pdis	Parity disable 1 = Disable 0 = Enable
EO	Parity even or odd 1 = Odd 0 = Even
Stbit	Stop bit length 1 = 2 bit 0 = 1 bit
Fastdis	Test mode baud rate 1 = Normal 0 = 153 kHz

Table 15. TPIC83000 Response and Mode Update Timing for Calibration Write Mode

ITEM	SYMBOL	RESPONSE	SETTING / MODE UPDATE TIMING
ID / Calibration / Temperature	SENID	NEW VALUE	After IC's response
	PSNID	Current value	WE = 1
	TRHS	New value	After IC's response
	TRDELAY	New value	
	TRHSGAIN	New value	
	CONFBPS	New value	
	TRVOSC	New value	
	TRVOSF	New value	
	TRTCVOS1	New value	
	TRTCVOS2	New value	
	TRGAIN	New value	
	TRTCGAIN1	New value	
	TEMP0	New value	
	TEMP1	New value	
TEMP2	New value		
History	MTRHS	N/A	WE = 1
	MTRDELAY	N/A	
	MTRHSGAIN	N/A	
	MTRVOSC	N/A	
	MTRVOSF	N/A	
	MTRTCVOS1	N/A	
	MTRTCVOS2	N/A	
	MTRGAIN	N/A	
	MTRTCGAIN1	N/A	
Mode / Setting	ACTMODE	Current value	After IC's response (No response for WE = 1)
	ACSUNT	Current value	
	WE	Current value	

Calibration Mode – Calibration Read

Calibration Read Command Frames

7	6	5	4	3	2	1	0
PSNID(1)	PSNID(0)	WORDID	MODETYPE		DISPSN	Reserved	
PSNID(1)	PSNID(0)	WORDID	ADDR4	ADDR3	ADDR2	ADDR1	ADDR0

First Frame

PSNID[1:0]	Bits 7-6	Position ID of device on UART bus. Each device process information for one sensor. Four sensors can be sensed on the UART bus. Position settings are defined in the EEPROM map. 00 Position 0 01 Position 1 10 Position 2 11 Position 3
WORDID	Bit 5	Frame ID of byte. 1 indicates frame 1 of 2.
MODETYPE	Bits 4-3	Select mode type within calibration mode 00 Data request 01 Calibration write 10 Calibration read 11 Mode select
DISPSN	Bit 2	Disable or enable position ID matching 0 Decode command only if position IDs match 1 Indicates global command. All devices decode command frame.
Reserved	Bits 1-0	Must be set to 0.

Second Frame

PSNID[1:0]	Bits 7-6	Position ID of device on UART bus. Each device process information for one sensor. Four sensors can be sensed on the UART bus. Position settings are defined in the EEPROM map. 00 Position 0 01 Position 1 10 Position 2 11 Position 3
WORDID	Bit 5	Frame ID of byte. 0 indicates frame 2 of 2.
ADDR[4:0]	Bits 4-0	Address for bank or field mode addressing. See Table 3 for list of valid addresses.

Figure 11. Calibration Read Command Frames

Table 16. Data Format Actual Values for Data Request Mode

ITEM	SYMBOL	DATA LENGTH	NOTE/CONDITION	BINARY VALUE	DECIMAL VALUE
Pressure data	OUTDATA	10	Input = -2.275 mV, 0 mV, 4.095 mV	11 1111 1111	1023
			Gain = nominal	01 0110 1101	365
				00 0000 0000	0
Pressure ADC data	ADCDAT	14	Input = -2.275 mV, 0 mV, 4.095 mV	00 1111 1011 1010	4026
			Gain = nominal	00 0000 0000 0000	0
				Twos compliment	11 0111 0100 0100
Temperature data	OUTTEMP	10	T _A = 85°C	01 1000 1100	396
			T _A = 25°C	00 0000 0000	0
			T _A = -40°C	10 0101 0011	-429
Temperature ADC data	ADCTMP	12	T _A = 85°C	0110 0011 0001	1585
			T _A = 25°C	0000 0000 0000	0
			T _A = -40°C	1001 0100 1011	-1717

Calibration Read Data Frames

7	6	5	4	3	2	1	0
D43	D42	D41	D40	D39	D38	D37	D36
⋮							
D3	D2	D1	D0	NU	NU	NU	NU

First Frame

Dx Bits 7-0 Microcontroller reads data from the designated address in the device (from EEPROM). See [Table 3](#) for list of valid addresses.

Second through (n – 1) Frame (where n = 2 to 6)

Dx Bits 7-0 Microcontroller reads data from the designated address in the device (from EEPROM). The number of frames sent depends on the size of the data.

Frame n (where n = 2 to 6)

Dx Bits 7-4 Microcontroller reads data from the designated address in the device (from EEPROM).
 NU Bits 3-0 Not used. Set to 0.

Figure 12. Calibration Read Data Frames
Table 17. Profile of Calibration Read Data Frames (Field Mode Addressing)

FIELD NAME (BANK ADDRESS)	FIELD MODE ADDRESS	LENGTH	FRAME NO.	B7 (MSB)	B6	B5	B4	B3	B2	B1	B0 (LSB)
				DATA							
Sensor ID	0000	(43:0)	1	SENID(43)	SENID(42)	SENID(41)	SENID(40)	SENID(39)	SENID(38)	SENID(37)	SENID(36)
			2	SENID(35)	SENID(34)	SENID(33)	SENID(32)	SENID(31)	SENID(30)	SENID(29)	SENID(28)
			3	SENID(27)	SENID(26)	SENID(25)	SENID(24)	SENID(23)	SENID(22)	SENID(21)	SENID(20)
			4	SENID(19)	SENID(18)	SENID(17)	SENID(16)	SENID(15)	SENID(14)	SENID(13)	SENID(12)
			5	SENID(11)	SENID(10)	SENID(9)	SENID(8)	SENID(7)	SENID(6)	SENID(5)	SENID(4)
			6	SENID(3)	SENID(2)	SENID(1)	SENID(0)	NU	NU	NU	NU
Position ID	0001	(1:0)	1	PSNID(1)	PSNID(0)	NU	NU	NU	NU	NU	NU
OP threshold	0010	(3:0)	1	TRHS(3)	TRHS(2)	TRHS(1)	TRHS(0)	NU	NU	NU	NU
OP timer	0011	(1:0)	1	TRDELAY(1)	TRDELAY(0)	NU	NU	NU	NU	NU	NU
OP gain	0100	(2:0)	1	TRHSGAIN(2)	TRHSGAIN(1)	TRHSGAIN(0)	NU	NU	NU	NU	NU
Baud rate	0101	(3:0)	1	CONF BPS(3)	CONF BPS(2)	CONF BPS(1)	CONF BPS(0)	NU	NU	NU	NU
Input Coarse offset	0110	(16:8)	1	TRV OSC(16)	TRV OSC(15)	TRV OSC(14)	TRV OSC(13)	TRV OSC(12)	TRV OSC(11)	TRV OSC(10)	TRV OSC(9)
			2	TRVOSC	NU	NU	NU	NU	NU	NU	NU
Input fine offset	0111	(7:0)	1	TRVOSF(7)	TRVOSF(6)	TRVOSF(5)	TRVOSF(4)	TRVOSF(3)	TRVOSF(2)	TRVOSF(1)	TRVOSF(0)
Input offset first order temperature coefficient	1000	(6:0)	1	TRTC VOS1(6)	TRTCVOS1	TRTC VOS1(4)	TRTC VOS1(3)	TRTC VOS1(2)	TRTC VOS1(1)	TRTC VOS1(0)	NU
Input offset second order temperature coefficient	1001	(6:0)	1	TRTC VOS2(6)	TRTC VOS2(5)	TRTC VOS2(4)	TRTC VOS2(3)	TRTC VOS2(2)	TRTC VOS2(1)	TRTC VOS2(0)	NU
Gain adjust	1010	(8:0)	1	TRGAIN(8)	TRGAIN(7)	TRGAIN(6)	TRGAIN(5)	TRGAIN(4)	TRGAIN(3)	TRGAIN(2)	TRGAIN(1)
			2	TRGAIN(0)	NU	NU	NU	NU	NU	NU	NU
Gain first order temperature coefficient	1011	(5:0)	1	TRTC GAIN1(5)	TRTC GAIN1(4)	TRTC GAIN1(3)	TRTC GAIN1(2)	TRTC GAIN1(1)	TRTC GAIN1(0)	NU	NU
Temperature sensor OUT 1	1100	(11:0)	1	TEMP0(11)	TEMP0(10)	TEMP0(9)	TEMP0(8)	TEMP0(7)	TEMP0(6)	TEMP0(5)	TEMP0(4)
			2	TEMP0(3)	TEMP0(2)	TEMP0(1)	TEMP0(0)	NU	NU	NU	NU
Temperature sensor OUT 2	1101	(11:0)	1	TEMP1(11)	TEMP1(10)	TEMP1(9)	TEMP1(8)	TEMP1(7)	TEMP1(6)	TEMP1(5)	TEMP1(4)
			2	TEMP1(3)	TEMP1(2)	TEMP1(1)	TEMP1(0)	NU	NU	NU	NU
Temperature sensor OUT 3	1110	(11:0)	1	TEMP2(11)	TEMP2(10)	TEMP2(9)	TEMP2(8)	TEMP2(7)	TEMP2(6)	TEMP2(5)	TEMP2(4)
			2	TEMP2(3)	TEMP2(2)	TEMP2(1)	TEMP2(0)	NU	NU	NU	NU
History of OP threshold	1111	(3:0)	1	MTRHS(3)	MTRHS(2)	MTRHS(1)	MTRHS(0)	NU	NU	NU	NU

Table 17. Profile of Calibration Read Data Frames (Field Mode Addressing) (continued)

FIELD NAME (BANK ADDRESS)	FIELD MODE ADDRESS	LENGTH	FRAME NO.	B7 (MSB)	B6	B5	B4	B3	B2	B1	B0 (LSB)
				DATA							
History of OP timer	10000	(1:0)	1	MTR DELAY(1)	MTR DELAY(0)	NU	NU	NU	NU	NU	NU
History OP gain	10001	(2:0)	1	MTRHS GAIN(2)	MTRHS GAIN(1)	MTRHS GAIN(0)	NU	NU	NU	NU	NU
History of Input offset	10010	(17:0)	1	MTR VOS(17)	MTR VOS(16)	MTR VOS(15)	MTR VOS(14)	MTR VOS(13)	MTR VOS(12)	MTR VOS(11)	MTR VOS(10)
			2	MTR VOS(9)	MTR VOS(8)	MTR VOS(7)	MTR VOS(6)	MTR VOS(5)	MTR VOS(4)	MTR VOS(3)	MTR VOS(2)
			3	MTR VOS(1)	MTR VOS(0)	NU	NU	NU	NU	NU	NU
History of Input offset first order temperature coefficient	10011	(6:0)	1	MTRTC VOS1(6)	MTRTC VOS1(5)	MTRTC VOS1(4)	MTRTC VOS1(3)	MTRTC VOS1(2)	MTRTC VOS1(1)	MTRTC VOS1(0)	NU
History of Input offset 2nd order temperature coefficient	10100	(6:0)	1	MTRTC VOS2(6)	MTRTC VOS2(5)	MTRTC VOS2(4)	MTRTC VOS2(3)	MTRTC VOS2(2)	MTRTC VOS2(1)	MTRTC VOS2(0)	NU
History of Gain adjust	10101	(8:0)	1	MTRGAIN(8)	MTRGAIN(7)	MTRGAIN(6)	MTRGAIN(5)	MTRGAIN(4)	MTRGAIN(3)	MTRGAIN(2)	MTRGAIN(1)
			2	MTRGAIN(0)	NU	NU	NU	NU	NU	NU	NU
History of Gain first order temperature coefficient	10110	(5:0)	1	MTRTC GAIN1(5)	MTRTC GAIN1(4)	MTRTC GAIN1(3)	MTRTC GAIN1(2)	MTRTC GAIN1(1)	MTRTC GAIN1(0)	NU	NU

Table 18. Profile of Calibration Read Data Frames (Bank Mode Addressing)

FIELD NAME (BANK ADDRESS)	FIELD MODE ADDRESS	LENGTH	FRAME NO.	B7 (MSB)	B6	B5	B4	B3	B2	B1	B0 (LSB)
				DATA							
Sensor ID 0	00000	(43:0)	1	SENID(43)	SENID(42)	SENID(41)	SENID(40)	SENID(39)	SENID(38)	SENID(37)	SENID(36)
			2	SENID(35)	SENID(34)	SENID(33)	SENID(32)	SENID(31)	SENID(30)	SENID(29)	SENID(28)
			3	SENID(27)	SENID(26)	SENID(25)	SENID(24)	SENID(23)	SENID(22)	SENID(21)	SENID(20)
			4	SENID(19)	SENID(18)	SENID(17)	SENID(16)	SENID(15)	SENID(14)	SENID(13)	SENID(12)
			5	SENID(11)	SENID(10)	SENID(9)	SENID(8)	SENID(7)	SENID(6)	SENID(5)	SENID(4)
			6	SENID(3)	SENID(2)	SENID(1)	SENID(0)	NU	NU	NU	NU
Position ID (0)		(1:0)	7	PSNID(1)	PSNID(0)	NU	NU	NU	NU	NU	NU
OP threshold(1)	00001	(3:0)	1	TRHS(3)	TRHS(2)	TRHS(1)	TRHS(0)	NU	NU	NU	NU
OP timer(1)		(1:0)	2	TRDELAY(1)	TRDELAY(0)	NU	NU	NU	NU	NU	NU
OP gain(1)		(2:0)	3	TRHS GAIN(2)	TRHS GAIN(1)	TRHS GAIN(0)	NU	NU	NU	NU	NU
Baud rate(2)	00010	(3:0)	1	CONF BPS(3)	CONF BPS(2)	CONF BPS(1)	CONF BPS(0)	NU	NU	TRV OSC(10)	NU
Input coarse offset (3)	00011	(16:8)	1	TRV OSC(16)	TRV OSC(15)	TRV OSC(14)	TRV OSC(13)	TRV OSC(12)	TRV OSC(11)	NU	TRV OSC(9)
			2	TRV OSC(8)	NU	NU	NU	NU	NU	TRVOSF(1)	NU
Input fine offset(3)		(7:0)	3	TRVOSF(7)	TRVOSF(6)	TRVOSF(5)	TRVOSF(4)	TRVOSF(3)	TRVOSF(2)	TRTC VOS1(1)	TRVOSF(0)
Input offset first order temperature coefficient(3)		(6:0)	4	TRTC VOS1(6)	TRTC VOS1(5)	TRTC VOS1(4)	TRTC VOS1(3)	TRTC VOS1(2)	TRTC VOS1(1)	TRTC VOS2(0)	NU
Input offset second order temperature coefficient(3)		(6:0)	5	TRTC VOS2(6)	TRTC VOS2(5)	TRTC VOS2(4)	TRTC VOS2(3)	TRTC VOS2(2)	TRTC VOS2(1)	TRGAIN(2)	NU
Gain adjust(3)	00011	(8:0)	6	TRGAIN(8)	TRGAIN(7)	TRGAIN(6)	TRGAIN(5)	TRGAIN(4)	TRGAIN(3)	NU	TRGAIN(1)
			7	TRGAIN(0)	NU	NU	NU	NU	NU	NU	NU
Gain first order temperature coefficient(3)		(5:0)	8	TRTC GAIN1(5)	TRTC GAIN1(4)	TRTC GAIN1(3)	TRTC GAIN1(2)	TRTC GAIN1(1)	TRTC GAIN1(0)	TEMP0(5)	NU
Temperature sensor OUT 1 (4)	00100	(11:0)	1	TEMP0(11)	TEMP0(10)	TEMP0(9)	TEMP0(8)	TEMP0(7)	TEMP0(6)	NU	TEMP0(4)
			2	TEMP0(3)	TEMP0(2)	TEMP0(1)	TEMP0(0)	NU	NU	TEMP1(5)	NU
Temperature sensor OUT 2 (4)		(11:0)	3	TEMP1(11)	TEMP1(10)	TEMP1(9)	TEMP1(8)	TEMP1(7)	TEMP1(6)	NU	TEMP1(4)
			4	TEMP1(3)	TEMP1(2)	TEMP1(1)	TEMP1(0)	NU	NU	TEMP2(5)	NU
Temperature sensor OUT 3 (4)		(11:0)	5	TEMP2(11)	TEMP2(10)	TEMP2(9)	TEMP2(8)	TEMP2(7)	TEMP2(6)	NU	TEMP2(4)
			6	TEMP2(3)	TEMP2(2)	TEMP2(1)	TEMP2(0)	NU	NU	NU	NU

Table 18. Profile of Calibration Read Data Frames (Bank Mode Addressing) (continued)

FIELD NAME (BANK ADDRESS)	FIELD MODE ADDRESS	LENGTH	FRAME NO.	B7 (MSB)	B6	B5	B4	B3	B2	B1	B0 (LSB)
				DATA							
History of OP threshold (5)	00101	(3:0)	1	MTRHS(3)	MTRHS(2)	MTRHS(1)	MTRHS(0)	NU	NU		NU
History of OP timer (6)		(1:0)	2	MTR DELAY(1)	MTR DELAY(0)	NU	NU	NU	NU	NU	NU
History OP gain (6)		(2:0)	3	MTRHS GAIN(2)	MTRHS GAIN(1)	MTRHS GAIN(0)	NU	NU	NU	NU	NU
History of input offset(6)		(16:0)	4	MTR VOS(17)	MTR VOS(16)	MTR VOS(15)	MTR VOS(14)	MTR VOS(13)	MTR VOS(12)	MTR VOS(11)	MTR VOS(10)
			5	MTR VOS(9)	MTR VOS(8)	MTR VOS(7)	MTR VOS(6)	MTR VOS(5)	MTR VOS(4)	MTR VOS(3)	MTR VOS(2)
			6	MTR VOS(1)	MTR VOS(0)	NU	NU	NU	NU	NU	NU
History of Input offset first order temperature coefficient(6)		(6:0)	7	MTRTC VOS1(6)	MTRTC VOS1(5)	MTRTC VOS1(4)	MTRTC VOS1(3)	MTRTC VOS1(2)	MTRTC VOS1(1)	MTRTC VOS1(0)	NU
History of Input offset 2nd order temperature coefficient(6)		(6:0)	8	MTRTC VOS2(6)	MTRTC VOS2(5)	MTRTC VOS2(4)	MTRTC VOS2(3)	MTRTC VOS2(2)	MTRTC VOS2(1)	MTRTC VOS2(0)	NU
History of Gain adjust(6)		(8:0)	9	MTRGAIN(8)	MTRGAIN(7)	MTRGAIN(6)	MTRGAIN(5)	MTRGAIN(4)	MTRGAIN(3)	MTRGAIN(2)	MTRGAIN(1)
			10	MTRGAIN(0)	NU	NU	NU	NU	NU	NU	NU
History of Gain first order temperature coefficient(6)		(5:0)	11	MTRTC GAIN1(5)	MTRTC GAIN1(4)	MTRTC GAIN1(3)	MTRTC GAIN1(2)	MTRTC GAIN1(1)	MTRTC GAIN1(0)	NU	NU
DIAG/UART		(7:0)	1	Reserved	DG1	ECRC	PROG_OK	EIVCM	EFRAME	EOVER	EPAR
		(7:0)	2	Reserved	Reserved	Reserved	Reserved	Fastdis	Stbit	EO	Pdis

Table 19. DIAG/UART Register (Bank Address = 8)

ITEM	DESCRIPTION
DG1	Over pressure flag
ECRC	CRC error
PROG_OK	PROGV pin monitor
EIVCM	SIP and SIN pin common mode voltage error
EFRAME	Framing error
EOVER	Over run error
EPAR	Parity error
Pdis	Parity disable
EO	Parity even or odd
Stbit	Stop bit setting
Fastdis	Test mode baud rate disable
Reserved	Reserved

Calibration Mode – Mode Select

Mode Select Command Frames

7	6	5	4	3	2	1	0
PSNID(1)	PSNID(0)	WORDID	MODETYPE		DISPSN	Reserved	
PSNID(1)	PSNID(0)	WORDID	NU	NU	ACSUNT	ACTMODE	WE

First Frame

PSNID[1:0]	Bits 7-6	Position ID of device on UART bus. Each device process information for one sensor. Four sensors can be sensed on the UART bus. Position settings are defined in the EEPROM map. 00 Position 0 01 Position 1 10 Position 2 11 Position 3
WORDID	Bit 5	Frame ID of byte. 1 indicates frame 1 of 2.
MODETYPE	Bits 4-3	Select mode type within calibration mode 00 Data request 01 Calibration write 10 Calibration read 11 Mode select
DISPSN	Bit 2	Disable or enable position ID matching 0 Decode command only if position IDs match 1 Indicates global command. All devices decode command frame.
Reserved	Bits 1-0	Must be set to 0.

Second Frame

PSNID[1:0]	Bits 7-6	Position ID of device on UART bus. Each device process information for one sensor. Four sensors can be sensed on the UART bus. Position settings are defined in the EEPROM map. 00 Position 0 01 Position 1 10 Position 2 11 Position 3
WORDID	Bit 5	Frame ID of byte. 0 indicates frame 2 of 2.
NU	Bits 4-3	Not use. Set to 0.
ACSUNT	Bit 0	Sets device to field addressing mode or bank addressing mode. Can be accessed only in calibration mode. 0 Bank addressing mode 1 Field addressing mode
ACTMODE	Bit 1	Sets device to sensor or calibration mode after current command is completed. 0 Sensor mode 1 Calibration mode
WE	Bit 0	Disable/enable write to EEPROM (see EEPROM Write for details) 0 EEPROM write disabled (default) 1 EEPROM write enabled

Figure 13. Mode Select Command Frames

Mode Select Data Frames

	7	6	5	4	3	2	1	0
	NU	NU	NU	NU	NU	ACSUNT	ACTMODE	WE
NU	Bits 7-3	Not use. Set to 0.						
ACSUNT	Bit 0	Reports field addressing mode or bank addressing mode						
		0	Bank addressing mode					
		1	Field addressing mode					
ACTMODE	Bit 1	Reports sensor or calibration mode						
		0	Sensor mode					
		1	Calibration mode					
WE	Bit 0	Reports status of disable/enable write to EEPROM (see EEPROM Write for details)						
		0	EEPROM write disabled (default)					
		1	EEPROM write enabled					

Figure 14. Mode Select Data Frames
Table 20. Profile of Mode Select Data Frames (Field and Bank Mode Addressing)

FIELD NAME (BANK ADDRESS)	FIELD MODE ADDRESS	LENGTH	FRAME NO.	B7 (MSB)	B6	B5	B4	B3	B2	B1	B0 (LSB)
				DATA							
Mode registers read	-	-	1	NU	NU	NU	NU	NU	ACSUNT	ACTMODE	WE

Device Configuration and Thresholds

The following tables show the actual data settings needed in the specific control bits for setting the baud rates and threshold levels for the TPIC83000. These settings can only be implemented in Calibration mode.

Table 21. Baud Rate Settings

BAUD RATE	DATA	TYPICAL VALUE	COMMUNICATION CLOCK
CONF BPS(3:0)	0000	500 bps	2.458 MHz / 307 = 8.0 kHz
	0001	750 bps	2.458 MHz / 205 = 12.0 kHz
	0010	1000 bps	2.458 MHz / 154 = 16.0 kHz
	0011	1250 bps	2.458 MHz / 123 = 20.0 kHz
	0100	1500 bps	2.458 MHz / 102 = 24.0 kHz
	0101	1750 bps	2.458 MHz / 88 = 27.9 kHz
	0110	2000 bps	2.458 MHz / 77 = 31.9 kHz
	0111	2250 bps	2.458 MHz / 68 = 36.1 kHz
	1000	2500 bps	2.458 MHz / 61 = 40.0 kHz
	1001	2750 bps	2.458 MHz / 56 = 43.9 kHz
	1010	3000 bps	2.458 MHz / 51 = 48.2 kHz
	1011	3250 bps	2.458 MHz / 47 = 52.3 kHz
	1100	4800 bps	2.458 MHz / 32 = 76.8 kHz
	1101	9600 bps	2.458 MHz / 16 = 153.6 kHz
	1110	19.2 kbps	2.458 MHz / 8 = 307.3 kHz
	1111	38.4 kbps	2.458 MHz / 4 = 614.5 kHz

Table 22. Over-Pressure Gain Settings via TRHSGAIN Control Bits

OVER-PRESSURE GAIN	DATA	MIN VALUE	TYPICAL VALUE	MAX VALUE
TRHSGAIN(2:0)	0000		2.2	
	0001		2.4	
	0010		2.6	
	0011		2.8	
	0100		3	
	0101		3.2	
	0110		3.4	
	0111		3.6	

Table 23. Over-Pressure Thresholds at Over-Pressure Gain = 2.2

OVER-PRESSURE THRESHOLD	DATA	MIN VALUE	TYPICAL VALUE	MAX VALUE
TRHS(3:0)	0000	-20%	9.41 mV	20%
TRHSGAIN = 0 Error due to coarse offset value should be taken into account. Input referred.	0001	-20%	10.59 mV	20%
	0010	-20%	11.77 mV	20%
	0011	-20%	12.93 mV	20%
	0100	-20%	14.11 mV	20%
	0101	-20%	15.29 mV	20%
	0110	-20%	16.47 mV	20%
	0111	-20%	17.64 mV	20%
	1000	-10%	18.82 mV	10%
	1001	-10%	20.00 mV	10%
	1010	-10%	21.17 mV	10%
	1011	-10%	22.34 mV	10%
	1100	-10%	23.52 mV	10%
	1101	-10%	24.70 mV	10%
	1110	-10%	25.88 mV	10%
	1111	-10%	27.06 mV	10%

Table 24. Over-Pressure Thresholds at Over-Pressure Gain = 2.4

OVER-PRESSURE THRESHOLD	DATA	MIN VALUE	TYPICAL VALUE	MAX VALUE
TRHS(3:0)	0000	-20%	8.92 mV	20%
TRHSGAIN = 1 Error due to coarse offset value should be taken into account. Input referred.	0001	-20%	10.03 mV	20%
	0010	-20%	11.15 mV	20%
	0011	-20%	12.25 mV	20%
	0100	-20%	13.37 mV	20%
	0101	-20%	14.48 mV	20%
	0110	-20%	15.60 mV	20%
	0111	-20%	16.72 mV	20%
	1000	-10%	17.83 mV	10%
	1001	-10%	18.95 mV	10%
	1010	-10%	20.05 mV	10%
	1011	-10%	21.17 mV	10%
	1100	-10%	22.28 mV	10%
	1101	-10%	23.40 mV	10%
	1110	-10%	24.52 mV	10%
	1111	-10%	25.63 mV	10%

Table 25. Over-Pressure Thresholds at Over-Pressure Gain = 2.6

OVER-PRESSURE THRESHOLD	DATA	MIN VALUE	TYPICAL VALUE	MAX VALUE
TRHS(3:0)	0000	-20%	8.42 mV	20%
TRHSGAIN = 2 Error due to coarse offset value should be taken into account. Input referred.	0001	-20%	9.47 mV	20%
	0010	-20%	10.53 mV	20%
	0011	-20%	11.57 mV	20%
	0100	-20%	12.63 mV	20%
	0101	-20%	13.67 mV	20%
	0110	-20%	14.73 mV	20%
	0111	-20%	15.78 mV	20%
	1000	-10%	16.84 mV	10%
	1001	-10%	17.89 mV	10%
	1010	-10%	18.94 mV	10%
	1011	-10%	19.99 mV	10%
	1100	-10%	21.04 mV	10%
	1101	-10%	22.10 mV	10%
	1110	-10%	23.15 mV	10%
	1111	-10%	24.21 mV	10%

Table 26. Over-Pressure Thresholds at Over-Pressure Gain = 2.8

OVER-PRESSURE THRESHOLD	DATA	MIN VALUE	TYPICAL VALUE	MAX VALUE
TRHS(3:0)	0000	-20%	7.93 mV	20%
TRHSGAIN = 3 Error due to coarse offset value should be taken into account. Input referred.	0001	-20%	8.92 mV	20%
	0010	-20%	9.91 mV	20%
	0011	-20%	10.89 mV	20%
	0100	-20%	11.88 mV	20%
	0101	-20%	12.87 mV	20%
	0110	-20%	13.87 mV	20%
	0111	-20%	14.86 mV	20%
	1000	-10%	15.85 mV	10%
	1001	-10%	16.84 mV	10%
	1010	-10%	17.82 mV	10%
	1011	-10%	18.82 mV	10%
	1100	-10%	19.81 mV	10%
	1101	-10%	20.80 mV	10%
	1110	-10%	21.79 mV	10%
	1111	-10%	22.78 mV	10%

Table 27. Over-Pressure Thresholds at Over-Pressure Gain = 3.0

OVER-PRESSURE THRESHOLD	DATA	MIN VALUE	TYPICAL VALUE	MAX VALUE
TRHS(3:0)	0000	-20%	7.43 mV	20%
TRHSGAIN = 4 Error due to coarse offset value should be taken into account. Input referred.	0001	-20%	8.36 mV	20%
	0010	-20%	9.29 mV	20%
	0011	-20%	10.21 mV	20%
	0100	-20%	11.14 mV	20%
	0101	-20%	12.07 mV	20%
	0110	-20%	13.00 mV	20%
	0111	-20%	13.93 mV	20%
	1000	-10%	14.86 mV	10%
	1001	-10%	15.79 mV	10%
	1010	-10%	16.71 mV	10%
	1011	-10%	17.64 mV	10%
	1100	-10%	18.57 mV	10%
	1101	-10%	19.50 mV	10%
	1110	-10%	20.43 mV	10%
	1111	-10%	21.36 mV	10%

Table 28. Over-Pressure Thresholds at Over-Pressure Gain = 3.2

OVER-PRESSURE THRESHOLD	DATA	MIN VALUE	TYPICAL VALUE	MAX VALUE
TRHS(3:0)	0000	-20%	6.93 mV	20%
TRHSGAIN = 5 Error due to coarse offset value should be taken into account. Input referred.	0001	-20%	7.80 mV	20%
	0010	-20%	8.67 mV	20%
	0011	-20%	9.53 mV	20%
	0100	-20%	10.40 mV	20%
	0101	-20%	11.27 mV	20%
	0110	-20%	12.13 mV	20%
	0111	-20%	13.00 mV	20%
	1000	-10%	13.87 mV	10%
	1001	-10%	14.73 mV	10%
	1010	-10%	15.59 mV	10%
	1011	-10%	16.46 mV	10%
	1100	-10%	17.33 mV	10%
	1101	-10%	18.2 mV	10%
	1110	-10%	19.07 mV	10%
	1111	-10%	19.94 mV	10%

Table 29. Over-Pressure Thresholds at Over-Pressure Gain = 3.4

OVER-PRESSURE THRESHOLD	DATA	MIN VALUE	TYPICAL VALUE	MAX VALUE
TRHS(3:0)	0000	-20%	6.44 mV	20%
TRHSGAIN = 6 Error due to coarse offset value should be taken into account. Input referred.	0001	-20%	7.25 mV	20%
	0010	-20%	8.05 mV	20%
	0011	-20%	8.84 mV	20%
	0100	-20%	9.65 mV	20%
	0101	-20%	10.46 mV	20%
	0110	-20%	11.27 mV	20%
	0111	-20%	12.07 mV	20%
	1000	-10%	12.87 mV	10%
	1001	-10%	13.69 mV	10%
	1010	-10%	14.48 mV	10%
	1011	-10%	15.29 mV	10%
	1100	-10%	16.09 mV	10%
	1101	-10%	16.90 mV	10%
	1110	-10%	17.71 mV	10%
	1111	-10%	18.51 mV	10%

Table 30. Over-Pressure Thresholds at Over-Pressure Gain = 3.6

OVER-PRESSURE THRESHOLD	DATA	MIN VALUE	TYPICAL VALUE	MAX VALUE
TRHS(3:0)	0000	-20%	5.94 mV	20%
TRHSGAIN = 7 Error due to coarse offset value should be taken into account. Input referred.	0001	-20%	6.69 mV	20%
	0010	-20%	7.43 mV	20%
	0011	-20%	8.17 mV	20%
	0100	-20%	8.91 mV	20%
	0101	-20%	9.66 mV	20%
	0110	-20%	10.4 mV	20%
	0111	-20%	11.14 mV	20%
	1000	-10%	11.89 mV	10%
	1001	-10%	12.63 mV	10%
	1010	-10%	13.37 mV	10%
	1011	-10%	14.11 mV	10%
	1100	-10%	14.85 mV	10%
	1101	-10%	15.60 mV	10%
	1110	-10%	16.34 mV	10%
	1111	-10%	17.08 mV	10%

Table 31. Over-Pressure Timer Configuration via TRDELAY Control Bits

OVER-PRESSURE TIMER	DATA	MIN VALUE	TYPICAL VALUE	MAX VALUE
TRDELAY(1:0)	00	$(2/2.458 \text{ MHz}) \times 1000 \times 0.9$	$(2/2.458 \text{ MHz}) \times 1000 \text{ s}$	$(2/2.458 \text{ MHz}) \times 1000 \times 1.1$
	01	$(2/2.458 \text{ MHz}) \times 2000 \times 0.9$	$(2/2.458 \text{ MHz}) \times 2000 \text{ s}$	$(2/2.458 \text{ MHz}) \times 2000 \times 1.1$
	10	$(2/2.458 \text{ MHz}) \times 3000 \times 0.9$	$(2/2.458 \text{ MHz}) \times 3000 \text{ s}$	$(2/2.458 \text{ MHz}) \times 3000 \times 1.1$
	11	$(2/2.458 \text{ MHz}) \times 4000 \times 0.9$	$(2/2.458 \text{ MHz}) \times 4000 \text{ s}$	$(2/2.458 \text{ MHz}) \times 4000 \times 1.1$

Table 32. Default Settings for Temperature Sensor (Data 2) With Respect to Over-Pressure Comparator Timer and Gain Adjust

	TEST CONDITIONS	
OP-1		TEMP1[5:0]
12.483 mV ≤ VPHS ≤ 12.57 mV	TRHS = 8, TRHSGAIN = 5	10
12.57 mV < VPHS ≤ 13.44 mV	TRHS = 8, TRHSGAIN = 5	9
13.44 mV < VPHS ≤ 14.30 mV	TRHS = 8, TRHSGAIN = 5	8
14.30 mV < VPHS ≤ 15.257 mV	TRHS = 8, TRHSGAIN = 5	7
OP-2		TEMP1[9:6]
16.38 mV < VPHS ≤ 16.895 mV	TRHS = 13, TRHSGAIN = 5	15
16.895 mV < VPHS ≤ 17.765 mV	TRHS = 13, TRHSGAIN = 5	14
17.765 mV < VPHS ≤ 18.635 mV	TRHS = 13, TRHSGAIN = 5	13
18.635 mV < VPHS ≤ 19.505 mV	TRHS = 13, TRHSGAIN = 5	12
19.505 mV < VPHS ≤ 20.020 mV	TRHS = 13, TRHSGAIN = 5	11

ABSOLUTE MAXIMUM RATINGS⁽¹⁾

over operating free-air temperature range (unless otherwise noted)

		VALUE	UNIT
V _{cc} /V _{dd}	Regulated input ^{(2) (3)}	-0.3 to 7	V
DO	Output ^{(2) (4)}	-0.3 to 7	V
DI	Input ^{(2) (4)}	-0.3 to 7	V
SIN/SIP	Input voltage ^{(2) (3)}	-0.3 to V _{cc} + 0.3	V
P _D	Continuous power dissipation	71	mW
θ _{JA}	Thermal impedance, junction to ambient	100	°C/W
ESD1 ⁽⁵⁾	Electrostatic discharge ⁽⁶⁾	±2	kV
ESD2 ⁽⁷⁾	Electrostatic discharge on all terminals	-200 (Minimum)	V
		200 (Maximum)	V
T _{OP}	Operating ambient temperature range	-40 to 85	°C
T _S	Storage temperature range	-40 to 125	°C
T _J	Maximum junction temperature	150	°C

- (1) Stresses beyond those listed under *absolute maximum ratings* may cause permanent damage to the device. These are stress ratings only, and functional operation of the device at these or any other conditions beyond those indicated under *recommended operating conditions* is not implied. Exposure to absolute-maximum-rated conditions for extended periods may affect device reliability.
- (2) All voltage values are with respect to GND.
- (3) Absolute negative voltage on these pins not to go below -0.5 V. This is to prevent the ESD diode from forward-biasing during normal operation.
- (4) Absolute negative voltage on these pins not to go below -1.0 V. This is to prevent the ESD diode from forward-biasing during normal operation.
- (5) ESD1: DO pin with 220 Ω and 1 nF (cannot be disruptive or destructive)
- (6) The human body model is a 100 pF capacitor discharged through a 1.5-kΩ resistor into each pin
- (7) ESD2: On all other terminals 0 Ω with 200 pF

RECOMMENDED OPERATING CONDITIONS

		MIN	NOM	MAX	UNIT
V _{dd} , V _{cc} , V _{ccA}	Regulated input	4.5	5	5.25	V
DO	Output	0		V _{dd}	V
DI	Input	0		V _{dd}	V
SIN, SIP	Amplifier input voltage	V _{cc} /2 - 0.2		V _{cc} /2 + 0.2	V
C _{ProgV}	Programming voltage capacitor for charge pump	500		1500	pF
R _{refl}	Current reference setting		10		kΩ
Q _{Vcc}	Low ESR capacitance on V _{cc} line	1			μF
T _A	Operating ambient temperature	-40		85	°C

ELECTRICAL CHARACTERISTICS – POWER SUPPLY

Vdd = Vcc = VccA = 5 V +5%/–10%, TA = –40°C to 85°C (unless otherwise noted)

PARAMETER		TEST CONDITIONS	MIN	TYP	MAX	UNIT
Power Supply						
Vcc Vdd VccA	Power supply voltage		4.5	5.0	5.25	V
IVcc IVdd IVccA	Total current consumption of all three supplies	Vcc = 5 V, TA = 25°C		10		mA
		All specified operating conditions			13	mA
		Vcc = 5 V, TA = 25°C, EEPROM programming mode			13.5	mA
Power-On Reset						
UVcc ^{(1) (2)}	Vcc undervoltage detection threshold	DO = 0	3.5	3.7	3.8	V
HVcc	Vcc undervoltage detection hysteresis	Vcc = Vdd = VccA		0.2		V
TPOR ^{(1) (2)}		See Figure 15	9.54	10.6	11.66	ms

- (1) 1.3-ms timer between PUC (power up clear, Vcc = 2.5 V) to UVcc
- (2) PUC clears digital logic core. UVcc holds DO to low state. After UVCC condition cleared, DO is low for TPOR.

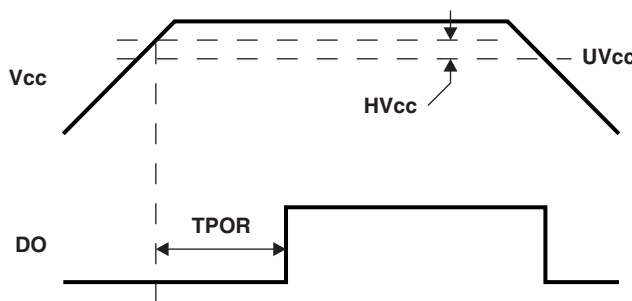

Figure 15. Power-On Reset Voltage and Timing Thresholds

ELECTRICAL CHARACTERISTICS – INPUT AMPLIFIER (SIP, SIN)

Vdd = Vcc = VccA = 5 V +5%/–10%, TA = –40°C to 85°C (unless otherwise noted)

PARAMETER		TEST CONDITIONS	MIN	TYP	MAX	UNIT
VICOM	Input common mode range SIP and SIN	$\Delta DO/\Delta V_{cm}$ (10-bit scale) <1-bit error at output	Vcc/2 –0.2		Vcc/2 +0.2	V
VIDF ⁽¹⁾	Input differential voltage between SIP and SIN	Coarse offset range	–120		120	mV
VOS	Input offset voltage	Vcc = 5 V, VSIP = VSIN = 2.5 V	–20		20	μ V
ISI	Input offset current	Rin = 500 k, VSIP = VSIN = Vcc/2	–0.2		0.2	μ A
IS	Input sink current	SIP = SIN = Vcc/2	0.5	1	2.5	μ A
CSI	Amplifier input load capacitance	SIP to Gnd SIN to Gnd SIP to SIN			0.1	μ F

- (1) This is typical coarse offset range correction range. Refer to the coarse offset DAC section for accuracy information.

ELECTRICAL CHARACTERISTICS – CALIBRATION AND FAULT DETECTION

V_{dd} = V_{cc} = V_{ccA} = 5 V +5%/–10%, T_A = –40°C to 85°C (unless otherwise noted)

PARAMETER		TEST CONDITIONS	MIN	TYP	MAX	UNIT
Calibration						
V _{os}	Input offset trim range		–120		120	mV
	Input offset trimming step			8		μV
	Input offset trimming resolution			17		bits
	VOSC (coarse)	V _{in} = 0, Gain = Nom	–132		132	mV
	VOSF (fine)	V _{in} = 0, Gain = Nom		328		bits
TCV _{os1}	Input offset TC1 trim range +	VO(TCV _{os1} = 63 or –64) –VO(TCV _{os1} = 0)	48	72	96	LSB
	Input offset TC1 trim range –		–99	–74	–48	LSB
	Input offset TC1 trim step	V _{in} = 0, GAIN = Mid, T _A = 85°C,		1.14		LSB/ Code
	Input offset TC1 trimming resolution			7		bits
TCV _{os2}	Input offset TC2 trim range +	VO(TCV _{os2} = 63 or –64) –VO(TCV _{os2} = 0)	12	24	35	LSB
	Input offset TC2 trim range –		–35	–24	–12	LSB
	Input offset TC2 trim step	V _{in} = 0, GAIN = Mid, T _A = 85°C		0.38		LSB/ Code
	Input offset TC2 trimming resolution			7		bits
Gain	Programmable gain range	With respect to Analog Gain	75		125	%
	Gain programming step	V _{in} = SIP – SIN			0.1	%
	Gain programming resolution			9		bits
TCG _{ain1}	Gain TC1 trimming range	VO(TCG _{ain1} = 1) – VO(TCG _{ain1} = 0)	–44	–35	–20	LSB
	Gain TC1 trimming step			0.55		LSB/ Code
	Gain TC1 number of bits	V _{in} = 1.1/ 300 V, GAIN = Mid, T _A = 85°C		6		bits
Fault Detection						
VIOVL	Input under levels	SIP and SIN	0.1 V _{cc}		0.3 V _{cc}	V
VIOVH	Input over levels	SIP and SIN	0.7 V _{cc}		0.9 V _{cc}	V
TIOV	Input fault deglitch timer	SIP and SIN	4.5	5	5.5	ms
VIHS	Typical excess pressure detection programmable range	SIP and SIN TRHSGAIN = 5 TRHS = 0 to 15	–19.94		–6.93	mV
VPHS	Typical programmable step accuracy	SIP and SIN	–1.1		1.1	mV
VRHS	Typical programmable step	SIP and SIN TRHSGAIN = 5		0.87		mV
TIOW	Deglitch timer programmable range	TRDELAY = 3		(2/ 2.458 MHz) × 4000		s
TIOWE	Over-pressure deglitch time error	SIP and SIN	–10	0	10	%
TSF	Supply glitch time	V _{cc} < 2.5 V		320		ns

ELECTRICAL CHARACTERISTICS – EEPROM

V_{dd} = V_{cc} = V_{ccA} = 5 V +5%/–10%, T_A = –40°C to 85°C (unless otherwise noted)

PARAMETER		TEST CONDITIONS	MIN	TYP	MAX	UNIT
Write cycle		DIO and PROG V			25	times
Write time	EEPROM write time	DIO and PROG V	20		120	ms
	T _{prog_ok} + system response time	T _{prog_ok} + system response time				
PROG_OK timer	T _{prog_ok}	PROG V > V _{PROG}	13.5	15	16.5	ms
Programming voltage	V _{PROG}	PROG V	12.5		18	V
Write T _A			–40		85	°C

ELECTRICAL CHARACTERISTICS – AFE

V_{dd} = V_{cc} = V_{ccA} = 5 V +5%/–10%, T_A = –40°C to 85°C (unless otherwise noted)

PARAMETER		TEST CONDITIONS	MIN	TYP	MAX	UNIT
A _v	Analog front end gain	At TST1 and TST0, V _{in} = ±3 mV, T _A = 25°C	285	300	321	V/V
ASIG	Signal path absolute error	V _{in} = ±3 mV	–16		16	LSB
RE4085	Ratiometric error at –40°C and 85°C	DIO Pin, V _{cc} = 4.92±50 mV, Gain = Max	–13		13	LSB
TCVO1	Output temperature drift	Input = GND, Temp = –40°C to 25°C, the offset TCs are set to the middle, Gain = Max	–15		15	LSB
TCVO2	Output temperature drift	Input = GND, Temp = 25°C to 85°C, the offset TCs are set to the middle, Gain = Max	–10		10	LSB
TCAG	Analog front end gain temperature drift	At TST1 and TST0, V _{in} = ±3 mV	–0.5	0	0.5	%
TCVIONL	Output drift, second order	TCVO1 – TCVO2	–20	0	20	LSB
GAINNL	Gain non linearity	At TST1/ TST0, V _{in} = –3 mV, 1 mV	–20	0	20	mV

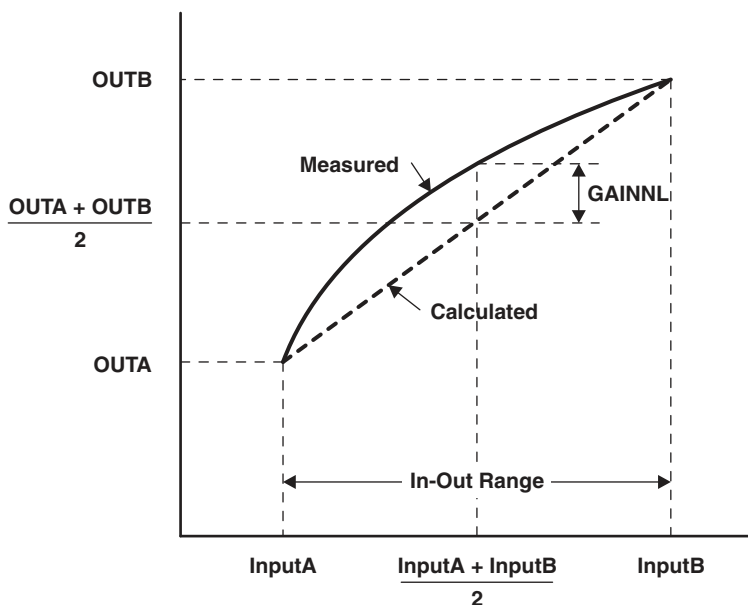

Figure 16. Analog Front-End Gain Non-Linearity (Measured vs Calculated)

ELECTRICAL CHARACTERISTICS – Data Input-Output (DI/DO)

V_{dd} = V_{cc} = V_{ccA} = 5 V +5%/–10%, T_A = –40°C to 85°C (unless otherwise noted)

PARAMETER		TEST CONDITIONS	MIN	TYP	MAX	UNIT
Data Input-Output (DI/DO)						
LD	Data length	Word length		10		Bits
VDOL	Output low level	I _{sink} = 5 mA			0.1 V _{cc}	V
VDOH	Output high level	External pullup	0.9 V _{cc}			V
CDIO	Capacitive load	No Oscillation	1000			pF
Isink2	Output sink current	Rx mode, High impedance (Z state)	0		1	μA
DOH	Output high clamp			1023		
DOL	Output low clamp			0		
DOER	Accuracy	Include life-time drift	-1		1	%FS
VDIL	Input low level				0.3 V _{cc}	V
VDIH	Input high level		0.7 V _{cc}			V
RDI1	Input resistance	Pullup / DI = 2.5 V / 0 V	30	50	70	kΩ
ID1	Input leakage	DI = V _{cc}			1	μA
TRFDO1 ⁽¹⁾	DO rise / fall time for 500 to 2250 baud rate	f _{osc} = 2.458 MHz, C = 1 nF, CONFBPS < 8			4.7	μs
TRFDO2 ⁽¹⁾	DO rise / fall time for 2500 to 38.4k baud rate	f _{osc} = 2.458 MHz, C = 1 nF, CONFBPS > 7			1	μs
Data Input-Output Tx, Rx requirements						
f _{osc}	Internal clock frequency	T _A = -40, 85°C, REFI = 10 kΩ	2.25	2.4575	2.65	MHz
f _{comclk}	Internal communication clock frequency	f _{osc} = 2.458 MHz, At TST1 in test mode		BR ⁽²⁾ × 16		Hz
t _{strto}	Start bit output time	f _{osc} = 2.458 MHz		1/ baud rate		ms
t _{strt1}	Start bit decision time	f _{osc} = 2.458 MHz		8 / (BR ⁽²⁾ × 16) 16 / (BR ⁽²⁾ × 16)		ms
t _{stpo}	Stop bit	f _{osc} = 2.458 MHz		1/ BR ⁽²⁾		ms
t _{stpi}	Stop bit decision time	f _{osc} = 2.458 MHz		8 / (BR ⁽²⁾ × 16) 16 / (BR ⁽²⁾ × 16)		ms
t _{rtx}	RX-TX interval	f _{osc} = 2.458 MHz	1	1.5 2		bit
t _{tx}	TX-TX interval	f _{osc} = 2.458 MHz	1.5	2 2.5		bit

- (1) External R and C need to be chosen so that total communication speed error is less than (4.5% - system error).
- (2) BR = baud rate

ELECTRICAL CHARACTERISTICS – REFI

V_{dd} = V_{cc} = V_{ccA} = 5 V +5%/–10%, T_A = –40°C to 85°C (unless otherwise noted)

PARAMETER		TEST CONDITIONS	MIN	TYP	MAX	UNIT
V _{REFI}	Voltage across REFI pin	R = 10 kΩ	1.425	1.5	1.575	V
I _{REFI}	Current out of REFI pin	R = 10 kΩ	142.5	150	157.5	μA
C _{REFI}	Maximum capacitance				20	pF

APPLICATION INFORMATION

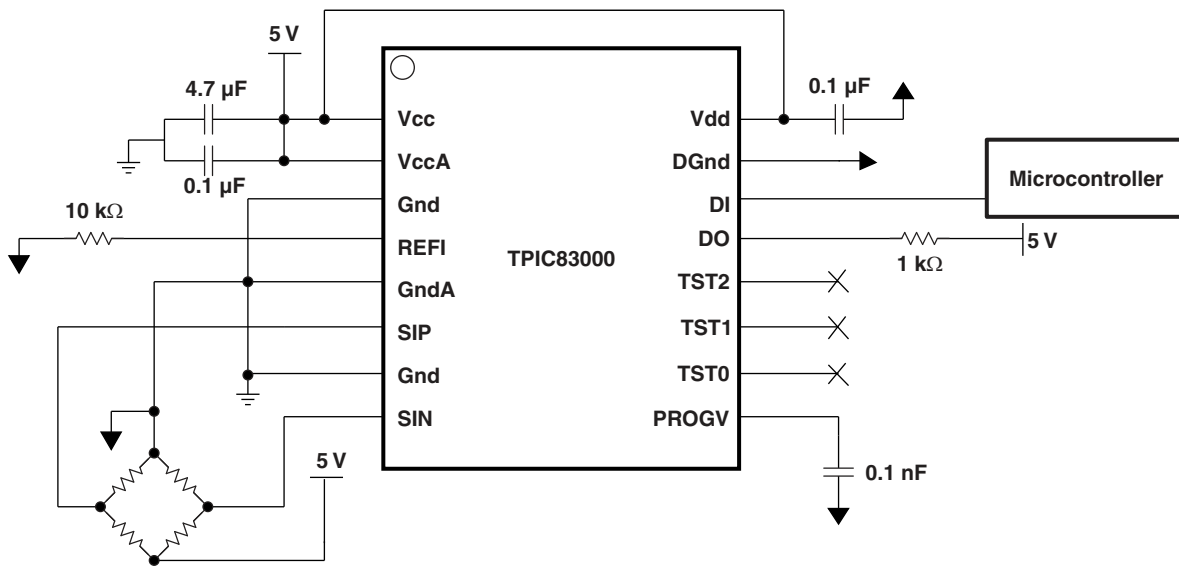

Figure 17. General Application Circuit

PACKAGING INFORMATION

Orderable Device	Status (1)	Package Type	Package Drawing	Pins	Package Qty	Eco Plan (2)	Lead/Ball Finish (6)	MSL Peak Temp (3)	Op Temp (°C)	Device Marking (4/5)	Samples
TPIC83000IPWRQ1	LIFEBUY	TSSOP	PW	16		Green (RoHS & no Sb/Br)	CU NIPDAU	Level-1-260C-UNLIM		TPIC83000I	

(1) The marketing status values are defined as follows:

ACTIVE: Product device recommended for new designs.

LIFEBUY: TI has announced that the device will be discontinued, and a lifetime-buy period is in effect.

NRND: Not recommended for new designs. Device is in production to support existing customers, but TI does not recommend using this part in a new design.

PREVIEW: Device has been announced but is not in production. Samples may or may not be available.

OBSELETE: TI has discontinued the production of the device.

(2) **RoHS:** TI defines "RoHS" to mean semiconductor products that are compliant with the current EU RoHS requirements for all 10 RoHS substances, including the requirement that RoHS substance do not exceed 0.1% by weight in homogeneous materials. Where designed to be soldered at high temperatures, "RoHS" products are suitable for use in specified lead-free processes. TI may reference these types of products as "Pb-Free".

RoHS Exempt: TI defines "RoHS Exempt" to mean products that contain lead but are compliant with EU RoHS pursuant to a specific EU RoHS exemption.

Green: TI defines "Green" to mean the content of Chlorine (Cl) and Bromine (Br) based flame retardants meet JS709B low halogen requirements of <=1000ppm threshold. Antimony trioxide based flame retardants must also meet the <=1000ppm threshold requirement.

(3) MSL, Peak Temp. - The Moisture Sensitivity Level rating according to the JEDEC industry standard classifications, and peak solder temperature.

(4) There may be additional marking, which relates to the logo, the lot trace code information, or the environmental category on the device.

(5) Multiple Device Markings will be inside parentheses. Only one Device Marking contained in parentheses and separated by a "~" will appear on a device. If a line is indented then it is a continuation of the previous line and the two combined represent the entire Device Marking for that device.

(6) Lead/Ball Finish - Orderable Devices may have multiple material finish options. Finish options are separated by a vertical ruled line. Lead/Ball Finish values may wrap to two lines if the finish value exceeds the maximum column width.

Important Information and Disclaimer:The information provided on this page represents TI's knowledge and belief as of the date that it is provided. TI bases its knowledge and belief on information provided by third parties, and makes no representation or warranty as to the accuracy of such information. Efforts are underway to better integrate information from third parties. TI has taken and continues to take reasonable steps to provide representative and accurate information but may not have conducted destructive testing or chemical analysis on incoming materials and chemicals. TI and TI suppliers consider certain information to be proprietary, and thus CAS numbers and other limited information may not be available for release.

In no event shall TI's liability arising out of such information exceed the total purchase price of the TI part(s) at issue in this document sold by TI to Customer on an annual basis.

TAPE AND REEL INFORMATION



QUADRANT ASSIGNMENTS FOR PIN 1 ORIENTATION IN TAPE



*All dimensions are nominal

Device	Package Type	Package Drawing	Pins	SPQ	Reel Diameter (mm)	Reel Width W1 (mm)	A0 (mm)	B0 (mm)	K0 (mm)	P1 (mm)	W (mm)	Pin1 Quadrant
TPIC83000IPWRQ1	TSSOP	PW	16	2000	330.0	12.4	6.9	5.6	1.6	8.0	12.0	Q1

TAPE AND REEL BOX DIMENSIONS



*All dimensions are nominal

Device	Package Type	Package Drawing	Pins	SPQ	Length (mm)	Width (mm)	Height (mm)
TPIC83000IPWRQ1	TSSOP	PW	16	2000	350.0	350.0	43.0

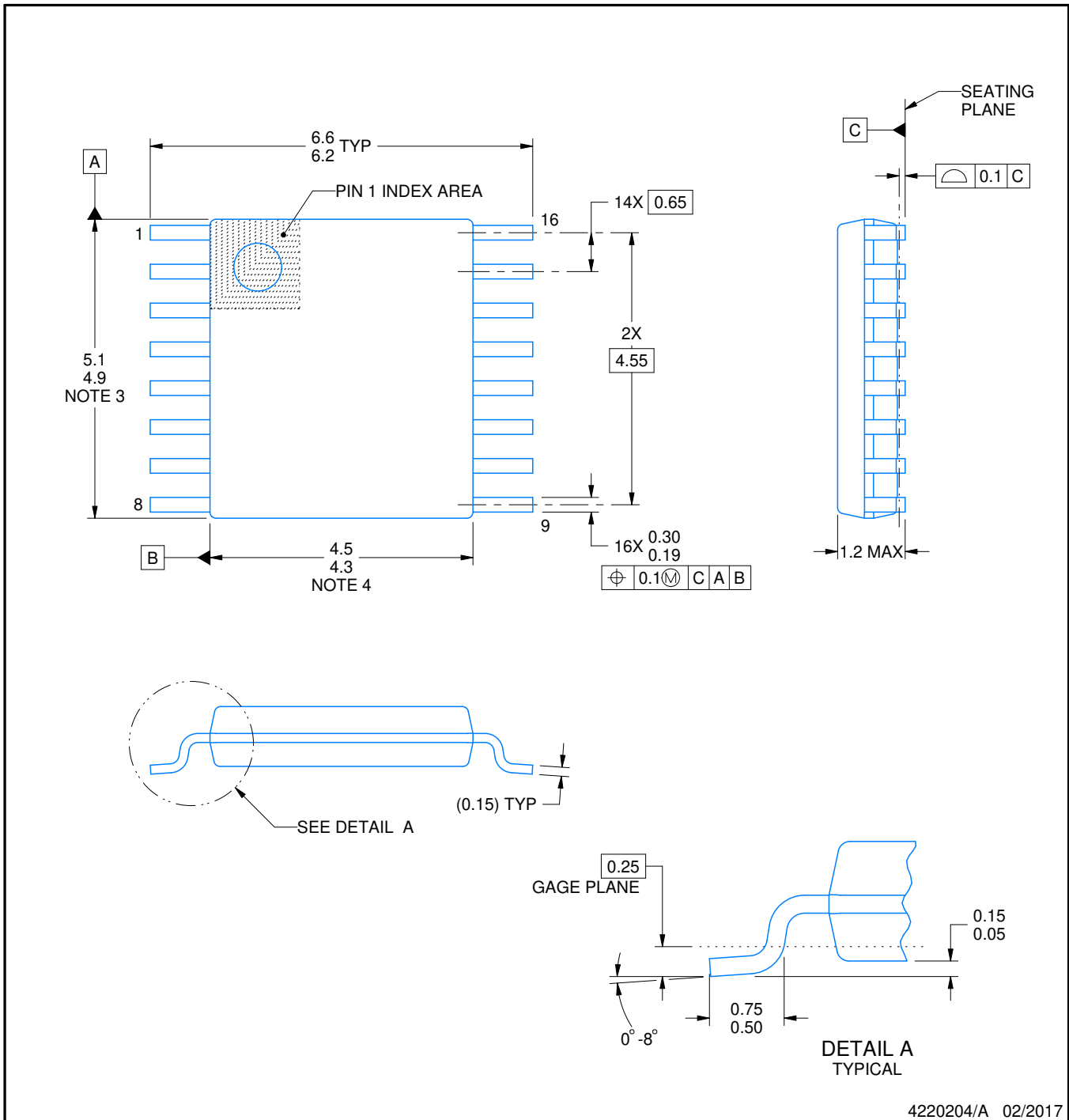

4220204/A 02/2017

NOTES:

1. All linear dimensions are in millimeters. Any dimensions in parenthesis are for reference only. Dimensioning and tolerancing per ASME Y14.5M.
2. This drawing is subject to change without notice.
3. This dimension does not include mold flash, protrusions, or gate burrs. Mold flash, protrusions, or gate burrs shall not exceed 0.15 mm per side.
4. This dimension does not include interlead flash. Interlead flash shall not exceed 0.25 mm per side.
5. Reference JEDEC registration MO-153.

EXAMPLE BOARD LAYOUT

PW0016A

TSSOP - 1.2 mm max height

SMALL OUTLINE PACKAGE



LAND PATTERN EXAMPLE
EXPOSED METAL SHOWN
SCALE: 10X



SOLDER MASK DETAILS

4220204/A 02/2017

NOTES: (continued)

- 6. Publication IPC-7351 may have alternate designs.
- 7. Solder mask tolerances between and around signal pads can vary based on board fabrication site.

EXAMPLE STENCIL DESIGN

PW0016A

TSSOP - 1.2 mm max height

SMALL OUTLINE PACKAGE



SOLDER PASTE EXAMPLE
BASED ON 0.125 mm THICK STENCIL
SCALE: 10X

4220204/A 02/2017

NOTES: (continued)

8. Laser cutting apertures with trapezoidal walls and rounded corners may offer better paste release. IPC-7525 may have alternate design recommendations.
9. Board assembly site may have different recommendations for stencil design.

IMPORTANT NOTICE AND DISCLAIMER

TI PROVIDES TECHNICAL AND RELIABILITY DATA (INCLUDING DATASHEETS), DESIGN RESOURCES (INCLUDING REFERENCE DESIGNS), APPLICATION OR OTHER DESIGN ADVICE, WEB TOOLS, SAFETY INFORMATION, AND OTHER RESOURCES "AS IS" AND WITH ALL FAULTS, AND DISCLAIMS ALL WARRANTIES, EXPRESS AND IMPLIED, INCLUDING WITHOUT LIMITATION ANY IMPLIED WARRANTIES OF MERCHANTABILITY, FITNESS FOR A PARTICULAR PURPOSE OR NON-INFRINGEMENT OF THIRD PARTY INTELLECTUAL PROPERTY RIGHTS.

These resources are intended for skilled developers designing with TI products. You are solely responsible for (1) selecting the appropriate TI products for your application, (2) designing, validating and testing your application, and (3) ensuring your application meets applicable standards, and any other safety, security, or other requirements. These resources are subject to change without notice. TI grants you permission to use these resources only for development of an application that uses the TI products described in the resource. Other reproduction and display of these resources is prohibited. No license is granted to any other TI intellectual property right or to any third party intellectual property right. TI disclaims responsibility for, and you will fully indemnify TI and its representatives against, any claims, damages, costs, losses, and liabilities arising out of your use of these resources.

TI's products are provided subject to TI's Terms of Sale (www.ti.com/legal/termsofsale.html) or other applicable terms available either on ti.com or provided in conjunction with such TI products. TI's provision of these resources does not expand or otherwise alter TI's applicable warranties or warranty disclaimers for TI products.

Mailing Address: Texas Instruments, Post Office Box 655303, Dallas, Texas 75265
Copyright © 2019, Texas Instruments Incorporated