

LOC		DIST		REVISIONS			
AD	00	P	LTH	DESCRIPTION	DATE	DWN	APVD
		A		RELEASED PER ECO-10-012478	24JUNE2010	DH	DY
		B1		REV PER ECO-20-004668	21APR2020	ML	SZ

- 1 MATERIAL
HOUSING: POLYESTER, COLOR, GRAY, UL 94V-0.
CONTACT: PHOSPHOR BRONZE, HIGH CURRENT COPPER ALLOY.
- 2 FINISH
IN ACCORDANCE WITH PRODUCT SPECIFICATION 108-1651,
GOLD PLATING OR EQUIVALENT PLATING ON PRODUCT CONTACT MATING AREA,
AND MATTE TIN PLATING ON COMPLIANT PIN AREA, ALL OVER MATTE NICKEL
UNDERPLATED. DETAIL PLEASE REFER TO PRODUCT SPECIFICATION 108-1651.
- 3 TOLERANCE TO BE ± 0.25 BEFORE CONNECTOR IS APPLIED TO PC BOARD.
- 4 REFERENCE APPLICATION SPEC 114-1103 FOR
RECOMMENDED PLATED THRU HOLE DIAMETER AND
PLATING THICKNESS.
5. CURRENT RATING 16A/CONTACT PER PRODUCT SPEC 108-1651.

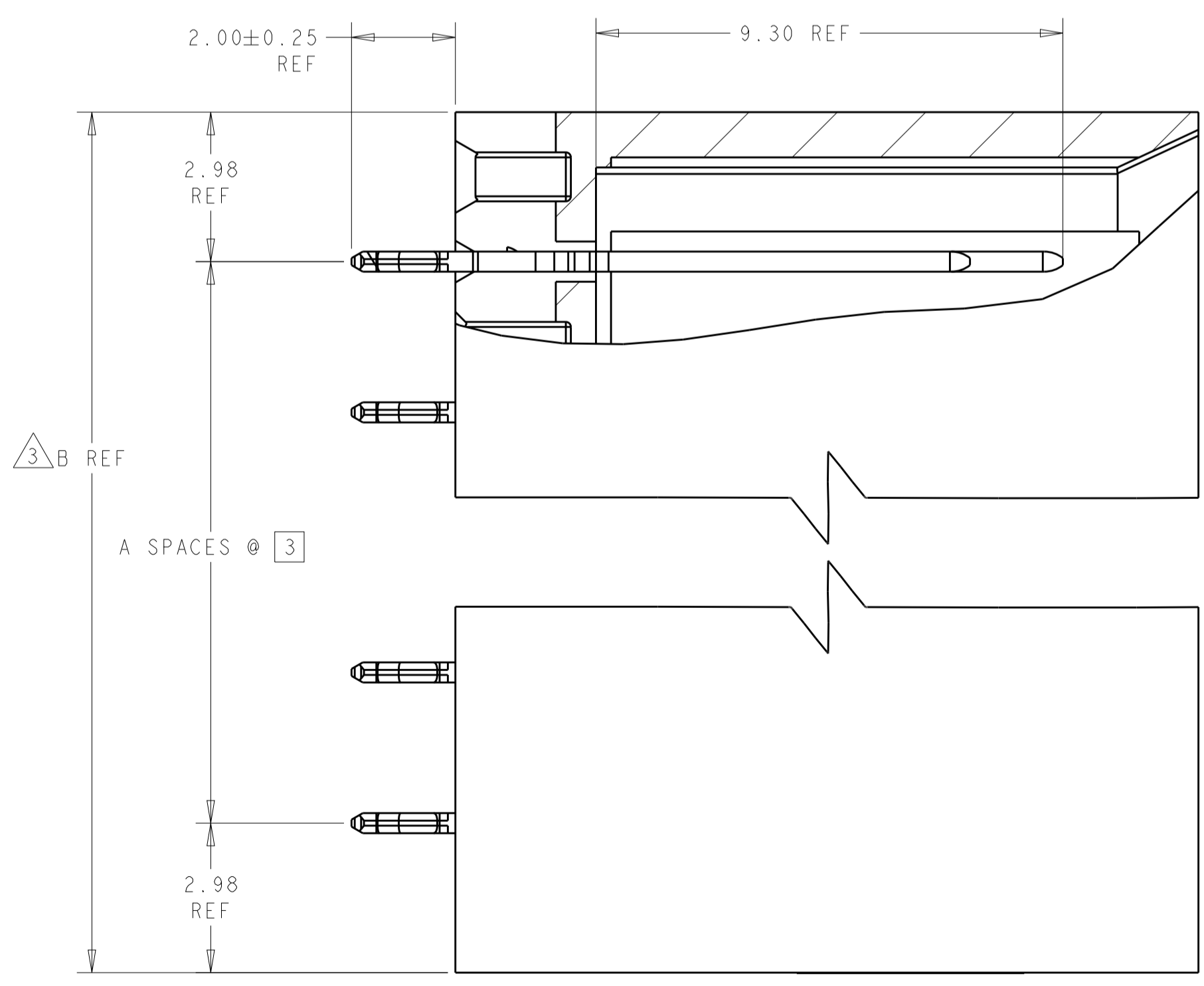
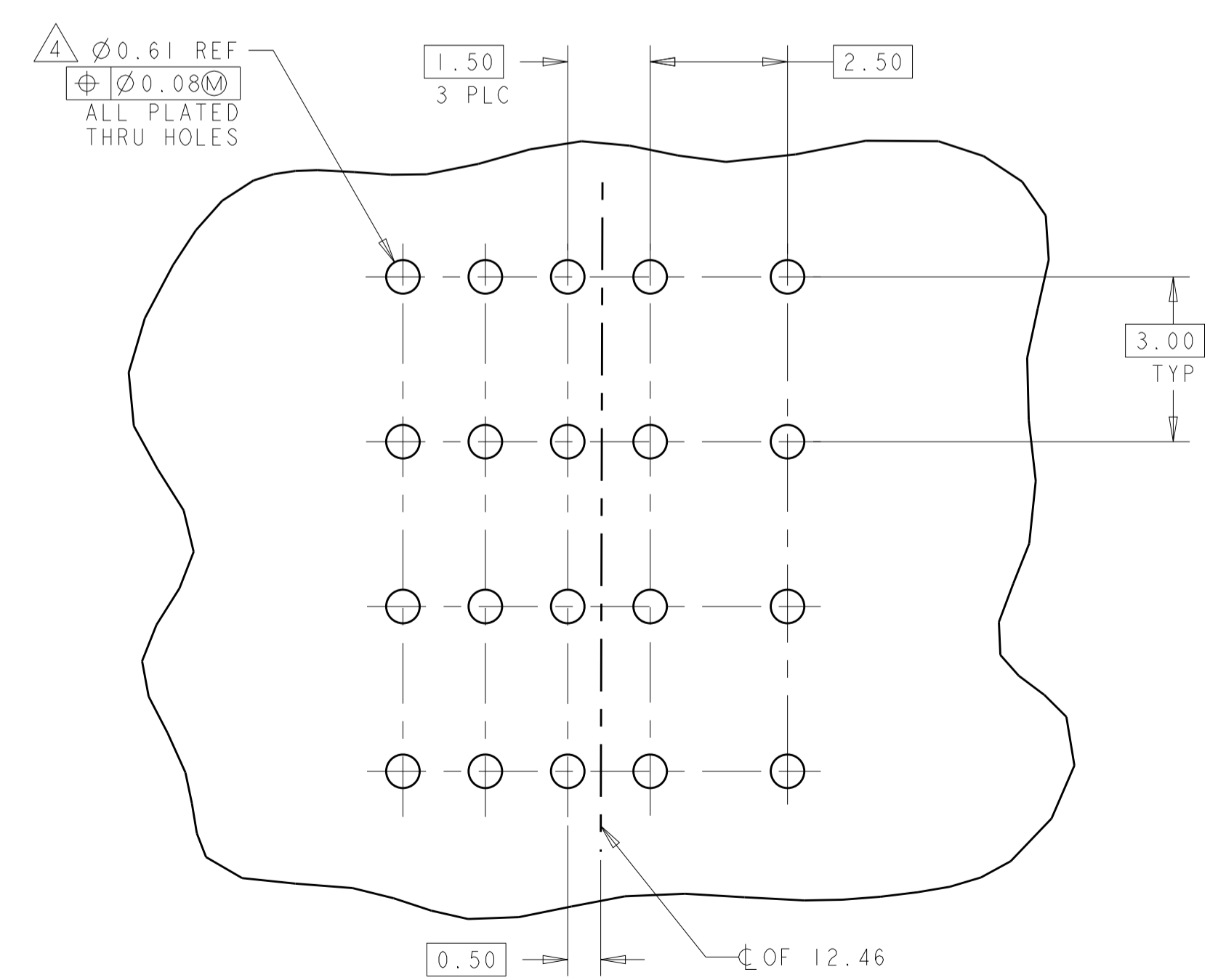
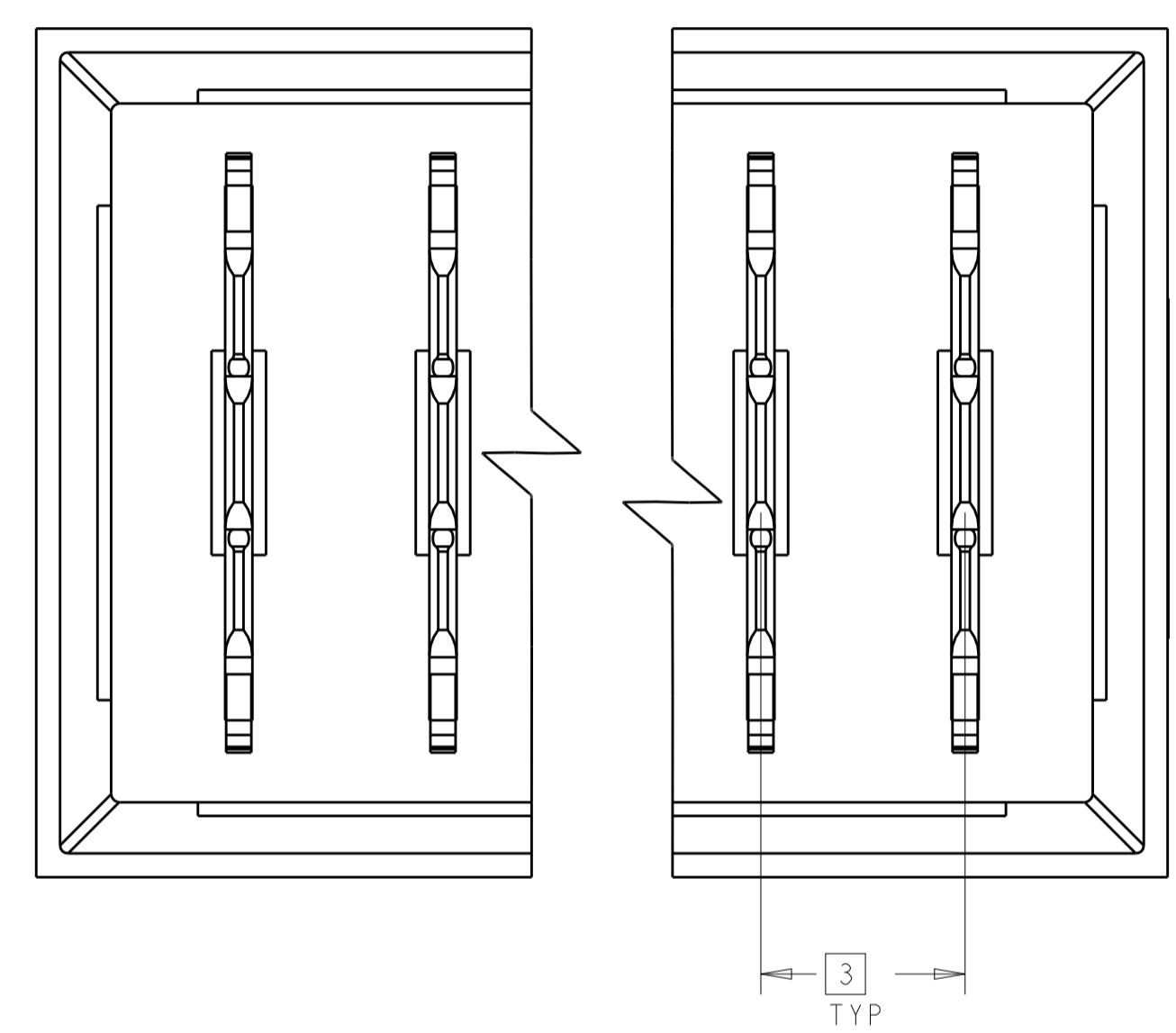
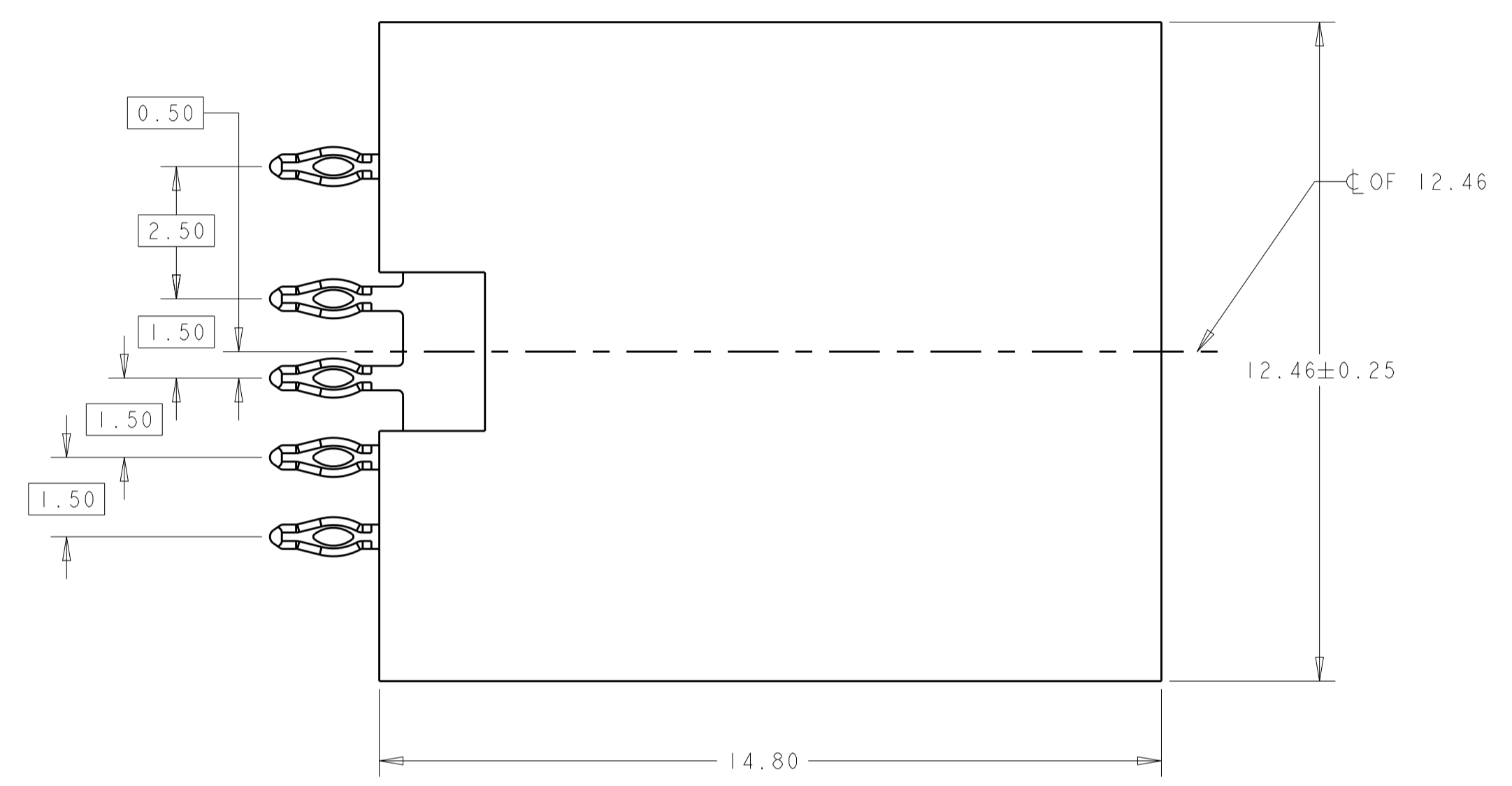

POSITION	B REF	A	PART NUMBER
9	29.95	8	1645498-7
8	26.95	7	1645498-6
7	23.95	6	1645498-5
6	20.95	5	1645498-4
5	17.95	4	1645498-3
4	14.95	3	1645498-2
3	11.95	2	1645498-1

DIMENSIONS: mm 		TOLERANCES UNLESS OTHERWISE SPECIFIED: 0 PLC ± 1 PLC ±0.13 2 PLC ± 3 PLC ± 4 PLC ± ANGLES ±		DWN B. CARBO 18NOV2008 CHK G. GRIFFITH 18NOV2008 APVD G. GRIFFITH 18NOV2008		Tyco Electronics Harrisburg, PA 17105-3608	
MATERIAL 		FINISH 		PRODUCT SPEC 108-1651		NAME UPM VERTICAL HEADER CONNECTOR UNIVERSAL POWER MODULE 15MM STACK HEIGHT	
RESTRICTED CUSTOMER		APPLICATION SPEC 114-1103		SIZE CAGE CODE DRAWING NO A 100779 C=1645498		RESTRICTED TO	
SCALE 10:1		SHEET 1 OF 1		REV B1		Tyco Electronics Harrisburg, PA 17105-3608	