

# PPC. | Clamps, heavy-duty series

pneumatic drive, steel



- 1
- 2
- 3
- 4
- 5
- 6
- 7
- 8
- 9
- 10
- 11
- 12
- 13
- 14
- 15
- 16
- 17
- 18

## MATERIAL

Weldable zinc-plated steel.

## BODY

Black coated spheroidal cast iron.

## HEXAGON-SOCKET HEAD SCREWS WITH COUNTERSINK FOR CYLINDER SUPPORT

Black-oxide steel.

## CYLINDER SUPPORT BUSHINGS

Hardened steel.

## ROTATING PINS AND SEEGER RINGS

Ground and hardened steel.

## MAXIMUM WORKING PRESSURE

6 bars.

## MAX WORKING TEMPERATURE

80°C.

## FEATURES AND APPLICATIONS

All articulated joints are lubricated with special grease. PPC. pneumatic clamps are designed for easy disassembly. Indeed, rotation pins are fixed through seeger rings, which allows to disassemble and change the clamping lever to satisfy specific application requirements.

The magnetic cylinder, equipped with limit switches type PSW. (see page 1660) (to be ordered separately) gives drive and/or control impulses while active.

Using a lubrication filter assembly is necessary for the cylinder to work properly for a long time, whereas flow regulators are recommended to guarantee long life of mechanical components.

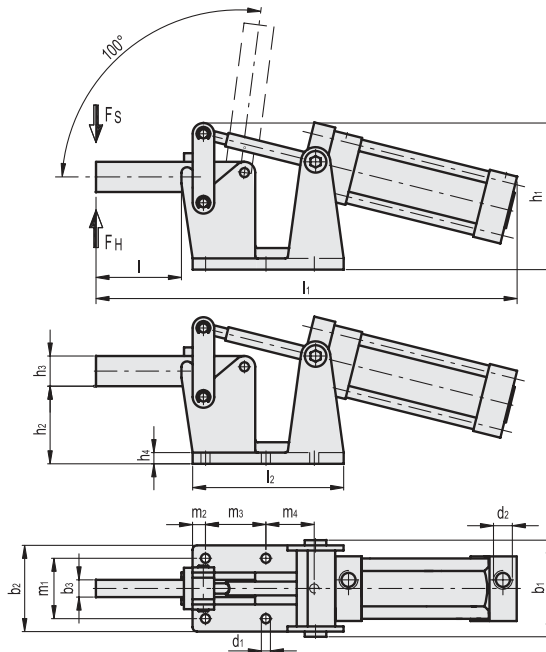
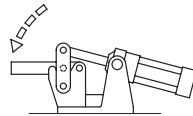

METRIC

Code	Description	b1	b2	b3	d1	d2	h1	h2	h3	h4	l	l1	l2	m1	m2	m3	m4	FH [N]*	FS [N]#	
GG.AO600	PPC.1000-EPM	102	90	20	10.5	G1/4	146.5	80	25	13	80	410	155	65	12.5	65	48	10000	3200	6500
GG.AO620	PPC.2000-EPM	112	100	20	10.5	G3/8	171.5	90	35	13	100	487	176	70	15	70	56	20000	3800	9500

\* Holding force.

# Clamping force ~4 bar

Toggle clamps

1658



Models all rights reserved in accordance with the law. Always mention the source when reproducing our drawings and photos.

