

REV.	DATE	DESCRIPTION
A	03/18/05	UPDATE DRAWING FORMAT

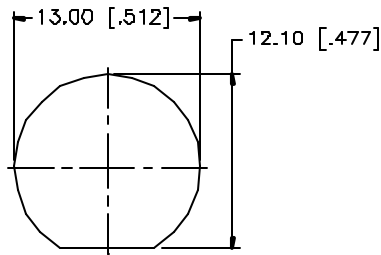

RECOMMENDED MOUNTING HOLE

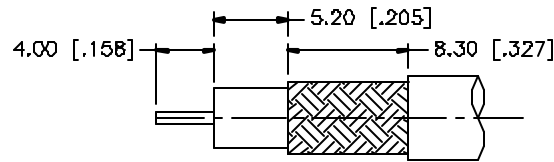

RECOMMENDED CABLE STRIPPING DIM'S

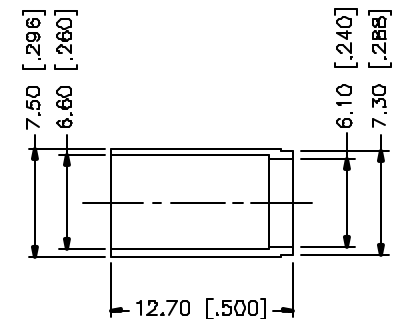
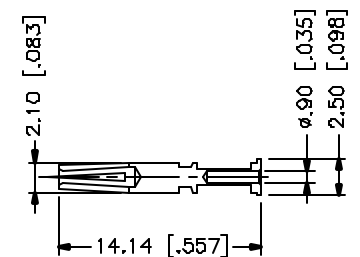
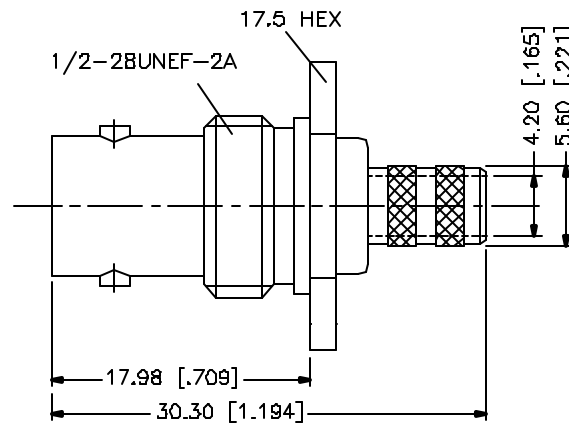
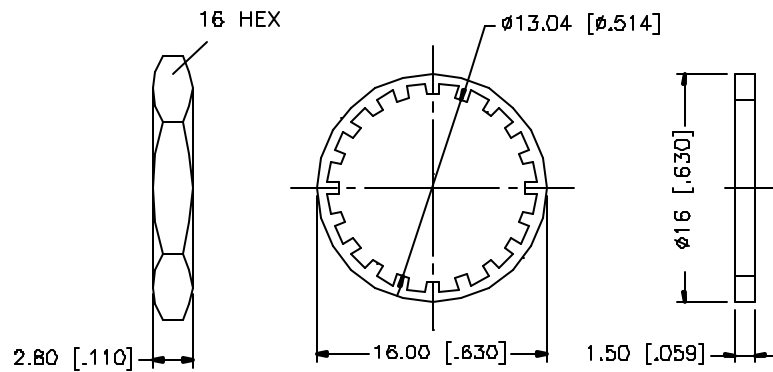

NOTES: FINISH (PLATING THICKNESS IN MICRO-INCHES)

1. NICKEL PL. 100 MIN. OVER COPPER PL. 50 MIN. OVER COPPER PL. 50 MIN.
2. GOLD PL. 30 MIN. OVER NICKEL PL. 50 MIN.
3. TEFLON MIL-P-19468.

B	DESCRIPTION	MATERIAL	FINISH	QTY
7	FERRULE	COPPER	NICKEL	1
6	HEX NUT	BRASS	NICKEL	1
5	LOCK WASHER	BRASS	NICKEL	1
4	GASKET	SILICONE	RED	1
3	CONTACT PIN	PHOS. BRONZE	GOLD	1
2	INSULATOR	TEFLON	NATURAL	1
1	BODY	BRASS	NICKEL	1

UNLESS OTHERWISE SPECIFIED DIMENSIONS ARE IN MILLIMETERS. DIMENSIONS IN [] ARE IN INCHES AND FOR CUSTOMER REFERENCE ONLY.

UNLESS OTHERWISE SPECIFIED TOLERANCES FOR MILLIMETERS ARE:
 0.5 - 30mm ± 0.20mm
 30 - 120mm ± 0.40mm
 120 - 1500mm ± 0.50mm

UNLESS OTHERWISE SPECIFIED TOLERANCES FOR INCHES ARE:
 .020 - .315 = ± 0.007"
 .315 - 1.180 = ± 0.015"
 1.180 - 4.724 = ± 0.020"

DO NOT SCALE DRAWING

APPROVALS	DATE
DRAWN G.R.S.	03/18/05
CHECKED	
ISSUED	
SHEET 1 OF 1	
CAD FILE C:/112/112970.DWG	

Amphenol Connex

PART DESCRIPTION
**BNC BULKHEAD CRIMP JACK
 (FOR AT&T 734A CABLE - 75ohm)**

PART NO. **112970**

DWG. NO.	REV.	SIZE	SCALE
112970.DWG	A	A	NA