

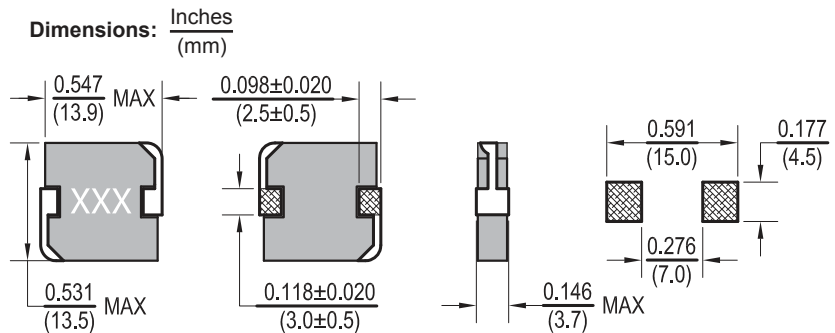

## Power Choke High Current

## PCHC123H



Allied Part Number	Inductance (μh)	Tolerance (%)	Test Freq. KHz, 1v	DCR (mΩ) Max	Isat (A)	Irms (A) Max.
PCHC123H-R47M-RC	0.47	20	100	2	44	32
PCHC123H-R68M-RC	0.68	20	100	2.5	40	28
PCHC123H-1R0M-RC	1.00	20	100	3.5	36	24
PCHC123H-1R5M-RC	1.50	20	100	5.5	28	19
PCHC123H-2R2M-RC	2.20	20	100	8	20	16
PCHC123H-3R3M-RC	3.30	20	100	12	18	12
PCHC123H-4R7M-RC	4.70	20	100	15	16	10
PCHC123H-6R8M-RC	6.80	20	100	22	13	9
PCHC123H-100M-RC	10	20	100	34	9.5	7

All specifications subject to change without notice.

#### Schematic

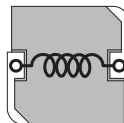

#### Features

- Magnetically shielded construction
- High saturation current up to 44A
- Expanded operating temp range
- Low DCR
- Suitable for pick and place

#### Electrical

**Inductance Range:** .47μH to 10μH

Additional values available

**Tolerance:** 20% over entire range, Available in tighter tolerances

**Test Frequency:** 100KHz, 1V

**Operating Temp:** -40°C ~ +125°C

**Irms:** Current at which ΔT=40°C temp rise with out core loss.

**Isat:** Current at which Inductance drop is approximately 30%.

#### Resistance to Soldering Heat

Pre-Heat 150°C, 1 minute.

**Solder Composition:** Sn/Ag3.0/Cu0.5

**Solder Temp:** 260°C ± 5°C

**Immersion Time:** 10 sec. ± 1 sec.

#### Test Equipment

(L): HP4284A LCR meter or equivalent

**DCR:** CH16502, Agilent 33420A Micro-Ohm meter

**IDC:** 3260B WK & DC Bias 3265B WK

#### Physical

**Packaging:** 600 pieces per 13 inch reel.

**Marking:** EIA Inductance Code