

Safety Precautions

- Important Notes on exporting this product or equipment containing this product;
If the end-user or application of this product is related to military affairs or weapons, its export may be controlled by "Foreign Exchange and Foreign Trade Control Law" of Japan where export license will be required before product can be exported from Japan.
- This product is designed and manufactured for use in General Purpose Industrial Equipment and it is not intended to be used in equipment or system that may cause personal injury or death.
- All servicing such as installation, wiring, operation, maintenance and etc., should be performed by qualified personnel only.
- Tighten mounting screws with an adequate torque by taking into consideration strength of the screws and the characteristics of material to which the product will be mounted. Over tightening can damage the screw and/or material; under tightening can result in loosening.
- Install safety equipment to prevent serious accidents or loss that is expected in case of failure of this product.
- Consult us before using this product under such special conditions and environments as nuclear energy control, aerospace, transportation, medical equipment, various safety equipments or equipments which require a lesser air contamination.
- We have been making the best effort to ensure the highest quality of our products, however, some applications with exceptionally large external noise disturbance and static electricity, or failure in input power, wiring and components may result in unexpected action. It is highly recommended that you make a fail-safe design and secure the safety in the operative range.
- If the motor shaft is not electrically grounded, it may cause an electrolytic corrosion to the bearing, depending on the condition of the machine and its mounting environment, and may result in the bearing noise. Checking and verification by customer is required.
- Failure of this product depending on its content may generate smoke of about one cigarette. Take this into consideration when the application of the machine is clean room related.
- Please be careful when using the product in an environment with high concentrations of sulfur or sulfuric gases, as sulfuration can lead to disconnection from the chip resistor or a poor contact connection.
- Do not input a supply voltage which significantly exceeds the rated range to the power supply of this product. Failure to heed this caution may lead to damage of the internal parts, causing smoke and/or fire and other troubles.
- The user is responsible for matching between machine and components in terms of configuration, dimensions, life expectancy, characteristics, when installing the machine or changing specification of the machine. The user is also responsible for complying with applicable laws and regulations.
- Manufacturer's warranty will be invalid if the product has been used outside its stated specifications.
- Component parts are subject to minor change to improve performance.
- Read and observe the instruction manual to ensure correct use of the product.

Repair

Consult to the dealer from whom you have purchased this product for details of repair work.
When the product is incorporated to the machine you have purchased, consult to the machine manufacturer or its dealer.

URL

Electronic data of this product (Instruction Manual, CAD data) can be downloaded from the following web site;
industrial.panasonic.com/ac/e/

● Contact to : _____

Panasonic Corporation,
Industrial Device Business Division
1-1 Morofuku 7-chome, Daito, Osaka 574-0044, Japan
©Panasonic Corporation 2015
The contents of this catalog apply to the products as of April 2015.

Brushless Motor <MINAS-BL GV series / KV series / GP series>



BRUSHLESS MOTOR

GV series
MINAS-BL KV series
GP series

2015 / 4

Compact and high-efficiency brushless motors

High-efficiency energy saving eco-friendly MINAS series* technology adopted more compact and higher-output brushless motors.

* MINAS series is a registered trademark for Panasonic AC servo motors.



•90 mm square 130 W



•60 mm square 200 W



•80 mm square 50 W

MINAS-BL **GV** series
Speed Control Type 50 W to 130 W

MINAS-BL **KV** series
Speed Control Type 50 W to 750 W

MINAS-BL **GP** series
Position Control Type 50 W to 130 W

Typical options



Console A Digital key pad

Power Supply DC 24 V Type
•80 mm square 50 W only



GV series, input voltage 24 V type made to order item. Please contact us if you'd like detailed information

Typical options



Console A Digital key pad

Typical options



Digital key pad

MINAS-BL

Contents

Introduction	1
GV series	10
Check the model number	11
Brushless motor specifications	11
Brushless amplifier specifications	12
System configuration/ System configuration diagram	13
Parameter list of brushless amplifier	15
Brushless motors – Details	17
Gear head	23
KV series	26
Check the model number	27
Brushless motor specifications	27
Brushless amplifier specifications	28
System configuration/ System configuration diagram	29
Parameter list of brushless amplifier	33
Brushless motors – Details	35
GP series	46
Check the model number	47
Brushless motor specifications	47
Brushless amplifier specifications	48
System configuration/ System configuration diagram	49
Parameter list of brushless amplifie	51
Example setting of motion pattern	53
Brushless motors – Details	57
Gear head	63
Options	66
Options – Details	67
List of peripheral equipments	75
Information	76
Guide to the international system of units (SI)	77
Selecting motor capacity	79
Conformance to international safety standards	93
Table of part numbers and options	95
Index	97
Sales office	101

Motor Business coexisting

with Global Environment

Panasonic Corporation, Automotive & Industrial Systems Company, Smart Factory Solutions Business Division, Motor Business Unit promotes preservation of the environment together with industrial activities and aims to “Company Coexisting with Global Environment”

Basic attitude

Based on “Environmental Declaration” of Panasonic, Smart Factory Solutions Business Division, Motor Business Unit of Automotive & Industrial Systems Company also established the “Environmental Policy” as the basic attitude to environmental conservation. Based on this, we create more specific policies and manuals, and have been promoting environmental conservation activities.

Environmental Policy

Motor Business Unit of Smart Factory Solutions Business Division of Automotive & Industrial Systems Company of Panasonic Corporation recognizes that the preservation of global environment is the important mission as a good corporate citizen of society. Our philosophy is “Coexisting with the Global Environment”, and run sound business activities harmonized with nature.

Environmental conservation activities in industrial field

Environmental conservation activities have been required widely from home level to company level nowadays, and the role of conservation in the industrial sector has become more important. Total emissions of CO₂ in 2009 in Japan were approximately 1.1 billion tons, out of which 380 million tons belong to factory and industrial field. It has become a huge amount which significantly exceeded transportation and business sectors.

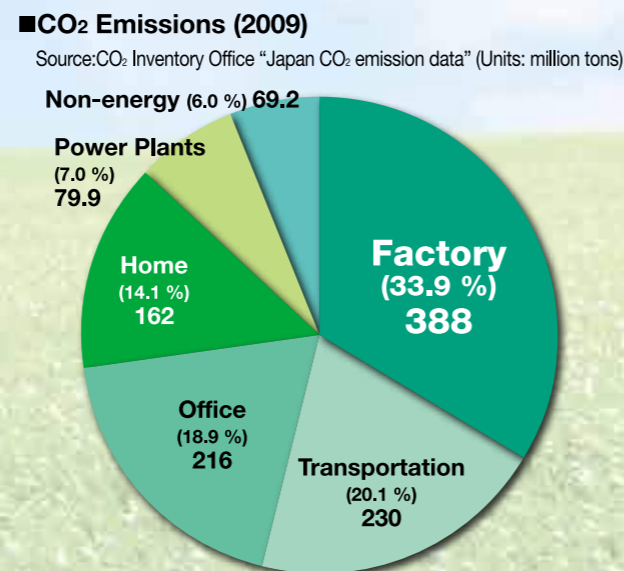

Motor holds the key to global environmental protection

From small one used in mobile phones, to big one used in factories, motor has become indispensable in every aspect of our society. It has been consuming more than half part of electricity in Japan which is equal to 573 billion kWh.

■Japan Domestic electricity consumption (2005)
Source:Motor Business Unit Research (Units: Hundred million kWh)

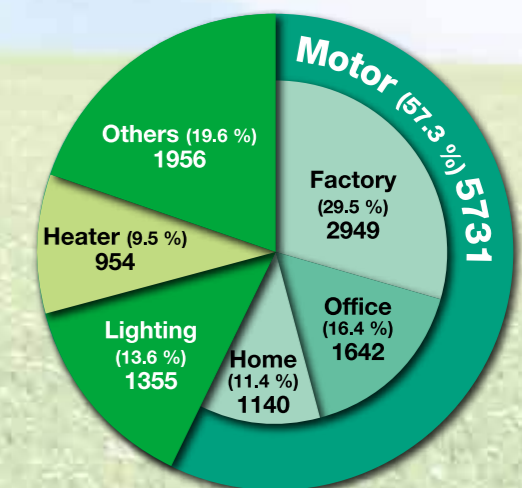

If motor power consumption reduced by 1 % (4.59 billion kWh)



Equivalent to annual one thermal power plant stop (500K kWh×8760h)



With the spread of high-efficiency motors that minimizes the loss of electrical energy, We aim to achieve significant energy savings for the entire industry.



Brushless motors of MINAS-BL series

realize “Three Savings”.

Commutation brushless motor with advanced controlling technology features high efficiency and low power loss.

In addition, “Split Core Structure” developed for and proven in

MINAS series AC servo motors is introduced to these new brushless motors to further reduce their sizes but increase power.

These motors promote “three saving” activities
— Energy saving, Cost saving and Space saving.

Energy Saving

GV KV GP Reduce loss and increase efficiency

A permanent magnet on a rotor reduces secondary loss. It also reduces power consumption by 20 % compared with those of our small geared motors.

■ Comparison of input power with our conventional motors (90 W)

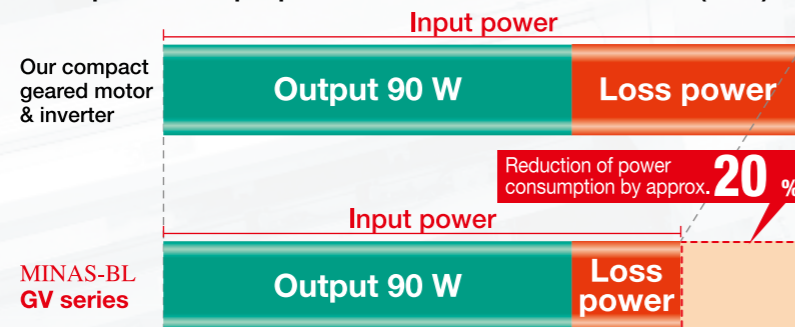

Energy saving effects are significantly seen when these new models are used on multi-axis machines, e.g. textile machinery.

Space Saving



▲ Split core structure

GV KV GP For simultaneous pursuit of miniaturization and high power

“Split core structure” developed for and proven in MINAS series AC servo motors is introduced to these new models to significantly reduce size and weight but increase output power compared with induction motors.

■ Comparison in size between GV/GP series and our compact geared motors (90 W)

Reduction in profile by approx. 55 %

■ Comparison in mass between GV/GP series and our compact geared motors

Lighter by approx. 1/3

Our compact geared motor 90 W (90 mm square)

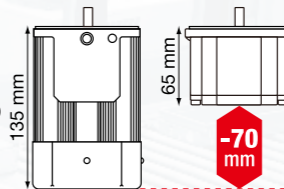

MINAS-BL GV/GP series 90 W (90 mm square)

Output	GV/GP series (motor)	Our compact geared motor
50 W	0.7 kg	2.4 kg(40 W)
90 W	1.0 kg	3.2 kg
130 W	1.2 kg	—

• The size of a GV/GP series brushless amplifier is almost equal to that of a postcard and weights approx. 370 g.

Comparison of KV series with general purpose induction motors: **Approx. 1/7 in volume and approx. 1/4 in mass**

Enable downsizing of embedded device.

Cost Saving

GV KV GP They also reduce maintenance and setup cost.

Commutatorless and brushless design reduces associated costs such as maintenance cost. Our setup support software helps prompt startup and reduction in operation management process.

■ Setup support software PANATERM for BL



▲ Parameter setting
File saving (Batch reading/writing)

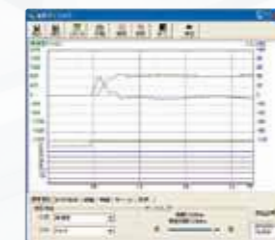

▲ Waveform graphical display
Example: Velocity and torque
Status of I/O can also be monitored.

The PANATERM for BL allows easy setup of parameters. Waveform graphical display can be used for precisely and accurately monitoring motor conditions, reducing setup and maintenance workload.

MINAS-BL series Provide More Features

GV GP

Speed control range **30 r/min ~4000^{*1} r/min**
Proprietary CS sensor for sinewave driving
Wide 1:133 variable speed range

^{*1} Rated rotational speed: 3000 r/min

GV KV GP

Start torque **150 %** (comparison of rated values)
Unlike induction motor
Stable operation startup at lower speed

GV KV GP

Flat torque characteristic

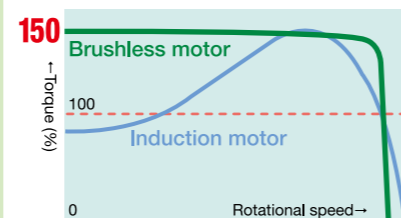

Proprietary CS sensor for **Smooth operation**

GV KV

8-speed operation

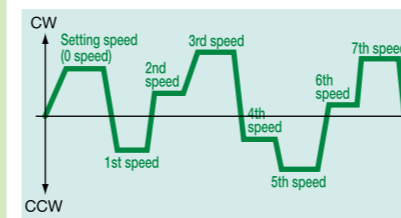

Stable operation maintains high productivity and yield ratio.
The speed is regulated at 0.5 % or less variation.^{*2}

^{*2} Within rated torque

GP

Positioning at 4 points

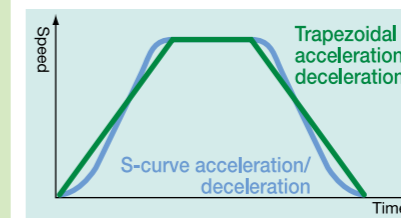

Not only trapezoidal waveform,
S-curve acceleration/deceleration can be set.

GV KV GP

Compatible with international standards



Compatible with wider power source voltage range
(Single-phase: 100 V ~120 V
Single-/Three-phase: 200 V ~240 V)

Speed Control Type

GV series KV series



•90 mm square 130 W

MINAS-BL **GV** series

Speed Control Type 50 W to 130 W



•60 mm square 200 W

MINAS-BL **KV** series

Speed Control Type 50 W to 750 W

- High efficiency brushless motors realize energy saving.
- Distinctively controlled CS signal provides smooth operation through sinewave driving.
- Compatible with international standards (CE, UL, CCC and KC), and wider power source voltage range.
- The digital keypad (sold separately) and setup support software PANATERM for BL (available from our website, free of charge) enable parameter setting and monitoring.
- The proprietary CS sensor extends variable speed control range.
- Installation compatibility:GV series is compatible with our compact geared motors
KV series is compatible with our AC servo motors
- Environmental protection: IP65

Typical applications

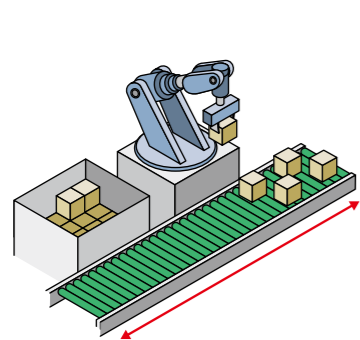

Conveyor

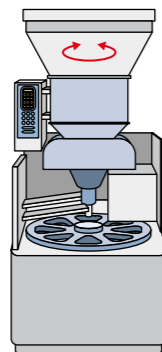

Food processor (agitating)

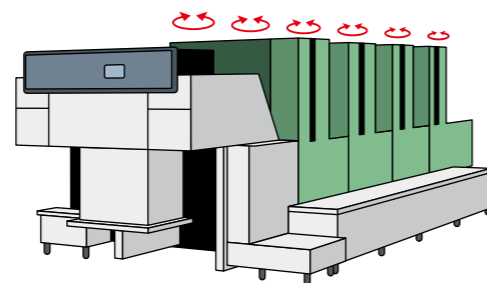

Textile machinery

Position Control Type

GP series



•80 mm square 50 W

MINAS-BL **GP** series

Position Control Type 50 W to 130 W

- Simple NC function enables easier positioning without help of a pulse unit.
- The proprietary CS sensor enables positioning without help of an external encoder.
- Compatible with international standards (CE, UL, CCC and KC), and wider power source voltage range.
- Internal teaching capability simplifies positioning operation.
- The digital keypad (sold separately) and setup support software PANATERM for BL (available from our website, free of charge) enable parameter setting and monitoring.
- Installation is compatible with our compact geared motors.
- Environmental protection: IP65

Typical applications

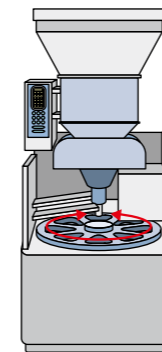

Food processor (turntable)

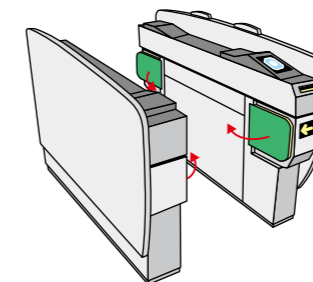

Automatic ticket gate

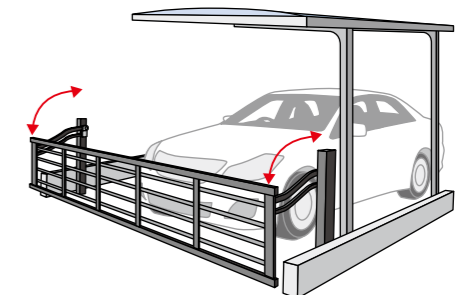

Gate

MINAS-BL **GV** series

Speed Control Type 50 W to 130 W

GV series



• 90 mm square 130 W

Contents	
Check the model number	11
Brushless motor specifications	11
Brushless amplifier specifications	12
System configuration/ System configuration diagram	13
Parameter list of brushless amplifier	15
Brushless motors – Details	17
Gear head	23

Check the model number

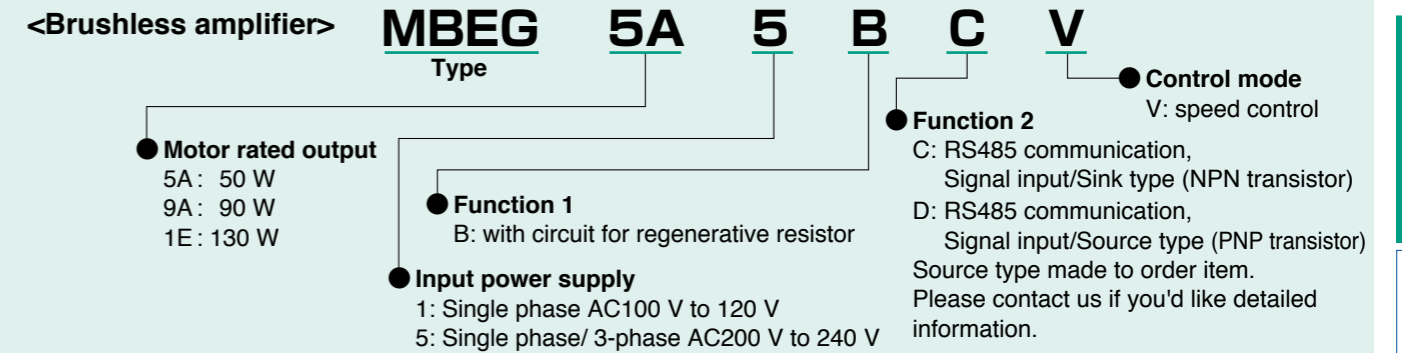
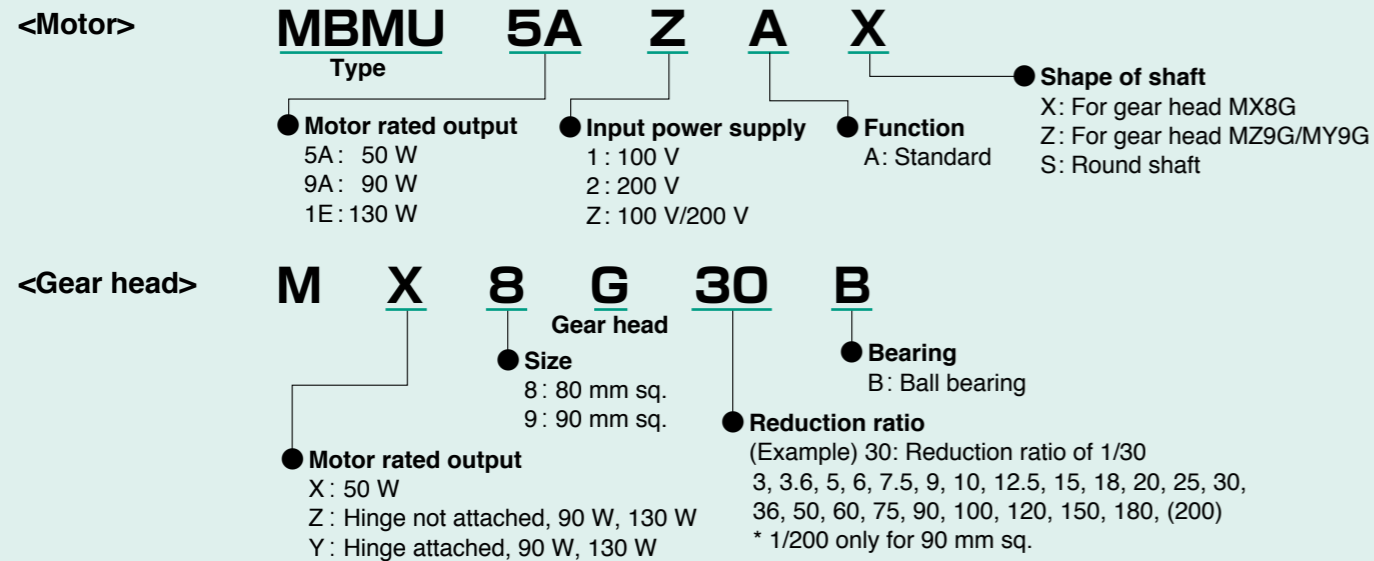

Brushless motor specifications

Item	Specifications				
	80 mm sq.		90 mm sq.		
Flange size	80 mm sq.		90 mm sq.		
Motor model No. *1	MBMU5AZA○	MBMU9A1A○	MBMU9A2A○	MBMU1E1A○	MBMU1E2A○
Motor rated output (W)	50		90		130
Voltage (V)	for 100/200		for 100	for 200	for 100 for 200
Rated torque (N·m)	0.16		0.29		0.41
Starting torque ^{*2} (N·m)	0.24		0.43		0.62
Rated input current (A(rms))	0.53		1.00	0.50	1.30 0.72
Moment of inertia of rotor (×10 ⁻⁴ kg·m ²)	0.12		0.27		0.36
Rating	Continuous				
Rated rotation speed ^{*3} (r/min)	3000				
Speed control range (r/min)	30 to 4000				
Ambient temperature	-10 °C to +40 °C (free from freezing) * Ambient temperature is measured at a distance of 5 cm from the motor.				
Ambient humidity	20 % to 85 % RH (free from condensation)				
Altitude	Lower than 1000 m				
Vibration	4.9 m/s ² or less X, Y, Z				
Motor insulation class	130(B) (UL certified 105 (A))				
Protection structure	IP65 ^{*4,5}				
Number of poles	8				
Motor mass (kg)	0.7	1.0		1.2	

*1 Suffix of "○" in the motor model represents shape of shaft.

*2 Representative value

*3 Motor shaft speed: to be multiplied by the reduction ratio when the gear head is used.

*4 Excluding the shaft pass-through section and cable end connector.

*5 These motors conform to the test conditions specified in EN standards (EN60529, EN60034-5).

Do not use these motors in application where water proof performance is required such as continuous wash-down operation.

Overload protection characteristics

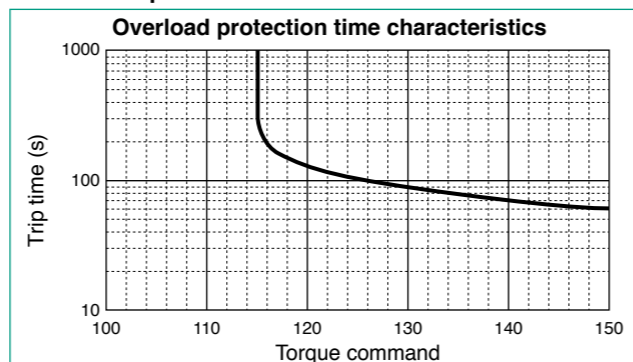

Brushless amplifier specifications (GV series)

Item	Specifications								
	MBEG5A1BCV	MBEG5A5BCV	MBEG9A1BCV	MBEG9A5BCV	MBEG1E1BCV	MBEG1E5BCV			
Amplifier model No.	MBMU5AZA○		MBMU9A1A○		MBMU9A2A○		MBMU1E1A○ MBMU1E2A○		
Applicable Motor *1	MBMU5AZA○		MBMU9A1A○		MBMU9A2A○		MBMU1E1A○ MBMU1E2A○		
Motor rated output (W)	50			90			130		
Input power supply voltage (V)	Single phase 100 to 120	Single phase 200 to 240	3-phase 200 to 240	Single phase 100 to 120	Single phase 200 to 240	3-phase 200 to 240	Single phase 100 to 120	Single phase 200 to 240	3-phase 200 to 240
Frequency (Hz)	50/60								
Rated input current (A)	1.5	0.7	0.35	2.2	1.1	0.5	2.8	1.5	0.7
Voltage tolerance	±10 %								
Control method	Speed control by CS signal, PWM sine wave driving system								
Ambient temperature	0 °C to +50 °C (free from freezing) * Ambient temperature is measured at a distance of 5 cm from the amplifier.								
Ambient humidity	20 % to 85 % RH (free from condensation)								
Location	Indoor (No corrosive gas, A place without garbage, and dust)								
Altitude	Lower than 1000 m								
Vibration	5.9 m/s ² or less (10 Hz to 60 Hz)								
Protection structure/ Cooling system	Equivalent to IP20/ Self cooling								
Storage temperature	Normal temperature * Temperature which is acceptable for a short time, such as during transportation is -20 °C to 60 °C (free from freezing)								
Storage humidity	Normal humidity								
Rated rotation speed	3000 r/min								
Speed control range	30 r/min to 4000 r/min (Speed ratio 1:133)								
Speed fluctuation factor	With load		±0.5 % or below (at 0 to Rated torque, Rated rotation speed)						
	With voltage		±0.5 % or below (at supply voltage ±10 %, rated rotation speed)						
	With temperature		±0.5 % or below (at 0 °C to 50 °C, rated rotation speed)						
Acceleration/ Deceleration time	0.01 sec to 300 sec (time for changing 1000 r/min) ^{*2}								
Stopping procedure	Slowdown stop/ Free-run stop ^{*2}								
Speed setting	0 r/min to 4000 r/min (analogue voltage (0 V to 5 V), console A), 0 r/min to 4000 r/min (Setting selection by parameter on Digital key pad)								
Speed setting resolution	Analog: approx. 1/200 of upper speed limit Digital: 1 r/min								
Speed setting precision (at 20 °C)	Analog: ±3 % or below of upper speed limit (±90 r/min or below at upper speed limit 3000 r/min) [Digital: 1 % or below of upper speed limit]								
Operation mode	8 speed								
Signal input	5 inputs ^{*2} (run/ stop, CW run/ CCW run, multi function 3bit)								
Signal output	2 outputs (Open collector) ^{*2} (Trip output etc)								
Communication function	RS485	Max 31 units. Setting of parameter, monitoring of control condition. Communication speed: Choose from 2400 bps/ 4800 bps/ 9600 bps							
	RS232	Setting of parameter and monitoring of control condition are enabled with commercial PC. ^{*3}							
Digital key pad	Setting of parameter, monitoring of control condition. ^{*4}								
Protective function	Warning : Undervoltage ^{*2} , Overload warning, setting change warning Protect : Undervoltage ^{*2} , Overload, Overcurrent, Overvoltage, Overheat, Overspeed, Sensor error, RS485 communication error, External forced trip error, User parameter error, CPU error								
Regenerative brake	Regenerative braking resistor can be externally connected. ^{*5} Instantaneous braking torque 200 %, Continuous regenerative ability of external regenerative resistor: 10 W (Regenerative operation with which motor shaft is rotated by load, e.g. load lowering operation, should not be continued.)								
Protection level	Protection level: torque command 115 (inverse time characteristics)								
Amplifier mass (kg)	0.37								

*1 Suffix of "○" in the motor model represents shape of shaft. *2 Can be changed from PANATERM for BL or Digital key pad.

*3 PANATERM for BL (Download from our web site.), PC connection cable (DV0P4140), Digital key pad connection cable (DV0P383*0) is required. If your PC does not have RS232 port, use RS232-USB converter.

*4 Digital key pad connection cable (DV0P383*0) is required. *5 Use optional external regenerative resistor (sold separately).

System configuration

Power supply	Rated rotation speed (r/min)	output (W)	Motor	Gear head (Note 1)	Brushless amplifier	Optional parts				
						Brushless amplifier (supplied with power cable) (Note 2)	External regenerative resistor	Noise filter	Surge absorber	Reactor
						Reference page p. 74	p. 71	p. 67	p. 67	p. 73
Single phase 100 V	3000	50	MBMU5AZAX	MX8G□B	MBEG5A1BCV	MBEG5A1BCVC	for 100 V DV0P2890	for single phase power supply DV0P4170	for single phase power supply DV0P4190	for single phase power supply DV0P227
			MBMU5AZAS	—						
		90	MBMU9A1AZ	MZ9G□B MY9G□B	MBEG9A1BCV	MBEG9A1BCVC				
			MBMU9A1AS	—						
		130	MBMU1E1AZ	MZ9G□B MY9G□B	MBEG1E1BCV	MBEG1E1BCVC				
			MBMU1E1AS	—						
Single/3-phase 200 V	3000	50	MBMU5AZAX	MX8G□B	MBEG5A5BCV	MBEG5A5BCVC	for 200 V DV0PM20068	for single phase power supply DV0P4170 for 3-phase power supply DV0PM20042	for single phase power supply DV0P4190	for 3-phase power supply DV0P227 for 3-phase power supply DV0P220
			MBMU5AZAS	—						
		90	MBMU9A2AZ	MZ9G□B MY9G□B	MBEG9A5BCV	MBEG9A5BCVC				
			MBMU9A2AS	—						
		130	MBMU1E2AZ	MZ9G□B MY9G□B	MBEG1E5BCV	MBEG1E5BCVC				
			MBMU1E2AS	—						

(Note 1) A figure representing reduction ratio in □.

(Note 2) Refer to p. 74 for a power supply connecting cable.

This part number is the ordering part number for the amplifier and power cable, not for ordering amplifier only.

The supplied power connecting cable is for single-phase input, when supplying three-phase power; please make a cable using optional power connection kit (DV0P2870).

* When installing the reactor, refer to p. 73.

* **Be sure to use a set of matched components (series, power source, capacity, output, etc.)**

* **This motor is not provided with a holding brake. If it is used to drive a vertical shaft, the movable section may fall down by its own weight as power is turned off.**

Options

Optional parts	Parts number	Reference page	Optional parts	Parts number	Reference page	
Motor extension cable	1 m	DV0PQ1000110	Digital key pad connection cable	1 m	DV0P38310	
	3 m	DV0PQ1000130		3 m	DV0P38330	
	5 m	DV0PQ1000150		5 m	DV0P38350	
	10 m	DV0PQ10001A1				
Power supply connector kit	DV0P2870	P.70	External speed setter	DV0PM20078	P.71	
Console A ¹	DV0P3500	P.68	Control signal cable	2 m	DV0PM20076	P.70
Console A connection cable	1 m	DV0PM2006910	I/O connector kit	DV0PM20070	P.71	
	3 m	DV0PM2006930	Panel connector kit	DV0P3610	P.71	
	5 m	DV0PM2006950	PC connection cable ³	1.5 m	DV0P4140	P.70
Digital key pad ²	DV0P3510	P.68	Noise filter for signal line	DV0P1460	P.67	
			DIN rail mounting unit	DV0P3811	P.72	

* For details of cable, refer to p. 68 to p. 70.

*1 When using Console A, the Console A connection cable (DV0PM20069*0) is required.

*2 When using Digital key pad, the Digital key pad connection cable (DV0P383*0) is required.

*3 When connecting PC, the PC connection cable (DV0P4140) and the Digital key pad connection cable (DV0P383*0) are required.

Wiring equipment

Selection of circuit breaker (MCCB), magnetic contactor and electric wire. (To check conformity with international standards, refer to p. 93 Conformity with international safety standards.)

Voltage	Power capacity	MCCB Rated current	Magnetic contactor Rated Current (Contact composition)	Core of electric wire (mm ²)	
				Main circuit, Grounding	Control circuit
Single phase 100 V	50 W to 130 W	5 A	20 A (3P+1a)	0.5 (AWG20)	0.13 (AWG26)
Single phase 200 V					
3-phase 200 V					

■ **Be sure to connect the earth terminal to ground.**

In wiring to power supply (outside of equipment) from MCCB, use an electric wire of 1.6 mm diameter (2.0 mm²) or more both for main circuit and grounding. Apply grounding class D (100 Ω or below) for grounding.

Selection of relay

A relay used in a control circuit, e.g. at the control input terminal should be small signal relay (Min. guaranteed current 1 mA or less) for positive contact. <Example> Panasonic: DS type, HC type OMRON: G2A type

Selection of control circuit switch

When using a switch in place of relay, select a switch rated at minute electric current, to assure positive contact.

<Example> Nihon Kaiheiki Ind.: M-2012J-G

The wiring of SER and I/O connector

The wiring of SER and I/O connector should separate from power line to prevent malfunction.

Wiring to the I/O connector

Permissible length for control signal cable is 5 m or less.

System configuration diagram

Example of analog setting (Console A)

- Set the speed with the speed setting knob (variable resistor).
- Start/stop the motor from the RUN/STOP switch.
- To change rotating direction, use the rotation direction selector switch.

When not using Console A

Motor controls such as start/stop, direction change and speed setting can be done from external potentiometer and switch through optional control signal cable or I/O connector kit.

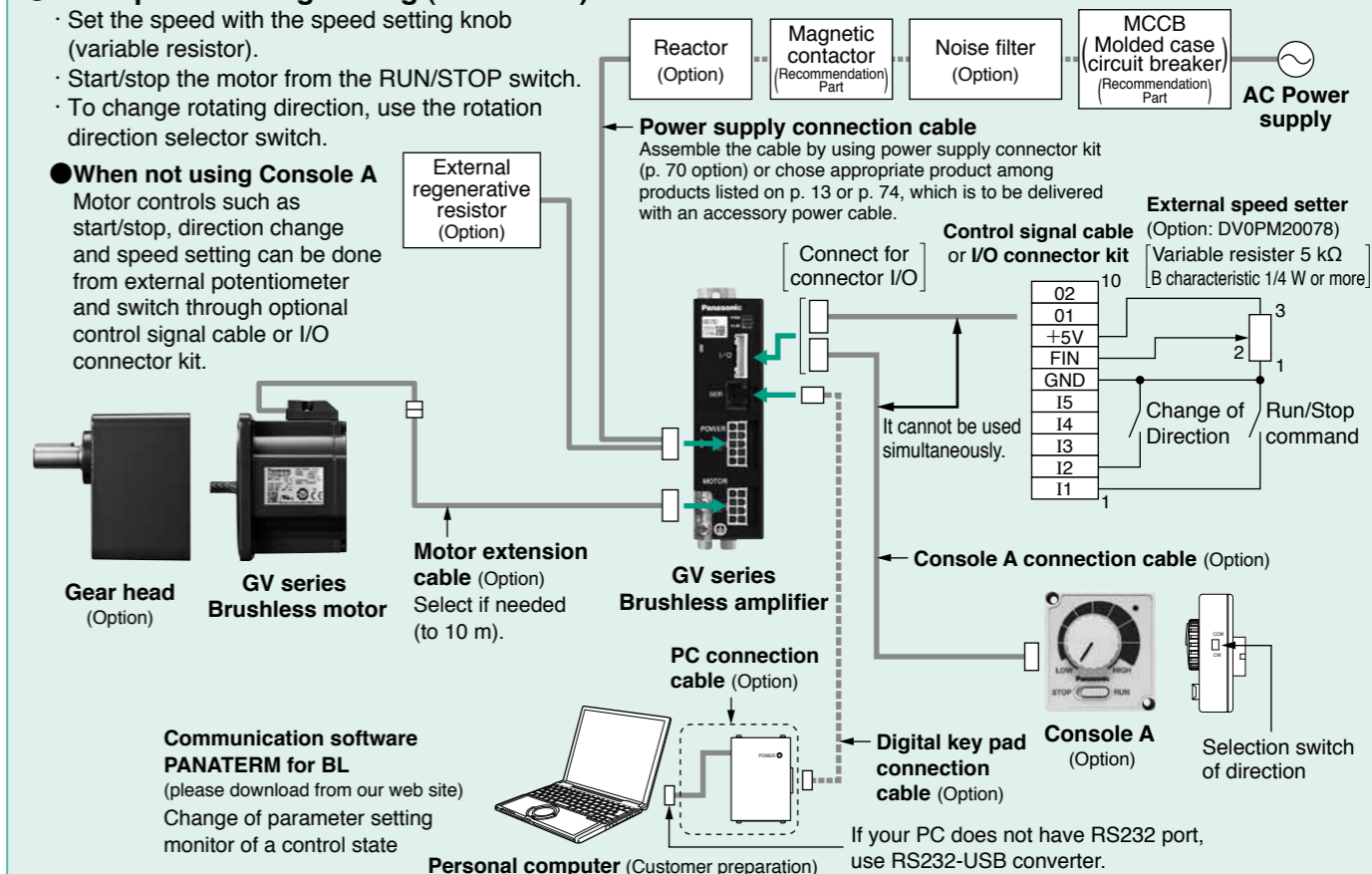

Example of digital setting (Digital key pad)

- To start/stop the motor, use RUN/STOP key
- Digital monitor [Rotation speed, Commanded speed, Internal DC voltage, Load factor, Torque, Trip history, Overload warning (flashing)]
- Set/change parameters
- Storage of the parameters (read, write)

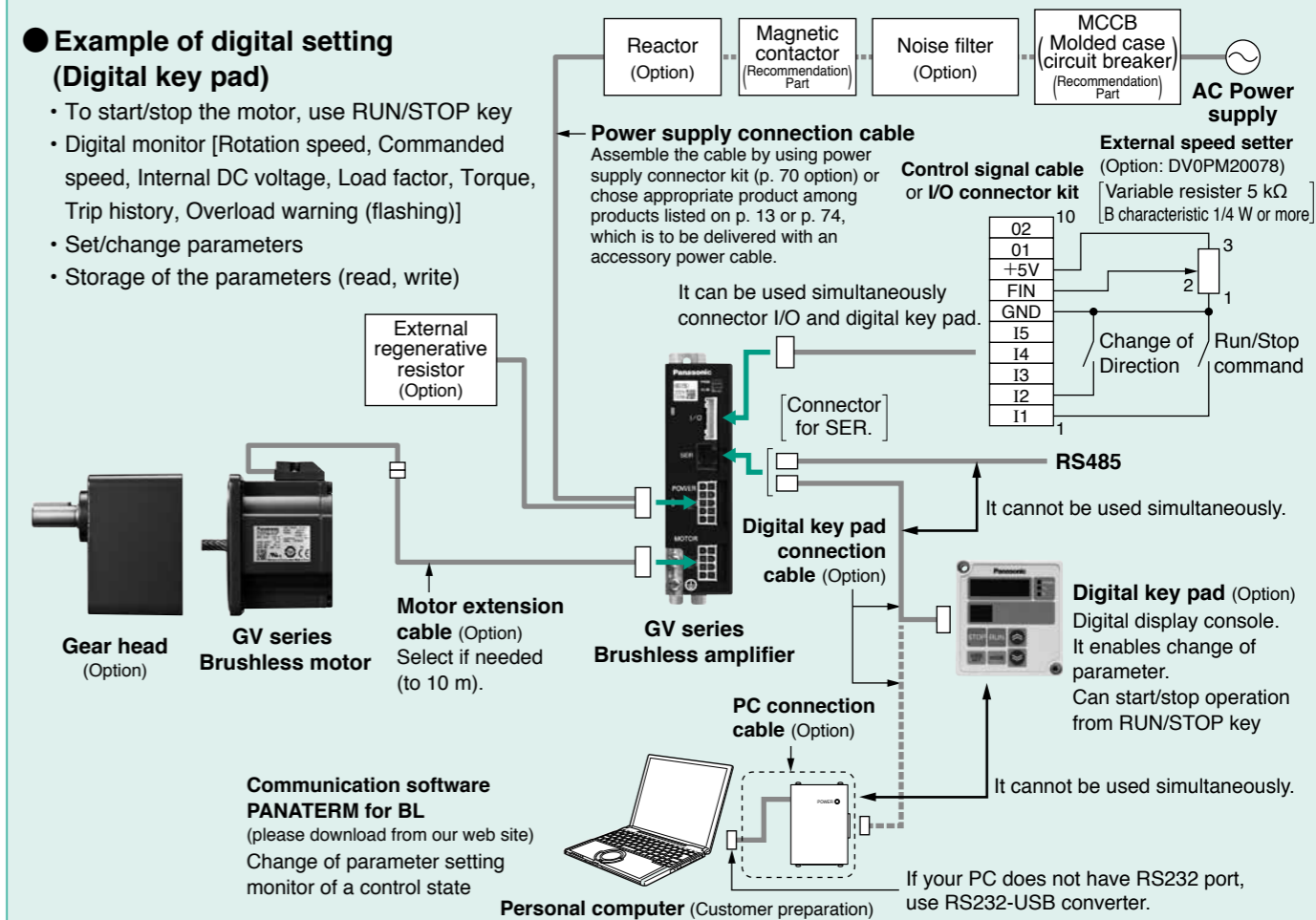

Parameter list of brushless amplifier

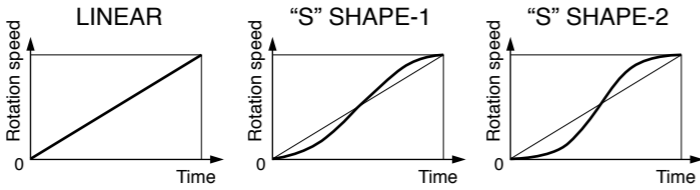
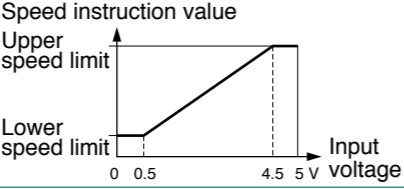
Parameter No.	Parameter name	Explanation	Setting range																												
00	Internal speed (0-th speed)	Desired running speed can be set with the Digital key pad.	0 r/min to Upper speed limit [Minimum unit 1 r/min]																												
01 to 07	1st speed to 7th speed	Speed in multi-speed running can be set.	0 r/min to Upper speed limit [Minimum unit 1 r/min]																												
10 11	1st acceleration time 2nd acceleration time	The change factor of output speed in acceleration can be determined. Set by time for changing 1000 r/min.	0.01 sec to 300 sec to 3 sec: Incremented by 0.01 second 3 sec to 30 sec: Incremented by 0.1 second 30 sec to 300 sec: Incremented by 1 second																												
12 13	1st deceleration time 2nd deceleration time	The change factor of output speed in deceleration can be determined. Set by time for changing 1000 r/min.																													
14 15	Acceleration mode selection Deceleration mode selection	Straight line acceleration/deceleration and curve (S-shape) acceleration and deceleration can be chosen individually for acceleration and deceleration. 	Select S-shape when "31 Speed command selection" is PnL.																												
16	Stop mode selection	You can select how to stop the motor when stop command is input: free-run stop or stop after deceleration.																													
17	Free-run waiting time	When the stop mode is set to deceleration stop, the zero speed (servo lock time) after deceleration can be adjusted.	0.0 sec to 10.0 sec [Minimum unit 0.1 sec]																												
1A	Velocity loop proportional gain	Enables setting of proportional gain of velocity amplifier.	0 to 10000 [Minimum unit 0.1]																												
1b	Velocity loop integration gain	Enables setting of integration gain of velocity amplifier.	0 to 10000 [Minimum unit 0.1]																												
30	Run command selection	Run command can be applied through: Digital key pad, input terminal "I1", "I2" or RS485 communication, whichever selected.																													
31	Speed command selection	You can choose whether to use "00 Internal speed (0-th speed)" or analog input terminal for speed command.																													
32	Operation mode selection	Parameter for choosing operation mode <table border="1" data-bbox="418 1262 1062 1560"> <thead> <tr> <th rowspan="2">Setting</th> <th rowspan="2">Operation mode</th> <th colspan="3">Function of signal input</th> </tr> <tr> <th>I3</th> <th>I4</th> <th>I5</th> </tr> </thead> <tbody> <tr> <td>1</td> <td>1st speed operation mode</td> <td></td> <td></td> <td>Free-run stop External forced trip</td> </tr> <tr> <td>2</td> <td>2nd speed operation mode</td> <td>Speed setting</td> <td></td> <td>2nd Acc./Dec. time Trip reset</td> </tr> <tr> <td>4</td> <td>4th speed operation mode</td> <td>Speed setting</td> <td>Speed setting</td> <td></td> </tr> <tr> <td>8</td> <td>8th speed operation mode</td> <td>Speed setting</td> <td>Speed setting</td> <td>Speed setting</td> </tr> </tbody> </table>	Setting	Operation mode	Function of signal input			I3	I4	I5	1	1st speed operation mode			Free-run stop External forced trip	2	2nd speed operation mode	Speed setting		2nd Acc./Dec. time Trip reset	4	4th speed operation mode	Speed setting	Speed setting		8	8th speed operation mode	Speed setting	Speed setting	Speed setting	
Setting	Operation mode	Function of signal input																													
		I3	I4	I5																											
1	1st speed operation mode			Free-run stop External forced trip																											
2	2nd speed operation mode	Speed setting		2nd Acc./Dec. time Trip reset																											
4	4th speed operation mode	Speed setting	Speed setting																												
8	8th speed operation mode	Speed setting	Speed setting	Speed setting																											
33 34 35 36	I1/I2 function selection I3 function selection I4 function selection I5 function selection	Signal input functions I1 to I5 can be individually selected.	Free-run stop External forced trip 2nd Acc./Dec. time Trip reset																												
3A	Lower speed limit	When speed command selection is set to analog, set the motor speed at 0 V input. 	0 r/min to Upper speed limit [Minimum unit 1 r/min]																												
3b	Upper speed limit	Upper limit of motor command speed.	0 r/min to 4000 r/min [Minimum unit 1 r/min]																												
3C	Torque limit	Set the upper limit of the output torque command. 100 represents the rated torque.	50 to 150 [Minimum unit 1]																												

Parameter No.	Parameter name	Explanation	Setting range
40 41	O1 function selection O2 function selection	The type of signals from output terminals "O1" and "O2" can be selected. * Do not use it for position detector and positioning.	Trip: ON, Speed is reached to a command value: ON, Running: ON, Free run: ON, CCW run: ON, CW run: ON, Load exceeds 100 %: ON, Speed pulse signal*
42 43	O1 output polarity selection O2 output polarity selection	This is a function for inverting the polarity of signal output terminal O1 and O2.	
44	Speed matching range	"Matching range" of arriving signal can be adjusted.	20 r/min to Upper speed limit [Minimum unit 1 r/min]
45	Output pulse count selection	Set the number of pulses to be output to output terminals "O1" and "O2". • When you use it in more than 3000 r/min, choose values less than 12. • Do not use "the speed pulse" of the output signal (parameter No.45) for position sensing and a positioning use.	1, 2, 3, 4, 6, 8, 12, 24
46	Monitor mode selection	You can choose description to be displayed on 5-digit LED when turning on power.	Rotation speed, Speed command, Internal DC voltage, Load factor, Torque
47 48	Numerator of display magnification factor Denominator of display magnification factor	By setting the multiplying factor of a value displayed on 5-digit LED, the rotation speed of gear output shaft and conveyor speed can be displayed.	
4A	Trip history clear	Trip history can be cleared.	
4b to 4F	Trip history 1 to Trip history 5	Trip history for 5 times in the past is stored.	
50	Undervoltage trip selection	You can select whether tripping occurs upon detection of undervoltage.	
51	Retrial selection	Automatic reset in trip (trip retrial) can be set here.	
52	Retrial start time	You can set waiting time until retrial operation is performed after tripping is found.	1 sec to 120 sec [Minimum unit 1 sec]
54	Parameter initializing	Parameters can be initialized to the factory default.	
57	Parameter copy	Parameters can be copied.	
5A	RS485 device number	Set the device number of Amplifier in communication (Amplifier ID)	
5b	RS485 communication speed	Set the communication speed of RS485 communication.	
5C	RS485 communication standard	Set the communication standard of RS485 communication.	
5d	RS485 communication response time	You can set the shortest time necessary to set the RS485 bus to transmission mode to response upon receiving communication data.	
5E	RS485 retry times of communication	Set the retry times of RS485 communication.	
5F	RS485 protocol timeout	You can set the permissible time interval between successively received character codes.	

• How to use Digital key pad

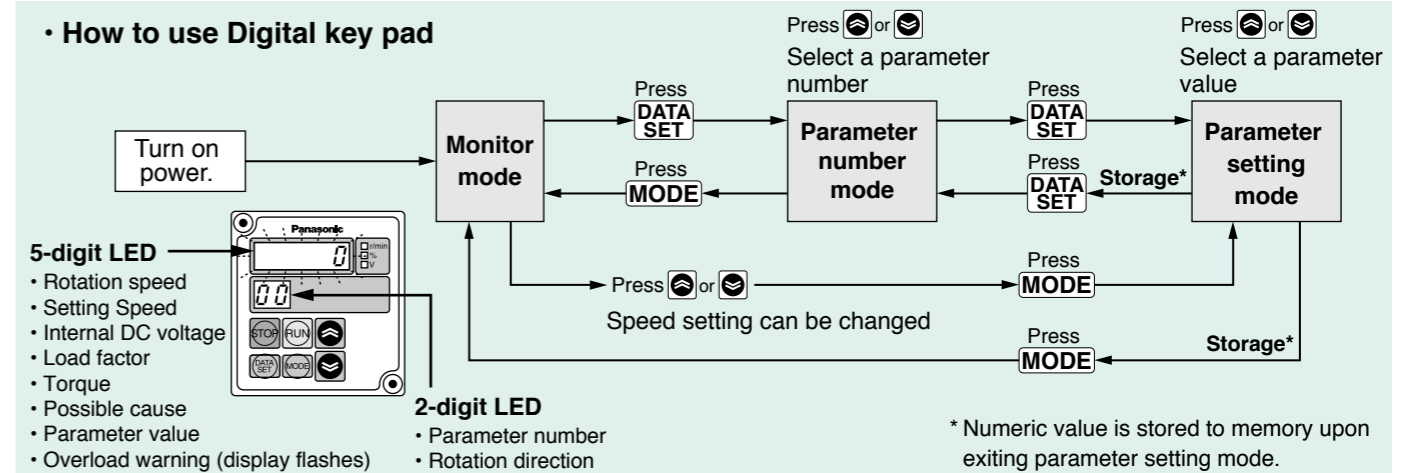

Specification (For Common specification, see p. 11, p. 12)

Size	Model No. / Amplifier and Motor		Rated output (W)	Input power supply for Amplifier			Rated torque (N·m)	Starting torque (N·m)	Rated speed (r/min)	Maximum rotation speed (r/min)	
	Brushless Amplifier Model number in () is shipped with power connection cable	Motor		Voltage AC (V)	Allowed range (%)	Frequency (Hz)					Rated input current (A)
80 mm sq.	MBEG5A1BCV (MBEG5A1BCVC)	MBMU5AZA○	50	Single phase 100 to 120	±10	50/60	1.5	0.16	0.24	3000	4000
	MBEG5A5BCV (MBEG5A5BCVC)	MBMU5AZA○		Single phase / 3-phase 200 to 240			Single phase 0.7 3-phase 0.35				

* Suffix of "○" in the motor model No. represents shape of shaft. Refer to the "Check the model number" p. 11. * Starting torque: Representative value

Permissible torque at output shaft of gear head (N·m)

Applicable Gear head	Reduction ratio	Reduction ratio																							
		3	3.6	5	6	7.5	9	10	12.5	15	18	20	25	30	36	50	60	75	90	100	120	150	180		
MX8G□B	motor rotation speed (r/min)	3000 or less	0.39	0.46	0.64	0.77	0.96	1.16	1.29	1.61	1.92	2.33	2.59	3.23	3.61	4.33	5.93	7.29							7.84
	3000 to 4000	0.29	0.35	0.48	0.58	0.72	0.87	0.97	1.21	1.44	1.75	1.94	2.42	2.71	3.25	4.45	5.47	6.84							7.84
Rotational direction		Same as motor rotational direction												Reverse to motor rotational direction											

Permissible load inertia moment (×10⁻⁴ kg·m²)

Reduction ratio	Reduction ratio																					
	3	3.6	5	6	7.5	9	10	12.5	15	18	20	25	30	36	50	60	75	90	100	120	150	180
Applicable Gear head													342									
MX8G□B	1.25	1.79	3.42	4.90	7.72	11.2	13.8	21.6	30.6	45.2	55.8	86.9	127	183							342	

Permissible shaft load

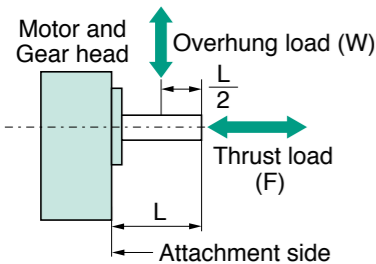

Motor shaft (Round shaft)	Output	Overhung load (W)	Thrust load (F)
	50 W	100 N	10 N
Applicable Gear head	MX8G□B	294 N	49 N

Wiring diagram

In Case of 3-Phase 200 V

* When you use single phase, connect the main power between L1 and L2 terminals.

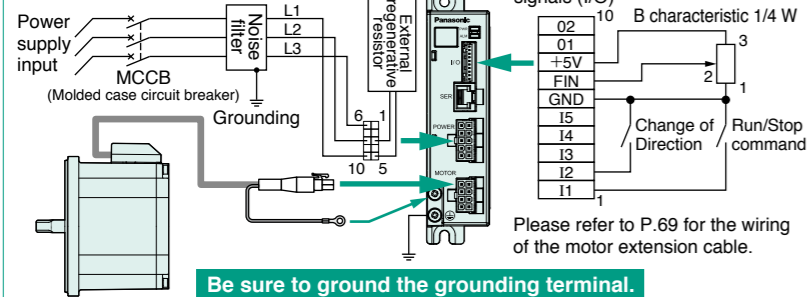

Be sure to ground the grounding terminal.

In wiring to power supply (outside of equipment) from MCCB, use an electric wire of 1.6 mm diameter (2.0 mm²) or more both for main circuit and grounding. Apply grounding class D (100 Ω or below) for grounding. Do not tighten the ground wires together, but connect them individually.

* Please refer to P.95 Support option.

* Before using, be sure to read "Instruction manual" to check precautions and correct procedure.

Speed-torque characteristic (Dotted line shows a characteristic curve when supply voltage drops by 10 %)

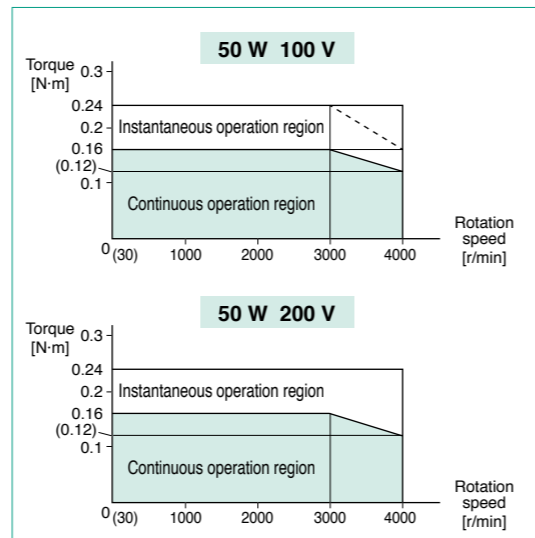

Motor (dimensions)

Unit mm

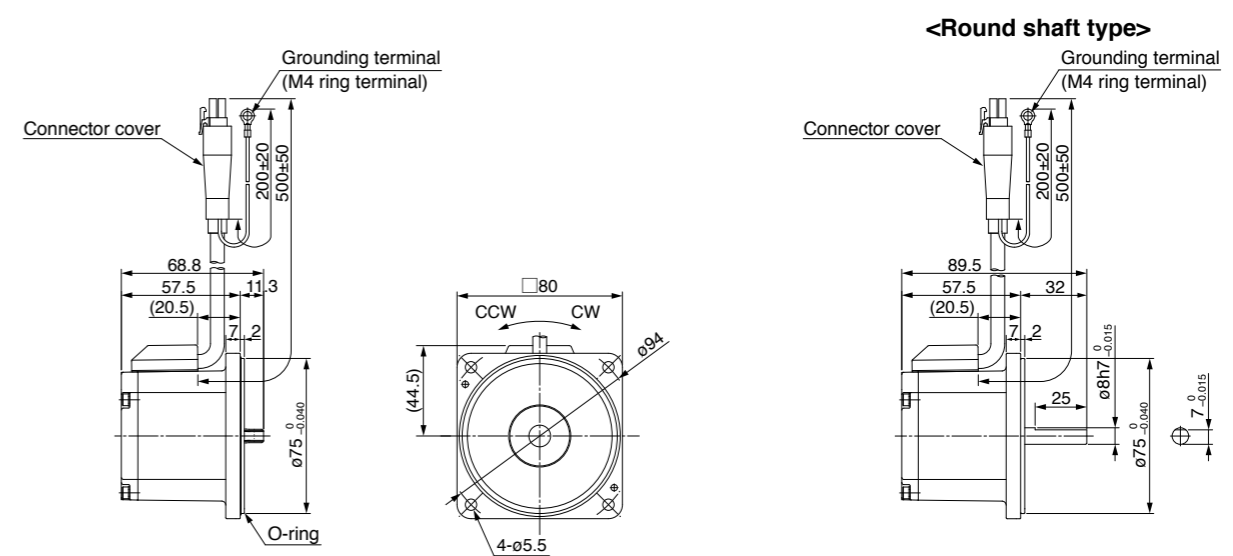

mass **0.7 kg**

Gear head (dimensions)

Unit mm

MX8G□B

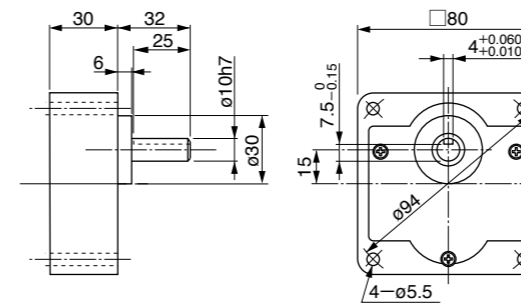

mass **0.6 kg**

<Key and keyway [attachment]>

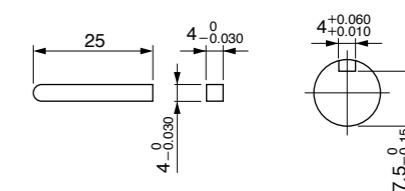

Brushless amplifier (dimensions)

Unit mm

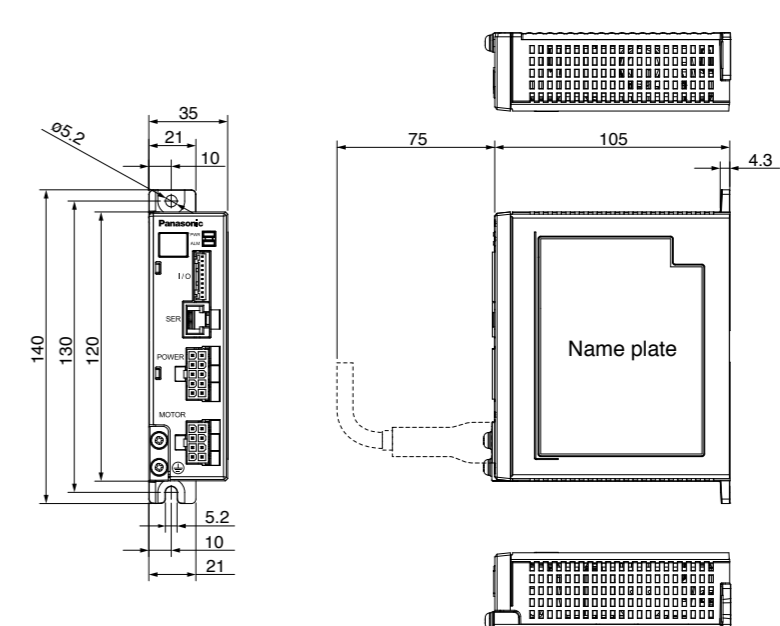

mass **0.37 kg**

<Cautions> Dimensions are subject to change without notice. Contact us or a dealer for the latest information.

Specification (For Common specification, see p. 11, p. 12)

Size	Model No. / Amplifier and Motor		Rated output (W)	Input power supply for Amplifier			Rated torque (N·m)	Starting torque (N·m)	Rated speed (r/min)	Maximum rotation speed (r/min)	
	Brushless Amplifier Model number in () is shipped with power connection cable	Motor		Voltage AC (V)	Allowed range (%)	Frequency (Hz)					Rated input current (A)
90 mm sq.	MBEG1E1BCV (MBEG1E1BCVC)	MBMU1E1A○	130	Single phase 100 to 120	±10	50/60	2.8	0.41	0.62	3000	4000
	MBEG1E5BCV (MBEG1E5BCVC)	MBMU1E2A○		Single phase 1.5 3-phase 0.7							

* Suffix of "○" in the motor model No. represents shape of shaft. Refer to the "Check the model number" p. 11. * Starting torque: Representative value

Permissible torque at output shaft of gear head (N·m)

Applicable Gear head	Reduction ratio	Reduction ratio																													
		3	3.6	5	6	7.5	9	10	12.5	15	18	20	25	30	36	50	60	75	90	100	120	150	180	200							
MZ9G□B MY9G□B	motor rotation speed (r/min)	3000 or less	1.01	1.21	1.69	2.02	2.54	3.04	3.42	3.82	4.59	5.58	6.17	7.91	9.34	10.5	14.7	17.5	19.6												
	3000 to 4000	100 V	0.59	0.71	0.99	1.18	1.49	1.78	2.00	2.24	2.69	3.27	3.61	4.63	5.47	6.15	8.60	10.2	12.9	15.4	17.2	19.6									
		200 V	0.76	0.91	1.27	1.52	1.91	2.28	2.57	2.87	3.44	4.19	4.63	5.93	7.01	7.88	11.0	13.1	16.5	19.6											
Rotational direction		Same as motor rotational direction										Reverse to motor rotational direction					Same as motor rotational direction														

Permissible load inertia moment (×10⁻⁴ kg·m²)

Reduction ratio	Reduction ratio																							
Applicable Gear head	3	3.6	5	6	7.5	9	10	12.5	15	18	20	25	30	36	50	60	75	90	100	120	150	180	200	
MZ9G□B / MY9G□B	5.93	8.47	16.4	23.6	37.3	53.4	67.6	98.3	142	211	257	423	589	847	1684									

Permissible shaft load

Motor shaft (Round shaft)	Output	Overhung load (W)	Thrust load (F)
Applicable Gear head	130 W	150 N	20 N
	MZ9G□B / MY9G□B	588 N	147 N

Wiring diagram

In Case of 3-Phase 200 V
*When you use single phase, connect the main power between L1 and L2 terminals.

External speed setter Option: DV0PM20078 Variable resistor 5 kΩ B characteristic 1/4 W

Please refer to P.69 for the wiring of the motor extension cable.

Be sure to ground the grounding terminal.

In wiring to power supply (outside of equipment) from MCCB, use an electric wire of 1.6 mm diameter (2.0 mm²) or more both for main circuit and grounding. Apply grounding class D (100 Ω or below) for grounding. Do not tighten the ground wires together, but connect them individually.

* Please refer to P.95 Support option.

* Before using, be sure to read "Instruction manual" to check precautions and correct procedure.

Motor (dimensions)

Unit mm

mass **1.2 kg**

Gear head (dimensions)

Unit mm

MZ9G□B (Ball bearing/Hinge not attached) mass **1.4 kg**

MY9G□B (Ball bearing/Hinge attached) mass **1.4 kg**

Brushless amplifier (dimensions)

Unit mm

mass **0.37 kg**

<Key and keyway [attachment]>

<Cautions> Dimensions are subject to change without notice. Contact us or a dealer for the latest information.

Outline of gear head

Reduction ratio

• 22 reduction ratios from 1/3 to 1/180 are available for the X type; 23 reduction ratios from 1/3 to 1/200 are available for the Y and Z types.

Gear type

X: 50 W
Z: 90 W, 130 W (Hinge not attached)
Y: 90 W, 130 W (Hinge attached)

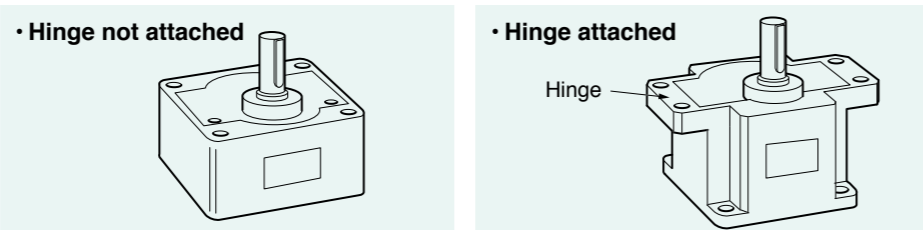

Backlash

Less than 2° (design value)

■ Type of gear head and reduction ratio

Gear type	Motor capacity	Reduction ratio																							
		1/3	1/3.6	1/5	1/6	1/7.5	1/9	1/10	1/12.5	1/15	1/18	1/20	1/25	1/30	1/36	1/50	1/60	1/75	1/90	1/100	1/120	1/150	1/180	1/200	
X	50 W	○	○	○	○	○	○	○	○	○	○	○	○	○	○	○	○	○	○	○	○	○	○	○	—
Z, Y	90 W, 130 W	○	○	○	○	○	○	○	○	○	○	○	○	○	○	○	○	○	○	○	○	○	○	○	○

Check the Model number

M **Z** **9** **G** **30** **B**

- Output Type**
X : 50 W
Z, Y : 90 W, 130 W
- Size**
8 : 80 mm sq.
9 : 90 mm sq.
- Reduction ratio**
(Example) 30: Reduction ratio of 1/30
- Bearing**
B: Ball bearing

* The motor and gear are sold separately.

Calculation of torque at output shaft of gear head

■ Standard gear head only

$$N_G = \frac{N_M}{i}$$

N_G : Speed of gear head (r/min) T_G : Output torque of gear head (N·m)

$$T_G = T_M \times i \times \eta$$

N_M : Motor speed (r/min) T_M : Motor torque (N·m)

i : Reduction ratio of gear head η : Gear head efficiency

Maximum permissible torque

There is a limit to the strength of a gear due to its material and construction. The usable load torque determined based on this limit is called permissible torque. As can be seen from the above-mentioned formula, the load becomes larger when the reduction ratio is increased. If the gear head is used with the load exceeding the permissible torque, its life expectancy will be shortened significantly. Refer to the right graph and the permissible torque for each model and use the gear head at an appropriate load.

■ Maximum permissible torque

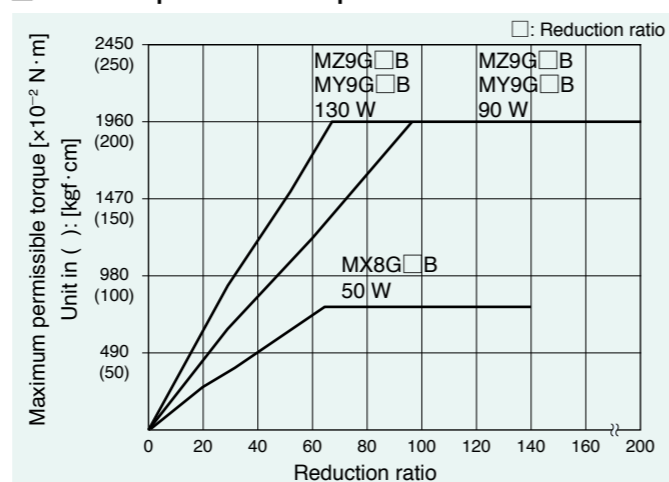

Nominal reduction ratio and actual reduction ratio

Note that there is a difference between the nominal reduction ratio and actual reduction ratio of each gear head. The numbers in the following table represents the denominator of the actual reduction ratio.

Gear type	Nominal reduction ratio																							
	1/3	1/3.6	1/5	1/6	1/7.5	1/9	1/10	1/12.5	1/15	1/18	1/20	1/25	1/30	1/36	1/50	1/60	1/75	1/90	1/100	1/120	1/150	1/180	1/200	
Actual reduction ratio	MX8G□B	3.01	3.60	4.98	5.96	7.48	9.00	9.99	12.5	14.9	18.1	20.1	25.1	30.3	36.4	49.8	61.2	76.2	90.5	98.0	122.5	148.9	183.5	—
	MZ9G□B	3.02	3.61	5.03	6.02	7.58	9.06	10.2	12.3	14.8	18.0	19.9	25.5	30.1	36.1	50.9	60.5	76.0	89.8	98.6	121.2	150.4	182.1	202.1
	MY9G□B																							

Gear head efficiency

Gear type	Nominal reduction ratio																					
	1/3	1/3.6	1/5	1/6	1/7.5	1/9	1/10	1/12.5	1/15	1/18	1/20	1/25	1/30	1/36	1/50	1/60	1/75	1/90	1/100	1/120	1/150	1/180
MX8G□B	81 %										75 %										—	
MZ9G□B	81 %					79 %					70 %											
MY9G□B																						

Gear head efficiency and ambient temperature

Calculate the actual gear head efficiency by multiplying the above-shown gear head efficiency at room temperature by the torque reduction ratio shown right.

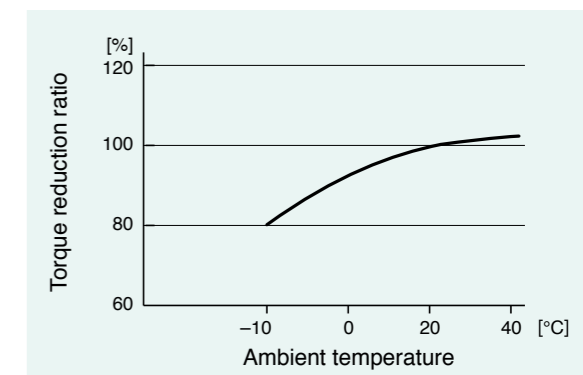

Standard life

Standard life is 5000 hours for the motor equipped with gear head. Standard life of the motor without gear head (round shaft) is 10000 hours (however, effective life of the oil seal is 5000 hours). Standard life is the designed lifetime predicted based on assumption that it is operated 8 hours/day (service factor: Sf = 1.0) under uniform loading (gear head allowable shaft torque, motor rated torque) at normal temperature and humidity.

Typical motor life can be determined as follows:
Example: Motor speed 3000 r/min to 4000 r/min
Standard life (hours) = 5000 (hours) × 3000 (r/min) / operating speed (r/min)

Service factor (Sf)

$$\text{Life expectancy} = \frac{\text{Standard life}}{\text{Service factor (Sf)}}$$

Service factor (Sf) varies with impact of load and operation time. The table below shows how the service factor value depends on load condition.

Type of load	Typical load	Service factor		
		5 hours/day	8 hours/day	24 hours/day
Constant	Belt conveyor, One-directional rotation	1.0	1.0	1.5
Light-impact	Start/Stop, Cam-drive	1.2	1.5	2.0
Medium-impact	Instant FWD/REV, Instant stop	1.5	2.0	2.5
Heavy-impact	Frequent medium-impact	2.5	3.0	3.5

<Important>

The gear heads MB8G□BV and MB9G□BV are designed for use with GP series, and MX8G□B, MZ9G□B and MY9G□B are designed for use with GV series, respectively, and they are not compatible with gear heads of different series.

Gear head GV series

Model list of gear head

Gear head

Ball bearing

Size	Reduction ratio	Model No.	Hinge
80 mm sq. (50 W)	1/3, 1/3.6, 1/5, 1/6, 1/7.5, 1/9, 1/10, 1/12.5, 1/15, 1/18	MX8G3B to MX8G18B	
	1/20, 1/25, 1/30, 1/36	MX8G20B to MX8G36B	
	1/50, 1/60, 1/75, 1/90, 1/100, 1/120, 1/150, 1/180	MX8G50B to MX8G180B	
90 mm sq. (90 W - 130 W) (Common use)	1/3, 1/3.6, 1/5, 1/6, 1/7.5, 1/9	MZ9G3B to MZ9G9B	
	1/10, 1/12.5, 1/15, 1/18	MZ9G10B to MZ9G18B	
	1/20, 1/25, 1/30, 1/36, 1/50, 1/60	MZ9G20B to MZ9G60B	
	1/75, 1/90, 1/100, 1/120, 1/150, 1/180, 1/200	MZ9G75B to MZ9G200B	
	1/3, 1/3.6, 1/5, 1/6, 1/7.5, 1/9	MY9G3B to MY9G9B	○
	1/10, 1/12.5, 1/15, 1/18	MY9G10B to MY9G18B	○
	1/20, 1/25, 1/30, 1/36, 1/50, 1/60	MY9G20B to MY9G60B	○
1/75, 1/90, 1/100, 1/120, 1/150, 1/180, 1/200	MY9G75B to MY9G200B	○	

* For the specifications for each item, refer to the page of the motor to which it can be applied.

Gear head accessory

Ball bearing

Size	Reduction ratio	Model No.	Accessory			
			Screw (mm)	Flat washer	Hexagon nut	Key
80 mm sq.	1/3 to 1/180	MX8G3B to MX8G180B	M5 × 55 pan head screw : 4	for M5: 4	M5 : 4	4×4×25 one-end round : 1
90 mm sq.	1/3 to 1/200	MZ9G3B to MZ9G200B	M6 × 85 hexagon socket head bolt : 4	for M6: 4	M6 : 4	5×5×25 one-end round : 1
	1/3 to 1/200	MY9G3B to MY9G200B	M6 × 25 hexagon socket head bolt : 4	for M6: 4	M6 : 4	5×5×25 one-end round : 1

O-ring

Repair parts 10pcs / bag

Size	Part No.
80 mm sq.	DV0PN10008
90 mm sq.	DV0PN10009

- Assemble with motor pinion faced up.
- Outward direction of motor leadwire can be aligned with any one of 4 sides of gear head with an output shaft at a different position.

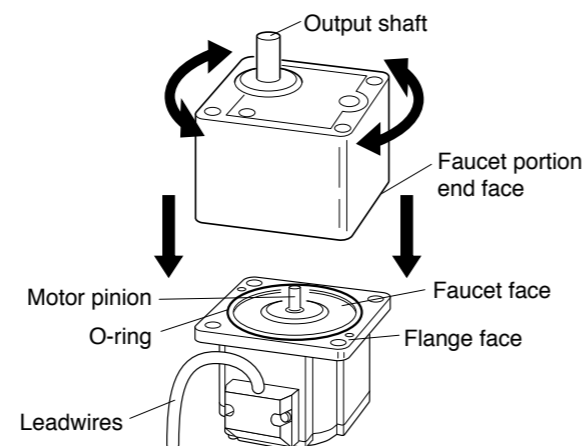

MINAS-BL KV series

Speed Control Type 50 W to 750 W

KV series



• 60 mm square 200 W

Contents	
Check the model number	27
Brushless motor specifications	27
Brushless amplifier specifications	28
System configuration/ System configuration diagram	29
Parameter list of brushless amplifier	33
Brushless motors – Details	35

Check the model number

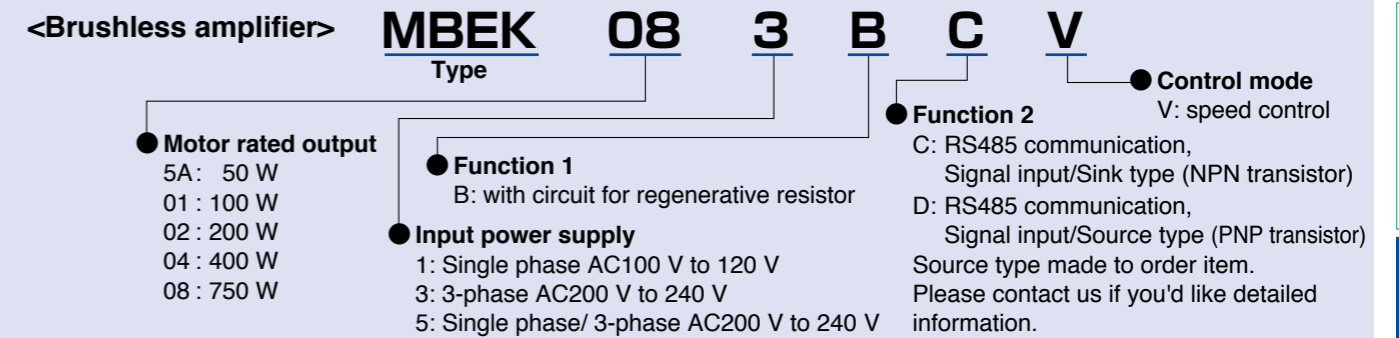
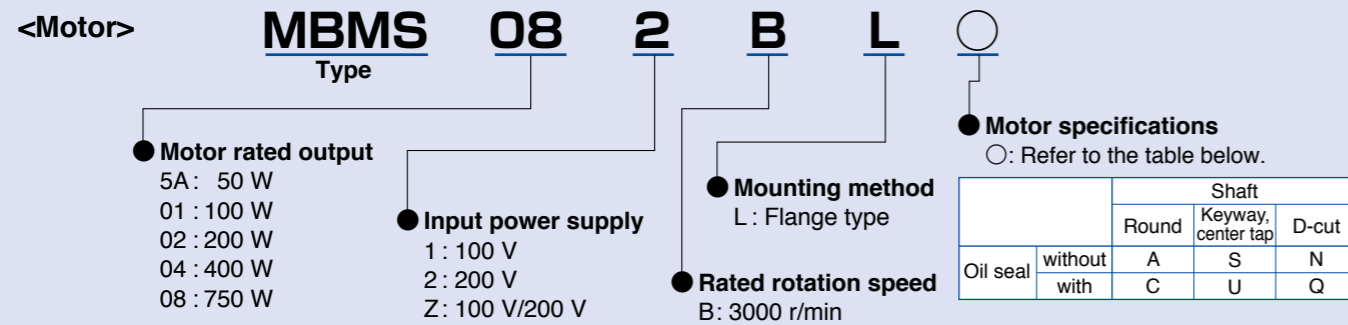

Brushless motor specifications

Item	Specifications						
	38 mm sq.	60 mm sq.				80 mm sq.	
Motor model No. ^{*1}	MBMS5AZBL○	MBMS011BL○	MBMS012BL○	MBMS021BL○	MBMS022BL○	MBMS042BL○	MBMS082BL○
Motor rated output (W)	50	100		200		400	750
Voltage (V)	for 100/200	for 100	for 200	for 100	for 200	for 200	
Rated torque (N·m)	0.16	0.32		0.64		1.27	2.4
Starting torque ^{*2} (N·m)	0.30	0.70		1.4		3.0	5.2
Rated input current (A(rms))	0.74	1.4	0.76	2.9	1.8	2.8	3.6
Moment of inertia of rotor (×10 ⁻⁴ kg·m ²)	0.025	0.07		0.14		0.26	0.87
Rating	Continuous						
Rated rotation speed ^{*3} (r/min)	3000						
Speed control range (r/min)	100 to 4000						
Ambient temperature	0 °C to +40 °C (free from freezing) * Ambient temperature is measured at a distance of 5 cm from the motor.						
Ambient humidity	20 % to 85 % RH (free from condensation)						
Altitude	Lower than 1000 m						
Vibration	24.5 m/s ² or less X,Y,Z (Center of frame)						
Motor insulation class	130(B)						
Protection structure	IP65 ^{*4,5}						
Number of poles	8						
Motor mass (kg)	0.32	0.63		0.80		1.2	2.3

*1 Suffix of "○" in the motor model represents shape of shaft.

*2 Representative value

*3 Motor shaft speed: to be multiplied by the reduction ratio when the gear head is used.

*4 Excluding the shaft pass-through section and cable end connector.

*5 These motors conform to the test conditions specified in EN standards (EN60529, EN60034-5).
Do not use these motors in application where water proof performance is required such as continuous wash-down operation.

Overload protection characteristics

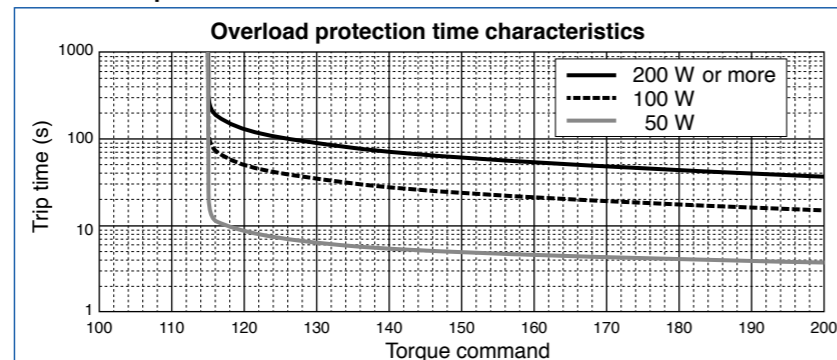

• 100 of the torque command represents the rated torque.

Brushless amplifier specifications (KV series)

Item	Specifications																						
	MBEK5A1BCV			MBEK5A5BCV			MBEK011BCV			MBEK015BCV			MBEK021BCV			MBEK025BCV			MBEK045BCV			MBEK083BCV	
Amplifier model No.																							
Applicable Motor ^{*1}	MBMS5AZBL○			MBMS011BL○			MBMS012BL○			MBMS021BL○			MBMS022BL○			MBMS042BL○			MBMS082BL○				
Motor rated output (W)	50			100			200			400			750										
Input power supply voltage (V)	Single phase 100 to 120	Single phase 200 to 240	3-phase	Single phase 100 to 120	Single phase 200 to 240	3-phase	Single phase 100 to 120	Single phase 200 to 240	3-phase	Single phase 100 to 120	Single phase 200 to 240	3-phase	Single phase 100 to 120	Single phase 200 to 240	3-phase	Single phase 100 to 120	Single phase 200 to 240	3-phase	Single phase 100 to 120	Single phase 200 to 240	3-phase		
Frequency (Hz)	50/60																						
Rated input current (A)	1.8	0.9	0.5	2.4	1.3	0.7	4.2	2.1	1.2	3.8	2.1	4.0											
Voltage tolerance	±10 %																						
Control method	Speed control by CS signal, PWM sine wave driving system																						
Ambient temperature	0 °C to +50 °C (free from freezing) * Ambient temperature is measured at a distance of 5 cm from the amplifier.																						
Ambient humidity	20 % to 85 % RH (free from condensation)																						
Location	Indoor (No corrosive gas, A place without garbage, and dust)																						
Altitude	Lower than 1000 m																						
Vibration	5.9 m/s ² or less (10 Hz to 60 Hz)																						
Protection structure/ Cooling system	Equivalent to IP20/ Self cooling																						
Storage temperature	Normal temperature * Temperature which is acceptable for a short time, such as during transportation is -20 °C to 60 °C (free from freezing)																						
Storage humidity	Normal humidity																						
Rated rotation speed	3000 r/min																						
Speed control range	100 r/min to 4000 r/min																						
Speed fluctuation factor	With load	±0.5 % or below (at 0 to Rated torque, Rated rotation speed)																					
	With voltage	±0.5 % or below (at supply voltage ±10 %, rated rotation speed)																					
	With temperature	±0.5 % or below (at 0 °C to 50 °C, rated rotation speed)																					
Acceleration/ Deceleration time	0.01 sec to 300 sec (time for changing 1000 r/min) ^{*2}																						
Stopping procedure	Slowdown stop/ Free-run stop ^{*2}																						
Speed setting	0 r/min to 4000 r/min (analogue voltage (0 V to 5 V), console A), 0 r/min to 4000 r/min (Setting selection by parameter on Digital key pad)																						
Speed setting resolution	Analog: approx. 1/200 of upper speed limit Digital: 1 r/min																						
Speed setting precision (at 20 °C)	Analog: ±3 % or below of upper speed limit (±90 r/min or below at upper speed limit 3000 r/min) [Digital: 1 % or below of upper speed limit]																						
Operation mode	8 speed																						
Signal input	5 inputs ^{*2} (run/ stop, CW run/ CCW run, multi function 3 bit)																						
Signal output	2 outputs (Open collector) ^{*2} (Trip output etc)																						
Communication function	RS485	Max 31 units. Setting of parameter, monitoring of control condition. Communication speed: Choose from 2400 bps/ 4800 bps/ 9600 bps																					
	RS232	Setting of parameter and monitoring of control condition are enabled with commercial PC. ^{*3}																					
Digital key pad	Setting of parameter, monitoring of control condition. ^{*4}																						
Protective function	Warning : Undervoltage ^{*2} , Overload warning, setting change warning Protect : Undervoltage ^{*2} , Overload, Overcurrent, Overvoltage, Overheat, Overspeed, Sensor error, RS485 communication error, External forced trip error, User parameter error, CPU error																						
Regenerating brake	Regenerative braking resistor can be externally connected. ^{*5} Instantaneous braking torque 200 %, Continuous regenerative ability of external regenerative resistor: 10 W (Regenerative operation with which motor shaft is rotated by load, e.g. load lowering operation, should not be continued.)																						
Protection level	Protection level: torque command 115 (inverse time characteristics)																						
Amplifier mass (kg)	0.37 (50 W, 100 W) / 1.0 (200 W to 750 W)																						

*1 Suffix of "○" in the motor model represents shape of shaft. *2 Can be changed from PANATERM for BL or Digital key pad.

*3 PANATERM for BL (Download from our web site.), PC connection cable (DV0P4140), Digital key pad connection cable (DV0P383*0) is required. If your PC does not have RS232 port, use RS232-USB converter.

*4 Digital key pad connection cable (DV0P383*0) is required. *5 Use optional external regenerative resistor (sold separately).

System configuration (50 W, 100 W)

Power supply	Rated rotation speed (r/min)	output (W)	Motor (Note 1)	Brushless amplifier	Brushless amplifier (supplied with power cable) (Note 2)	Optional parts			
						External regenerative resistor	Noise filter	Surge absorber	Reactor
Single phase 100 V	3000	50	MBMS5AZBL○	MBEK5A1BCV	MBEK5A1BCVC	for 100 V DV0P2890	for single phase power supply DV0P4170	for single phase power supply DV0P4190	for single phase power supply DV0P227
		100	MBMS011BL○	MBEK011BCV	MBEK011BCVC				
Single/3-phase 200 V	3000	50	MBMS5AZBL○	MBEK5A5BCV	MBEK5A5BCVC	for 200 V DV0PM20068	for single phase power supply DV0P4170 for 3-phase power supply DV0PM20042	for single phase power supply DV0P4190 for 3-phase power supply DV0P1450	for single phase power supply DV0P227 for 3-phase power supply DV0P220
		100	MBMS012BL○	MBEK015BCV	MBEK015BCVC				

(Note 1) ○ : Refer to the table below.

		Shaft shape		
		Round	Keyway, center tap	D-cut
Oil seal	Without	A	S	N
	With	C	U	Q

(Note 2) Refer to p. 74 for a power supply connecting cable.

This part number is the ordering part number for the amplifier and power cable, not for ordering amplifier only. The supplied power connecting cable is for single-phase input, when supplying three-phase power; please make a cable using optional power connection kit (DV0P2870).

* When installing the reactor, refer to p. 73.

- * Be sure to use a set of matched components (power source, capacity, output, etc.)
- * This motor is not provided with a holding brake. If it is used to drive a vertical shaft, the movable section may fall down by its own weight as power is turned off.

Options

Optional parts	Parts number	Reference page	Optional parts	Parts number	Reference page	
Motor extension cable	1 m	DV0PQ1000310	Digital key pad connection cable	1 m	DV0P38310	
	3 m	DV0PQ1000330		3 m	DV0P38330	
	5 m	DV0PQ1000350		5 m	DV0P38350	
	10 m	DV0PQ10003A1				
Power supply connector kit	DV0P2870	P.70	External speed setter	DV0PM20078	P.71	
Console A ¹	DV0P3500	P.68	Control signal cable	2 m	DV0PM20076	P.70
Console A connection cable	1 m	DV0PM2006910	I/O connector kit	DV0PM20070	P.71	
	3 m	DV0PM2006930	Panel connector kit	DV0P3610	P.71	
	5 m	DV0PM2006950	PC connection cable ³	1.5 m	DV0P4140	P.70
Digital key pad ²	DV0P3510	P.68	Noise filter for signal line	DV0P1460	P.67	
			DIN rail mounting unit	DV0P3811	P.72	

* For details of cable, refer to p. 68 to p. 70.

*1 When using Console A, the Console A connection cable (DV0PM20069*0) is required.

*2 When using Digital key pad, the Digital key pad connection cable (DV0P383*0) is required.

*3 When connecting PC, the PC connection cable (DV0P4140) and the Digital key pad connection cable (DV0P383*0) are required.

Wiring equipment

Selection of circuit breaker (MCCB), magnetic contactor and electric wire. (To check conformity with international standards, refer to p. 93 Conformity with international safety standards.)

Voltage	Power capacity	MCCB Rated current	Magnetic contactor Rated Current (Contact composition)	Core of electric wire (mm ²)	
				Main circuit, Grounding	Control circuit
Single phase 100 V	50 W, 100 W	5 A	20 A (3P+1a)	0.5 (AWG20)	0.13 (AWG26)
Single phase 200 V					
3-phase 200 V					

Be sure to connect the earth terminal to ground.

In wiring to power supply (outside of equipment) from MCCB, use an electric wire of 1.6 mm diameter (2.0 mm²) or more both for main circuit and grounding. Apply grounding class D (100 Ω or below) for grounding.

Selection of relay

A relay used in a control circuit, e.g. at the control input terminal should be small signal relay (Min. guaranteed current 1 mA or less) for positive contact. <Example> Panasonic: DS type, HC type OMRON: G2A type

Selection of control circuit switch

When using a switch in place of relay, select a switch rated at minute electric current, to assure positive contact.

<Example> Nihon Kaiheiki Ind.: M-2012J-G

The wiring of SER and I/O connector

The wiring of SER and I/O connector should separate from power line to prevent malfunction.

Wiring to the I/O connector

Permissible length for control signal cable is 5 m or less.

System configuration diagram (50 W, 100 W)

Example of analog setting (Console A)

- Set the speed with the speed setting knob (variable resistor).
- Start/stop the motor from the RUN/STOP switch.
- To change rotating direction, use the rotation direction selector switch.

When not using Console A

Motor controls such as start/stop, direction change and speed setting can be done from external potentiometer and switch through optional control signal cable or I/O connector kit.

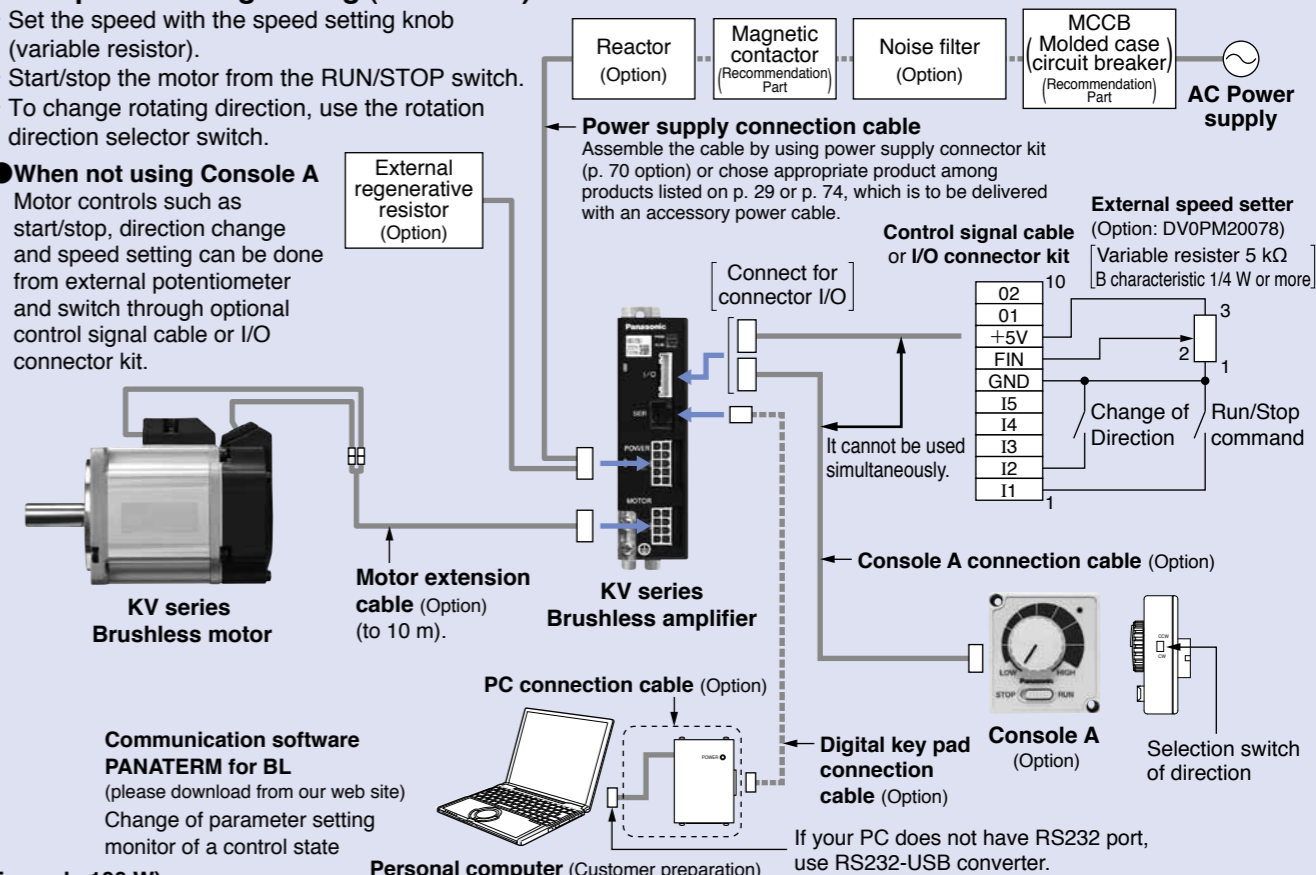

(Example 100 W)

Example of digital setting (Digital key pad)

- To start/stop the motor, use RUN/STOP key
- Digital monitor [Rotation speed, Commanded speed, Internal DC voltage, Load factor, Torque, Trip history, Overload warning (flashing)]
- Set/change parameters
- Storage of the parameters (read, write)

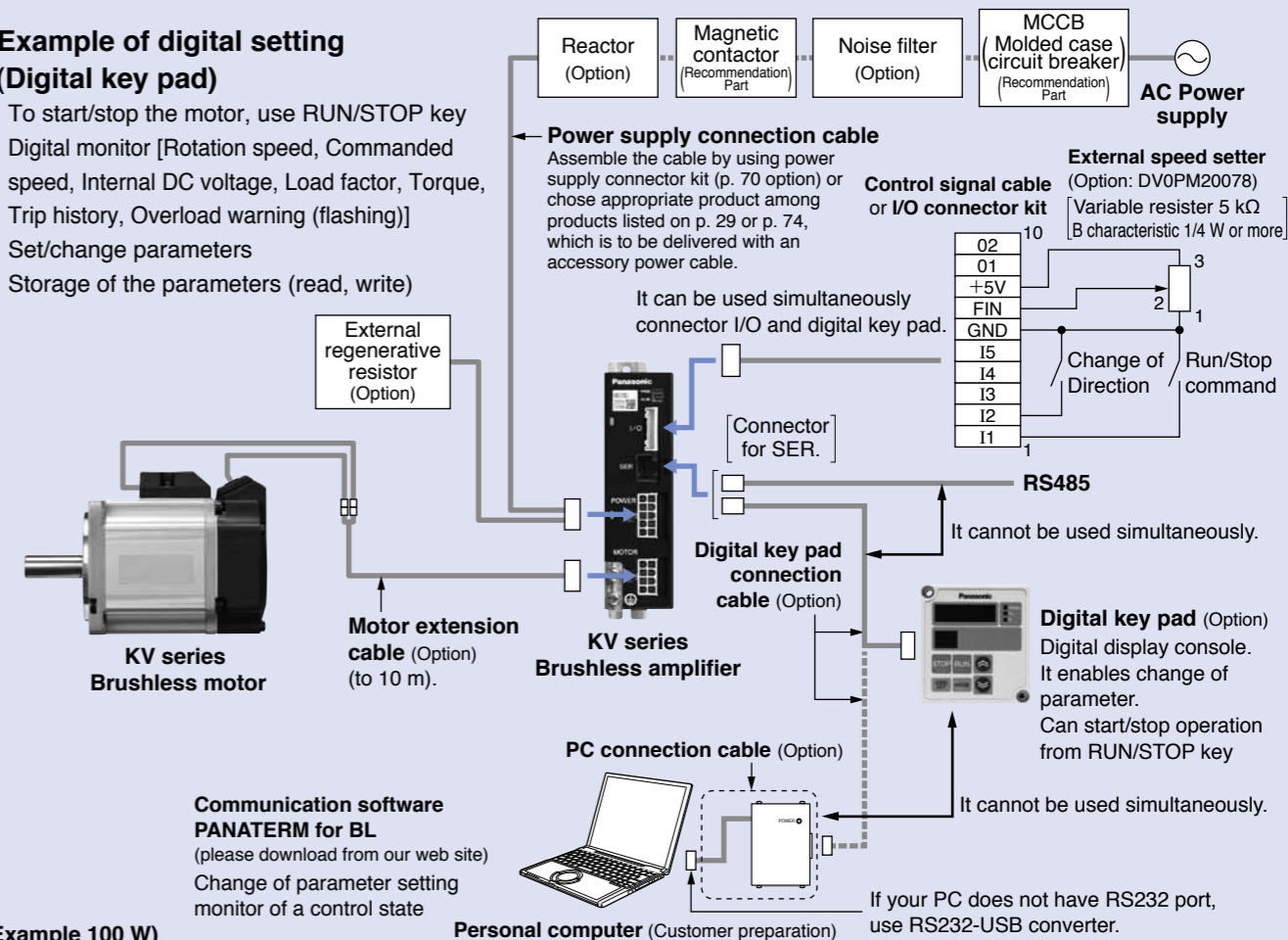

(Example 100 W)

System configuration (200 W to 750 W)

Power supply	Rated rotation speed (r/min)	output (W)	Motor (Note 1)	Brushless amplifier	Optional parts			
					External regenerative resistor	Noise filter	Surge absorber	Reactor
Single phase 100 V	3000	200	MBMS021BL○	MBEK021BCV	for 100 V DV0P2890	for single phase power supply DV0P4170	for single phase power supply DV0P4190	for single phase power supply DV0P228
Single/3-phase 200 V		200	MBMS022BL○	MBEK025BCV	for 200 V DV0PM20068	for single phase power supply DV0P4170	for single phase power supply DV0P4190	for single phase power supply DV0P227
		400	MBMS042BL○	MBEK045BCV		for 3-phase power supply DV0PM20042	for 3-phase power supply DV0P1450	for 3-phase power supply DV0P220
3-phase 200 V	750	MBMS082BL○	MBEK083BCV	for 3-phase power supply DV0PM20042	for 3-phase power supply DV0P1450	for 3-phase power supply DV0P220		

(Note 1) ○ : Refer to the table below.

		Shaft shape		
		Round	Keyway, center tap	D-cut
Oil seal	Without	A	S	N
	With	C	U	Q

* When installing the reactor, refer to p. 73.

*** Be sure to use a set of matched components (power source, capacity, output, etc.)**
*** This motor is not provided with a holding brake. If it is used to drive a vertical shaft, the movable section may fall down by its own weight as power is turned off.**

Options

Optional parts	Parts number	Reference page	Optional parts	Parts number	Reference page	
Motor extension cable	1 m	DV0PQ1000310	Digital key pad connection cable	1 m	DV0P38310	
	3 m	DV0PQ1000330		3 m	DV0P38330	
	5 m	DV0PQ1000350		5 m	DV0P38350	
	10 m	DV0PQ10003A1	External speed setter	DV0PM20078	P.71	
Console A ¹	DV0P3500	P.68	Control signal cable	2 m	DV0PM20076	P.70
Console A connection cable	1 m	DV0PM2006910	I/O connector kit	DV0PM20070	P.71	
	3 m	DV0PM2006930	Panel connector kit	DV0P3610	P.71	
	5 m	DV0PM2006950	PC connection cable ³	1.5 m	DV0P4140	P.70
Digital key pad ²	DV0P3510	P.68	Noise filter for signal line	DV0P1460	P.67	

* For details of cable, refer to p. 68 to p. 70.

*1 When using Console A, the Console A connection cable (DV0PM20069*0) is required.

*2 When using Digital key pad, the Digital key pad connection cable (DV0P383*0) is required.

*3 When connecting PC, the PC connection cable (DV0P4140) and the Digital key pad connection cable (DV0P383*0) are required.

Wiring equipment

Selection of circuit breaker (MCCB), magnetic contactor and electric wire. (To check conformity with international standards, refer to p. 93 Conformity with international safety standards.)

Voltage	Power capacity	MCCB Rated current	Magnetic contactor Rated Current (Contact composition)	Core of electric wire (mm ²)	
				Main circuit, Grounding	Control circuit
Single phase 100 V	200 W	10 A	20 A (3P+1a)	0.75 (AWG18)	0.13 (AWG26)
Single phase 200 V	200 W	5 A			
	400 W	10 A			
3-phase 200 V	400 W, 200 W	5 A			
	750 W	10 A			

Be sure to connect the earth terminal to ground.

In wiring to power supply (outside of equipment) from MCCB, use an electric wire of 1.6 mm diameter (2.0 mm²) or more both for main circuit and grounding. Apply grounding class D (100 Ω or below) for grounding.

Selection of relay

A relay used in a control circuit, e.g. at the control input terminal should be small signal relay (Min. guaranteed current 1 mA or less) for positive contact. <Example> Panasonic: DS type, HC type OMRON: G2A type

Selection of control circuit switch

When using a switch in place of relay, select a switch rated at minute electric current, to assure positive contact.

<Example> Nihon Kaiheiki Ind.: M-2012J-G

The wiring of SER and I/O connector

The wiring of SER and I/O connector should separate from power line to prevent malfunction.

Wiring to the I/O connector

Permissible length for control signal cable is 5 m or less.

System configuration diagram (200 W to 750 W)

Example of analog setting (Console A)

- Set the speed with the speed setting knob (variable resistor).
- Start/stop the motor from the RUN/STOP switch.
- To change rotating direction, use the rotation direction selector switch.

When not using Console A

Motor controls such as start/stop, direction change and speed setting can be done from external potentiometer and switch through optional control signal cable or I/O connector kit.

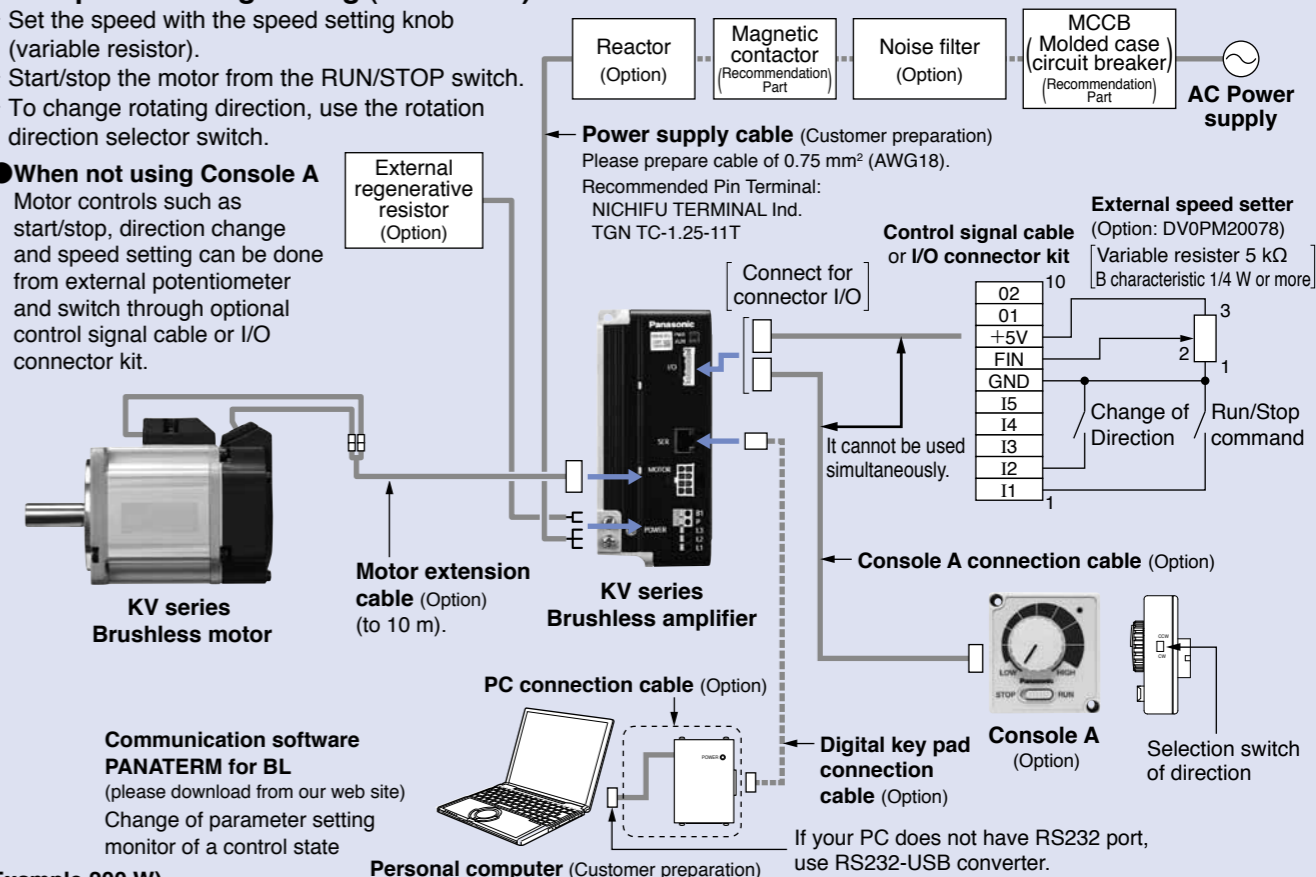

(Example 200 W)

Example of digital setting (Digital key pad)

- To start/stop the motor, use RUN/STOP key
- Digital monitor [Rotation speed, Commanded speed, Internal DC voltage, Load factor, Torque, Trip history, Overload warning (flashing)]
- Set/change parameters
- Storage of the parameters (read, write)

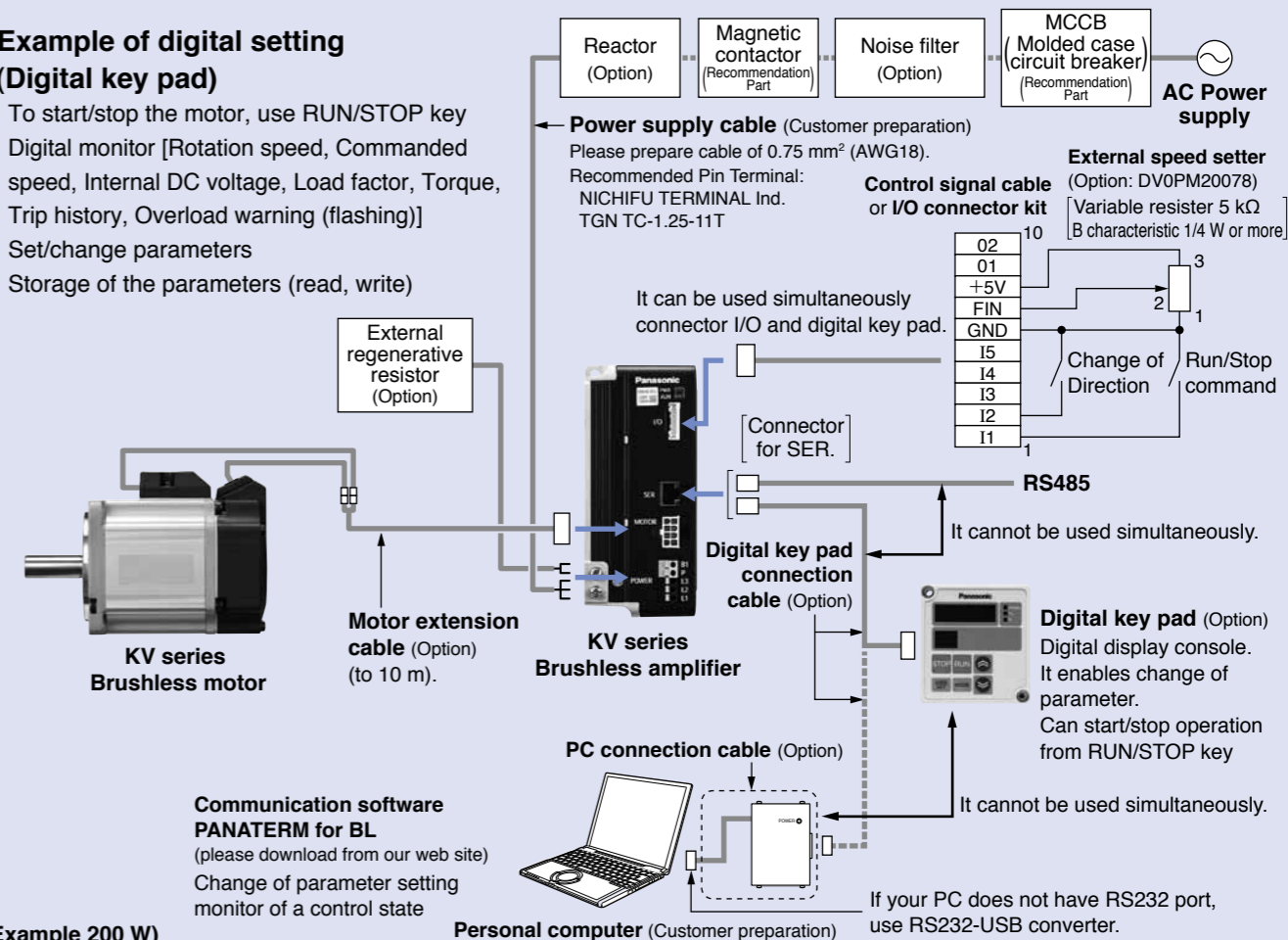

(Example 200 W)

Parameter list of brushless amplifier

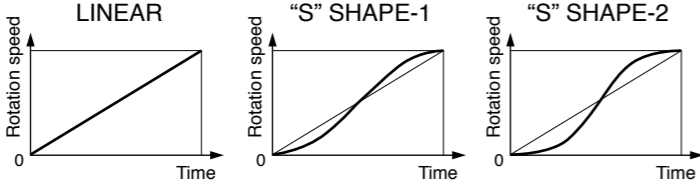
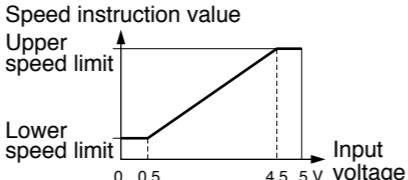
Parameter No.	Parameter name	Explanation	Setting range																												
00	Internal speed (0-th speed)	Desired running speed can be set with the Digital key pad.	0 r/min to Upper speed limit [Minimum unit 1 r/min]																												
01 to 07	1st speed to 7th speed	Speed in multi-speed running can be set.	0 r/min to Upper speed limit [Minimum unit 1 r/min]																												
10	1st acceleration time	The change factor of output speed in acceleration can be determined. Set by time for changing 1000 r/min.	0.01 sec to 300 sec																												
11	2nd acceleration time		to 3 sec: Incremented by 0.01 second 3 sec to 30 sec: Incremented by 0.1 second 30 sec to 300 sec: Incremented by 1 second																												
12	1st deceleration time	The change factor of output speed in deceleration can be determined. Set by time for changing 1000 r/min.	0.01 sec to 300 sec																												
13	2nd deceleration time		to 3 sec: Incremented by 0.01 second 3 sec to 30 sec: Incremented by 0.1 second 30 sec to 300 sec: Incremented by 1 second																												
14	Acceleration mode selection	Straight line acceleration/deceleration and curve (S-shape) acceleration and deceleration can be chosen individually for acceleration and deceleration. 	Select S-shape when "31 Speed command selection" is PnL.																												
15	Deceleration mode selection																														
16	Stop mode selection	You can select how to stop the motor when stop command is input: free-run stop or stop after deceleration.																													
17	Free-run waiting time	When the stop mode is set to deceleration stop, the zero speed (servo lock time) after deceleration can be adjusted.	0.0 sec to 10.0 sec [Minimum unit 0.1 sec]																												
1A	Velocity loop proportional gain	Enables setting of proportional gain of velocity amplifier.	0 to 10000 [Minimum unit 0.1]																												
1b	Velocity loop integration gain	Enables setting of integration gain of velocity amplifier.	0 to 10000 [Minimum unit 0.1]																												
30	Run command selection	Run command can be applied through: Digital key pad, input terminal "I1", "I2" or RS485 communication, whichever selected.																													
31	Speed command selection	You can choose whether to use "00 Internal speed (0-th speed)" or analog input terminal for speed command.																													
32	Operation mode selection	Parameter for choosing operation mode <table border="1" data-bbox="415 1249 1062 1543"> <thead> <tr> <th rowspan="2">Setting</th> <th rowspan="2">Operation mode</th> <th colspan="3">Function of signal input</th> </tr> <tr> <th>I3</th> <th>I4</th> <th>I5</th> </tr> </thead> <tbody> <tr> <td>1</td> <td>1st speed operation mode</td> <td></td> <td></td> <td>Free-run stop External forced trip</td> </tr> <tr> <td>2</td> <td>2nd speed operation mode</td> <td>Speed setting</td> <td></td> <td>2nd Acc./Dec. time Trip reset</td> </tr> <tr> <td>4</td> <td>4th speed operation mode</td> <td>Speed setting</td> <td>Speed setting</td> <td></td> </tr> <tr> <td>8</td> <td>8th speed operation mode</td> <td>Speed setting</td> <td>Speed setting</td> <td>Speed setting</td> </tr> </tbody> </table>	Setting	Operation mode	Function of signal input			I3	I4	I5	1	1st speed operation mode			Free-run stop External forced trip	2	2nd speed operation mode	Speed setting		2nd Acc./Dec. time Trip reset	4	4th speed operation mode	Speed setting	Speed setting		8	8th speed operation mode	Speed setting	Speed setting	Speed setting	
Setting	Operation mode	Function of signal input																													
		I3	I4	I5																											
1	1st speed operation mode			Free-run stop External forced trip																											
2	2nd speed operation mode	Speed setting		2nd Acc./Dec. time Trip reset																											
4	4th speed operation mode	Speed setting	Speed setting																												
8	8th speed operation mode	Speed setting	Speed setting	Speed setting																											
33	I1/I2 function selection	Signal input functions I1 to I5 can be individually selected.	Free-run stop																												
34	I3 function selection		External forced trip																												
35	I4 function selection		2nd Acc./Dec. time																												
36	I5 function selection		Trip reset																												
3A	Lower speed limit	When speed command selection is set to analog, set the motor speed at 0 V input. 	0 r/min to Upper speed limit [Minimum unit 1 r/min]																												
3b	Upper speed limit	Upper limit of motor command speed.	0 r/min to 4000 r/min [Minimum unit 1 r/min]																												
3C	Torque limit	Set the upper limit of the output torque command. 100 represents the rated torque. [Minimum unit 1]	<table border="1" data-bbox="1083 1942 1365 2005"> <tr> <td>Rated output (W)</td> <td>50, 100, 200, 400</td> <td>750</td> </tr> <tr> <td>Setting range</td> <td>0 to 200</td> <td>0 to 180</td> </tr> </table>	Rated output (W)	50, 100, 200, 400	750	Setting range	0 to 200	0 to 180																						
Rated output (W)	50, 100, 200, 400	750																													
Setting range	0 to 200	0 to 180																													

Parameter No.	Parameter name	Explanation	Setting range
40	O1 function selection	The type of signals from output terminals "O1" and "O2" can be selected. * Do not use it for position detector and positioning.	Trip: ON, Speed is reached to a command value: ON, Running: ON, Free run: ON, CCW run: ON, CW run: ON, Load exceeds 100 %: ON, Speed pulse signal*
41	O2 function selection		
42	O1 output polarity selection	This is a function for inverting the polarity of signal output terminal O1 and O2.	
43	O2 output polarity selection		
44	Speed matching range	"Matching range" of arriving signal can be adjusted.	20 r/min to Upper speed limit [Minimum unit 1 r/min]
45	Output pulse count selection	Set the number of pulses to be output to output terminals "O1" and "O2". • When you use it in more than 3000 r/min, choose values less than 12. • Do not use "the speed pulse" of the output signal (parameter No.45) for position sensing and a positioning use.	1, 2, 3, 4, 6, 8, 12, 24
46	Monitor mode selection	You can choose description to be displayed on 5-digit LED when turning on power.	Rotation speed, Speed command, Internal DC voltage, Load factor, Torque
47	Numerator of display magnification factor	By setting the multiplying factor of a value displayed on 5-digit LED, the rotation speed of gear output shaft and conveyor speed can be displayed.	
48	Denominator of display magnification factor		
4A	Trip history clear	Trip history can be cleared.	
4b to 4F	Trip history 1 to Trip history 5	Trip history for 5 times in the past is stored.	
50	Undervoltage trip selection	You can select whether tripping occurs upon detection of undervoltage.	
51	Retrial selection	Automatic reset in trip (trip retrial) can be set here.	
52	Retrial start time	You can set waiting time until retrial operation is performed after tripping is found.	1 sec to 120 sec [Minimum unit 1 sec]
54	Parameter initializing	Parameters can be initialized to the factory default.	
57	Parameter copy	Parameters can be copied.	
5A	RS485 device number	Set the device number of Amplifier in communication (Amplifier ID)	
5b	RS485 communication speed	Set the communication speed of RS485 communication.	
5C	RS485 communication standard	Set the communication standard of RS485 communication.	
5d	RS485 communication response time	You can set the shortest time necessary to set the RS485 bus to transmission mode to response upon receiving communication data.	
5E	RS485 retry times of communication	Set the retry times of RS485 communication.	
5F	RS485 protocol timeout	You can set the permissible time interval between successively received character codes.	

• How to use Digital key pad

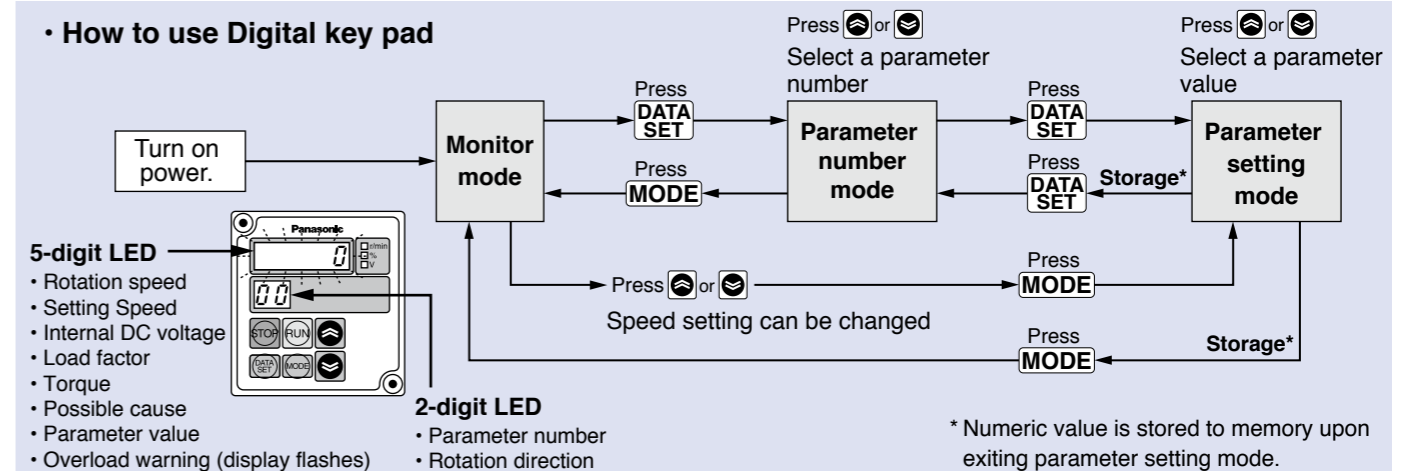

Specification (For Common specification, see p. 27, p. 28)

Size	Model No. / Amplifier and Motor Brushless Amplifier Model number in () is shipped with power connection cable	Motor	Rated output (W)	Input power supply for Amplifier			Rated torque (N·m)	Starting torque (N·m)	Rated speed (r/min)	Maximum rotation speed (r/min)	
				Voltage AC (V)	Allowed range (%)	Frequency (Hz)					Rated input current (A)
38 mm sq.	MBEK5A1BCV (MBEK5A1BCVC) MBEK5A5BCV (MBEK5A5BCVC)	MBMS5AZBL○	50	Single phase 100 to 120	±10	50/60	1.8	0.16	0.30	3000	4000
				Single phase / 3-phase 200 to 240			Single phase 0.9 3-phase 0.5				

* Suffix of "○" in the motor model No. represents shape of shaft. Refer to the "Check the model number" p. 27. * Starting torque: Representative value

Permissible shaft load

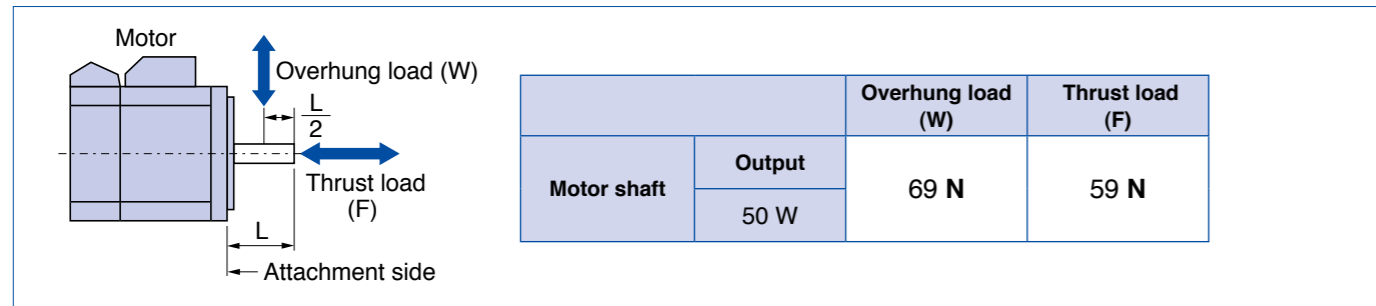

Wiring diagram

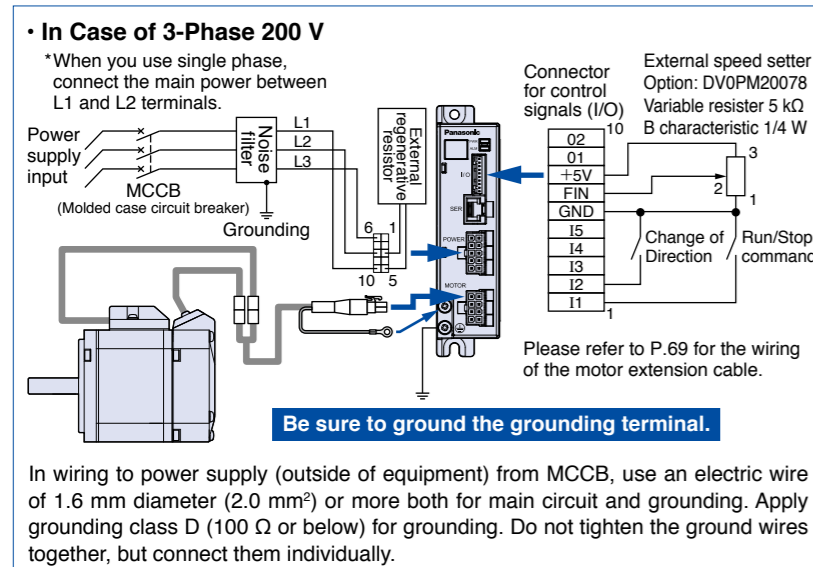

* Please refer to P.95 Support option.

Speed-torque characteristic (Dotted line shows a characteristic curve when supply voltage drops by 10 %)

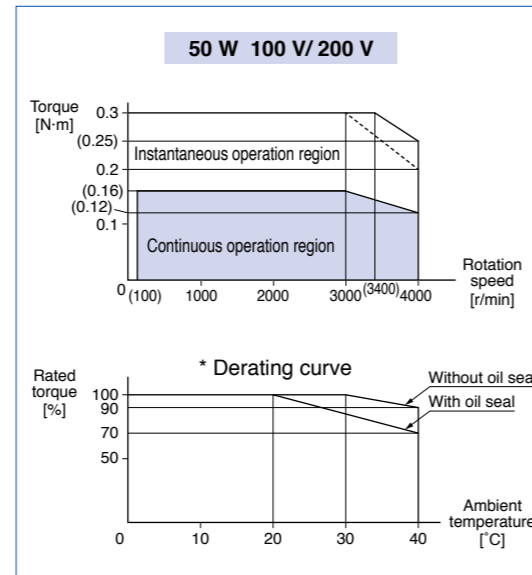

Motor (dimensions)

Unit mm

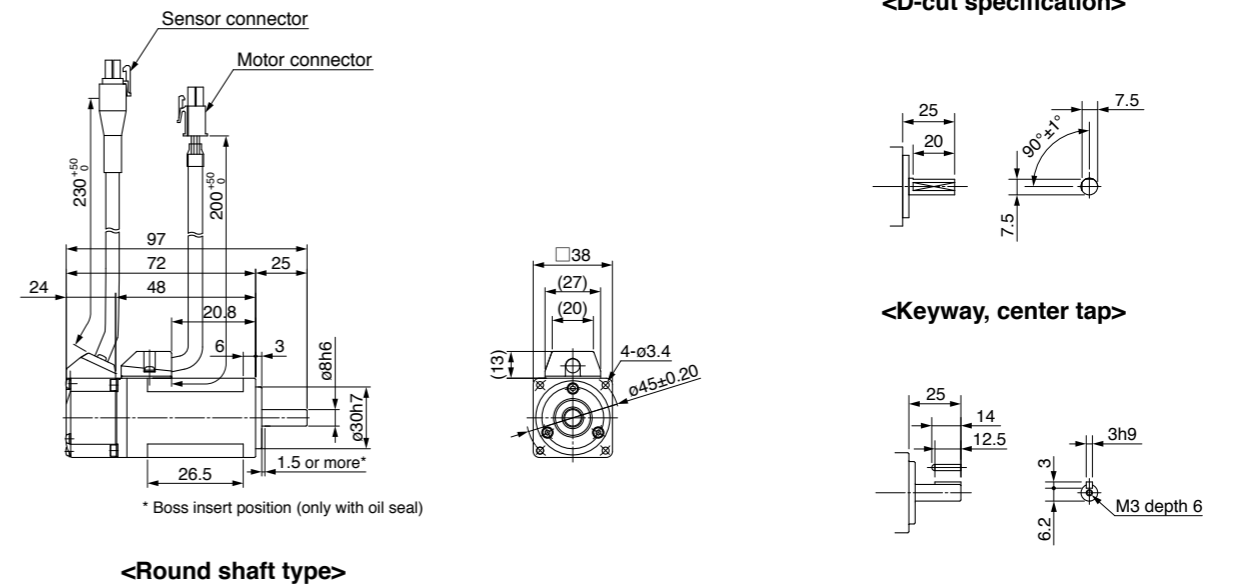

mass
0.32 kg

Brushless amplifier (dimensions)

Unit mm

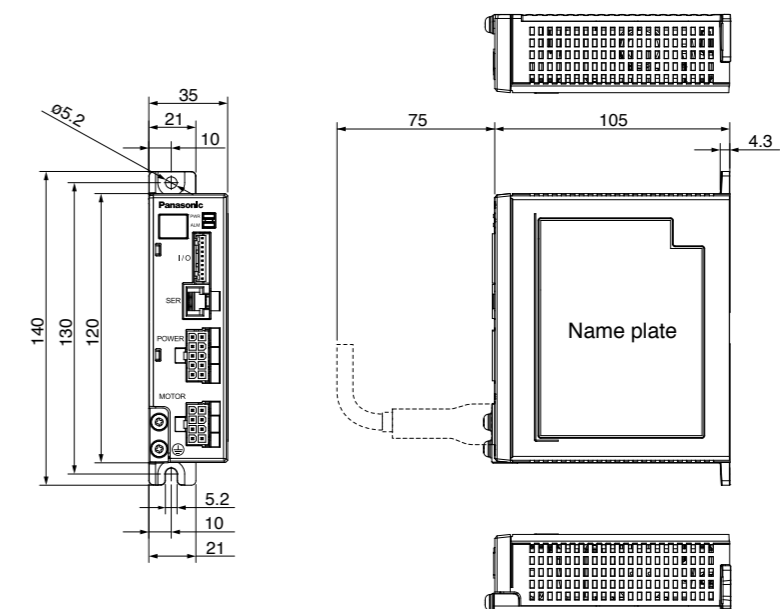

mass
0.37 kg

Specification (For Common specification, see p. 27, p. 28)

Size	Model No. / Amplifier and Motor		Rated output (W)	Input power supply for Amplifier			Rated torque (N·m)	Starting torque (N·m)	Rated speed (r/min)	Maximum rotation speed (r/min)	
	Brushless Amplifier Model number in () is shipped with power connection cable	Motor		Voltage AC (V)	Allowed range (%)	Frequency (Hz)					Rated input current (A)
60 mm sq.	MBEK011BCV (MBEK011BCVC)	MBMS011BL○	100	Single phase 100 to 120	±10	50/60	2.4	0.32	0.70	3000	4000
	MBEK015BCV (MBEK015BCVC)	MBMS012BL○		Single phase 1.3 3-phase 0.7							

* Suffix of "○" in the motor model No. represents shape of shaft. Refer to the "Check the model number" p. 27. * Starting torque: Representative value

Permissible shaft load

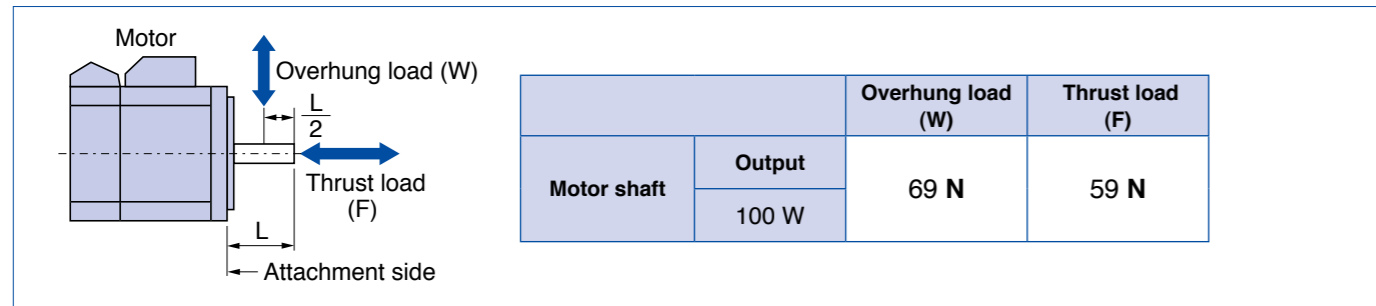

Wiring diagram

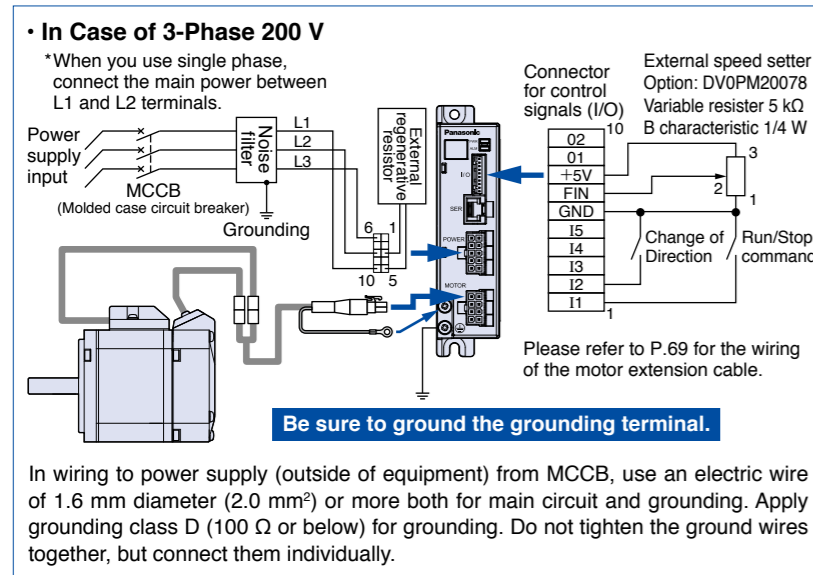

* Please refer to P.95 Support option.

Speed-torque characteristic (Dotted line shows a characteristic curve when supply voltage drops by 10 %)

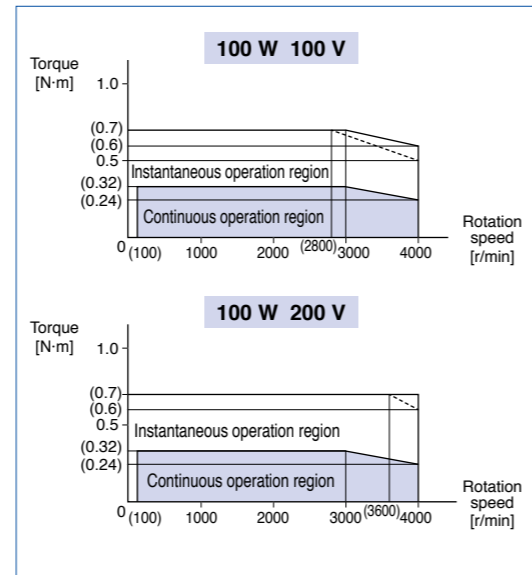

Motor (dimensions)

Unit mm

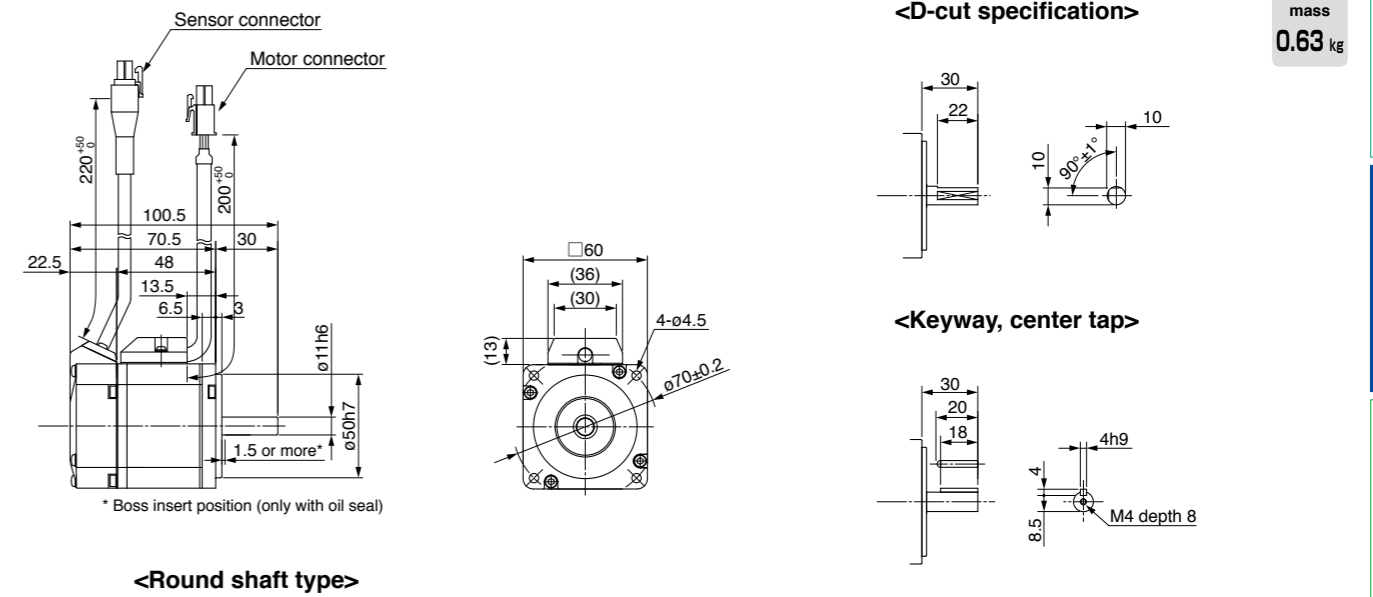

Brushless amplifier (dimensions)

Unit mm

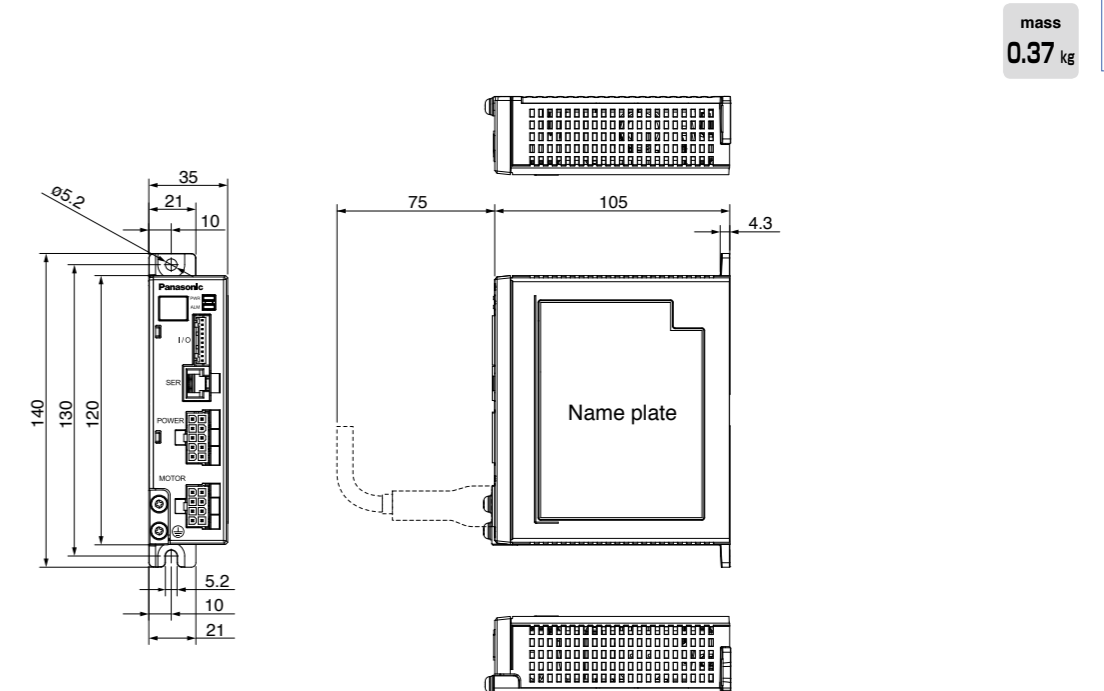

■ Specification (For Common specification, see p. 27, p. 28)

Size	Model No. / Amplifier and Motor		Rated output (W)	Input power supply for Amplifier			Rated torque (N·m)	Starting torque (N·m)	Rated speed (r/min)	Maximum rotation speed (r/min)	
	Brushless Amplifier	Motor		Voltage AC (V)	Allowed range (%)	Frequency (Hz)					Rated input current (A)
60 mm sq.	MBEK021BCV	MBMS021BL○	200	Single phase 100 to 120	±10	50/60	4.2	0.64	1.4	3000	4000
	MBEK025BCV	MBMS022BL○		Single phase 2.1							
			Single phase / 3-phase 200 to 240	3-phase 1.2							

* Suffix of "○" in the motor model No. represents shape of shaft. Refer to the "Check the model number" p. 27. * Starting torque: Representative value

■ Permissible shaft load

Motor shaft	Output	Overhang load (W)	Thrust load (F)
	200 W	245 N	98 N

■ Wiring diagram

• In Case of 3-Phase 200 V

External speed setter
Option: DV0PM20078
Variable resistor 5 kΩ
B characteristic 1/4 W

Connector for control signals (I/O)

Change of Direction / Run/Stop command

External regenerative resistor

Noise filter

Power supply input

MCCB (Molded case circuit breaker)

Grounding

*When you use single phase, connect the main power between L1 and L2 terminals.

Recommended Pin Terminal:
NICHIFU TERMINAL Ind.
TGN TC-1.25-11T

Be sure to ground the grounding terminal.

Please refer to P.69 for the wiring of the motor extension cable.

In wiring to power supply (outside of equipment) from MCCB, use an electric wire of 1.6 mm diameter (2.0 mm²) or more both for main circuit and grounding.

Apply grounding class D (100 Ω or below) for grounding. Do not tighten the ground wires together, but connect them individually.

* Please refer to P.95 Support option.

■ Speed-torque characteristic (Dotted line shows a characteristic curve when supply voltage drops by 10 %)

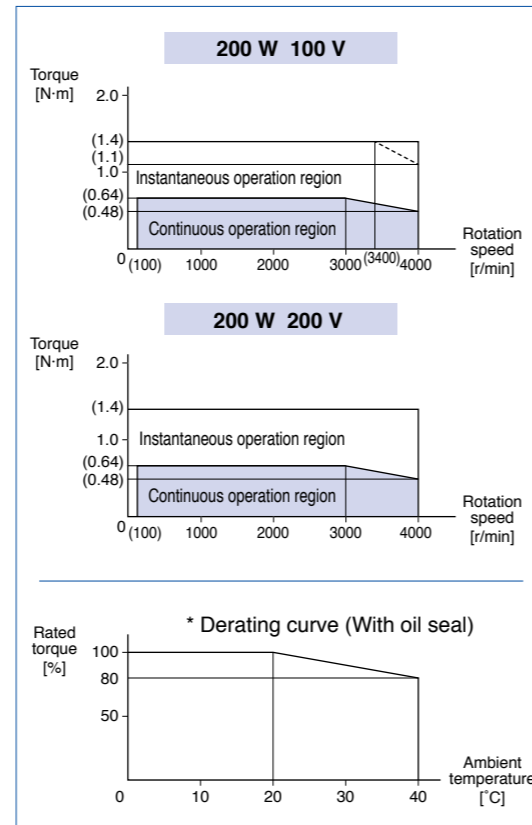

Motor (dimensions)

Unit mm

Sensor connector
Motor connector

<D-cut specification>

mass **0.8 kg**

<Keyway, center tap>

<Round shaft type>

* Boss insert position (only with oil seal)

Brushless amplifier (dimensions)

Unit mm

mass **1.0 kg**

Name plate

* Before using, be sure to read "Instruction manual" to check precautions and correct procedure.

<Cautions> Dimensions are subject to change without notice. Contact us or a dealer for the latest information.

■ Specification (For Common specification, see p. 27, p. 28)

Size	Model No. / Amplifier and Motor		Rated output (W)	Input power supply for Amplifier			Rated torque (N·m)	Starting torque (N·m)	Rated speed (r/min)	Maximum rotation speed (r/min)	
	Brushless Amplifier	Motor		Voltage AC (V)	Allowed range (%)	Frequency (Hz)					Rated input current (A)
60 mm sq.	MBEK045BCV	MBMS042BL○	400	Single phase 200 to 240 3-phase	±10	50/60	Single phase 3.8 3-phase 2.1	1.27	3.0	3000	4000

* Suffix of "○" in the motor model No. represents shape of shaft. Refer to the "Check the model number" p. 27. * Starting torque: Representative value

■ Permissible shaft load

Motor shaft	Output	Overhung load (W)	Thrust load (F)
	400 W	245 N	98 N

■ Wiring diagram

• In Case of 3-Phase 200 V

Please refer to P.69 for the wiring of the motor extension cable.
Be sure to ground the grounding terminal.
 In wiring to power supply (outside of equipment) from MCCB, use an electric wire of 1.6 mm diameter (2.0 mm²) or more both for main circuit and grounding.
 Apply grounding class D (100 Ω or below) for grounding. Do not tighten the ground wires together, but connect them individually.

Connector for control signals (I/O)
 Option: DV0PM20078
 Variable resistor 5 kΩ
 B characteristic 1/4 W

External regenerative resistor
 Noise filter
 Power supply input
 MCCB (Molded case circuit breaker)
 Grounding

*When you use single phase, connect the main power between L1 and L2 terminals.
 Recommended Pin Terminal: NICHIFU TERMINAL Ind. TGN TC-1.25-11T

* Please refer to P.95 Support option.

■ Speed-torque characteristic (Dotted line shows a characteristic curve when supply voltage drops by 10 %)

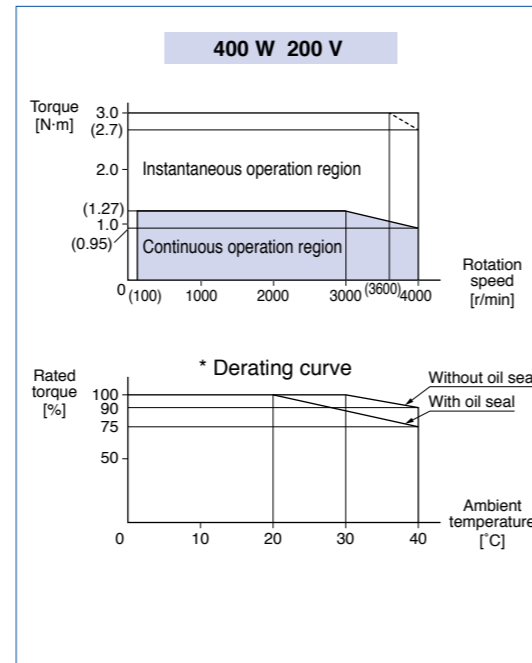

Motor (dimensions)

Unit mm

Sensor connector
 Motor connector

<D-cut specification>

mass **1.2 kg**

<Keyway, center tap>

<Round shaft type>

* Boss insert position (only with oil seal)

Brushless amplifier (dimensions)

Unit mm

mass **1.0 kg**

Name plate

* Before using, be sure to read "Instruction manual" to check precautions and correct procedure.

<Cautions> Dimensions are subject to change without notice. Contact us or a dealer for the latest information.

■ Specification (For Common specification, see p. 27, p. 28)

Size	Model No. / Amplifier and Motor		Rated output (W)	Input power supply for Amplifier				Rated torque (N·m)	Starting torque (N·m)	Rated speed (r/min)	Maximum rotation speed (r/min)
	Brushless Amplifier Model number in () is shipped with power connection cable	Motor		Voltage AC (V)	Allowed range (%)	Frequency (Hz)	Rated input current (A)				
80 mm sq.	MBEK083BCV	MBMS082BL ○	750	3-phase 200 to 240	±10	50/60	4.0	2.4	5.2	3000	4000

* Suffix of "○" in the motor model No. represents shape of shaft. Refer to the "Check the model number" p. 27. * Starting torque: Representative value

■ Permissible shaft load

Motor shaft	Output	Overhung load (W)	Thrust load (F)
	750 W	392 N	147 N

■ Wiring diagram

• In Case of 3-Phase 200 V

Please refer to P.69 for the wiring of the motor extension cable.
Be sure to ground the grounding terminal.
 In wiring to power supply (outside of equipment) from MCCB, use an electric wire of 1.6 mm diameter (2.0 mm²) or more both for main circuit and grounding.
 Apply grounding class D (100 Ω or below) for grounding. Do not tighten the ground wires together, but connect them individually.

Connector for control signals (I/O)
 Option: DV0PM20078
 Variable resistor 5 kΩ
 B characteristic 1/4 W

External regenerative resistor
 Noise filter
 Power supply input
 MCCB (Molded case circuit breaker)
 Grounding

Recommended Pin Terminal:
 NICHIFU TERMINAL Ind.
 TGN TC-1.25-11T

* Please refer to P.95 Support option.

■ Speed-torque characteristic (Dotted line shows a characteristic curve when supply voltage drops by 10 %)

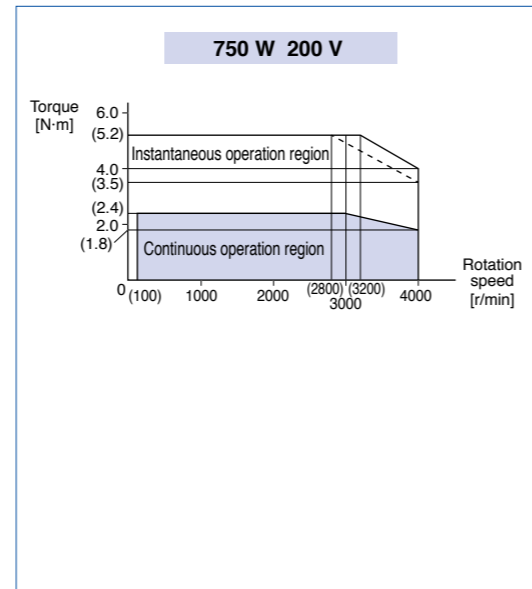

Motor (dimensions)

Unit mm

Sensor connector
 Motor connector
 220^{+0.50}
 147
 112
 86.5
 200^{+0.00}
 35
 25.5
 52.2
 8
 3
 φ19h6
 φ70h7
 1.5 or more*
 80
 (36)
 (30)
 4-φ6
 φ90±0.2
 13
 35
 25
 22
 17.5
 90°±34°
 17.5
 6h9
 6
 15.5
 M5 depth 10

* Boss insert position (only with oil seal)

<Round shaft type>

<D-cut specification>

<Keyway, center tap>

mass **2.3 kg**

Brushless amplifier (dimensions)

Unit mm

6.5
 68
 150
 138
 5.2
 20
 120
 4
 75
 4
 Name plate

mass **1.0 kg**

* Before using, be sure to read "Instruction manual" to check precautions and correct procedure.

<Cautions> Dimensions are subject to change without notice. Contact us or a dealer for the latest information.

MINAS-BL **GP** series

Position Control Type 50 W to 130 W

GP series



• 80 mm square 50 W

Contents	
Check the model number	47
Brushless motor specifications	47
Brushless amplifier specifications	48
System configuration/ System configuration diagram	49
Parameter list of brushless amplifier	51
Example setting of motion pattern	53
Brushless motors – Details	57
Gear head	63

Check the model number

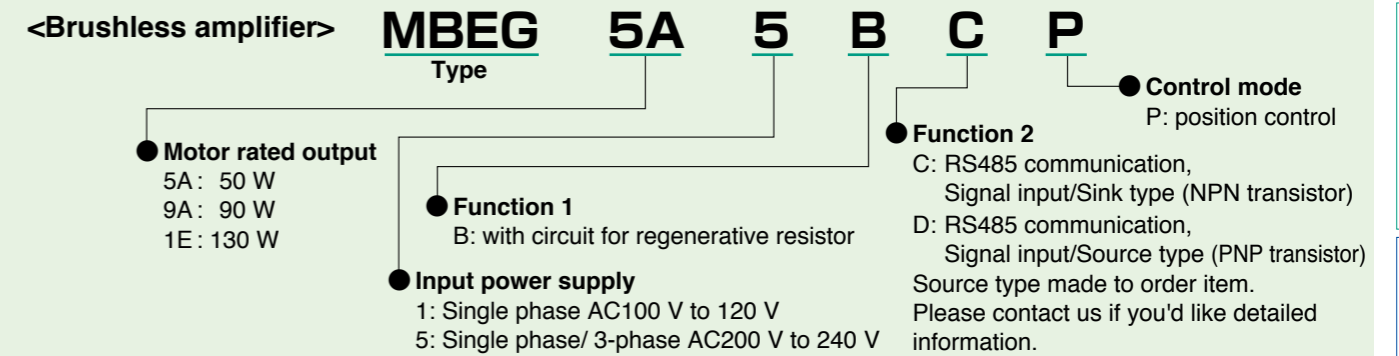
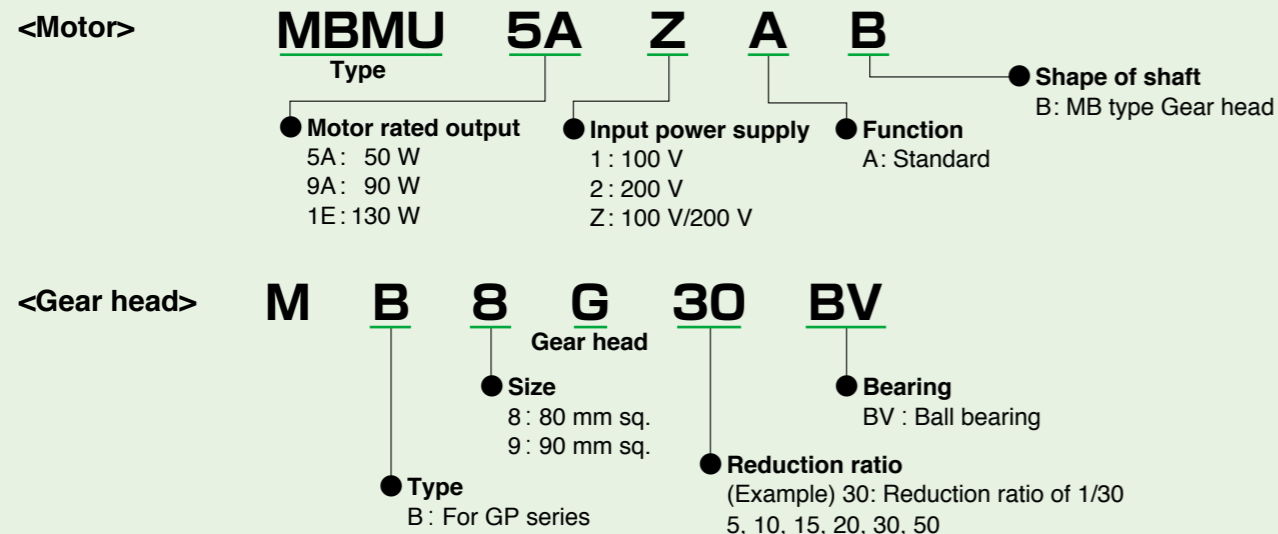

Brushless motor specifications

Item	Specifications				
	80 mm sq.		90 mm sq.		
Motor model No.	MBMU5AZAB	MBMU9A1AB	MBMU9A2AB	MBMU1E1AB	MBMU1E2AB
Motor rated output (W)	50	90		130	
Voltage (V)	for 100/200	for 100	for 200	for 100	for 200
Rated torque (N·m)	0.16	0.29		0.41	
Starting torque ^{*1} (N·m)	0.24	0.43		0.62	
Rated input current (A(rms))	0.53	1.00	0.50	1.30	0.72
Moment of inertia of rotor (×10 ⁻⁴ kg·m ²)	0.12	0.27		0.36	
Rating	Continuous				
Rated rotation speed ^{*2} (r/min)	3000				
Speed control range (r/min)	30 to 4000				
Ambient temperature	-10 °C to +40 °C (free from freezing) * Ambient temperature is measured at a distance of 5 cm from the motor.				
Ambient humidity	20 % to 85 % RH (free from condensation)				
Altitude	Lower than 1000 m				
Vibration	4.9 m/s ² or less X, Y, Z (Center of frame)				
Motor insulation class	130(B)				
Protection structure	IP65 ^{*3,4}				
Number of poles	8				
Motor mass (kg)	0.7	1.0	1.2		

*1 Representative value

*2 Motor shaft speed: to be multiplied by the reduction ratio when the gear head is used.

*3 Excluding the shaft pass-through section and cable end connector.

*4 These motors conform to the test conditions specified in EN standards (EN60529, EN60034-5).

Do not use these motors in application where water proof performance is required such as continuous wash-down operation.

Overload protection characteristics

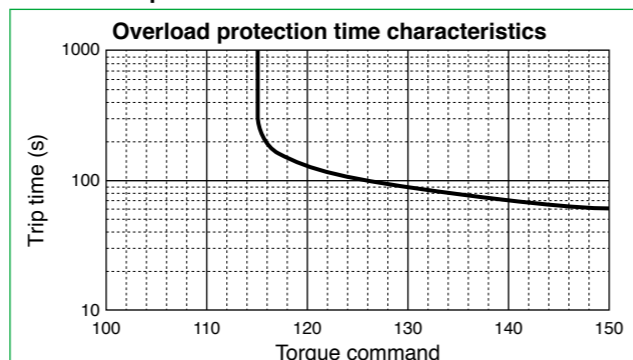

• 100 of the torque command represents the rated torque.

Brushless amplifier specifications (GP series)

Item	Specifications								
	MBEG5A1BCP	MBEG5A5BCP	MBEG9A1BCP	MBEG9A5BCP	MBEG1E1BCP	MBEG1E5BCP			
Amplifier model No.	MBMU5AZAB		MBMU9A1AB	MBMU9A2AB	MBMU1E1AB	MBMU1E2AB			
Applicable Motor	50		90		130				
Motor rated output (W)	50		90		130				
Input power supply voltage (V)	Single phase 100 to 120	Single phase 200 to 240	3-phase 200 to 240	Single phase 100 to 120	Single phase 200 to 240	3-phase 200 to 240	Single phase 100 to 120	Single phase 200 to 240	3-phase 200 to 240
Frequency (Hz)	50/60								
Rated input current (A)	1.5	0.7	0.35	2.2	1.1	0.5	2.8	1.5	0.7
Voltage tolerance	±10 %								
Control method	Position control by CS signal, PWM sine wave driving system								
Ambient temperature	0 °C to +50 °C (free from freezing) * Ambient temperature is measured at a distance of 5 cm from the amplifier.								
Ambient humidity	20 % to 85 % RH (free from condensation)								
Location	Indoor (No corrosive gas, A place without garbage, and dust)								
Altitude	Lower than 1000 m								
Vibration	5.9 m/s ² or less (10 Hz to 60 Hz)								
Protection structure/ Cooling system	Equivalent to IP20/ Self cooling								
Storage temperature	Normal temperature * Temperature which is acceptable for a short time, such as during transportation is -20 °C to 60 °C (free from freezing)								
Storage humidity	Normal humidity								
Number of positioning points	4 points (Travel distance, speed, acceleration time, deceleration time, and relative/absolute can be set per point)								
Positioning resolution	288 pulse/rotation (Accuracy: Within ±5° at 20 °C at no load)								
Signal input	4 inputs								
Signal output	2 outputs (Open collector)								
Communication function	RS485	Max 31 units. Setting of parameter, monitoring of control condition. Communication speed: Choose from 2400 bps/ 4800 bps/ 9600 bps							
	RS232	Setting of parameter and monitoring of control condition are enabled with commercial PC. ^{*1}							
Digital key pad	Parameter change, status monitor, etc. can be executed through the optional Digital key pad DV0P3510. ^{*2}								
Protective function	Warning : Overload warning, Setting change warning Protect : Overload, Overcurrent, Overvoltage, Undervoltage, System error, Over-speed, Sensor error, Overheat, Position error, External forced trip, Position error counter overflow, RS485 communication error, Operation execution error, Homing error, present position overflow, Hardware limit error, Digital key pad communication trouble, user parameter error, and system parameter error								
Regenerating brake	Regenerative braking resistor can be externally connected. ^{*3} Instantaneous braking torque 200 %, Continuous regenerative ability of external regenerative resistor: 10 W (Regenerative operation with which motor shaft is rotated by load, e.g. load lowering operation, should not be continued.)								
Protection level	Protection level: torque command 115 (inverse time characteristics)								
Amplifier mass (kg)	0.37								

*1 PANATERM for BL (Download from our web site.), PC connection cable (DV0P4140), Digital key pad connection cable (DV0P383*0) is required. If your PC does not have RS232 port, use RS232-USB converter.

*2 Digital key pad connection cable (DV0P383*0) is required. *3 Use optional external regenerative resistor (sold separately).

System configuration

Power supply	Rated rotation speed (r/min)	output (W)	Motor	Gear head (Note 1)	Brushless amplifier	Optional parts					
						Brushless amplifier (supplied with power cable) (Note 2)	External regenerative resistor	Noise filter	Surge absorber	Reactor	
						Reference page	p. 74	p. 71	p. 67	p. 67	p. 73
Single phase 100 V	3000	50	MBMU5AZAB	MB8G□BV	MBEG5A1BCP	MBEG5A1BCPC	for 100 V DV0P2890	for single phase power supply DV0P4170	for single phase power supply DV0P4190	for single phase power supply DV0P227	
		90	MBMU9A1AB	MB9G□BV	MBEG9A1BCP	MBEG9A1BCPC					
		130	MBMU1E1AB	MB9G□BV	MBEG1E1BCP	MBEG1E1BCPC					
Single/3-phase 200 V	3000	50	MBMU5AZAB	MB8G□BV	MBEG5A5BCP	MBEG5A5BCPC	for 200 V DV0PM20068	for single phase power supply DV0P4170	for single phase power supply DV0P4190	for single phase power supply DV0P227	
		90	MBMU9A2AB	MB9G□BV	MBEG9A5BCP	MBEG9A5BCPC					
		130	MBMU1E2AB	MB9G□BV	MBEG1E5BCP	MBEG1E5BCPC					for 3-phase power supply DV0PM20042

(Note 1) A figure representing reduction ratio in □.

(Note 2) Refer to p. 74 for a power supply connecting cable.

This part number is the ordering part number for the amplifier and power cable, not for ordering amplifier only.

The supplied power connecting cable is for single-phase input, when supplying three-phase power; please make a cable using optional power connection kit (DV0P2870).

* When installing the reactor, refer to p. 73.

- * Be sure to use a set of matched components (series, power source, capacity, output, etc.)
- * This motor is not provided with a holding brake. If it is used to drive a vertical shaft, the movable section may fall down by its own weight as power is turned off.

Options

Optional parts	Parts number	Reference page
Motor extension cable	1 m DV0PQ1000110	P.69
	3 m DV0PQ1000130	
	5 m DV0PQ1000150	
	10 m DV0PQ10001A1	
Power supply connector kit	DV0P2870	P.70
Digital key pad ¹	DV0P3510	P.68
Digital key pad connection cable	1 m DV0P38310	P.68
	3 m DV0P38330	
	5 m DV0P38350	

Optional parts	Parts number	Reference page
Control signal cable	2 m DV0PM20076	P.70
I/O connector kit	DV0PM20070	P.71
PC connection cable ²	1.5 m DV0P4140	P.70
Noise filter for signal line	DV0P1460	P.67
DIN rail mounting unit	DV0P3811	P.72

* For details of cable, refer to p. 68 to p. 70.

*1 When using Digital key pad, the Digital key pad connection cable (DV0P383*0) is required.

*2 When connecting PC, the PC connection cable (DV0P4140) and the Digital key pad connection cable (DV0P383*0) are required.

Wiring equipment

Selection of circuit breaker (MCCB), magnetic contactor and electric wire. (To check conformity with international standards, refer to p. 93 Conformity with international safety standards.)

Voltage	Power capacity	MCCB Rated current	Magnetic contactor Rated Current (Contact composition)	Core of electric wire (mm ²)	
				Main circuit, Grounding	Control circuit
Single phase 100 V	50 W to 130 W	5 A	20 A (3P+1a)	0.5 (AWG20)	0.13 (AWG26)
Single phase 200 V					
3-phase 200 V					

Be sure to connect the earth terminal to ground.

In wiring to power supply (outside of equipment) from MCCB, use an electric wire of 1.6 mm diameter (2.0 mm²) or more both for main circuit and grounding. Apply grounding class D (100 Ω or below) for grounding.

Selection of relay

A relay used in a control circuit, e.g. at the control input terminal should be small signal relay (Min. guaranteed current 1 mA or less) for positive contact.

<Example> Panasonic: DS type, HC type OMRON: G2A type

Selection of control circuit switch

When using a switch in place of relay, select a switch rated at minute electric current, to assure positive contact.

<Example> Nihon Kaiheiki Ind.: M-2012J-G

The wiring of SER and I/O connector

The wiring of SER and I/O connector should separate from power line to prevent malfunction.

Wiring to the I/O connector

Permissible length for control signal cable is 5 m or less.

System configuration diagram

Example of digital setting (Digital key pad)

- Various key operation, Homing, Teaching
- Digital Monitor [Rotation speed, Present position, Internal DC Voltage, Load factor, Torque, Trip history, Overload warning (flashing)]
- Set/change parameters
- Storage of the parameters (read, write)

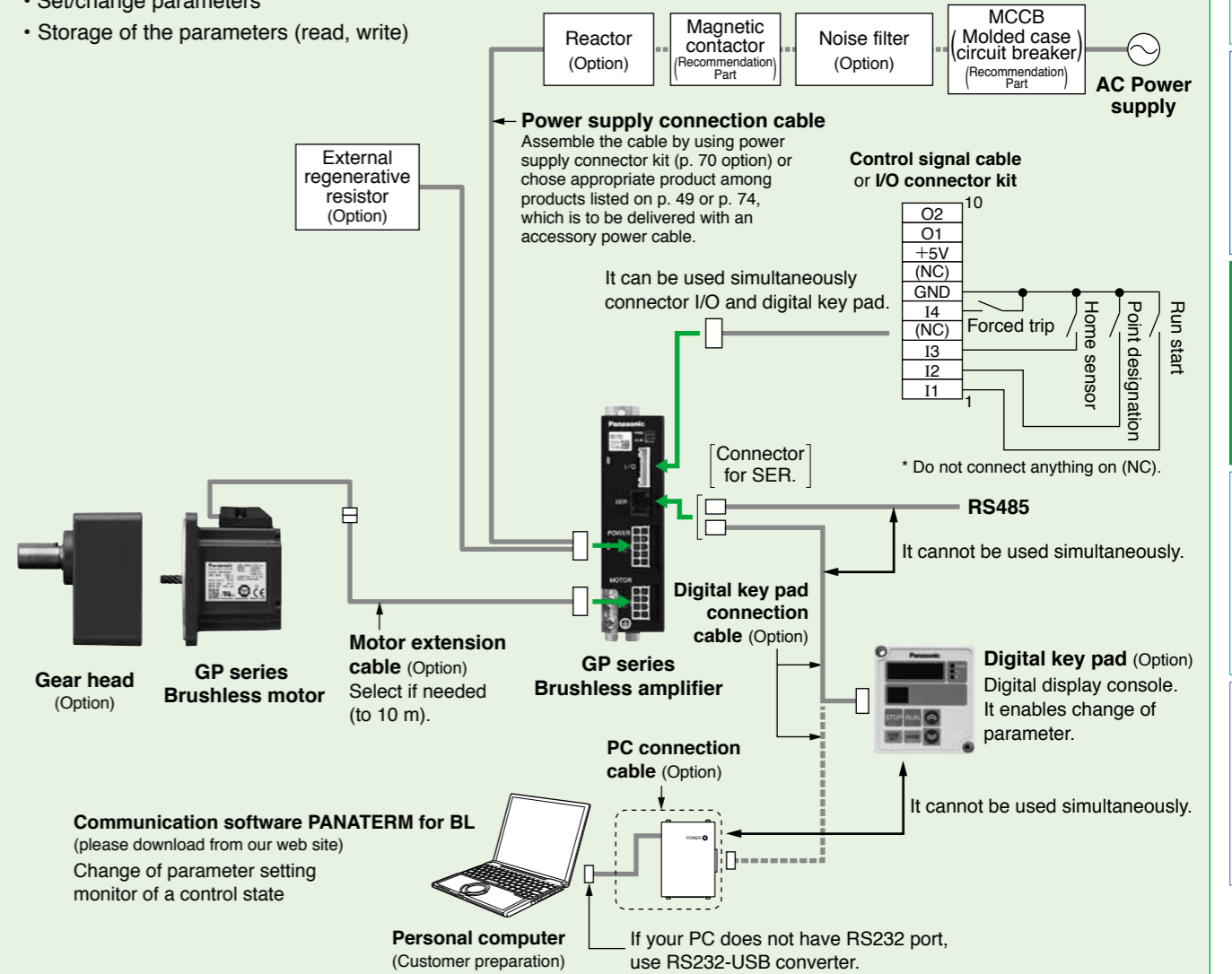

How to use Digital key pad

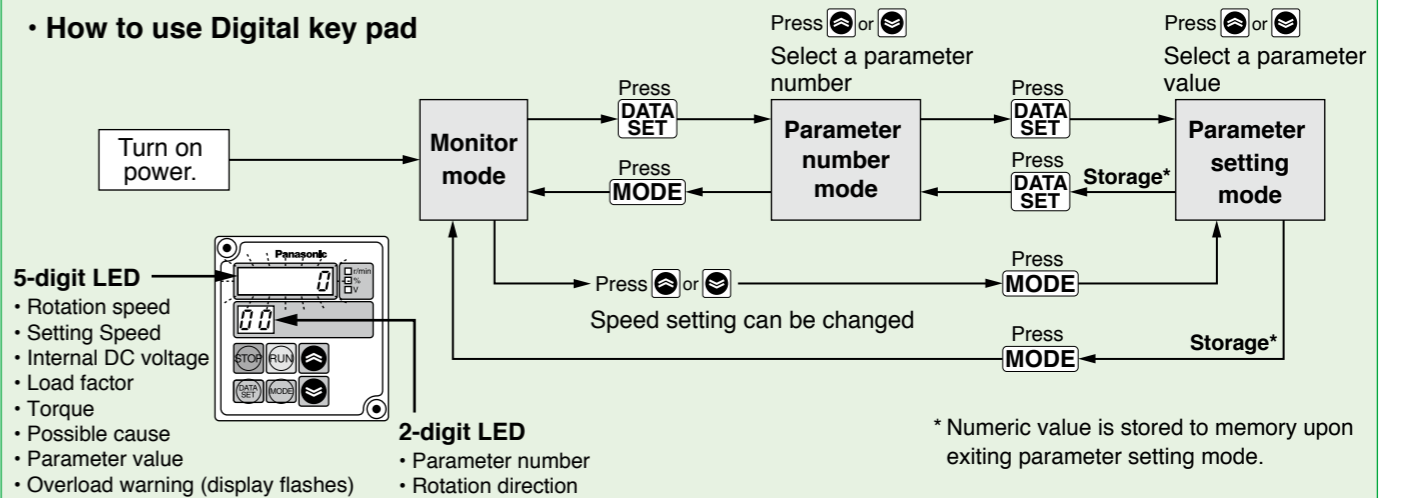

* Please refer to the operation manual overall on how to operate the teaching.

Please download the operation manual from our web site below.

<http://industrial.panasonic.com/ww/products/motors-compressors/fa-motors>

Parameter list of brushless amplifier

Parameter No.	Parameter name	Explanation	Setting range
00	The 1st target position (rotation number)	You can set travel distance in rotation numbers and pulses.	-16384 to 16383
01	The 1st target position (Pulse)	(288 pulses per rotation)	-288 to 288
02	The 1st coordinate setting	You can select positioning system to the 1st point. 0: Relative travel, 1: Absolute travel	0, 1
03	The 1st setting speed (r/min)	You can set the speed moving to the 1st point.	0 to 4000
04	The 1st acceleration time (ms)	You can set time taken for reaching the 1st setting speed.	1 to 30000
05	The 1st deceleration time (ms)	You can set time taken from the 1st setting speed to stop.	1 to 30000
06	The 1st block setting	0: Normal operation 1: Continuous block operation (1st point → 2nd point) 2: Combined block operation (1st point + 2nd point)	0 to 2
07	The 1st block timer setting (ms)	Start commanding of 2nd point after this setting time elapses and command of 1st point is completed.	0 to 30000
08	The 2nd target position (rotation number)	You can set travel distance in rotation numbers and pulses.	-16384 to 16383
09	The 2nd target position (pulse)	(288 pulses per rotation)	-288 to 288
0A	The 2nd coordinate setting	You can select positioning system to the 2nd point. 0: Relative travel, 1: Absolute travel	0, 1
0b	The 2nd setting speed (r/min)	You can set the speed moving to the 2nd point.	0 to 4000
0C	The 2nd acceleration time (ms)	You can set time taken for reaching the 2nd setting speed.	1 to 30000
0d	The 2nd deceleration time (ms)	You can set time taken from the 2nd setting speed to stop.	1 to 30000
0E	The 2nd block setting	0: Normal operation, 1: Continuous block operation (2nd point → 3rd point)	0, 1
0F	The 2nd block timer setting (ms)	Start commanding of 3rd point after this setting time elapses and command of 2nd point is completed.	0 to 30000
10	The 3rd target position (rotation number)	You can set travel distance in rotation numbers and pulses.	-16384 to 16383
11	The 3rd target position (Pulse)	(288 pulses per rotation)	-288 to 288
12	The 3rd coordinate setting	You can select positioning system to the 3rd point. 0: Relative travel, 1: Absolute travel	0, 1
13	The 3rd setting speed (r/min)	You can set the speed moving to the 3rd point.	0 to 4000
14	The 3rd acceleration time (ms)	You can set time taken for reaching the 3rd setting speed.	1 to 30000
15	The 3rd deceleration time (ms)	You can set time taken from the 3rd setting speed to stop.	1 to 30000
16	The 3rd block setting	0: Normal operation, 1: Continuous block operation (3rd point → 4th point) 2: Combined block operation (3rd point + 4th point)	0 to 2
17	The 3rd block timer setting (ms)	Start commanding of 4th point after this setting time elapses and command of 3rd point is completed.	0 to 30000
18	The 4th target position (rotation number)	You can set travel distance in rotation numbers and pulses.	-16384 to 16383
19	The 4th target position (Pulse)	(288 pulses per rotation)	-288 to 288
1A	The 4th coordinate setting	You can select positioning system to the 4th point. 0: Relative travel, 1: Absolute travel	0, 1
1b	The 4th setting speed (r/min)	You can set the speed moving to the 4th point.	0 to 4000
1C	The 4th acceleration time (ms)	You can set time taken for reaching the 4th setting speed.	1 to 30000
1d	The 4th deceleration time (ms)	You can set time taken from the 4th setting speed to stop.	1 to 30000
1E	The 4th block setting	0: Normal operation, 1: Continuous block operation (4th point → 1st point)	0, 1
1F	The 4th block timer setting (ms)	Start commanding of 1st point after this setting time elapses and command of 4th point is completed.	0 to 30000
20	Acceleration mode	You can select running pattern in acceleration.	0, 1
21	Deceleration mode	You can select running pattern in deceleration.	0, 1
22	Sequential run maximum point number	You can set the maximum point number for positioning by use of sequential run signal.	1 to 4
23	Coordinate system setting	0: CCW rotation in + direction, 1: CW rotation in + direction	0, 1
28	Position loop gain (the 1st gain)	You can determine the response of position control.	0 to 100
29	Velocity loop gain (the 1st gain)	You can determine the response of velocity loop.	0 to 10000
2A	Velocity loop integration gain (the 1st gain)	You can determine the rigidity of velocity loop.	0 to 10000
2b	Velocity feed forward gain (the 1st gain) (%)	This is the function to forward (add) position command to speed command.	0 to 100
2C	Speed detection filter (the 1st gain)	You can set the time constant of low-pass filter of speed feedback.	5 to 20
2d	Velocity feed forward-timeconstant (Common to the 1st/2nd gain) (ms)	This is a filter in velocity feed forward section.	0 to 500
2E	Torque limit setting (the 1st gain)	Output torque of motor is limited.	50 to 150
2F	Torque filter-timeconstant (Common to the 1st/2nd gain)	You can set the time constant of primary delay filter of torque instruction.	0 to 500
30	The 2nd position loop gain (the 2nd gain)	You can determine the response of position control.	0 to 100
31	The 2nd velocity loop gain (the 2nd gain)	You can determine the response of velocity loop.	0 to 10000
32	The 2nd velocity loop integration gain (the 2nd gain)	You can determine the rigidity of velocity loop.	0 to 10000
33	The 2nd velocity feed forward gain (the 2nd gain) (%)	Set it at 0 in normal use. This is the function to forward (add) position command to speed command during on the 2nd gain.	0 to 100
34	The 2nd speed detection filter (the 2nd gain)	Use the default setting normally. You can set the time constant of low-pass filter in speed feedback.	5 to 20
35	The 2nd torque limit setting (the 2nd gain) (%)	Output torque of the motor is limited.	50 to 150
36	Gain switching mode selection	0: Fixed at the 1st gain, 1: Fixed at the 2nd gain 2: Automatic switching (In running = the 2nd gain, In standstill = the 1st gain)	0 to 2
37	Gain switching time (ms)	When the gain switching mode is set to automatic switching, after the output of instruction, the 2nd gain (in running) changes to the 1st gain (in standstill) when time setting has elapsed.	0 to 10000

Parameter No.	Parameter name	Explanation	Setting range
38	In-position range	In-position signal is turned on when position error (difference between command position and actual position) is below setting.	0 to 16383
39	Position error set-up	Abnormal detect when deviation value exceeds the set value × 8.	0 to 16383
3A	Position error invalidation	0: Effective, 1: Ineffective (Motor does not trip but keeps on operating.)	0, 1
3E	Run-command selection	You can select the run-command. 0: I/O, 1: RS485	0, 1
40	Homing mode	Select homing method.	0 to 5
41	Homing direction	You can set the detection direction of home.	0, 1
42	Homing speed (r/min)	You can set the speed in homing action.	0 to 4000
43	Homing limit	Sets the limit of the amount of movement during homing. Homing error detect if travel distance has exceeded this setting.	0 to 16383
44	Homing acceleration/deceleration time (ms)	You can set time taken for reaching the homing speed.	1 to 30000
45	Bumping torque detection value (%)	You can limit the output torque of motor when returning to bumping home.	50 to 150
46	Bumping detection time (ms)	You can set the detection time of bumping toque in returning to bumping home.	0 to 15000
47	Home offset (pulse)	You can set the offset from home detection position.	-16384 to 16383
48	Homing function	0: Required, 1: Not required (Position when power is turned on is the home.) 2: When homing is not completed yet, homing operation is executed by positioning start signal.	0 to 2
49	Homing selection when motor is free	0: When homing is unavailable after motor free state is reset (when trip occurs, after trip is reset), positioning operation is enabled. 1: When motor is free (trip occurs), homing is required again.	0, 1
4A	Present position overflow permission	You can set operation when the present position counter of motor has overflowed (exceeded ±32767 rotations). 0: Prohibited (motor trip), 1: Permitted (no motor trip)	0, 1
4b	Jog speed (r/min)	You can set the operation speed in jog operation.	0 to 4000
4C	Jog acceleration time (ms)	You can set time taken for reaching jog speed.	1 to 30000
4d	Jog deceleration time (ms)	You can set time taken from jog speed until stopping.	1 to 30000
4E	Teaching speed (r/min)	You can set speed used in applying teaching function of Digital key pad.	0 to 4000
50	I1 function selection	You can assign functions to I1 through I4. 0: Forced trip, 1: Instantaneous stop, 2: Deceleration stop	0 to 15
51	I2 function selection	3: Homing start, 4: Forward jog, 5: Reverse jog, 6: Point designation 1	
52	I3 function selection	7: Point designation 2, 8: Run start, 9: Sequential run start	
53	I4 function selection	10: Trip reset, 11: Home sensor, 12: Limit in + direction	
54	I1 Input logic selection	13: Limit in - direction, 14: Direction switching, 15: Motor-free	
55	I2 Input logic selection	0: Normal logic (Input is effective (ON) when connected to GND.)	0, 1
56	I3 Input logic selection	1: Reverse rotation logic (Input is effective (ON) when OPEN (open))	
57	I4 Input logic selection	Set the reverse rotation logic to the input desired to be operated on wiring break side such as forced trip (emergency stop input).	
58	Trip reset function enable	0: Disable, 1: Enable (Operation start signal longer than 1 second enables execution of trip reset.)	
59	Deceleration time in instantaneous stop (ms)	Set the deceleration time in executing instantaneous stop.	0 to 30000
5C	O1 function selection	You can assign functions to O1 and O2. 0: Trip output, 1: In-position, 2: In-motion signal (BUSY)	0 to 5
5d	O2 function selection	3: Homing completion, 4: Overload detection, 5: Torque under restriction	
5E	O1 output polarity selection	0: Normal logic (Output transistor ON at enabled, OFF at disabled)	0, 1
5F	O2 output polarity selection	1: Reversed logic (Output transistor OFF at enabled, ON at disabled) When only trip output is normal logic, output transistor is off in tripping, and output transistor is on in no tripping.	
60	RS485 device number	Set the device number of amplifier in communication (Amplifier ID).	128 to 159 (80h to 9Fh)
61	RS485 communication speed	Set the communication speed of RS485 communication.	0 to 2
62	RS485 communication standard	Set the communication standard of RS485 communication.	0 to 11
63	RS485 communication response time (ms)	Communication response time is the shortest time for setting transmission mode in RS485 bus for response after the amplifier has received communication data.	10 to 100
64	RS485 retry times of communication	Set the retry times of RS485 communication.	0 to 9
65	RS485 protocol timeout (seconds)	Protocol timeout is the time allowed from reception of a character code to reception of the next one in communication.	1 to 255
6A	Trip history clear	When "(yes)" is set, trip history (Pr6b to 6F) is cleared.	0(No), 1(Yes)
6b	Trip history 1	Display the latest trip.	—
6C	Trip history 2	Display the 2nd latest trip.	—
6d	Trip history 3	Display the 3rd latest trip.	—
6E	Trip history 4	Display the 4th latest trip.	—
6F	Trip history 5	Display the 5th latest trip.	—
77	Parameter copy function	This function is only available with use of the Digital key pad.	No/P.INIT/ P.LOAD/P.PROG
7A	Monitor mode switching	You can choose monitor screen to be displayed first when the Digital key pad is connected.	0 to 6
7b	Numerator of command pulse ratio	You can set the division multiplier ratio of travel distance.	1 to 20000
7C	Denominator of command pulse ratio		
7F	For manufacturer use	It cannot be changed.	—

Example setting of motion pattern

Indexing (feeding by fixed length)

- When feeding by fixed length of travel

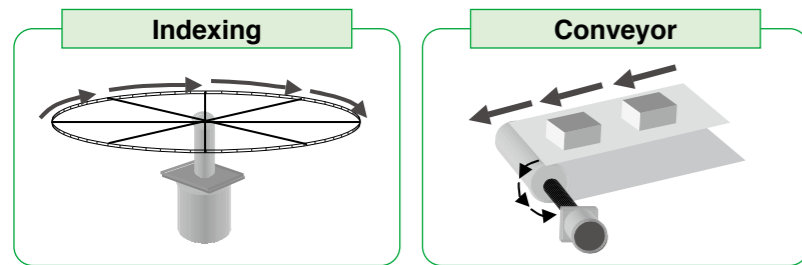

<Example of setting>

- Every time I1 is turned on, the motor runs for fixed travel distance.
- Homing operation is executed and the home is set when I1 is turned on just once after power-on. (It is also possible to set power-on position to the home.)

[Signal function setting]

Terminal symbol	Terminal number	Terminal name	Description of function
I1	1	Signal input 1	Operates when "I1" and "GND" are shorted (Homing operation for the first time after power-on)
I2	2	Signal input 2	CW operation when "I2" and "GND" are shorted, CCW operation when they are opened (including homing operation mode)
I3	11	Signal input 3	Motor trips when "I3" and "GND" are open.
I4	4	Signal input 4	Home detected when "I4" and "GND" are shorted.
O1	6	Signal output 1	Trip output (Normally on, and off in tripping)
O2	12	Signal output 2	In motion signal (including homing operation)

[Operation timing chart]

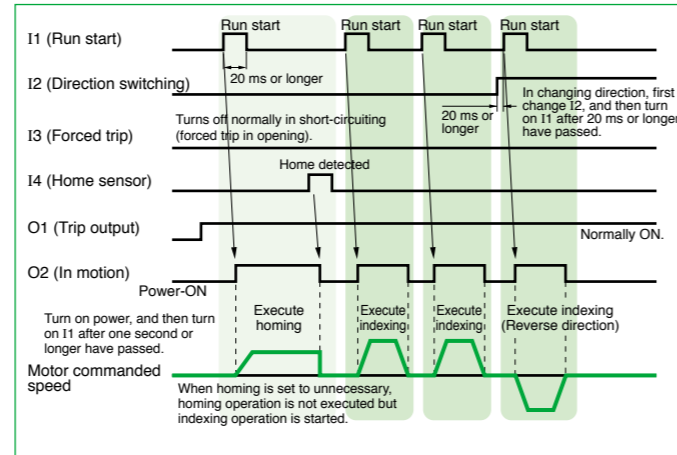

[Parameter setting] Indicates only the point changed from default setting. (Parameter marked with * is effective after power resetting.)

Function	Parameter No. (Pr□□)	Name of parameter	Setting	Remarks
Selection of signal function	50*	I1 function selection	8	Run start (used only for the 1st point)
	51*	I2 function selection	14	Direction switching input
	52*	I3 function selection	0	Forced trip input
	53*	I4 function selection	11	Home sensor input
	56*	I3 input logic selection	1	Changes the polarity of 3 to effective when open (forced trip in this case).
	5C	O1 function selection	0	Trip output
	5d	O2 function selection	2	In-motion signal
Homing function	40	Homing mode	0, 1, 5	Set homing in which to use home sensor.
	41	Homing direction	0, 1	Set any desired homing direction.
	42	Homing speed	200	Set any desired operation speed.
	44	Homing acceleration/deceleration time	200	Set any desired acceleration/deceleration time.
	48*	Homing function	2	Set to 1 when setting power-on position to the home.
	49	Selecting homing when motor is free	1	Set to 1 (homing is required again when tripping occurs.)
The 1st point (indexing length)	4A	Present position overflow permission	1	Set to 1 (permits overflow).
	00	The 1st target position (rotation number)	10	Set the travel distance by rotation number and pulse (one rotation per 288 pulses).
	01	The 1st target position (pulse)	0	When the setting does not represent proper mechanical reduction gear ratio, accumulated error occurs, which results in dislocation.
	02	The 1st coordinate setting	0	Set relative travel.
	03	The 1st setting speed	2000	Set any desired operation speed.
	04, 05	The 1st acceleration time/ The 1st deceleration time	200	Set any desired acceleration time and deceleration time.
06	The 1st block setting	0	Set normal operation.	

<Information>

In this setting, I3 is set to forced trip when open. Connect an emergency stop switch or the like which is shorted but open at error to I3 terminal.

Please note that the motor will not run due to forced trip without such connection.

Reciprocating

- When executing reciprocating run between fixed positions

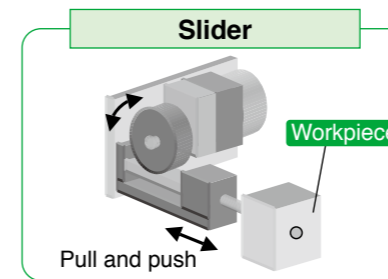

<Example of setting>

- Every time I1 is turned on, feed action → return action → feed action is repeated in turn.
- When power is on, homing operation is executed and home is set by I1.

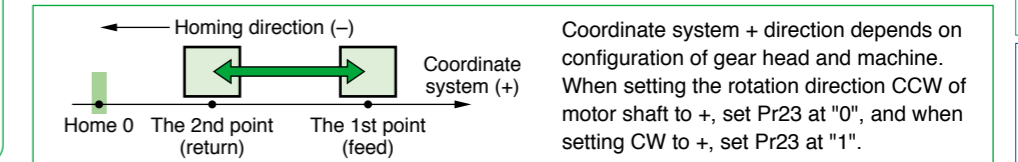

[Signal function setting]

Terminal symbol	Terminal number	Terminal name	Description of function
I1	1	Signal input 1	Operates when "I1" and "GND" are shorted (Homing operation for the first time after power-on)
I2	2	Signal input 2	Home detected when "I2" and "GND" are shorted.
I3	11	Signal input 3	Operation stops when "I3" and "GND" are shorted.
I4	4	Signal input 4	Motor trips when "I4" and "GND" are open.
O1	6	Signal output 1	Trip output (Normally on, and off in tripping)
O2	12	Signal output 2	In motion signal (including homing operation)

[Operation timing chart]

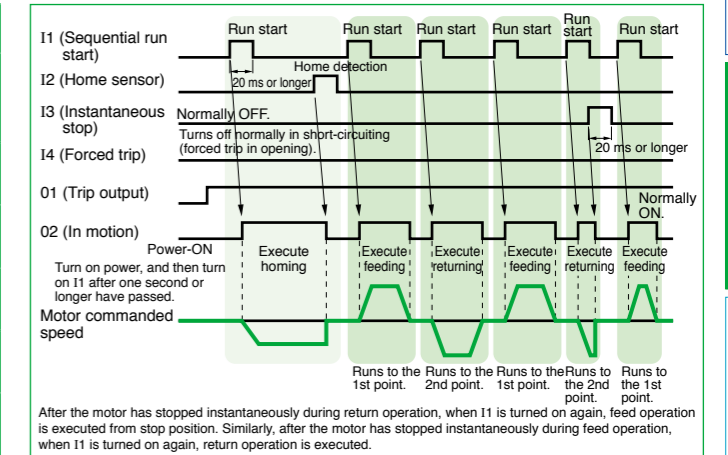

[Parameter setting] Indicates only the point changed from default setting. (Parameter marked with * is effective after power resetting.)

Function	Parameter No. (Pr□□)	Name of parameter	Setting	Remarks
Selection of signal function	50*	I1 function selection	9	Sequential run start
	51*	I2 function selection	11	Home sensor input
	52*	I3 function selection	1	Instantaneous stop input
	53*	I4 function selection	0	Forced trip input
	57*	I4 input logic selection	1	Changes the polarity of I4 to effective when open (forced trip in this case).
	5C	O1 function selection	0	Trip output
	5d	O2 function selection	2	In-motion signal
Homing function	40	Homing mode	0	Set homing in which to use home sensor.
	41	Homing direction	1	Set the homing direction normally to minus direction (return direction).
	42	Homing speed	200	Set any desired operation speed.
	44	Homing acceleration deceleration time	200	Set any desired acceleration/deceleration time.
	48*	Homing function	2	Homing operation by initial I1 input when power is turned on.
	49	Selecting homing when motor is free	0	Homing is not required when tripping occurs.
The 1st point (feed position)	4A	Present position overflow permission	0	Overflow is not permitted because absolute travel is set.
	23*	Coordinate system setting	0, 1	Set so that homing is in minus direction.
	00	The 1st target position (rotation number)	10	Set the feed position coordinates.
	01	The 1st target position (pulse)	0	
	02	The 1st coordinate setting	1	Set absolute travel.
	03	The 1st setting speed	2000	Set any desired travel.
The 2nd point (return position)	04, 05	The 1st acceleration time/ The 1st deceleration time	200	Set any desired acceleration time and deceleration time.
	06	The 1st block setting	0	Set normal operation.
	08	The 2nd target position (rotation number)	2	Set the return position coordinate.
	09	The 2nd target position (pulse)	0	(Set 0 when the position is the same as home.)
	0A	The 2nd coordinate setting	1	Set absolute travel.
	0b	The 2nd setting speed	2000	Set any desired travel.
Others	0C, 0d	The 2nd acceleration time/ The 2nd deceleration time	200	Set any desired acceleration time and deceleration time.
	0E	The 2nd block setting	0	Set normal operation.
	22	Sequential run Maximum point number	2	Restricts the maximum point number in sequential operation. When this parameter is set to 2, whenever I1 is turned on, system operates in turn from the 1st point → the 2nd point → the 1st point ...

Example setting of motion pattern

Automatic reciprocating

• When executing fixed reciprocating sequence operation with single run start signal

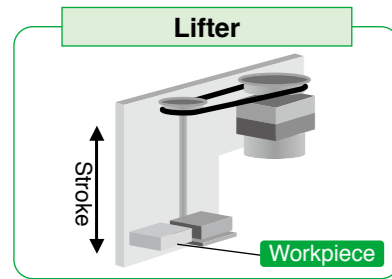

<Example of setting>

- When I1 is turned on, the unit moves to target position (feed position), waits for a specified time, and returns to original position (return position).
- When power is on, homing operation is executed and home is set by I1.

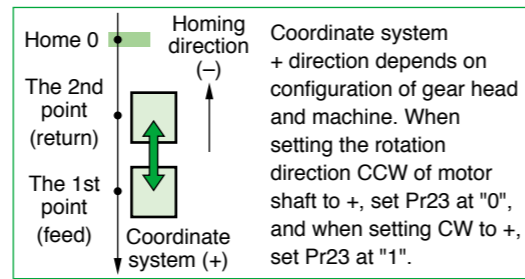

[Signal function setting]

Terminal symbol	Terminal number	Terminal name	Description of function
I1	1	Signal input 1	Operates when "I1" and "GND" are shorted (Homing operation for the first time after power-on)
I2	2	Signal input 2	Home detected when "I2" and "GND" are shorted.
I3	11	Signal input 3	Operation stops when "I3" and "GND" are shorted. (Motor does not operate during short-circuit.)
I4	4	Signal input 4	Motor trips when "I4" and "GND" are open.
O1	6	Signal output 1	Trip output (Normally on, and off in tripping)
O2	12	Signal output 2	In motion signal (including homing operation)

[Operation timing chart]

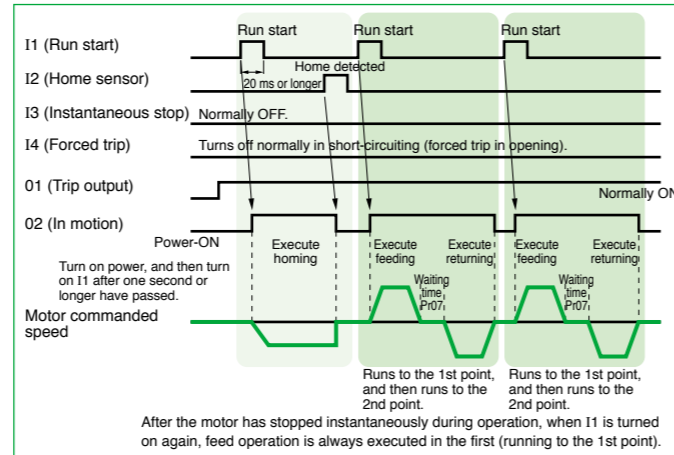

[Parameter setting] Indicates only the point changed from default setting. (Parameter marked with * is effective after power resetting.)

Function	Parameter No. (Pr□□)	Name of parameter	Setting	Remarks
Selection of signal function	50*	I1 function selection	8	Run start
	51*	I2 function selection	11	Home sensor input
	52*	I3 function selection	1	Instantaneous stop input
	53*	I4 function selection	0	Forced trip input
	57*	I4 input logic selection	1	Changes the polarity of I4 to effective when open (forced trip in this case).
	5C	O1 function selection	0	Trip output
	5d	O2 function selection	2	In-motion signal
Homing function	40	Homing mode	0	Set homing in which to use home sensor.
	41	Homing direction	1	Set the homing direction normally to minus direction (return direction).
	42	Homing speed	200	Set any desired operation speed.
	44	Homing acceleration/deceleration time	200	Set any desired acceleration/deceleration time.
	48*	Homing function	2	Homing operation by initial I1 input when power is turned on.
	49	Selecting homing when motor is free	0	Homing is not required when tripping occurs.
	4A	Present position overflow permission	0	Overflow is not permitted because absolute travel is set.
The 1st point (feed position)	23*	Coordinate system setting	0, 1	Set so that homing is in minus direction.
	00	The 1st target position (rotation number)	10	Set the feed position coordinates.
	01	The 1st target position (pulse)	0	
	02	The 1st coordinate setting	1	Set absolute travel.
	03	The 1st setting speed	2000	Set any desired operation speed.
	04, 05	The 1st acceleration time/ The 1st deceleration time	200	Set any desired acceleration/deceleration time.
	06	The 1st block setting	1	Execute running to the 2nd point, after executing running to the 1st point.
The 2nd point (return position)	07	The 1st block timer setting	500	The 2nd point operation is started in 500 ms.
	08	The 2nd target position (rotation number)	2	Set the return position coordinate.
	09	The 2nd target position (pulse)	0	(Set 0 when the position is the same as home.)
	0A	The 2nd coordinate setting	1	Set absolute travel.
	0b	The 2nd setting speed	2000	Set any desired operation speed.
	0C, 0d	The 2nd acceleration time/ The 2nd deceleration time	200	Set any desired acceleration/deceleration time.
	0E	The 2nd block setting	0	Set normal operation.
0F	The 2nd block timer setting	0	Ineffective because 0E is 0.	

Door opening/closing

• When executing reciprocating operation between 2 points

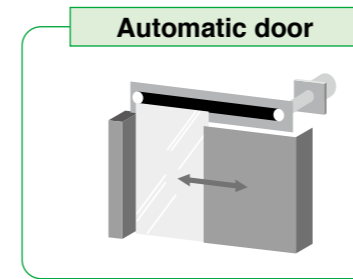

<Example of setting>

- When open/close is chosen and I1 is input, open/close operation is executed.
- When the door is stopped in any position on the way of action, opening or closing operation is enabled from such position. (It is the same when the door is moved by hand with motor disabled.)
- Use of bumping homing enables elimination of home sensor.
- Holding torque when motor is stopped can be changed.

• Coordinate system + direction depends on configuration of gear head and machine. When setting the rotation direction CCW of motor shaft to +, set Pr23 at "0", and when setting CW to +, set Pr23 at "1".

• When setting the Mechanical end offset value to -144, the Home is the point which has moved 144 pulses to the + direction seen from the Mechanical end.

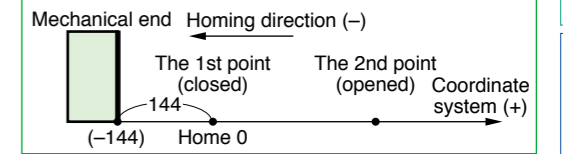

[Signal function setting]

Terminal symbol	Terminal number	Terminal name	Description of function
I1	1	Signal input 1	Operates when "I1" and "GND" are shorted (Homing operation for the first time after power-on)
I2	2	Signal input 2	Opening (point 2) operation when "I2" and "GND" are shorted, and closing (point 1) operation when they are open.
I3	11	Signal input 3	Motor is free when "I3" and "GND" are open. (Servo lock released)
I4	4	Signal input 4	Operation is stopped when "I4" and "GND" are open. (Motor is not activated while they are open.)
O1	6	Signal output 1	Trip output (Normally on, and off in tripping)
O2	12	Signal output 2	In motion signal (including homing operation)

[Operation timing chart]

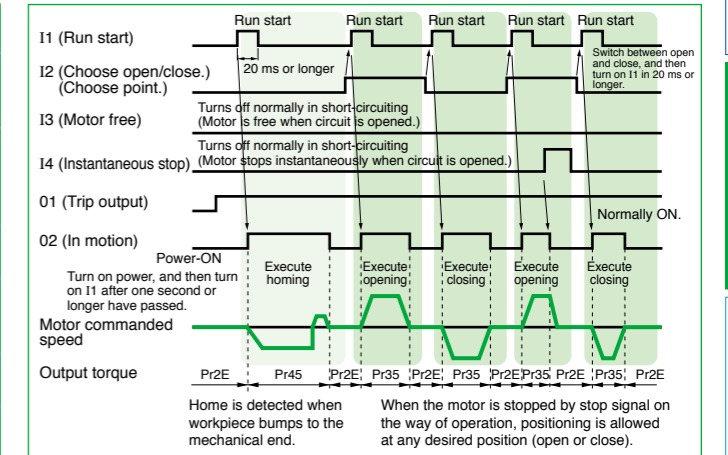

[Parameter setting] Indicates only the point changed from default setting. (Parameter marked with * is effective after power resetting.)

Function	Parameter No. (Pr□□)	Name of parameter	Setting	Remarks	
Selection of signal function	50*	I1 function selection	8	Run start	
	51*	I2 function selection	6	Point designation 1 input (choosing the 1st/2nd point)	
	52*	I3 function selection	15	Motor-free input	
	53*	I4 function selection	1	Instantaneous stop input	
	56*	I3 input logic selection	1	Changes the polarity of I3 to effective when open (motor-free in this case).	
	57*	I4 input logic selection	1	Changes the polarity of I4 to effective when open (instantaneous stop in this case).	
	5C	O1 function selection	0	Trip output	
	5d	O2 function selection	2	In-motion signal	
	Homing function	40	Homing mode	3	Bumping homing
		41	Homing direction	1	Set the homing direction normally to minus direction (closing direction).
42		Homing speed	200	Set any desired operation speed.	
44		Homing acceleration/deceleration time	200	Set any desired acceleration/deceleration time.	
45		Bumping torque detection value	50	Torque limit during bumping homing	
46		Bumping torque detection time	100	Home is detected when torque restriction continues for one second.	
47		Home offset	-144	Set the distance from the home desired to be set to the mechanical end.	
48*		Homing function	2	When power is turned on, homing operation is executed by initial I1 input.	
49		Homing selection when motor is free	0	Homing is not required when tripping occurs.	
4A		Present position overflow permission	0	Overflow is not permitted because absolute travel is set.	
The 1st point (door closing position)	23*	Coordinate system setting	0, 1	Set so that homing is in minus direction.	
	00	The 1st target position (rotation number)	0	Set the door closing position coordinate. (Coordinate is 0 when closing position is the same as home position.)	
	01	The 1st target position (pulse)	0		
	02	The 1st coordinate setting	1	Set absolute travel.	
	03	The 1st setting speed	2000	Set any desired operation speed.	
	04, 05	The 1st acceleration time/ The 1st deceleration time	200	Set any desired acceleration time and deceleration time.	
	06	The 1st block setting	0	Set normal operation.	
	The 2nd point (door opening position)	08	The 2nd target position (rotation number)	40	Set the door opening position coordinate.
		09	The 2nd target position (pulse)	0	
		0A	The 2nd coordinate setting	1	Set absolute travel.
0b		The 2nd setting speed	2000	Set any desired operation speed.	
0C, 0d		The 2nd acceleration time/ The 2nd deceleration time	200	Set any desired acceleration time and deceleration time.	
0E		The 2nd block setting	0	Set normal operation.	

For automatically changing the retention torque (retention force) when door is stopped

Gain switching function	Parameter No.	Name of parameter	Setting	Remarks
Gain switching function	2E	Torque limit setting	100	Sets the retention torque when door is stopped. The smaller the value is, the weaker the retention force becomes.
	35	The 2nd torque limit setting	150	Maximum output torque when door is operating.
	36	Gain switching mode selection	2	Set to 0 when executing no switching.
	37	Gain switching time	100	Torque is changed in 100 ms after completion of operation instruction.

Specification (For Common specification, see p. 47, p. 48)

Size	Model No. / Amplifier and Motor		Rated output (W)	Input power supply for Amplifier			Rated torque (N·m)	Starting torque (N·m)	Rated speed (r/min)	Maximum rotation speed (r/min)	
	Brushless Amplifier Model number in () is shipped with power connection cable	Motor		Voltage AC (V)	Allowed range (%)	Frequency (Hz)					Rated input current (A)
80 mm sq.	MBEG5A1BCP (MBEG5A1BCPC)	MBMU5AZAB	50	Single phase 100 to 120	±10	50/60	1.5	0.16	0.24	3000	4000
	MBEG5A5BCP (MBEG5A5BCPC)			Single phase / 3-phase 200 to 240							

* Starting torque: Representative value

Permissible torque at output shaft of gear head (N·m)

Applicable Gear head	Reduction ratio	Permissible torque (N·m)						
		5	10	15	20	30	50	
MB8G□BV	motor rotation speed (r/min) 3000 or less	0.71	1.4	2.2	2.8	4.0	6.8	
	3000 to 4000	0.53	1.1	1.7	2.1	3.0	5.1	
Rotational direction		Same as motor rotational direction				Reverse to motor rotational direction		

Permissible load inertia moment (×10⁻⁴ kg·m²)

Reduction ratio	5	10	15	20	30	50
Applicable Gear head						
MB8G□BV	3.42	13.8	30.6	55.8	127	342

Permissible shaft load

Applicable Gear head	Overhung load (W)	Thrust load (F)
MB8G5BV	245 N	98 N
MB8G10BV, 15BV, 20BV	343 N	
MB8G30BV, 50BV	539 N	

Wiring diagram

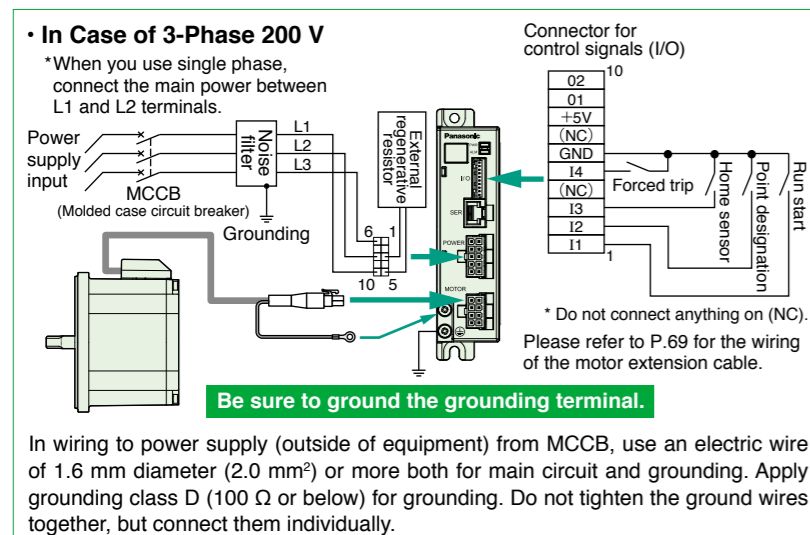

* Please refer to P.95 Support option.

* Before using, be sure to read "Instruction manual" to check precautions and correct procedure.

Motor (dimensions)

Unit mm

mass
0.7 kg

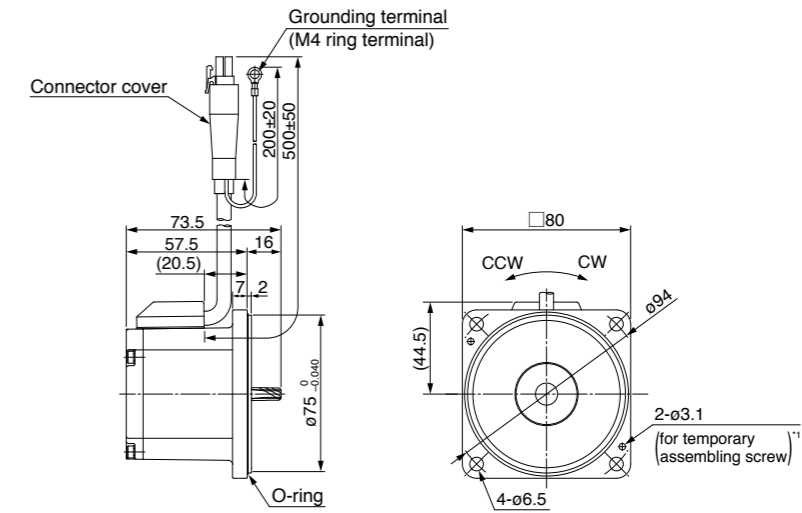

*1 Before installing the equipment, assemble the motor and gear head temporarily, which will ensure stable installation of the equipment.

Gear head (dimensions)

Unit mm

mass
0.8 kg
(0.9 kg)*2

MB8G□BV

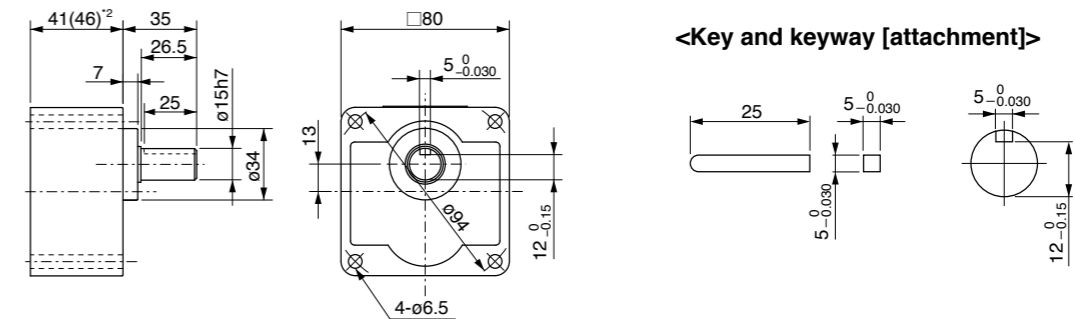

*2 Dimensions and mass with () is the gearhead of gear ratio greater than 30.

Brushless amplifier (dimensions)

Unit mm

mass
0.37 kg

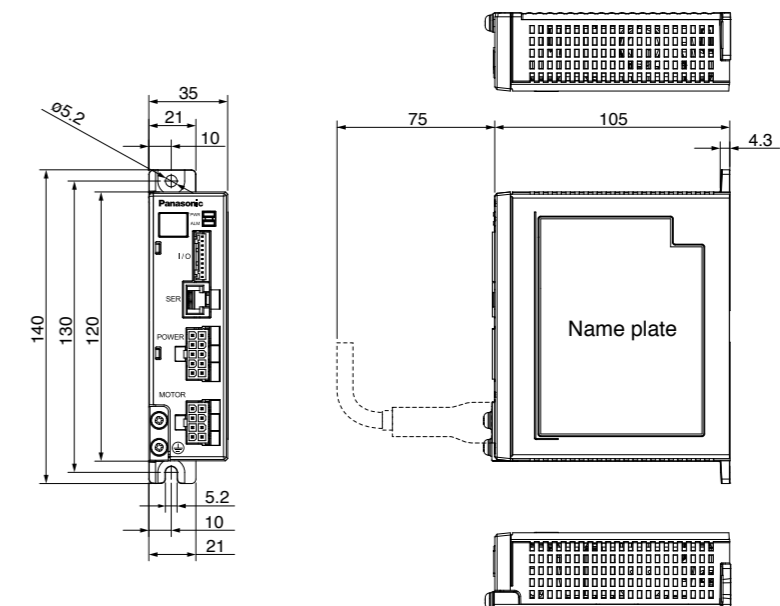

<Cautions> Dimensions are subject to change without notice. Contact us or a dealer for the latest information.

Specification (For Common specification, see p. 47, p. 48)

Size	Model No. / Amplifier and Motor		Rated output (W)	Input power supply for Amplifier			Rated torque (N·m)	Starting torque (N·m)	Rated speed (r/min)	Maximum rotation speed (r/min)
	Brushless Amplifier Model number in () is shipped with power connection cable	Motor		Voltage AC (V)	Allowed range (%)	Frequency (Hz)				
90 mm sq.	MBEG9A1BCP (MBEG9A1BCPC)	MBMU9A1AB	90	Single phase 100 to 120	±10	50/60	0.29	0.43	3000	4000
	MBEG9A5BCP (MBEG9A5BCPC)	MBMU9A2AB		Single phase 200 to 240						

* Starting torque: Representative value

Permissible torque at output shaft of gear head (N·m)

Applicable Gear head	Reduction ratio	Permissible torque (N·m)						
		5	10	15	20	30	50	
MB9G□BV	motor rotation speed (r/min)	3000 or less	1.2	2.5	3.6	4.9	7.0	11.6
	3000 to 4000	0.90	1.9	2.7	3.7	5.3	8.7	
Rotational direction		Same as motor rotational direction				Reverse to motor rotational direction		

Permissible load inertia moment (×10⁻⁴ kg·m²)

Reduction ratio	5	10	15	20	30	50
Applicable Gear head						
MB9G□BV	16.4	67.6	142	257	589	1684

Permissible shaft load

Applicable Gear head	Overhung load (W)	Thrust load (F)
MB9G5BV	294 N	147 N
MB9G10BV, 15BV, 20BV	490 N	
MB9G30BV, 50BV	637 N	

Wiring diagram

In Case of 3-Phase 200 V
*When you use single phase, connect the main power between L1 and L2 terminals.

Connector for control signals (I/O)

02	10
01	
+5V	
(NC)	
GND	
14	
(NC)	
13	
12	
11	

* Do not connect anything on (NC). Please refer to P.69 for the wiring of the motor extension cable.

Be sure to ground the grounding terminal.

In wiring to power supply (outside of equipment) from MCCB, use an electric wire of 1.6 mm diameter (2.0 mm²) or more both for main circuit and grounding. Apply grounding class D (100 Ω or below) for grounding. Do not tighten the ground wires together, but connect them individually.

* Please refer to P.95 Support option.

* Before using, be sure to read "Instruction manual" to check precautions and correct procedure.

Motor (dimensions)

Unit mm

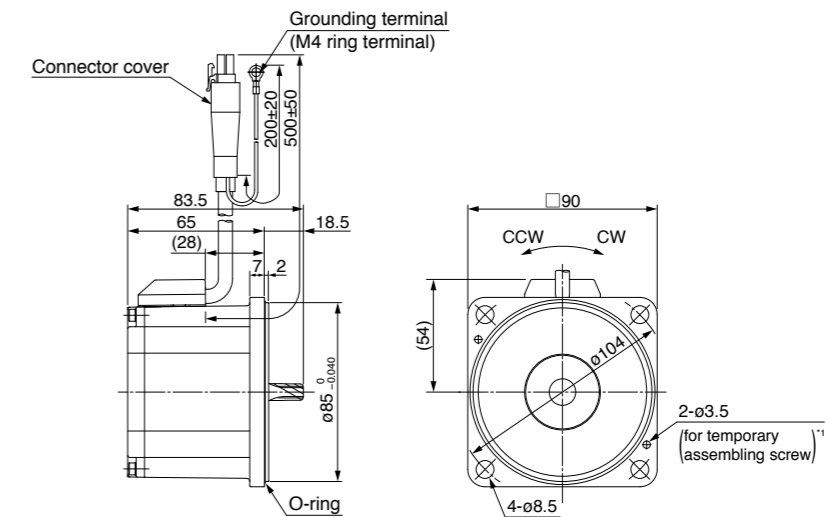

mass
1.0 kg

*1 Before installing the equipment, assemble the motor and gear head temporarily, which will ensure stable installation of the equipment.

Gear head (dimensions)

Unit mm

MB9G□BV

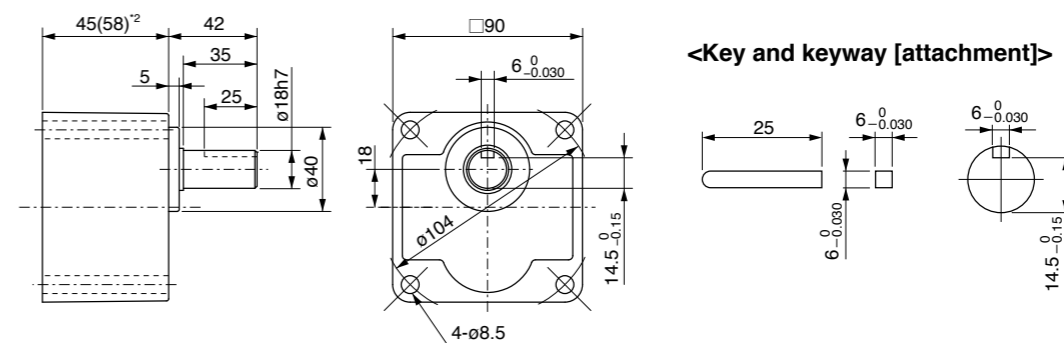

mass
1.1 kg
(1.4 kg)^{*2}

*2 Dimensions and mass with () is the gearhead of gear ratio greater than 30.

Brushless amplifier (dimensions)

Unit mm

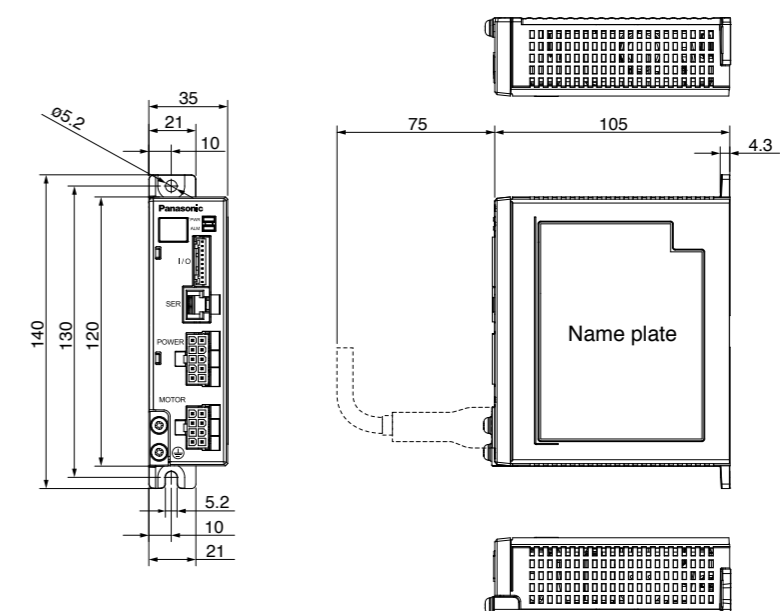

mass
0.37 kg

<Cautions> Dimensions are subject to change without notice. Contact us or a dealer for the latest information.

Specification (For Common specification, see p. 47, p. 48)

Size	Model No. / Amplifier and Motor		Rated output (W)	Input power supply for Amplifier			Rated torque (N·m)	Starting torque (N·m)	Rated speed (r/min)	Maximum rotation speed (r/min)
	Brushless Amplifier Model number in () is shipped with power connection cable	Motor		Voltage AC (V)	Allowed range (%)	Frequency (Hz)				
90 mm sq.	MBEG1E1BCP (MBEG1E1BCPC)	MBMU1E1AB	130	Single phase 100 to 120	±10	50/60	0.41	0.62	3000	4000
	MBEG1E5BCP (MBEG1E5BCPC)	MBMU1E2AB		Single phase 200 to 240						

* Starting torque: Representative value

Permissible torque at output shaft of gear head (N·m)

Applicable Gear head	Reduction ratio	Permissible torque (N·m)						
		5	10	15	20	30	50	
MB9G□BV	motor rotation speed (r/min)	3000 or less	1.9	3.7	5.6	7.4	10.7	17.7
		3000 to 4000	1.1	2.1	3.3	4.3	6.2	10.3
	Rotational direction	200 V	1.4	2.8	4.2	5.6	8.0	13.3
		Same as motor rotational direction					Reverse to motor rotational direction	

Permissible load inertia moment (×10⁻⁴ kg·m²)

Reduction ratio	5	10	15	20	30	50
Applicable Gear head						
MB9G□BV	16.4	67.6	142	257	589	1684

Permissible shaft load

Applicable Gear head	Overhung load (W)	Thrust load (F)
MB9G5BV	294 N	147 N
MB9G10BV, 15BV, 20BV	490 N	
MB9G30BV, 50BV	637 N	

Wiring diagram

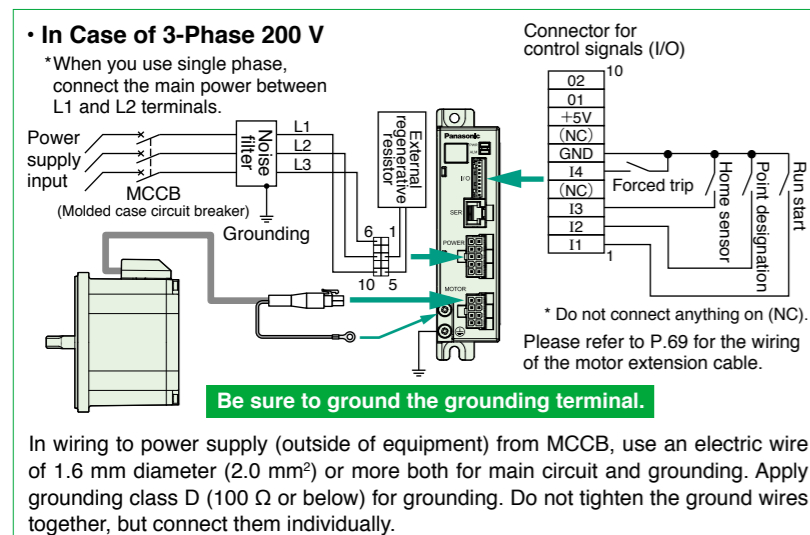

* Please refer to P.95 Support option.

* Before using, be sure to read "Instruction manual" to check precautions and correct procedure.

Motor (dimensions)

Unit mm

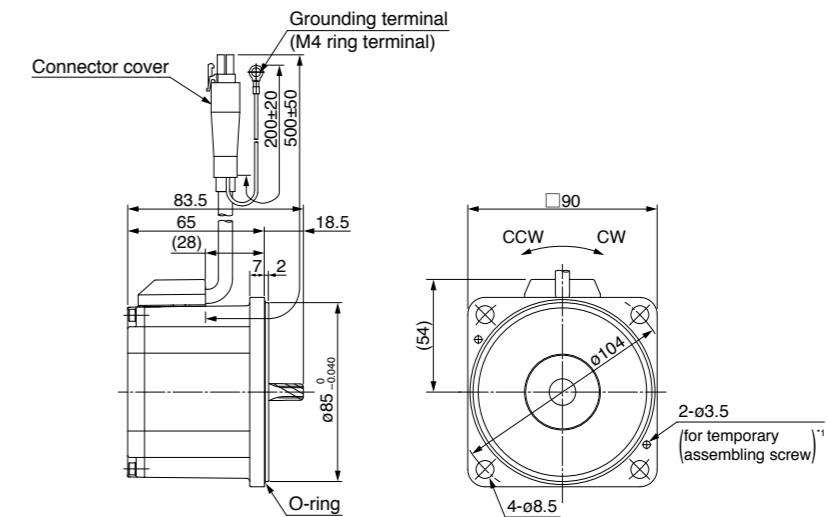

*1 Before installing the equipment, assemble the motor and gear head temporarily, which will ensure stable installation of the equipment.

Gear head (dimensions)

Unit mm

MB9G□BV

mass **1.1 kg (1.4 kg)*2**

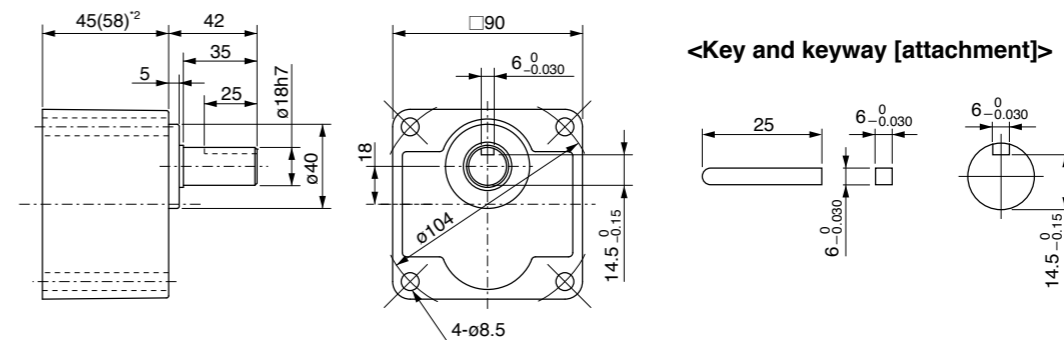

*2 Dimensions and mass with () is the gearhead of gear ratio greater than 30.

Brushless amplifier (dimensions)

Unit mm

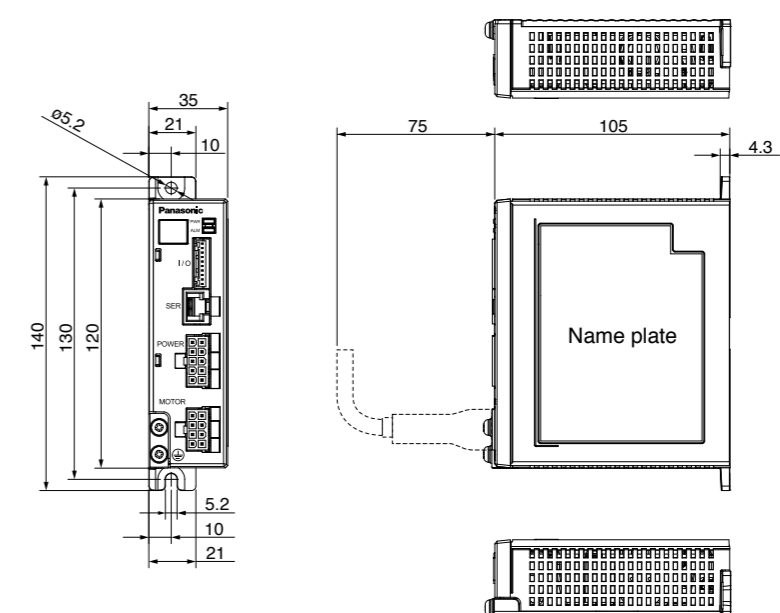

<Cautions> Dimensions are subject to change without notice. Contact us or a dealer for the latest information.

Gear head GP series

Outline of gear head

Reduction ratio

- Reduction ratio are 6 types 1/5 to 1/50.

Gear type/size

MB8 : 50 W (Hinge not attached)

MB9 : 90 W, 130 W (Hinge not attached)

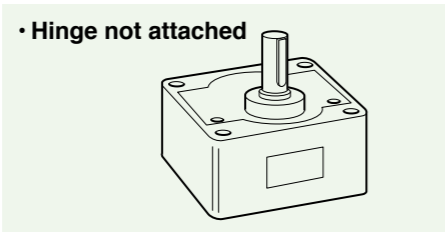

Backlash

Less than 2° (design value)

Type of gear head and reduction ratio

Gear type/size	Motor capacity	Reduction ratio					
		1/5	1/10	1/15	1/20	1/30	1/50
MB8	50 W	○	○	○	○	○	○
MB9	90 W, 130 W	○	○	○	○	○	○

Check the Model number

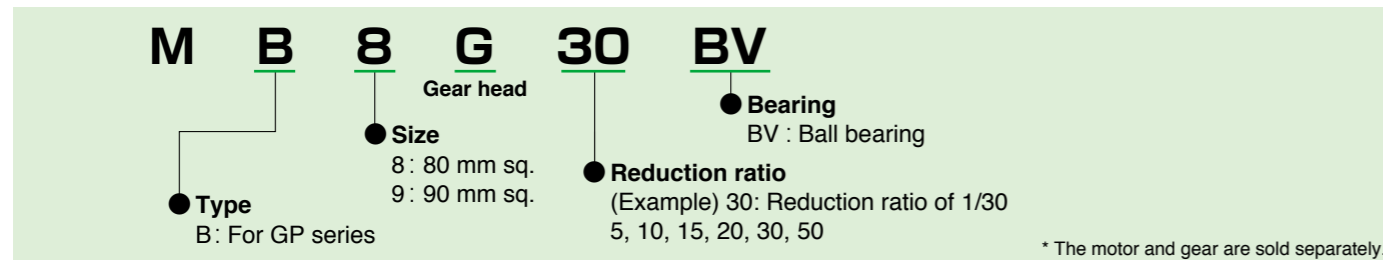

Calculation of torque at output shaft of gear head

Standard gear head only

$$N_G = \frac{N_M}{i}$$

N_G : Speed of gear head [r/min] T_G : Output torque of gear head [N·m]

$$T_G = T_M \times i \times \eta$$

N_M : Motor speed [r/min] T_M : Motor torque [N·m]

i : Reduction ratio of gear head η : Gear head efficiency

Maximum permissible torque

There is a limit to the strength of a gear due to its material and construction. The usable load torque determined based on this limit is called permissible torque. As can be seen from the above-mentioned formula, the load becomes larger when the reduction ratio is increased. If the gear head is used with the load exceeding the permissible torque, its life expectancy will be shortened significantly. Refer to the permissible torque for each model and use the gear head at an appropriate load.

Nominal reduction ratio and actual reduction ratio

Actual reduction ratio of MB8, MB9 is the same as the nominal reduction ratio.

The numbers in the following table represents the denominator of actual reduction ratio.

Gear type		Nominal reduction ratio					
		1/5	1/10	1/15	1/20	1/30	1/50
Actual reduction ratio	MB8G□BV	5	10	15	20	30	50
	MB9G□BV	5	10	15	20	30	50

Gear head efficiency

Gear type		Reduction ratio					
		1/5	1/10	1/15	1/20	1/30	1/50
	MB8G□BV	90 %			86 %		
	MB9G□BV	90 %			86 %		

Gear head efficiency and ambient temperature

Calculate the actual gear head efficiency by multiplying the above-shown gear head efficiency at room temperature by the torque reduction ratio shown below.

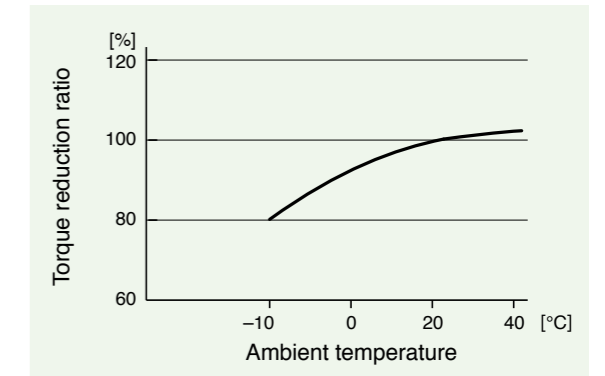

Standard life

Standard life is 10000 hours for the motor equipped with gear head (MB8G and MB9G).

(Standard life of sealing performance of oil seal is 5000 hours.)

Standard life refers to design life for operation 8 hours per day (service factor: Sf = 1.0) at a normal temperature and humidity, under uniform load (permissible shaft torque of gear head and rated torque of motor).

* Standard life in the case of 3000 r/min to 4000 r/min rotation speed of the motor, please calculated by the following formula.

$$\text{Standard life (hours)} = 10000 \text{ (h)} \times 3000 \text{ (r/min)} / \text{rotation speed (r/min)}$$

<Information>

Repeated forward/reverse operation with motor shaft rotation angle below 45 degrees causes fretting of bearing (partial wear due to bearing out of grease), and is not advisable. It does not apply if operation is available to rotate the motor shaft above 45 degrees at an appropriate interval more than once a day.)

Oscillation due to inappropriate setting of gain, also causes fretting.

Note that gear head shaft is also subject to this restriction.

Service factor (Sf)

$$\text{Life expectancy} = \frac{\text{Standard life}}{\text{Service factor (Sf)}}$$

Service factor (Sf) varies with impact of load and operation time. The table below shows how the service factor value depends on load condition.

Type of load	Typical load	Service factor		
		5 hours/day	8 hours/day	24 hours/day
Constant	Belt conveyor, One-directional rotation	1.0	1.0	1.5
Light-impact	Start/Stop, Cam-drive	1.2	1.5	2.0
Medium-impact	Instant FWD/REV, Instant stop	1.5	2.0	2.5
Heavy-impact	Frequent medium-impact	2.5	3.0	3.5

<Important>

The gear heads MB8G□BV and MB9G□BV are designed for use with GP series, and MX8G□B, MZ9G□B and MY9G□B are designed for use with GV series, respectively, and they are not compatible with gear heads of different series.

Gear head GP series

Model list of gear head

Gear head

Ball bearing

Size	Reduction ratio	Model No.
80 mm sq. (50 W)	1/5, 1/10, 1/15	MB8G5BV、 MB8G10BV、 MB8G15BV
	1/20, 1/30	MB8G20BV、 MB8G30BV
	1/50	MB8G50BV
90 mm sq. (90 W・130 W) Common use	1/5	MB9G5BV
	1/10, 1/15	MB9G10BV、 MB9G15BV
	1/20, 1/30, 1/50	MB9G20BV、 MB9G30BV、 MB9G50BV

* For the specifications for each item, refer to the page of the motor to which it can be applied.

Gear head accessory

Ball bearing

Size	Reduction ratio	Model No.	Accessory				
			Screw (mm)	Flat washer	Hexagon nut	For temporary assembling screw hexagon socket head bolt	Key
80 mm sq.	1/5 to 1/20	MB8G5BV to MB8G20BV	M6×65 hexagon socket head bolt : 4	for M6: 4	M6: 4	M2.6×12 : 2	5×5×25 one-end round : 1
	1/30, 1/50	MB8G30BV、 MB8G50BV	M6×70 hexagon socket head bolt : 4	for M6: 4	M6: 4	M2.6×12 : 2	5×5×25 one-end round : 1
90 mm sq.	1/5 to 1/20	MB9G5BV to MB9G20BV	M8×75 hexagon socket head bolt : 4	for M8: 4	M8: 4	M3×12 : 2	6×6×25 one-end round : 1
	1/30, 1/50	MB9G30BV、 MB9G50BV	M8×90 hexagon socket head bolt : 4	for M8: 4	M8: 4	M3×12 : 2	6×6×25 one-end round : 1

O-ring

Repair parts 10pcs / bag

Size	Part No.
80 mm sq.	DV0PN10008
90 mm sq.	DV0PN10009

<Information>

MB type gear head is provided with temporary assembling screw (two hexagon socket head bolt). Before installing the equipment, assemble the motor and gear head temporarily, which will ensure stable installation of the equipment. In installing to the equipment, be sure to use four "mounting screws" attached to the gear head for secure installation.

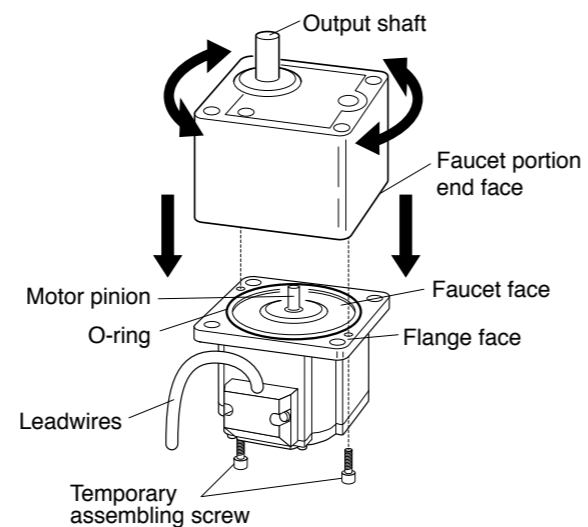
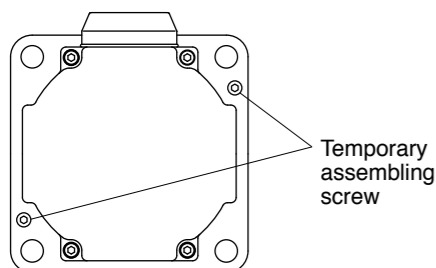

- Assemble with motor pinion faced up.
- Outward direction of motor leadwire can be aligned with any one of 4 sides of gear head with an output shaft at a different position.

Options



Contents	
Options – Details	67
List of peripheral equipments	75

Option

Noise filter/ Surge absorber/ MCCB

Part name	Optional parts number (option)	Manufacturer's parts number	Qty.	Manufacturer
Noise filter (single phase 100 V, 200 V)	DV0P4170	SUP-EK5-ER-6	1	OKAYA ELECTRIC IND. CO., LTD.
Noise filter (3-phase)	DV0PM20042	3SUP-HU10-ER-6	1	
Surge absorber (single phase 100 V, 200 V)	DV0P4190	R·A·V-781BWZ-4	1	
Surge absorber (3-phase)	DV0P1450	R·A·V-781BXZ-4	1	TDK Corporation
Noise filter for control signals	DV0P1460	ZCAT3035-1330	4	

Noise filter GV KV GP

• DV0P4170

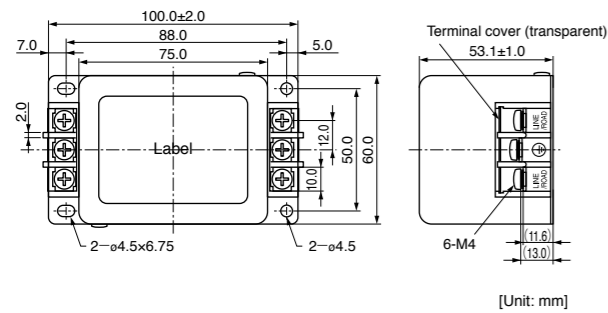

• DV0PM20042

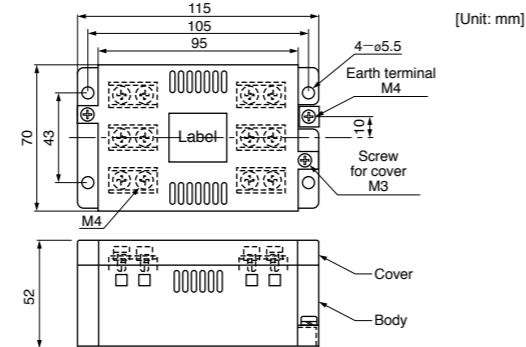

Surge absorber GV KV GP

• DV0P4190

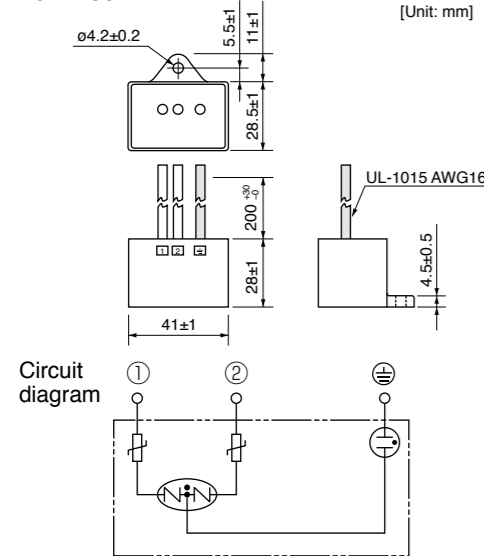

• DV0P1450

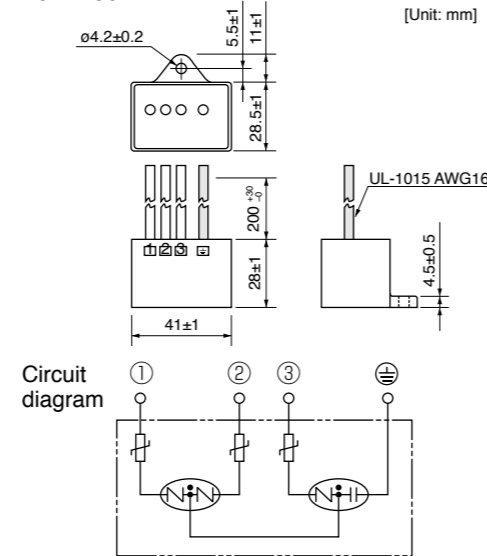

Noise filter for control signals GV KV GP

• DV0P1460

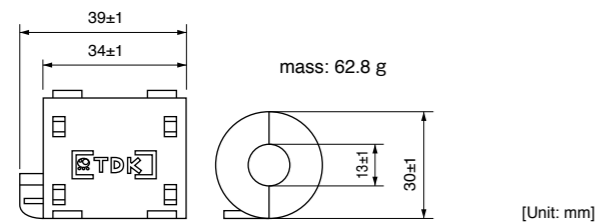

Recommended circuit breaker (MCCB)

Made by Sensata Technologies Japan Limited: Type IELH-1-11-63-5A-M (single phase) Type IELH-1-111-63-5A-M (3-phase)
 (Rated current 5A, cutoff characteristics DELAY63)
 • Recommended cutoff characteristics: DELAY61-63

Settings

Console A GV KV

Optional part number
DV0P3500

- Speed adjusting knob
- RUN/STOP switch
- Rotation direction selector switch

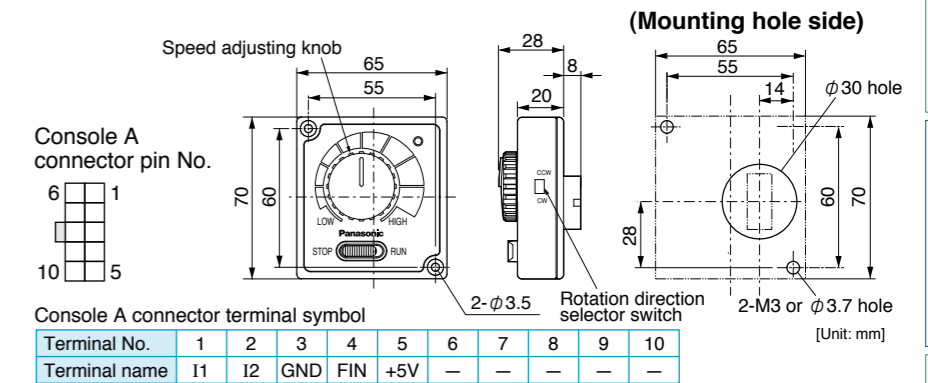

Digital key pad GV KV GP

Optional part number
DV0P3510

- RUN/STOP key
- Digital monitor [Rotation speed, Commanded speed, Internal DC voltage, Load factor, Torque, Trip history, (Display of the trip occurs, confirmation of the trip history) Overload warning (flashing)]
- Set/change parameters
- Storage of the parameters (read, write)

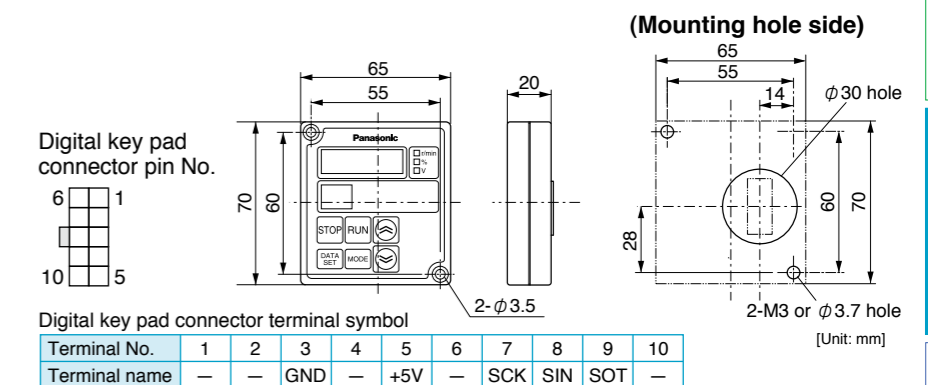

Cable

Console A connection cable GV KV

Optional parts number	Length (L)
DV0PM2006910	1 m
DV0PM2006930	3 m
DV0PM2006950	5 m

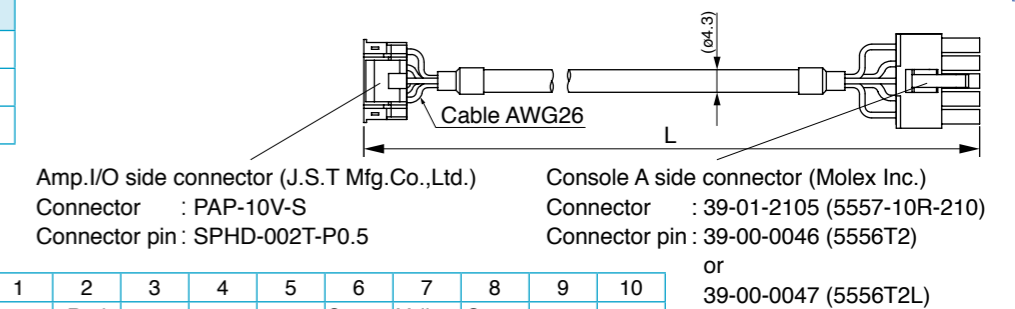

Amp.I/O side connector pin No.	1	2	3	4	5	6	7	8	9	10
Lead color of a cable	Brown	Red				Orange	Yellow	Green		
Console A side connector pin No.	1	2	-	-	-	3	4	5	-	-

Digital key pad connection cable GV KV GP

Optional parts number	Length (L)
DV0P38310	1 m
DV0P38330	3 m
DV0P38350	5 m

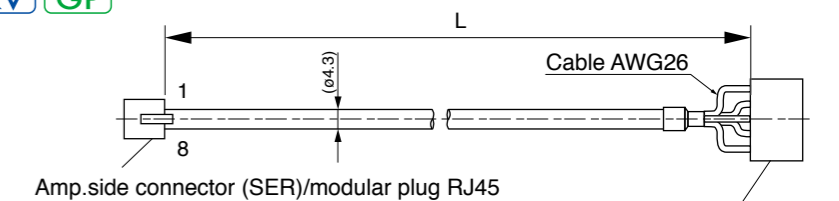

Amp.side connector pin No.(SER)	1	2	3	4	5	6	7	8
Terminal name	-	+5V	SOT	SIN	-	-	GND	SCK
Digital key pad side connector pin No.	-	5	9	8	-	-	3	7

Option

Motor extension cable GV GP

Optional parts number	Length (L)
DV0PQ1000110	1 m
DV0PQ1000130	3 m
DV0PQ1000150	5 m
DV0PQ10001A1	10 m

Accessories

- Insulating cap (for grounding wire insulation) 1
- M4 x 6 pan head screw with spring washer 1
- M4 hex. nut 1

Insulating cap (for grounding wire insulation)

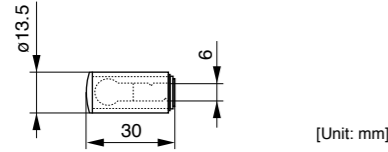

[Unit: mm]

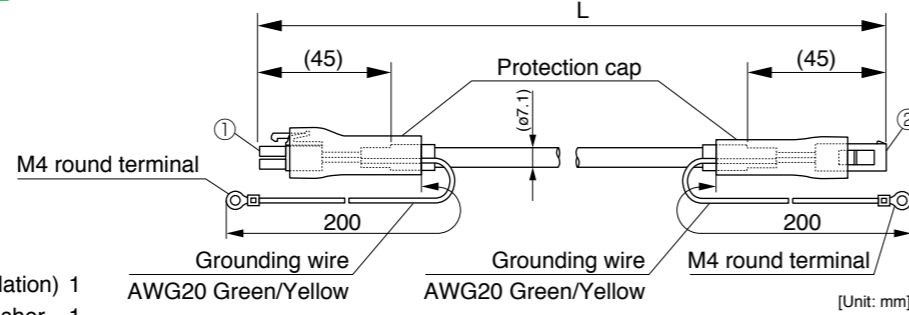

- ① Brushless amplifier side connector (Molex Inc.)
 Connector : 39-01-2085 (5557-08R-210)
 Connector pin : 39-00-0039 (5556TL) [for AWG 20]
 39-00-0047 (5556T2L) [for AWG 26]
- ② Motor side connector (Molex Inc.)
 Connector : 39-01-2086 (5559-08P-210)
 Connector pin : 39-00-0041 (5558TL) [for AWG 20]
 39-00-0049 (5558T2L) [for AWG 26]

[Unit: mm]

- When using motor extension cable, be sure to connect its grounding wire to the grounding wire of the motor, and connect the other end of grounding wire of the extension cable to the earth terminal of the brushless amplifier.
- For connecting grounding wire of motor and motor extension cable, use M4 screw and insulating cap supplied as accessories.

<Connector wiring>

• Brushless amplifier side				• Motor side	
Pin No.	Signal	Wire color	Wire size	Pin No.	
1	U	Red	AWG20	1	
2	V	White	AWG20	2	
3	W	Black	AWG20	3	
4	Vcc	White	AWG26	4	
5	CS1	Red	AWG26	5	
6	CS2	Blue	AWG26	6	
7	CS3	Yellow	AWG26	7	
8	0V	Black	AWG26	8	
M4 round terminal	E	Green/Yellow	AWG20	M4 round terminal	

Motor extension cable KV

Optional parts number	Length (L)
DV0PQ1000310	1 m
DV0PQ1000330	3 m
DV0PQ1000350	5 m
DV0PQ10003A1	10 m

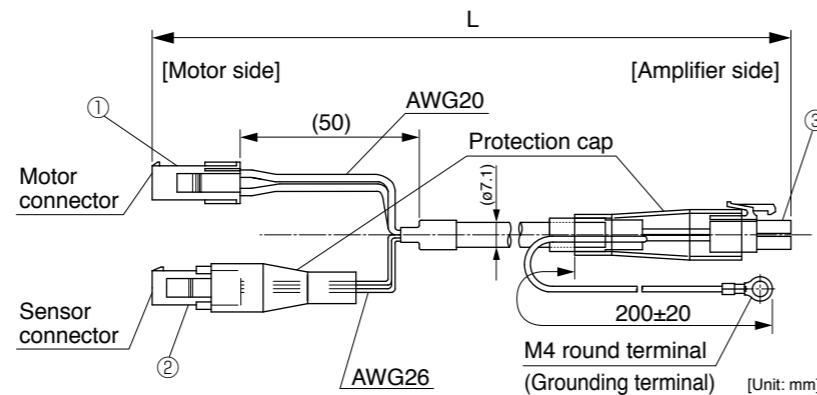

<Wiring of motor side connector>

• Motor connector

Pin No.	Signal	Wire color
1	U	Red
2	V	White
3	W	Black
4	E	Green/Yellow

• Sensor connector

Pin No.	Signal	Wire color
1	CS1	Red
2	CS2	Blue
3	CS3	Yellow
4	Vcc	White
5	0V	Black
6	NC	—

Do not connect anything on (NC).

- ① Motor side motor connector (Tyco Electronics.)
 Connector : 172159-1
 Connector pin : 170366-1 [for AWG 20]
- ② Motor side sensor connector (Molex Inc.)
 Connector : 39-01-2066 (5559-06P-210)
 Connector pin : 39-00-0049 (5558T2L) [for AWG 26]
- ③ Brushless amplifier side connector (Molex Inc.)
 Connector : 39-01-2085 (5557-08R-210)
 Connector pin : 39-00-0039 (5556TL) [for AWG 20]
 39-00-0047 (5556T2L) [for AWG 26]

<Connector wiring of amplifier side>

Pin No.	Signal	Wire color	Wire size
1	U	Red	AWG20
2	V	White	AWG20
3	W	Black	AWG20
4	Vcc	White	AWG26
5	CS1	Red	AWG26
6	CS2	Blue	AWG26
7	CS3	Yellow	AWG26
8	0V	Black	AWG26
M4 round terminal	E	Green/Yellow	AWG20

PC connection cable (10-pin D-sub connector pin 1.5 m) GV KV GP

Optional parts number	Length (L)
DV0P4140	1.5 m

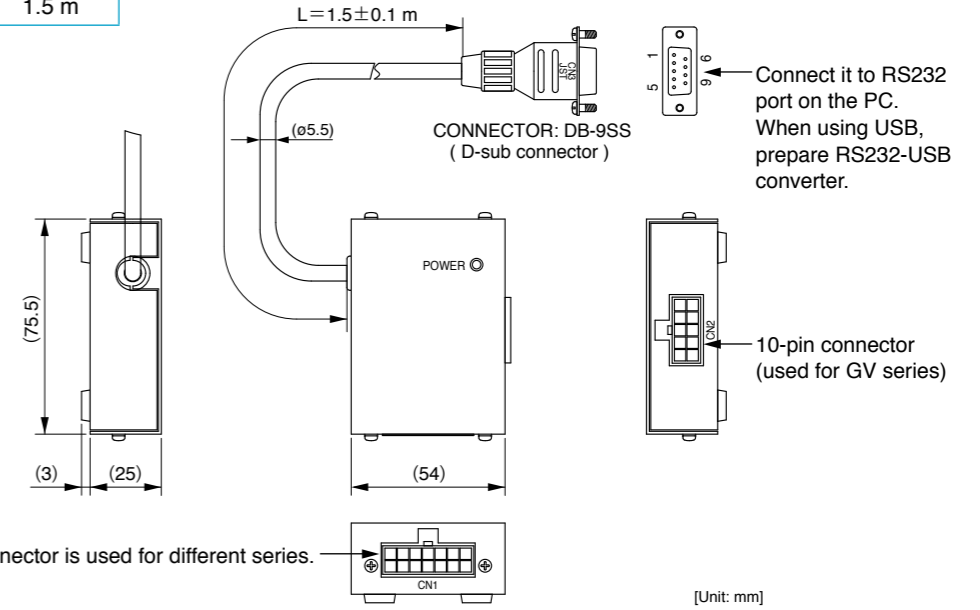

This 14-pin connector is used for different series.

[Unit: mm]

Communication software GV KV GP

Model No.	
PANATERM for BL	Can be downloaded from our web site, free of charge. http://industrial.panasonic.com/ww/products/motors-compressors/fa-motors

Connector Kit/ Cable/ External speed setter

Power supply connector kit GV KV (50 W, 100 W) GP

Optional part number	Name	Manufacturer's parts No.	Qty.	Manufacturer	Note
DV0P2870	Connector	39-01-2105 (5557-10R-210)	1	Molex Inc	Fits to power supply connector (POWER)
	Connector pin	39-00-0060 (5556PBTTL)	6		

- 39-01-2105 (5557-10R-210)



Control signal cable (Cable with an I/O connector) GV KV GP

Optional parts number	Length (L)
DV0PM20076	2 m

Pin No.	1	2	3	4	5	6	7	8	9	10
Terminal name	GV, KV series I1	I2	I3	I4	I5	GNG	FIN	+5 V	O1	O2
GP series	I1	I2	I3	NC	I4	GND	NC	+5 V	O1	O2
Wire color	Brown	Red	Orange	Yellow	Green	Blue	Purple (Pink)	Gray	White	Black

* Do not connect anything to the pin no.4 and pin no.7 in case of use the GP series.

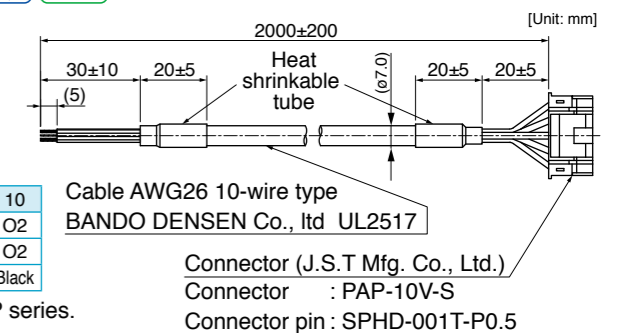

<For your reference>

For tools such as crimp tools necessary to assemble the cable, access the connector manufacturer's web site or consult the manufacturer: refer to p. 75 "List of peripheral equipment manufacturers".

Option

I/O connector kit GV KV GP

Optional part number	Name	Manufacturer's parts No.	Qty.	Manufacturer	Note
DV0PM20070	Connector	PAP-10V-S	1	J.S.T Mfg.Co.,Ltd.	Fits to I/O connector
	Connector pin	SPHD-002T-P0.5	10		

• PAP-10V-S

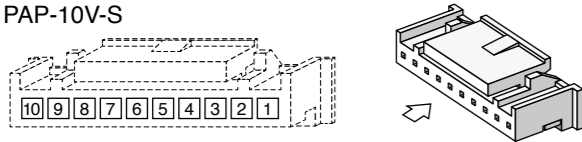

Pin No.	1	2	3	4	5	6	7	8	9	10	
Terminal name	GV, KV series	I1	I2	I3	I4	I5	GNG	FIN	+5 V	O1	O2
	GP series	I1	I2	I3	NC	I4	GND	NC	+5 V	O1	O2

* Do not connect anything to the pin no.4 and pin no.7 in case of use the GP series.

External speed setter GV KV

Optional part number
DV0PM20078

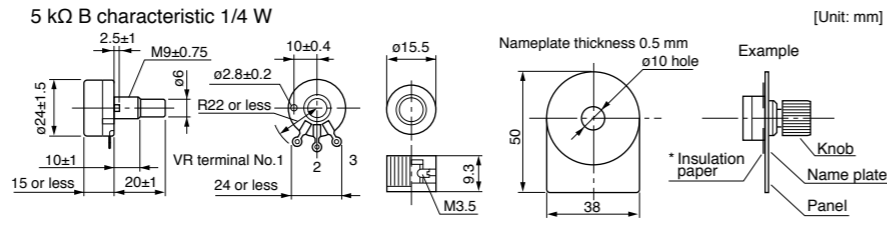

* Insert the insulation paper to positively isolate the terminals and chassis.

Panel connector kit (Fits to Console A) GV KV

Optional part number	Name	Manufacturer's parts No.	Qty.	Manufacturer	Note
DV0P3610	Connector	39-01-2105 (5557-10R-210)	1	Molex Inc	Fits to Console A
	Connector pin	39-00-0047 (5556T2L)	10		

• 39-01-2105 (5557-10R-210)



External regenerative resistor GV KV GP

Optional parts number	Manufacturer's parts number	Specifications			Note (Input Power of drive)	Manufacturer
		Resistance	Rated power	Activation temperature of built-in fuse		
DV0P2890	45M03	50 Ω	10 W	137 \pm 0.0 °C	100 V	Iwaki Musen Kenkyusho Co., Ltd
DV0PM20068	45M03	200 Ω	10 W	137 \pm 0.0 °C	200 V	

• DV0P2890, DV0PM20068

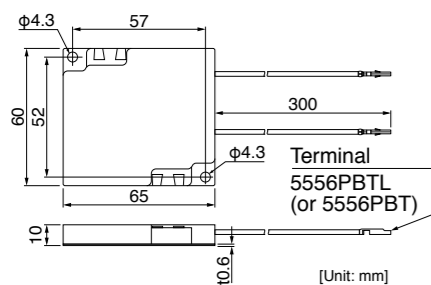

[Unit: mm]

* Connect terminals to pins No. 3 and No. 5 of the power supply connector, respectively.

KV

* When using amplifiers of 50 W or 100 W. Connect terminals to pins No. 3 and No. 5 of the power supply connector, respectively.

When using amplifiers of 200 W, 400 W or 750 W. Connect terminals to pins No.4 (P) and No.5 (B1) of the power supply terminals block with using pin terminals.

<Caution of when using external regeneration resistor>

Since it becomes high temperature, external regeneration resistor must be installed according to the contents shown below.

- Attach to incombustibles, such as metal.
- Install in the place which cannot touch directly by covering with incombustibles etc.
- Do not install near the combustibles.

Although the thermal cutoff is built in external regeneration resistor, the skin temperature of regeneration resistor may become high exceeding the operating temperature of thermal cutoff by the time the thermal cutoff operates in amplifier failure.

The thermal cutoff is for preventing ignition of the regeneration resistor in amplifier failure, and is not for controlling the skin temperature of resistor.

<Remarks>

Thermal fuse is installed for safety.

The thermal fuse may blow due to heat dissipating condition, working temperature, supply voltage or load fluctuation.

Make it sure that the surface temperature of the resistor may not exceed 100 °C at the worst running conditions with the machine, which brings large regeneration (such case as high supply voltage, load inertia is large or deceleration time is short) Please carry out air cooling if needed.

DIN rail mounting unit GV KV (50 W, 100 W) GP

Optional part number
DV0P3811

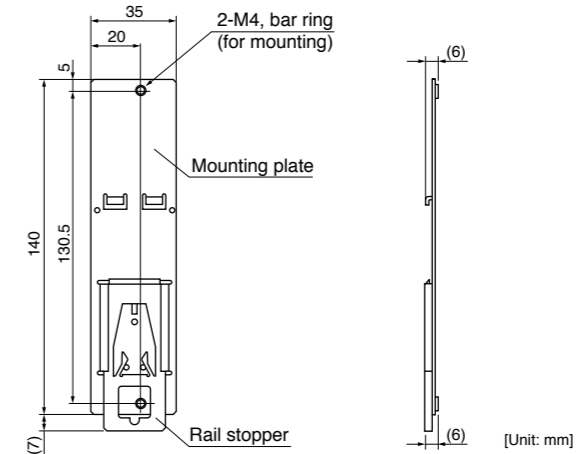

[Unit: mm]

• How to Install

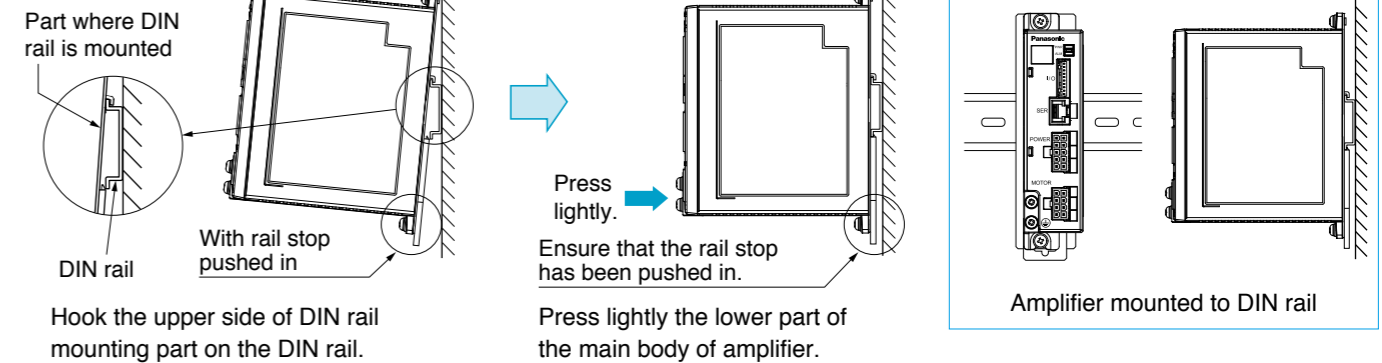

• Removing from DIN Rail

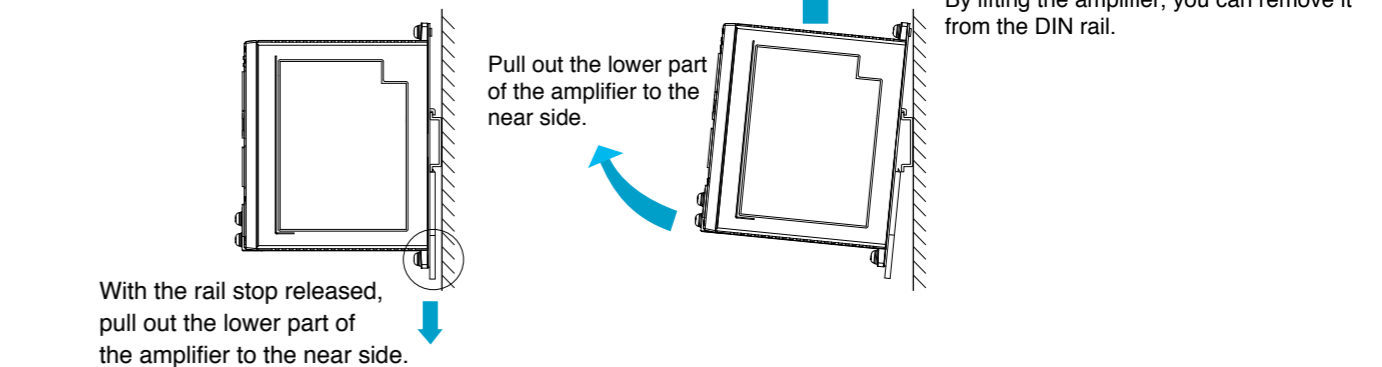

<Notes>

2 mounting screws (M4 X L8, Pan head) are attached.
Rail stopper can be extended to max. 10 mm.

<Cautions>

Please read carefully operation manual before using this product.
In addition, please do not apply excessive stress to the product.

Reactor **GV** **KV** **GP**

Fig.1

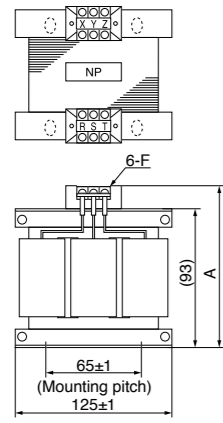

• Wiring of the reactor
<3-Phase 200 V>

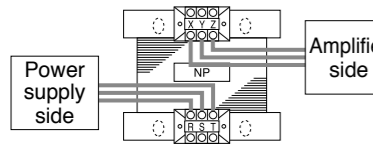
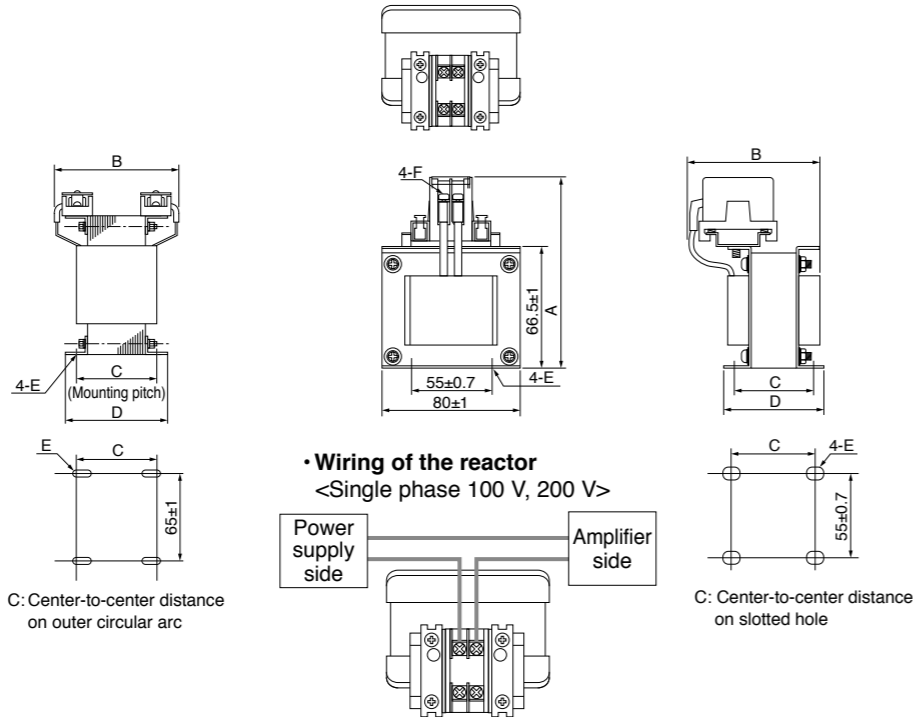
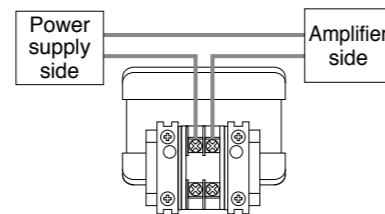

Fig.2



• Wiring of the reactor
<Single phase 100 V, 200 V>



[Unit: mm]

	Optional parts number	A (Max)	B (Max)	C	D	E	F	Inductance (mH)	Rated current (A)
Fig.1	DV0P220	136	155	70 +3/-0	85±2	4-7φ×12	M4	6.81	3
Fig.2	DV0P227	110	90	41±2	55±2	4-5φ×10	M4	4.02	5
	DV0P228	110	95	46±2	60±2	4-5φ×10	M4	2	8

* For applicability of reactor, refer to the corresponding table on p. 95.

Harmonic restraint

Harmonic restraint measures are not common to all countries. Therefore, prepare the measures that meet the requirements of the destination country.

With products for Japan, on September, 1994, "Guidelines for harmonic restraint on heavy consumers who receive power through high voltage system or extra high voltage system" and "Guidelines for harmonic restraint on household electrical appliances and general-purpose articles" established by the Agency for Natural Resources and Energy of the Ministry of Economy, Trade and Industry (the ex-Ministry of International Trade and Industry). According to those guidelines, the Japan Electrical Manufacturers' Association (JEMA) have prepared technical documents (procedure to execute harmonic restraint:

JEM-TR 198, JEM-TR 199 and JEM-TR 201) and have been requesting the users to understand the restraint and to cooperate with us. On January, 2004, it has been decided to exclude the general-purpose inverter and servo driver from the "Guidelines for harmonic restraint on household electrical appliances and general-purpose articles". After that, the "Guidelines for harmonic restraint on household electrical appliances and general-purpose articles" was abolished on September 6, 2004.

We are pleased to inform you that the procedure to execute the harmonic restraint on general-purpose inverter and servo driver was modified as follows.

- All types of the general-purpose inverters and servo drivers used by specific users are under the control of the "Guidelines for harmonic restraint on heavy consumers who receive power through high voltage system or extra high voltage system". The users who are required to apply the guidelines must calculate the equivalent capacity and harmonic current according to the guidelines and must take appropriate countermeasures if the harmonic current exceeds a limit value specified in a contract demand. (Refer to JEM-TR 210 and JEM-TR 225.)
- The "Guidelines for harmonic restraint on household electrical appliances and general-purpose articles" was abolished on September 6, 2004. However, based on conventional guidelines, JEMA applies the technical documents JEM-TR 226 and JEM-TR 227 to any users who do not fit into the "Guidelines for harmonic restraint on heavy consumers who receive power through high voltage system or extra high voltage system" from a perspective on enlightenment on general harmonic restraint. The purpose of these guidelines is the execution of harmonic restraint at every device by a user as usual to the utmost extent.

<Remarks>

When using a reactor, be sure to install one reactor to one brushless amplifier.

O-ring **GV** **GP**

Repair parts 10pcs / bag

Optional parts number	Size
DV0PN10008	80 mm sq.
DV0PN10009	90 mm sq.

- Assemble with motor pinion faced up.
- Outward direction of motor leadwire can be aligned with any one of 4 sides of gear head with an output shaft at a different position.

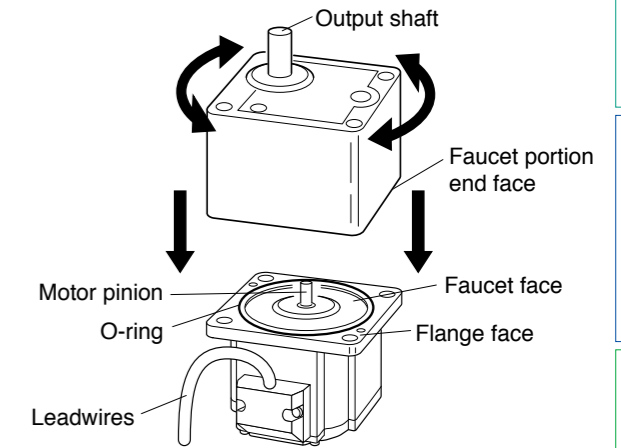

Power cable (single phase 100 V, 200 V) with connector **GV** **KV** (50 W, 100 W) **GP**

When the following part number is specified in the order, the power cable is delivered with the product.

		50 W	90 W	100 W	130 W
GV series	100 V	MBEG5A1BCVC	MBEG9A1BCVC	—	MBEG1E1BCVC
	200 V	MBEG5A5BCVC	MBEG9A5BCVC	—	MBEG1E5BCVC
KV series	100 V	MBEK5A1BCVC	—	MBEK011BCVC	—
	200 V	MBEK5A5BCVC	—	MBEK015BCVC	—
GP series	100 V	MBEG5A1BCPC	MBEG9A1BCPC	—	MBEG1E1BCPC
	200 V	MBEG5A5BCPC	MBEG9A5BCPC	—	MBEG1E5BCPC

- When supplying 3-phase power source to a 200 V brushless amplifier, use the supplied power cable and connect 2 conductors to L1 and L2.
- When supplying 3-phase power, use a power connection kit and connect three conductors to L1, L2 and L3.
- For location of L1, L2 and L3, refer to the wiring diagram on pages 17, 19 and 21 (GV series), pages 35 and 37 (KV series), pages 57, 59 and 61 (GP series).

■ Cable specification

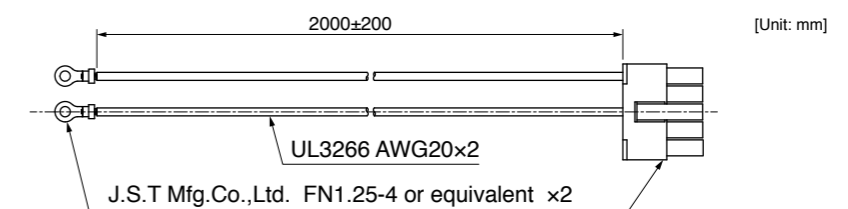

Connector for power supply connection (Molex Inc.)
 Connector : 39-01-2105 (5557-10R-210)
 Connector pin : 39-00-0038 (5556T) or 39-00-0039 (5556T2)

• Grounding wire

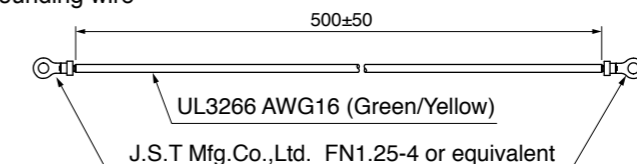

List of peripheral equipments

Manufacturer	Tel No. / Home page	Peripheral components
TDK Corporation	+81-3-5201-7229 http://www.tdk.co.jp/	Noise filter for signal lines
Okaya Electric Industries Co. Ltd.	+81-3-4544-7040 http://www.okayatec.co.jp/	Surge absorber Noise filter
Sensata Technologies Japan Limited	+81-49-283-7575 www.sensata.com/japan	Circuit breaker (MCCB)
Japan Molex Inc.	+81-462-65-2313 http://www.molex.co.jp	Connector
J.S.T. Mfg. Co., Ltd.	+81-45-543-1271 http://www.jst-mfg.com/index_i.html	
Iwaki Musen Kenkyusho Co., Ltd.	+81-44-833-4311 http://www.iwakimusen.co.jp/	Regenerative resistor
KK-CORP.CO.JP	+81-184-53-2307 http://www.kk-corp.co.jp/	Reactor core
NICHIFU Co.,ltd.	+81-6-6911-1455 http://www.nichifu.co.jp/	Pin terminal

* This list is for reference only and subject to change without notice.

MEMO

.....

.....

.....

.....

.....

.....

.....

.....

.....

.....

.....

.....

.....

.....

.....

.....

.....

.....

.....

.....

.....

.....

Information

Information

- CV series
- KV series
- QP series
- Options
- Information

Contents

Guide to the international system of units (SI)77

Selecting motor capacity79

Conformance to international safety standards93

Table of part numbers and options.....95

Index.....97

Sales office101

Guide to the international system of units (SI)

Organization of the system of units

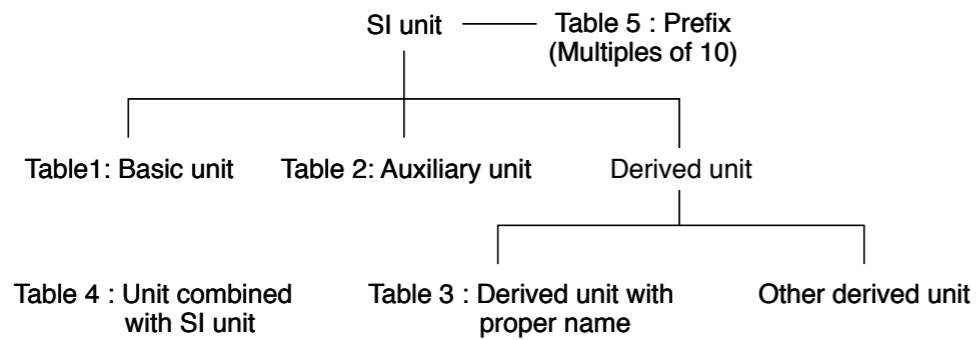

Table 1: Basic unit

Quantity	Name of unit	Symbol of unit
Length	meter	m
Weight	kilogram	kg
Time	second	s
Current	ampere	A
Thermodynamic temperature	kelvin	K
Amount of substance	mol	mol
Luminous intensity	candela	cd

Table 2: Auxiliary unit

Quantity	Name of unit	Symbol of unit
Plane angle	radian	rad
Solid angle	steradian	sr

Table 3: Major derived unit with proper name

Quantity	Name	Symbol of unit	Derivation from basic unit, auxiliary unit or other derived unit
Frequency	hertz	Hz	1 Hz = 1 s ⁻¹
Force	newton	N	1 N = 1 kg·m/s ²
Pressure, Stress	pascal	Pa	1 Pa = 1 N/m ²
Energy, Work, Amount of heat	joule	J	1 J = 1 N·m
Amount of work, Work efficiency, Power, Electric power	watt	W	1 W = 1 J/s
Electric charge, Amount of electricity	coulomb	C	1 C = 1 A·s
Electric potential, Potential difference, Voltage, Electromotive force	volt	V	1 V = 1 J/C
Electrostatic capacity, Capacitance	farad	F	1 F = 1 C/V
Electric resistance	ohm	Ω	1 Ω = 1 V/A
Electric conductance	siemens	S	1 S = 1 Ω ⁻¹
Magnetic flux	weber	Wb	1 Wb = 1 V·s
Magnetic flux density, Magnetic induction	tesla	T	1 T = 1 Wb/m ²
Inductance	henry	H	1 H = 1 Wb/A
Degree centigrade (Celsius)	degree centigrade (Celsius)/ degree	°C	t °C = (t+273.15) K
Luminous flux	lumen	lm	1 lm = 1 cd·sr
Illuminance	lux	lx	1 lx = 1 lm/m ²

Table 4: Unit combined with SI unit

Quantity	Name	Symbol of unit
Time	minute	min
	hour	h
	day	d
Plane angle	degree	°
	minute	'
	second	"
Volume	liter	l, L
Weight	ton	t

Table 5: Prefix

Multiples powered to unit	Prefix	
	Name	Symbol
10 ¹⁸	exa	E
10 ¹⁵	peta	P
10 ¹²	tera	T
10 ⁹	giga	G
10 ⁶	mega	M
10 ³	kilo	k
10 ²	hecto	h
10	deca	da
10 ⁻¹	deci	d
10 ⁻²	centi	c
10 ⁻³	milli	m
10 ⁻⁶	micro	μ
10 ⁻⁹	nano	n
10 ⁻¹²	pico	p
10 ⁻¹⁵	femto	f
10 ⁻¹⁸	atto	a

Major compatible unit

Quantity	Symbol of conventional unit	Symbol of SI unit and compatible unit	Conversion value
Length	μ (micron)	μm	1 μ = 1 μm (micrometer)
Acceleration	Gal	m/s ²	1 Gal = 10 ⁻² m/s ²
	G	m/s ²	1 G = 9.80665 m/s ²
Frequency	c/s, c	Hz	1 c/s = Hz
Revolving speed, Number of revolutions	rpm	s ⁻¹ or min ⁻¹ , r/min	1 rpm = 1 min ⁻¹
Weight	kgf	–	} Same value
Mass	–	kg	
Weight flow rate	kgf/s	–	} Same value
Mass flow rate	–	kg/s	
Specific weight	kgf/m ³	–	} Same value
Density	–	kg/m ³	
Specific volume	m ³ /kgf	m ³ /kg	Same value
Load	kgf	N	1 kgf = 9.80665 N
Force	kgf	N	1 kgf = 9.80665 N
	dyn	N	1 dyn = 10 ⁻⁵ N
Moment of force	kgf·m	N·m	1 kgf·m = 9.806 N·m
Pressure	kgf/cm ²	Pa, bar ⁽¹⁾ or kgf/cm ²	1 kgf/cm ² = 9.80665 x 10 ⁴ Pa = 0.980665 bar
	at (Engineering atmospheric pressure)	Pa	1 at = 9.80665 x 10 ⁴ Pa
	atm (Atmospheric pressure)	Pa	1 atm = 1.01325 x 10 ⁵ Pa
	mHzO, mAq	Pa	1 mHzO = 9.80665 x 10 ³ Pa
	mmHg	Pa or mmHg ⁽²⁾	1 mmHg = 133.322 Pa
	Torr	Pa	
Stress	kgf/mm ²	Pa or N/m ²	1 kgf/mm ² = 9.80665 x 10 ⁶ Pa = 9.80665 x 10 ⁶ N/m ²
	kgf/cm ²	Pa or N/m ²	1 kgf/cm ² = 9.80665 x 10 ⁴ Pa = 9.80665 x 10 ⁴ N/m ²
Elastic modulus	kgf/m ²	Pa or N/m ²	1 kgf/m ² = 9.80665 Pa = 9.80665 N/m ²
			1 kgf/cm ² = 9.80665 x 10 ⁴ N/m ²
Energy, Work	kgf·m	J (joule)	1 kgf·m = 9.80665 J
	erg	J	1 erg = 10 ⁻⁷ J
Work efficiency, Power	kgf·m/s	W (watt)	1 kgf·m/s = 9.80665 W
	PS	W	1 PS = 0.7355 kW
Viscosity	PP	Pa·s	1 P = 0.1 Pa·s
Kinetic viscosity	St	mm ² /s	10 ⁻² St = 1 mm ² /s
Thermodynamic temperature	K	K (kelvin)	1 K = 1 K
	deg	K ⁽³⁾	1 deg = 1 K
Amount of heat	cal	J	1 cal = 4.18605 J
	cal/°C	J/K ⁽³⁾	1 cal/°C = 4.18605 J/K
	Specific heat, Specific heat capacity	cal/ (kgf·°C)	cal/ (kgf·K) ⁽³⁾
Entropy	cal/K	J/K	1 cal/K = 4.18605 J/K
Specific entropy	cal/ (kgf·K)	J/ (kg·K)	1 cal/ (kgf·K) = 4.18605 J/ (kg·K)
Internal energy (Enthalpy)	cal	J	1 cal = 4.18605 J
Specific internal energy (Specific enthalpy)	cal/kgf	J/kg	1 cal/kgf = 4.18605 J/kg
Heat flux	cal/h	W	1 kcal/h = 1.16279 W
Heat flux density	cal/ (h·m ²)	W/m ²	1 kcal/ (h·m ²) = 1.16279 W/m ²
Thermal conductivity	cal/ (h·m·°C)	W/ (m·K) ⁽³⁾	1 kcal/ (h·m·°C) = 1.16279 W/ (m·K)
Coefficient of thermal conductivity	cal/ (h·m ² ·°C)	W/ (m ² ·K) ⁽³⁾	1 kcal/ (h·m ² ·°C) = 1.16279 W/ (m ² ·K)
Intensity of magnetic field	Oe	A/m	1 Oe = 10 ³ / (4π) A/m
Magnetic flux	Mx	Wb (weber)	1 Mx = 10 ⁻⁸ Wb
Magnetic flux density	Gs, G	T (tesla)	1 Gs = 10 ⁻⁴ T

Note

- (1) Applicable to liquid pressure. Also applicable to atmospheric pressure of meteorological data, when "bar" is used in international standard.
- (2) Applicable to scale or indication of blood pressure manometers.
- (3) "C" can be substituted for "K".

Selecting motor capacity

Flow of motor selection

1. Definition of mechanism to be driven by motor.

Define details of individual mechanical components (ball screw length, lead and pulley diameters, etc.)

<Typical mechanism>

Ball screw mechanism

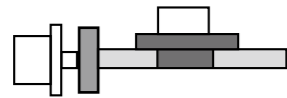

Belt mechanism

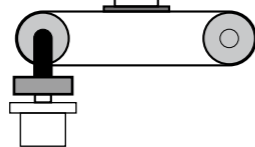

Rack & pinion, etc.

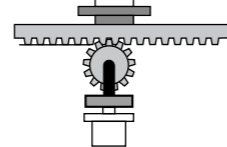

2. Definition of operating pattern.

Acceleration/deceleration time, Constant-velocity time, Stop time, Cycle time, Travel distance

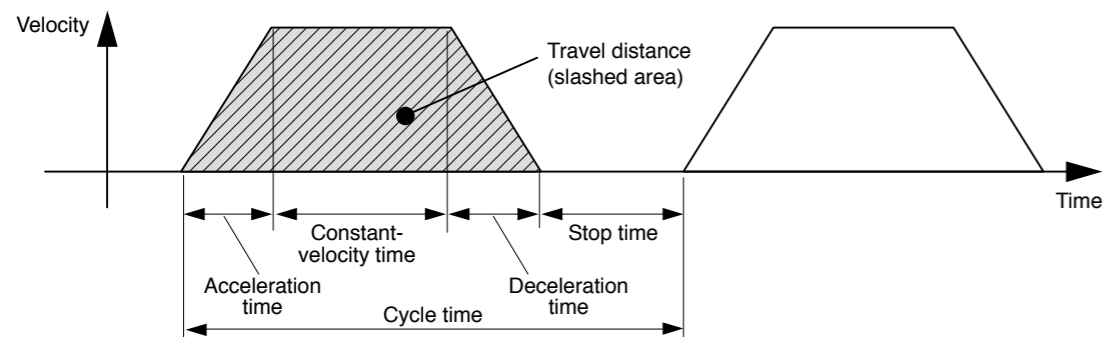

Note) Selection of motor capacity significantly varies depending on the operating pattern.
The motor capacity can be reduced if the acceleration/deceleration time and stop time are set as long as possible.

3. Calculation of load inertia and inertia ratio.

Calculate load inertia for each mechanical component. (Refer to "General inertia calculation method" described later.)

Divide the calculated load inertia by the inertia of the selected motor to check the inertia ratio.

For calculation of the inertia ratio, note that the catalog value of the motor inertia is expressed as "x 10⁻⁴ kg·m²".

4. Calculation of motor velocity

Calculate the motor velocity from the moving distance, acceleration / deceleration time and constant-velocity time.

5. Calculation of torque

Calculate the required motor torque from the load inertia, acceleration/deceleration time and constant-velocity time.

6. Calculation of motor

Select a motor that meets the above 3 to 5 requirements.

Description on the items related to motor selection

1. Torque

(1) Peak torque

Indicate the maximum torque that the motor requires during operation (mainly in acceleration and deceleration steps). The reference value is 80 % or less of the maximum motor torque. If the torque is a negative value, a regenerative discharge resistor may be required.

(2) Traveling torque, Stop holding torque

Indicates the torque that the motor requires for a long time. The reference value is 80 % or less of the rated motor torque. If the torque is a negative value, a regenerative discharge resistor may be required.

Traveling torque calculation formula for each mechanism

Ball screw mechanism

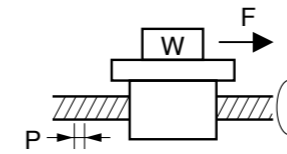

Traveling torque $T_f = \frac{P}{2\pi\eta} (\mu g W + F)$

W : Weight [kg] η : Mechanical efficiency
P : Lead [m] μ : Coefficient of friction
F : External force [N] g : Acceleration of gravity 9.8 [m/s²]

Belt mechanism

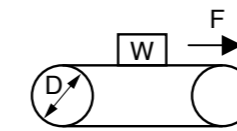

Traveling torque $T_f = \frac{D}{2\eta} (\mu g W + F)$

W : Weight [kg] η : Mechanical efficiency
P : Pulley diameter [m] μ : Coefficient of friction
F : External force [N] g : Acceleration of gravity 9.8 [m/s²]

(3) Effective torque

Indicates a root-mean-square value of the total torque required for running and stopping the motor per unit time. The reference value is approx. 80 % or less of the rated motor torque.

$$T_{rms} = \sqrt{\frac{T_a^2 \times t_a + T_f^2 \times t_b + T_d^2 \times t_d}{t_c}}$$

T_a : Acceleration torque [N·m] t_a : Acceleration time [s] t_c : Cycle time [s]
T_f : Traveling torque [N·m] t_b : Constant-velocity time [s] (Run time + Stop time)
T_d : Deceleration torque [N·m] t_d : Deceleration time [s]

2. Motor velocity

Maximum velocity

Maximum velocity of motor in operation: The reference value is the rated velocity or lower value.

When the motor runs at the maximum velocity, you must pay attention to the motor torque and temperature rise.

For actual calculation of motor velocity, see "Example of motor selection" described later.

Selecting motor capacity

Description on the items related to motor selection

3. Inertia and inertia ratio

Inertia is like the force to retain the current moving condition.

Inertia ratio is calculated by dividing load inertia by rotor inertia.

Generally, for motors with 750 W or lower capacity, the inertia ratio should be "20" or less. For motors with 1000 W or higher capacity, the inertia ratio should be "10" or less.

If you need quicker response, a lower inertia ratio is required.

(For example, when the motor takes several seconds in acceleration step, the inertia ratio can be further increased.)

General inertia calculation method

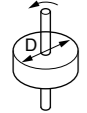
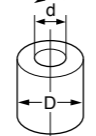
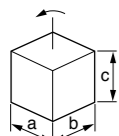
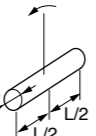
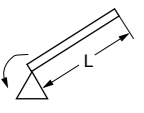
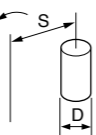
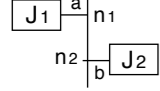
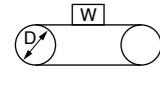
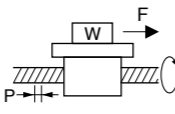
Shape	J calculation formula	Shape	J calculation formula
 Disk	$J = \frac{1}{8} W D^2 \text{ [kg}\cdot\text{m}^2]$ <p>W : Weight [kg] D : Outer diameter [m]</p>	 Hollow cylinder	$J = \frac{1}{8} W (D^2 + d^2) \text{ [kg}\cdot\text{m}^2]$ <p>W : Weight [kg] D : Outer diameter [m] d : Inner diameter [m]</p>
 Prism	$J = \frac{1}{12} W (a^2 + b^2) \text{ [kg}\cdot\text{m}^2]$ <p>W : Weight [kg] a, b, c : Side length [m]</p>	 Uniform rod	$J = \frac{1}{48} W (3D^2 + 4L^2) \text{ [kg}\cdot\text{m}^2]$ <p>W : Weight [kg] D : Outer diameter [m] L : Length [m]</p>
 Straight rod	$J = \frac{1}{3} W L^2 \text{ [kg}\cdot\text{m}^2]$ <p>W : Weight [kg] L : Length [m]</p>	 Separated rod	$J = \frac{1}{8} W D^2 + W S^2 \text{ [kg}\cdot\text{m}^2]$ <p>W : Weight [kg] D : Outer diameter [m] S : Distance [m]</p>
 Reduction gear	Inertia on shaft "a" $J = J_1 + \left(\frac{n_2}{n_1}\right)^2 J_2 \text{ [kg}\cdot\text{m}^2]$ <p>n₁ : A rotational speed of a shaft [r/min] n₂ : A rotational speed of b shaft [r/min]</p>		
 Conveyor	$J = \frac{1}{4} W D^2 \text{ [kg}\cdot\text{m}^2]$ <p>W : Workpiece weight on conveyor [kg] D : Drum diameter [m] * Excluding drum J</p>	 Ball screw	$J = J_B + \frac{W \cdot P^2}{4\pi^2} \text{ [kg}\cdot\text{m}^2]$ <p>W : Weight [kg] P : Lead [m] J_B : J of ball screw</p>

If weight (W [kg]) is unknown, calculate it with the following formula:

Weight W [kg] = Density ρ [kg/m³] × Volume V [m³]

Density of each material

Iron ρ = 7.9 × 10³ [kg/m³] Aluminum ρ = 2.8 × 10³ [kg/m³]

Brass ρ = 8.5 × 10³ [kg/m³]

To drive ball screw mechanism

1. Example of motor selection for driving ball screw mechanism

Workpiece weight **W_A = 10 [kg]**
 Ball screw length **BL = 0.5 [m]**
 Ball screw diameter **BD = 0.02 [m]**
 Ball screw lead **BP = 0.02 [m]**
 Ball screw efficiency **B_η = 0.9**
 Travel distance **0.3 [m]**
 Coupling inertia **J_c = 10 × 10⁻⁶ [kg·m²]** (Use manufacturer-specified catalog value, or calculation value.)

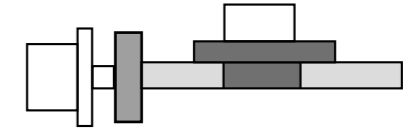

2. Running pattern :

Acceleration time **t_a = 0.7 [s]**
 Constant-velocity time **t_b = 1.3 [s]**
 Deceleration time **t_d = 0.7 [s]**
 Cycle time **t_c = 4 [s]**
 Travel distance **0.3 [m]**

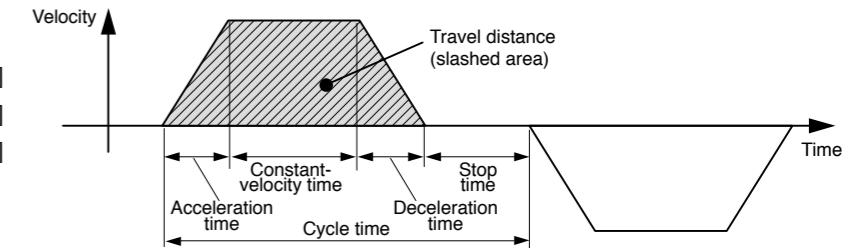

3. Ball screw weight

$$B_W = \rho \times \pi \times \left(\frac{BD}{2}\right)^2 \times BL = 7.9 \times 10^3 \times \pi \times \left(\frac{0.02}{2}\right)^2 \times 0.5 = 1.24 \text{ [kg]}$$

4. Load inertia

$$J_L = J_c + J_B + J_W = J_c + \frac{1}{8} B_W \times BD^2 + \frac{W_A \cdot BP^2}{4\pi^2} = 0.00001 + (1.24 \times 0.02^2) / 8 + 10 \times 0.02^2 / 4\pi^2 = 1.73 \times 10^{-4} \text{ [kg}\cdot\text{m}^2]$$

5. Provisional motor selection

In case of GP series 50 W, gear ratio 1/5. Permissible load inertia moment = 3.42 × 10⁻⁴ [kg·m²]

6. Inertia moment compared

Permissible load inertia moment = 3.42 × 10⁻⁴ [kg·m²] > Load inertia = 1.73 × 10⁻⁴ [kg·m²] Cleared specification

7. Calculation of maximum velocity (V_{max})

$$\frac{1}{2} \times \text{Acceleration time} \times V_{\max} + \text{Constant-velocity time} \times V_{\max} + \frac{1}{2} \times \text{Deceleration time} \times V_{\max} = \text{Travel distance}$$

$$\frac{1}{2} \times 0.7 \times V_{\max} + 1.3 \times V_{\max} + \frac{1}{2} \times 0.7 \times V_{\max} = 0.3$$

$$2.0 \times V_{\max} = 0.3$$

$$V_{\max} = 0.3 / 2.0 = 0.15 \text{ [m/s]}$$

8. Calculation of motor velocity (N [r/min]) Ball screw lead per resolution: BP = 0.02 [m]

$$N = 0.15 / 0.02 = 7.5 \text{ [r/s]}$$

$$= 7.5 \times 60 = 450 \text{ [r/min]} < 600 \text{ [r/min]} \text{ (rated rotation speed of GP series 50 W, gear ratio 1/5)}$$

9. Calculation of torque

$$\text{Traveling torque } T_f = \frac{BP}{2\pi B_\eta} (\mu g W_A + F) = \frac{0.02}{2\pi \times 0.9} (0.1 \times 9.8 \times 10 + 0) = 0.035 \text{ [N}\cdot\text{m]}$$

$$\text{Acceleration torque } T_a = \frac{J_L \times 2\pi N \text{ [r/s]}}{\text{Acceleration time [s]}} + \text{Traveling torque} = \frac{1.73 \times 10^{-4} \times 2\pi \times 7.5}{0.7} + 0.035 = 0.012 + 0.035 = 0.047 \text{ [N}\cdot\text{m]}$$

$$\text{Deceleration torque } T_d = \frac{J_L \times 2\pi N \text{ [r/s]}}{\text{Deceleration time [s]}} - \text{Traveling torque} = \frac{1.73 \times 10^{-4} \times 2\pi \times 7.5}{0.7} - 0.035 = 0.012 - 0.035 = -0.023 \text{ [N}\cdot\text{m]}$$

Selecting motor capacity

10. Verification of maximum torque

Acceleration torque = T_a
 $= 0.047 \text{ [N}\cdot\text{m]} < 0.71 \text{ [N}\cdot\text{m]}$ (GP series 50 W, 1/5 gear, Permissible torque at output shaft of gear head)

11. Verification of effective torque

$$T_{rms} = \sqrt{\frac{T_a^2 \times t_a + T_r^2 \times t_b + T_d^2 \times t_d}{t_c}}$$

$$= \sqrt{\frac{0.047^2 \times 0.7 + 0.035^2 \times 1.3 + (-0.023)^2 \times 0.7}{4}}$$

$$= 0.030 \text{ [N}\cdot\text{m]} < 0.71 \text{ [N}\cdot\text{m]}$$
 (GP series 50 W, 1/5 gear, Permissible torque at output shaft of gear head)

12. Load torque, load inertia moment are cleared specification.

Example of motor selection for timing belt mechanism

1. Mechanism

Workpiece weight $W_A = 2 \text{ [kg]}$ (including belt)
 Pulley diameter $P_D = 0.05 \text{ [m]}$
 Pulley weight $W_P = 0.5 \text{ [kg]}$ (Use manufacturer-specified catalog value, or calculation value.)
 Mechanical efficiency $B_\eta = 0.8$
 Coupling inertia $J_c = 0$ (Direct connection to motor shaft)

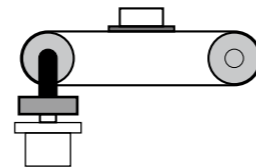

2. Running pattern

Acceleration time $t_a = 1.0 \text{ [s]}$
 Constant-velocity time $t_b = 1.0 \text{ [s]}$
 Deceleration time $t_d = 1.0 \text{ [s]}$
 Cycle time $t_c = 4 \text{ [s]}$
 Travel distance 1 [m]

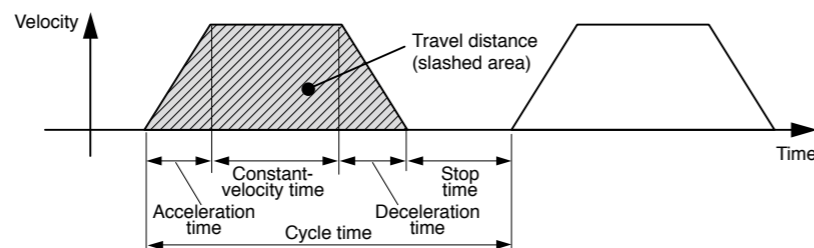

3. Load inertia

$$J_L = J_c + J_B + J_P$$

$$= J_c + \frac{1}{4} W_A \times P_D^2 + \frac{1}{8} W_P \times P_D^2 \times 2$$

$$= 0 + \frac{1}{4} \times 2 \times 0.05^2 + \frac{1}{8} \times 0.5 \times 0.05^2 \times 2$$

$$= 0.00156 = 15.6 \times 10^{-4} \text{ [kg}\cdot\text{m}^2]$$

4. Provisional motor selection

In case of GP series 50 W, gear ratio 1/15. Permissible load inertia moment = $30.6 \times 10^{-4} \text{ [kg}\cdot\text{m}^2]$

5. Inertia moment compared

$$30.6 \times 10^{-4} \text{ [kg}\cdot\text{m}^2] > 15.6 \times 10^{-4} \text{ [kg}\cdot\text{m}^2]$$

6. Calculation of maximum velocity (Vmax)

$$\frac{1}{2} \times \text{Acceleration time} \times V_{max} + \text{Constant-velocity time} \times V_{max} + \frac{1}{2} \times \text{Deceleration time} \times V_{max} = \text{Travel distance}$$

$$\frac{1}{2} \times 1.0 \times V_{max} + 1.0 \times V_{max} + \frac{1}{2} \times 1.0 \times V_{max} = 1$$

$$2.0 \times V_{max} = 1$$

$$V_{max} = 1 / 2.0 = 0.5 \text{ [m/s]}$$

7. Calculation of motor velocity (N [r/min])

A single rotation of pulley : $\pi \times P_D = 0.157 \text{ [m]}$
 $N = 0.5 / 0.157 = 3.18 \text{ [r/s]}$
 $= 3.18 \times 60 = 191 \text{ [r/min]} < 200 \text{ [r/min]}$ (rated rotation speed of GP series 50 W, gear ratio 1/15)

8. Calculation of torque

$$\text{Traveling torque } T_r = \frac{P_D}{2\eta} (\mu g W_A + F) = \frac{0.05}{2 \times 0.8} (0.1 \times 9.8 \times 2 + 0)$$

$$= 0.061 \text{ [N}\cdot\text{m]}$$

$$\text{Acceleration torque } T_a = \frac{J_L \times 2\pi N \text{ [r/s]}}{\text{Acceleration time [s]}} + \text{Traveling torque}$$

$$= \frac{15.6 \times 10^{-4} \times 2\pi \times 3.18}{1.0} + 0.061$$

$$= 0.031 + 0.061 = 0.092 \text{ [N}\cdot\text{m]}$$

$$\text{Deceleration torque } T_d = \frac{J_L \times 2\pi N \text{ [r/s]}}{\text{Deceleration time [s]}} - \text{Traveling torque}$$

$$= \frac{15.6 \times 10^{-4} \times 2\pi \times 3.18}{1.0} - 0.061$$

$$= 0.031 - 0.061 = -0.03 \text{ [N}\cdot\text{m]}$$

9. Verification of maximum torque

Acceleration torque
 $T_a = 0.092 \text{ [N}\cdot\text{m]} < 2.2 \text{ [N}\cdot\text{m]}$ (GP series 50 W, 1/15 gear, Permissible torque at output shaft of gear head)

10. Verification of effective torque

$$T_{rms} = \sqrt{\frac{T_a^2 \times t_a + T_r^2 \times t_b + T_d^2 \times t_d}{t_c}}$$

$$= \sqrt{\frac{0.092^2 \times 1.0 + 0.061^2 \times 1.0 + (-0.03)^2 \times 1.0}{4}}$$

$$= 0.057 \text{ [N}\cdot\text{m]} < 2.2 \text{ [N}\cdot\text{m]}$$
 (GP series 50 W, 1/15 gear, Permissible torque at output shaft of gear head)

11. A GP series 50 W, 1/15 gear selected by following the above procedure will cause no problem.

Request sheet for motor selection

Request for motor selection I : Ball screw drive

1. Driven mechanism and running data

- 1) Travel distance of the work load per one cycle mm
- 2) Cycle time s
- (Fill in items 3) and 4) if required.)
- 3) Acceleration time s
- 4) Deceleration time s
- 5) Stopping time s
- 6) Max. velocity mm/s
- 7) External force N
- 8) Positioning accuracy of the work load mm
- 9) Total weight of the work load and the table kg
- 10) Power supply voltage
- 11) Diameter of the ball screw
- 12) Total length of the ball screw
- 13) Lead of the ball screw

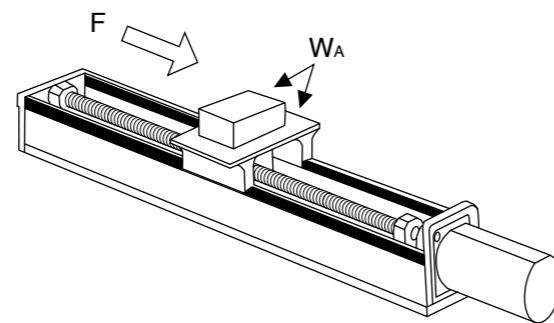
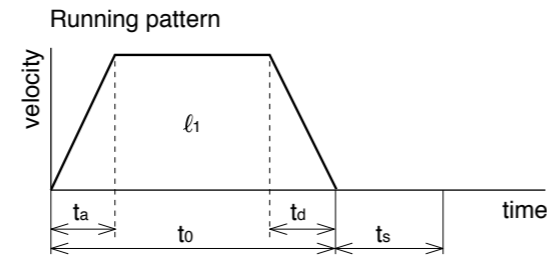

14) Traveling direction (horizontal, vertical etc.)

2. Other data (Fill the details on specific mechanism and its configurations in the following blank.)

Company name : _____

Department/Section : _____

Name : _____

Address : _____

Tel : _____

Fax : _____

E-mail address: _____

Request sheet for motor selection

Request for motor selection II : Timing pulley + Ball screw drive

1. Driven mechanism and running data

- | | | | | | | | | | | | | | | | | | | | | | | |
|---|--|---|------------|-----------------|----------------------------|---|---|--------------------------|---|---|--|-----------------------|--|-------------------------|---|--|----------------------------|---|--|------------------------|---|--|
| <ol style="list-style-type: none"> 1) Travel distance of the work load per one cycle <input style="width: 80px;" type="text" value="l<sub>1</sub>:"/> mm 2) Cycle time <input style="width: 80px;" type="text" value="t<sub>0</sub>:"/> s <li style="padding-left: 20px;">(Fill in items 3) and 4) if required.) 3) Acceleration time <input style="width: 80px;" type="text" value="t<sub>a</sub>:"/> s 4) Deceleration time <input style="width: 80px;" type="text" value="t<sub>d</sub>:"/> s 5) Stopping time <input style="width: 80px;" type="text" value="t<sub>s</sub>:"/> s 6) Max. velocity <input style="width: 80px;" type="text" value="V:"/> mm/s 7) External force <input style="width: 80px;" type="text" value="F:"/> N 8) Positioning accuracy of the work load <input style="width: 80px;" type="text" value="±"/> mm 9) Total weight of the work load and the table <input style="width: 80px;" type="text" value="W<sub>A</sub>:"/> kg 10) Power supply voltage <input style="width: 80px;" type="text" value="V"/> 11) Diameter of the ball screw <input style="width: 80px;" type="text" value="mm"/> 12) Total length of the ball screw <input style="width: 80px;" type="text" value="mm"/> 13) Lead of the ball screw <input style="width: 80px;" type="text" value="mm"/> 14) Traveling direction (horizontal, vertical etc.) <input style="width: 150px; height: 20px;" type="text"/> | <table border="0" style="width: 100%; border-collapse: collapse;"> <tr> <td style="width: 50%;"></td> <td style="width: 25%; text-align: center;">Motor side</td> <td style="width: 25%; text-align: center;">Ball screw side</td> </tr> <tr> <td>15) Diameter of the pulley</td> <td style="text-align: center;"><input style="width: 80px;" type="text" value="D<sub>1</sub>:"/> mm</td> <td style="text-align: center;"><input style="width: 80px;" type="text" value="D<sub>2</sub>:"/> mm</td> </tr> <tr> <td>16) Weight of the pulley</td> <td style="text-align: center;"><input style="width: 80px;" type="text" value="W<sub>1</sub>:"/> kg</td> <td style="text-align: center;"><input style="width: 80px;" type="text" value="W<sub>2</sub>:"/> kg</td> </tr> <tr> <td></td> <td colspan="2" style="text-align: center;">(or item 17) and 18))</td> </tr> <tr> <td>17) Width of the pulley</td> <td colspan="2" style="text-align: center;"><input style="width: 80px;" type="text" value="L<sub>1</sub>:"/> mm</td> </tr> <tr> <td>18) Material of the pulley</td> <td colspan="2" style="text-align: center;"><input style="width: 80px;" type="text"/></td> </tr> <tr> <td>19) Weight of the belt</td> <td colspan="2" style="text-align: center;"><input style="width: 80px;" type="text" value="W<sub>M</sub>:"/> kg</td> </tr> </table> | | Motor side | Ball screw side | 15) Diameter of the pulley | <input style="width: 80px;" type="text" value="D<sub>1</sub>:"/> mm | <input style="width: 80px;" type="text" value="D<sub>2</sub>:"/> mm | 16) Weight of the pulley | <input style="width: 80px;" type="text" value="W<sub>1</sub>:"/> kg | <input style="width: 80px;" type="text" value="W<sub>2</sub>:"/> kg | | (or item 17) and 18)) | | 17) Width of the pulley | <input style="width: 80px;" type="text" value="L<sub>1</sub>:"/> mm | | 18) Material of the pulley | <input style="width: 80px;" type="text"/> | | 19) Weight of the belt | <input style="width: 80px;" type="text" value="W<sub>M</sub>:"/> kg | |
| | Motor side | Ball screw side | | | | | | | | | | | | | | | | | | | | |
| 15) Diameter of the pulley | <input style="width: 80px;" type="text" value="D<sub>1</sub>:"/> mm | <input style="width: 80px;" type="text" value="D<sub>2</sub>:"/> mm | | | | | | | | | | | | | | | | | | | | |
| 16) Weight of the pulley | <input style="width: 80px;" type="text" value="W<sub>1</sub>:"/> kg | <input style="width: 80px;" type="text" value="W<sub>2</sub>:"/> kg | | | | | | | | | | | | | | | | | | | | |
| | (or item 17) and 18)) | | | | | | | | | | | | | | | | | | | | | |
| 17) Width of the pulley | <input style="width: 80px;" type="text" value="L<sub>1</sub>:"/> mm | | | | | | | | | | | | | | | | | | | | | |
| 18) Material of the pulley | <input style="width: 80px;" type="text"/> | | | | | | | | | | | | | | | | | | | | | |
| 19) Weight of the belt | <input style="width: 80px;" type="text" value="W<sub>M</sub>:"/> kg | | | | | | | | | | | | | | | | | | | | | |

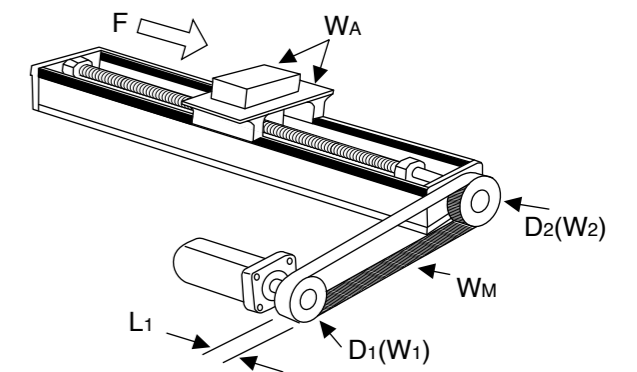
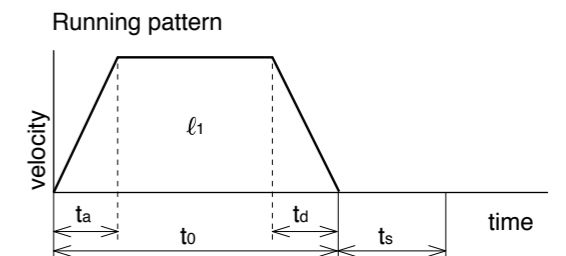

2. Other data (Fill the details on specific mechanism and its configurations in the following blank.)

Company name : _____

Department/Section : _____

Name : _____

Address : _____

Tel : _____

Fax : _____

E-mail address: _____

Request sheet for motor selection

Request for motor selection III : Belt drive

1. Driven mechanism and running data

- 1) Travel distance of the work load per one cycle mm
- 2) Cycle time s
(Fill in items 3) and 4) if required.)
- 3) Acceleration time s
- 4) Deceleration time s
- 5) Stopping time s
- 6) Max. velocity mm/s
- 7) External force N
- 8) Positioning accuracy of the work load mm
- 9) Total weight of the work load kg
- 10) Power supply voltage V
- 11) Weight of the belt kg
- 12) Diameter of the driving pulley mm
- 13) Total weight of the pulley kg

Running pattern

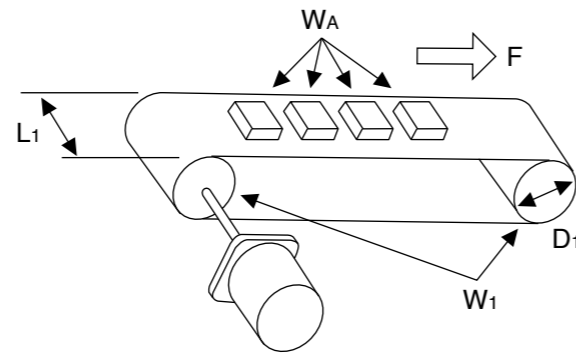
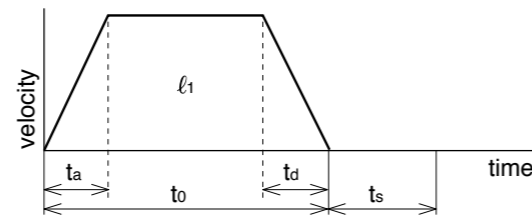

(or item 14) and 15))

- 14) Width of the pulley mm
- 15) Material of the pulley
- 16) Traveling direction (horizontal, vertical etc.)

2. Other data (Fill the details on specific mechanism and its configurations in the following blank.)

Company name :
Department/Section :
Name :
Address :
Tel :
Fax :
E-mail address:

Request sheet for motor selection

Request for motor selection IV : Timing pulley + Belt drive

1. Driven mechanism and running data

- 1) Travel distance of the work load per one cycle mm
- 2) Cycle time s
(Fill in items 3) and 4) if required.)
- 3) Acceleration time s
- 4) Deceleration time s
- 5) Stopping time s
- 6) Max. velocity mm/s
- 7) External force N
- 8) Positioning accuracy of the work load mm
- 9) Total weight of the work load kg
- 10) Power supply voltage V
- 11) Weight of motor side belt kg

- | | Motor side | Belt side |
|----------------------------|---------------------|---------------------|
| 16) Diameter of the pulley | D ₃ : mm | D ₄ : mm |
| 17) Weight of the pulley | W ₃ : kg | W ₄ : kg |

(or item 18) and 19))

- 18) Width of the pulley mm
- 19) Material of the pulley
- 20) Weight of the belt kg
- 21) Traveling direction (horizontal, vertical etc.)

Running pattern

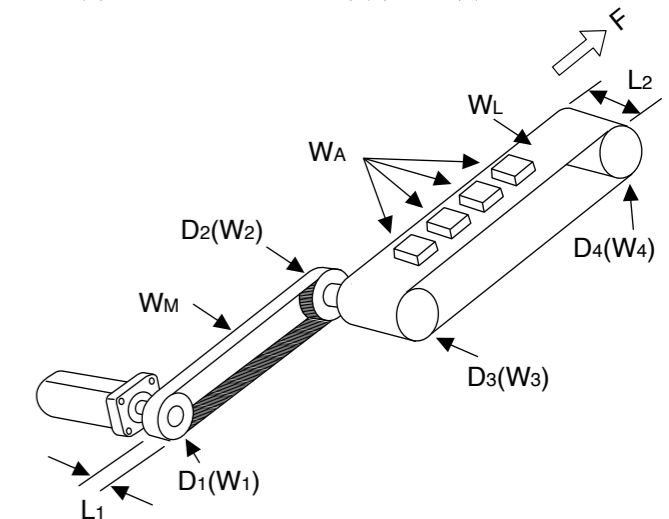
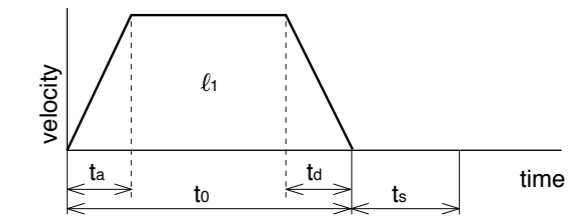

- | | Motor side | Belt side |
|----------------------------|---------------------|---------------------|
| 12) Diameter of the pulley | D ₁ : mm | D ₂ : mm |
| 13) Weight of the pulley | W ₁ : kg | W ₂ : kg |
- (or item 14) and 15))
- 14) Width of the belt mm
 - 15) Material of the pulley

2. Other data (Fill the details on specific mechanism and its configurations in the following blank.)

Company name :
Department/Section :
Name :
Address :
Tel :
Fax :
E-mail address:

Request sheet for motor selection

Request for motor selection V : Turntable drive

1. Driven mechanism and running data

- 1) Travel distance of the work load per one cycle
- 2) Cycle time
- (Fill in items 3) and 4) if required.)
- 3) Acceleration time
- 4) Deceleration time
- 5) Stopping time
- 6) Max. rotational speed of the table
(or)
- 7) Positioning accuracy of the work load
- 8) Weight of one work load
- 9) Driving radius of the center of gravity of the work
- 10) Diameter of the table
- 11) Mass of the table
- 12) Diameter of the table support
- 13) Power supply voltage

- | | Prism | Cylinder |
|---------------------------------|------------------------------------|------------------------------------|
| 14) Dimensions of the work load | a: <input type="text" value="mm"/> | a: <input type="text" value="mm"/> |
| | b: <input type="text" value="mm"/> | b: <input type="text" value="mm"/> |
| | c: <input type="text" value="mm"/> | c: <input type="text" value="mm"/> |
| 15) Number of work loads | <input type="text" value="pcs"/> | |

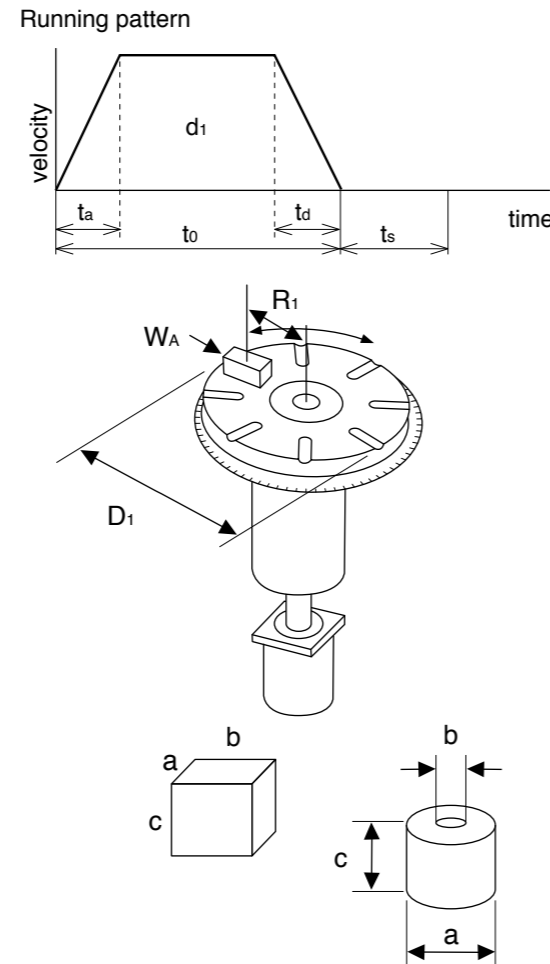

2. Other data (Fill the details on specific mechanism and its configurations in the following blank.)

Company name : _____
 Department/Section : _____
 Name : _____
 Address : _____
 Tel : _____
 Fax : _____
 E-mail address: _____

Request sheet for motor selection

Request for motor selection VI : Timing pulley + Turntable drive

1. Driven mechanism and running data

- 1) Travel distance of the work load per one cycle
- 2) Cycle time
- (Fill in items 3) and 4) if required.)
- 3) Acceleration time
- 4) Deceleration time
- 5) Stopping time
- 6) Max. rotational speed of the table
(or)
- 7) Positioning accuracy of the work load
- 8) Weight of one work load
- 9) Driving radius of the center of gravity of the work
- 10) Diameter of the table
- 11) Mass of the table
- 12) Diameter of the table support
- 13) Power supply voltage

- | | (Prism) | (Cylinder) |
|--------------------------------|------------------------------------|------------------------------------|
| 14) Dimension of the work load | a: <input type="text" value="mm"/> | a: <input type="text" value="mm"/> |
| | b: <input type="text" value="mm"/> | b: <input type="text" value="mm"/> |
| | c: <input type="text" value="mm"/> | c: <input type="text" value="mm"/> |
| 15) Number of work loads | <input type="text" value="pcs"/> | |

- | | Motor side | Turntable side |
|----------------------------|-------------------------------------|-------------------------------------|
| 16) Diameter of the pulley | D2: <input type="text" value="mm"/> | D3: <input type="text" value="mm"/> |
| 17) Weight of the pulley | W2: <input type="text" value="kg"/> | W3: <input type="text" value="kg"/> |
| (or item 18) and 19) | | |
| 18) Width of the pulley | L1: <input type="text" value="mm"/> | |
| 19) Material of the pulley | <input type="text"/> | |
| 20) Weight of the belt | WM: <input type="text" value="kg"/> | |

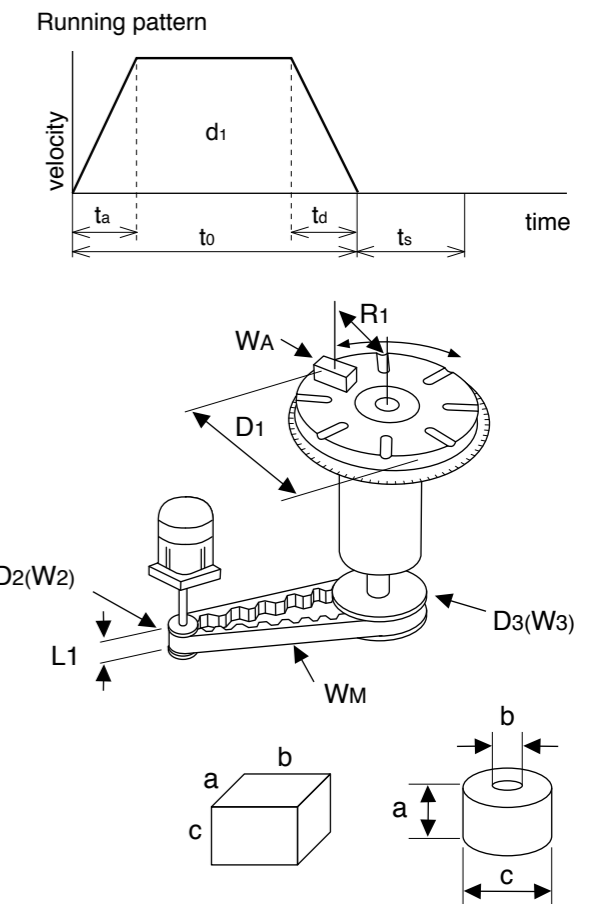

2. Other data (Fill the details on specific mechanism and its configurations in the following blank.)

Company name : _____
 Department/Section : _____
 Name : _____
 Address : _____
 Tel : _____
 Fax : _____
 E-mail address: _____

Request sheet for motor selection

Request for motor selection VII : Roller feed drive

1. Driven mechanism and running data

- 1) Travel distance of the work load per one cycle l_1 : mm
- 2) Cycle time to: s
- (Fill in items 3) and 4) if required.)
- 3) Acceleration time ta: s
- 4) Deceleration time td: s
- 5) Stopping time ts: s
- 6) Max. velocity v: mm/s
- 7) External pulling force F: N
- 8) Positioning accuracy of the work load ± mm
- 9) Number of rollers pcs
- 10) Power supply voltage V
- 11) Diameter of the roller D₁: mm
- 12) Mass of the roller W₁: kg

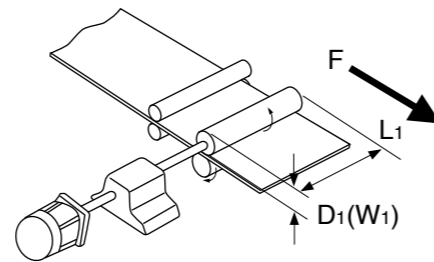
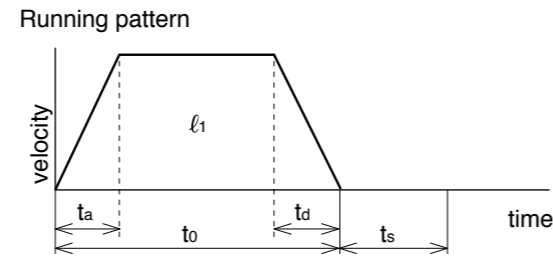

(or item 13) and 14))

- 13) Width of the roller L₁: mm
- 14) Material of the roller

2. Other data (Fill the details on specific mechanism and its configurations in the following blank.)

Company name : _____

Department/Section : _____

Name : _____

Address : _____

Tel : _____

Fax : _____

E-mail address: _____

Request sheet for motor selection

Request for motor selection VIII : Driving with Rack & Pinion

1. Driven mechanism and running data

- 1) Travel distance of the work load per one cycle l_1 : mm
- 2) Cycle time to: s
- (Fill in items 3) and 4) if required.)
- 3) Acceleration time ta: s
- 4) Deceleration time td: s
- 5) Stopping time ts: s
- 6) Max. velocity V: mm/s
- 7) External force F: N
- 8) Positioning accuracy of the work load ± mm
- 9) Total weight of the work load W_A: kg
- 10) Power supply voltage V
- 11) Diameter of the pinion D₃: mm
- 12) Mass of the pinion W₃: kg
- 13) Traveling direction (horizontal, vertical, etc.)

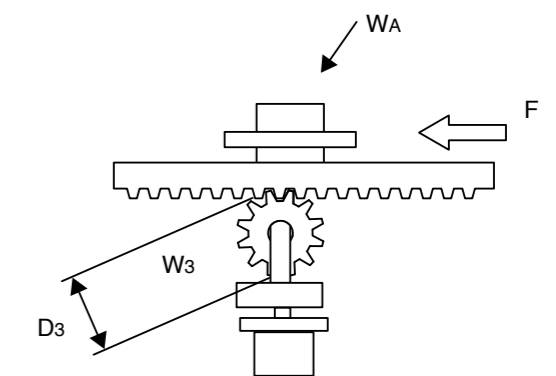
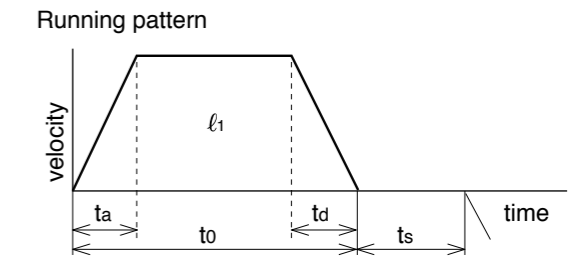

2. Other data (Fill the details on specific mechanism and its configurations in the following blank.)

Company name : _____

Department/Section : _____

Name : _____

Address : _____

Tel : _____

Fax : _____

E-mail address: _____

Conformance to international safety standards

Conformance to international standards

EC Directives

The EC directives apply to all such electronic products as those having specific functions and directly sold to general consumers in EU countries. These products are required to meet the EU unified standards and to be furnished with CE marking. Our brushless motor and brushless amplifier meet the EC Directives for Low Voltage Equipment so that the machine or equipment comprising our brushless motor and brushless amplifier can meet relevant EC Directives.

Conformity to UL Standards

Observe the following conditions of (1) and (2) to make the system conform to UL508C (E164620).

- Use the driver in an environment of Pollution Degree 2 or 1 prescribed in IEC60664-1.
(e.g. Install in the control box with IP54 enclosure.)
- Make sure to install a circuit breaker or fuse which are UL recognized (Listed  marked) between the power supply and the noise filter.
Use a copper cable with temperature rating of 75 °C or higher.

EMC Directives

Our brushless motor and brushless amplifier can meet EMC Directives and related standards. However, to meet these requirements, the systems must be limited with respect to configuration and other aspects, e.g. the installation and some special wiring conditions must be met. This means that in some cases machines and equipment comprising our brushless motor and brushless amplifier may not satisfy the requirements for wiring and grounding conditions specified by the EMC Directives. Therefore, conformance to the EMC Directives (especially the requirements for emission noise and noise terminal voltage) should be examined based on the final products that include our system.

	Applicable standards		Installation condition
UL	UL1004 UL508C	Standard for electric motor Standard for electric converter equipment	Class I equipment Pollution degree 2 SCCR *1
CSA (c-UL)	C22.2 No.14 C22.2 No.100	Industrial control equipment. Standard for electric motor	
CE	EN61800-5-1	Adjustable speed electrical power drive systems. – Safety requirements. Electrical, thermal and energy	Overvoltage category II Class I equipment Pollution degree 2 Group 1 Class A Category III 2nd environment
	EN60034-1	Standard for rotary electric machine (low voltage directive)	
	EN60034-5	Standard for rotary electric machine (low voltage directive)	
	EN61800-3	Adjustable speed electrical power drive systems. – EMC requirements and specific test methods	
CE	EN55011	Radio interference wave characteristics of industrial, scientific, and medical high-frequency equipment	Class A Instrument (commercial broadcast communications equipment)
	EN61000-6-2	Standards for immunity in industrial environment (EMC directive)	
CCC	GB12350	Motor safety standard	–
KC	Radio Waves Act (South Korea) (KC) *2	Class A Instrument (commercial broadcast communications equipment)	–

- *1 SCCR: Symmetrical current 5,000 Arms, Max. 240 V
Motor over-temperature protection is not provided.
Motor over-load-temperature protection shall be provided at the final installation upon required by the NEC (National Electric Code).
- *2 Information related to the Korea Radio Law
This brushless amplifier is a Class A commercial broadcasting radio wave generator not designed for home use. The user and dealer should be aware of this fact.

A 급 기기 (업무용 방송통신기자재)
이 기기는 업무용(A 급) 전자파적합기기로서 판매자 또는 사용자는 이 점을 주의하시기 바라며, 가정외의 지역에서 사용하는 것을 목적으로 합니다.

(대상기종 : Brushless Amplifier)

Configuration of peripheral equipment

Power supply	<ul style="list-style-type: none"> 100 V system: Single phase 100 V ± 10 % to 120 V ± 10 %, 50 Hz/60 Hz 200 V system: Single/3-phase 200 V ± 10 % to 240 V ± 10 %, 50 Hz/60 Hz Use the equipment under the environment of overvoltage category II specified by IEC60664-1. In order to obtain overvoltage category III, insert a transformer conforming to EN standard or IEC standard to the input of brushless motor. Use an electric wire size suitable to EN60204-1.
MCCB (breaker) Fuse	Be sure to connect a specified MCCB certified by IEC standard and UL, or a fuse certified by UL between power supply and noise filter. Observance of this condition allows conformance with UL508C (file No. E164620).
Noise filter	When installing one noise filter at the power supply for more than one brushless motor used, contact the manufacturer of noise filter.
Surge absorber	Install a surge absorber on the primary side of noise filter. However, in performing the voltage resistance test of machine and equipment, be sure to remove the surge absorber; otherwise, the surge absorber may be ruptured.
Grounding	Be sure to connect the grounding Terminal of brushless amplifier and protective grounding wire (PE) of system for preventing electric shock. Do not tighten the grounding wires together but connect them individually.

Wiring of peripheral equipment

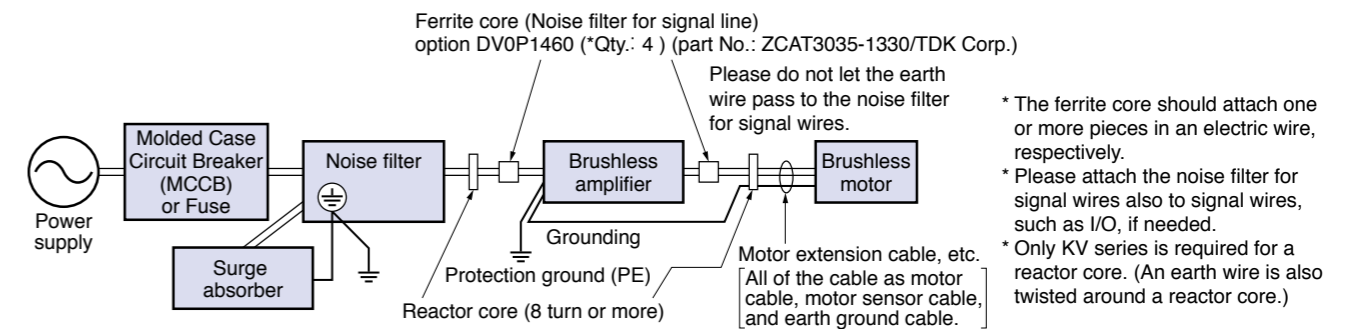

Reactor core (Recommended components)

- RJ8035

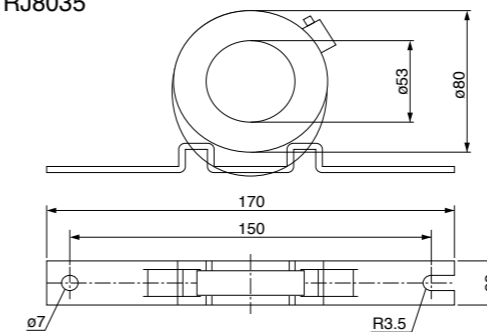

Current	100 kHz (μH)	Core thickness
35 A	9.9±3	24 mm

[Unit: mm]

List of compatible peripheral equipment

Part name	Optional parts number (option)	Manufacturer's parts number	Qty.	Manufacturer	Reference page
Noise filter (single phase 100 V, 200 V)	DV0P4170	SUP-EK5-ER-6	1	OKAYA ELECTRIC IND. CO., LTD.	P.67
Noise filter (3-phase)	DV0PM20042	3SUP-HU10-ER-6	1		
Surge absorber (single phase 100 V, 200 V)	DV0P4190	R·A·V-781BWZ-4	1		
Surge absorber (3-phase)	DV0P1450	R·A·V-781BXZ-4	1	TDK Corporation	P.94
Noise filter for control signals	DV0P1460	ZCAT3035-1330	4		
Reactor core	–	RJ8035	–	KK-CORP.CO.JP	

Table of model numbers and options

GV series

Power supply	Rated rotation speed (r/min)	output (W)	Motor	Gear head (Note 1)	Brushless amplifier	Brushless amplifier (supplied with power cable) (Note 2)	External regenerative resistor	Noise filter	Surge absorber	Reactor		Motor extension cable	Power supply connector kit	Console A	Console A connection cable	Digital key pad	Digital key pad connection cable	External speed setter	Control signal cable	I/O connector kit	Panel connector kit	PC connection cable (Note 4)	Noise filter for signal line	DIN rail attachment unit
Single phase 100 V	3000	50	MBMU5AZAX	MX8G□B	MBEG5A1BCV	MBEG5A1BCVC	for 100 V DV0P2890	for single phase power supply DV0P4170	for single phase power supply DV0P4190	for single phase power supply DV0P227		1 m DV0PQ1000110 3 m DV0PQ1000130 5 m DV0PQ1000150 10 m DV0PQ10001A1	DV0P2870	DV0P3500	1 m DV0PM2006910 3 m DV0PM2006930 5 m DV0PM2006950	DV0P3510	1 m DV0P38310 3 m DV0P38330 5 m DV0P38350	DV0PM20078	2 m DV0PM20076	DV0PM20070	DV0P3610	1.5 m DV0P4140	DV0P1460	DV0P3811
			MBMU5AZAS	—																				
		90	MBMU9A1AZ	MZ9G□B MY9G□B	MBEG9A1BCV	MBEG9A1BCVC																		
			MBMU9A1AS	—																				
		130	MBMU1E1AZ	MZ9G□B MY9G□B	MBEG1E1BCV	MBEG1E1BCVC																		
			MBMU1E1AS	—																				
Single phase/ 3-phase 200 V	3000	50	MBMU5AZAX	MX8G□B	MBEG5A5BCV	MBEG5A5BCVC	for 200 V DV0PM20068	for single phase power supply DV0P4170 for 3-phase power supply DV0PM20042	for single phase power supply DV0P4190 for 3-phase power supply DV0P1450	for single phase power supply DV0P227 for 3-phase power supply DV0P220		1 m DV0PQ1000310 3 m DV0PQ1000330 5 m DV0PQ1000350 10 m DV0PQ10003A1	DV0P2870	DV0P3500	1 m DV0PM2006910 3 m DV0PM2006930 5 m DV0PM2006950	DV0P3510	1 m DV0P38310 3 m DV0P38330 5 m DV0P38350	DV0PM20078	2 m DV0PM20076	DV0PM20070	DV0P3610	1.5 m DV0P4140	DV0P1460	DV0P3811
			MBMU5AZAS	—																				
		90	MBMU9A2AZ	MZ9G□B MY9G□B	MBEG9A5BCV	MBEG9A5BCVC																		
			MBMU9A2AS	—																				
		130	MBMU1E2AZ	MZ9G□B MY9G□B	MBEG1E5BCV	MBEG1E5BCVC																		
			MBMU1E2AS	—																				

KV series

Power supply	Rated rotation speed (r/min)	output (W)	Motor (Note 3)	Gear head	Brushless amplifier	Brushless amplifier (supplied with power cable) (Note 2)	External regenerative resistor	Noise filter	Surge absorber	Reactor		Motor extension cable	Power supply connector kit	Console A	Console A connection cable	Digital key pad	Digital key pad connection cable	External speed setter	Control signal cable	I/O connector kit	Panel connector kit	PC connection cable (Note 4)	Noise filter for signal line	DIN rail attachment unit
Single phase 100 V	3000	50	MBMS5AZBL□	—	MBEK5A1BCV	MBEK5A1BCVC	for 100 V DV0P2890	for single phase power supply DV0P4170	for single phase power supply DV0P4190	for single phase power supply DV0P227		1 m DV0PQ1000310 3 m DV0PQ1000330 5 m DV0PQ1000350 10 m DV0PQ10003A1	DV0P2870	—	1 m DV0PM2006910 3 m DV0PM2006930 5 m DV0PM2006950	DV0P3510	1 m DV0P38310 3 m DV0P38330 5 m DV0P38350	DV0PM20078	2 m DV0PM20076	DV0PM20070	DV0P3610	1.5 m DV0P4140	DV0P1460	DV0P3811
		100	MBMS011BL□		MBEK011BCV	MBEK011BCVC				for single phase power supply DV0P228														—
		200	MBMS021BL□		MBEK021BCV	—				—														—
Single phase/ 3-phase 200 V	3000	50	MBMS5AZBL□	—	MBEK5A5BCV	MBEK5A5BCVC	for 200 V DV0PM20068	for single phase power supply DV0P4170 for 3-phase power supply DV0PM20042	for single phase power supply DV0P4190 for 3-phase power supply DV0P1450	for single phase power supply DV0P227 for 3-phase power supply DV0P220		1 m DV0PQ1000310 3 m DV0PQ1000330 5 m DV0PQ1000350 10 m DV0PQ10003A1	DV0P2870	DV0P3500	1 m DV0PM2006910 3 m DV0PM2006930 5 m DV0PM2006950	DV0P3510	1 m DV0P38310 3 m DV0P38330 5 m DV0P38350	DV0PM20078	2 m DV0PM20076	DV0PM20070	DV0P3610	1.5 m DV0P4140	DV0P1460	DV0P3811
		100	MBMS012BL□		MBEK015BCV	MBEK015BCVC				—														—
		200	MBMS022BL□		MBEK025BCV	—				—														—
3-phase 200 V	3000	400	MBMS042BL□	—	MBEK045BCV	—	for 200 V DV0PM20068	for 3-phase power supply DV0PM20042	for 3-phase power supply DV0P1450	for 3-phase power supply DV0P220		1 m DV0PQ1000310 3 m DV0PQ1000330 5 m DV0PQ1000350 10 m DV0PQ10003A1	—	—	—	—	—	—	—	—	—	—	—	
750	MBMS082BL□	MBEK083BCV	—		—	—																		

GP series

Power supply	Rated rotation speed (r/min)	output (W)	Motor	Gear head (Note 1)	Brushless amplifier	Brushless amplifier (supplied with power cable) (Note 2)	External regenerative resistor	Noise filter	Surge absorber	Reactor		Motor extension cable	Power supply connector kit	Console A	Console A connection cable	Digital key pad	Digital key pad connection cable	External speed setter	Control signal cable	I/O connector kit	Panel connector kit	PC connection cable (Note 4)	Noise filter for signal line	DIN rail attachment unit
Single phase 100 V	3000	50	MBMU5AZAB	MB8G□BV	MBEG5A1BCP	MBEG5A1BCPC	for 100 V DV0P2890	for single phase power supply DV0P4170	for single phase power supply DV0P4190	for single phase power supply DV0P227		1 m DV0PQ1000110 3 m DV0PQ1000130 5 m DV0PQ1000150 10 m DV0PQ10001A1	DV0P2870	—	—	DV0P3510	1 m DV0P38310 3 m DV0P38330 5 m DV0P38350	—	2 m DV0PM20076	DV0PM20070	—	1.5 m DV0P4140	DV0P1460	DV0P3811
		90	MBMU9A1AB	MB9G□BV	MBEG9A1BCP	MBEG9A1BCPC																		
		130	MBMU1E1AB	MB9G□BV	MBEG1E1BCP	MBEG1E1BCPC																		
Single phase/ 3-phase 200 V	3000	50	MBMU5AZAB	MB8G□BV	MBEG5A5BCP	MBEG5A5BCPC	for 200 V DV0PM20068	for single phase power supply DV0P4170 for 3-phase power supply DV0PM20042	for single phase power supply DV0P4190 for 3-phase power supply DV0P1450	for single phase power supply DV0P227 for 3-phase power supply DV0P220		1 m DV0PQ1000310 3 m DV0PQ1000330 5 m DV0PQ1000350 10 m DV0PQ10003A1	DV0P2870	—	—	DV0P3510	1 m DV0P38310 3 m DV0P38330 5 m DV0P38350	—	2 m DV0PM20076	DV0PM20070	—	1.5 m DV0P4140	DV0P1460	DV0P3811
		90	MBMU9A2AB	MB9G□BV	MBEG9A5BCP	MBEG9A5BCPC																		
		130	MBMU1E2AB	MB9G□BV	MBEG1E5BCP	MBEG1E5BCPC																		

(Note 1) A figure representing reduction ratio in □.

(Note 2) Refer to p. 74 for a power supply connecting cable.

This part number is the ordering part number for the amplifier and power cable, not for ordering amplifier only.

(Note 3) Suffix of “□” in the motor model represents shape of shaft. For more information, please refer to p. 27.

(Note 4) When connecting PC, the PC connection cable (DV0P4140) and the Digital key pad connection cable (DV0P383*0) are required.

If your PC does not have RS232 port, use RS232-USB converter.

● When installing the reactor, refer to p. 73.

● Be sure to use a set of matched components (series, power source, capacity, output, etc.)

Model No.	Specifications	Page
DV0P (Option)		
DV0P1450	Surge absorber (3-phase)	67
DV0P1460	Noise filter for control signals	67
DV0P220	Reactor	73
DV0P227	Reactor	73
DV0P228	Reactor	73
DV0P2870	Power supply connector kit	70
DV0P2890	External regenerative resistor 50 Ω for 100 V	71
DV0P3500	Console A	68
DV0P3510	Digital key pad	68
DV0P3610	Panel connector kit (Fits to Console A)	71
DV0P3811	DIN rail attachment unit	72
DV0P38310	Digital key pad connection cable 1 m	68
DV0P38330	Digital key pad connection cable 3 m	68
DV0P38350	Digital key pad connection cable 5 m	68
DV0P4140	PC connection cable (10-pin D-sub connector pin 1.5 m)	70
DV0P4170	Noise filter (single phase)	67
DV0P4190	Surge absorber (single phase)	67
DV0PM20042	Noise filter (3-phase)	67
DV0PM20068	External regenerative resistor 200 Ω for 200 V	71
DV0PM2006910	Console A connection cable 1 m	68
DV0PM2006930	Console A connection cable 3 m	68
DV0PM2006950	Console A connection cable 5 m	68
DV0PM20070	I/O connector kit	71
DV0PM20076	Control signal cable (cable with I/O connector)	70
DV0PM20078	External speed setter	71
DV0PN10008	O-ring for 80 mm sq. motor 10pcs / bag	25,65,74
DV0PN10009	O-ring for 90 mm sq. motor 10pcs / bag	25,65,74
DV0PQ1000110	Motor extension cable 1 m for GV, GP series	69
DV0PQ1000130	Motor extension cable 3 m for GV, GP series	69
DV0PQ1000150	Motor extension cable 5 m for GV, GP series	69
DV0PQ10001A1	Motor extension cable 10 m for GV, GP series	69
DV0PQ1000310	Motor extension cable 1 m for KV series	69
DV0PQ1000330	Motor extension cable 3 m for KV series	69
DV0PQ1000350	Motor extension cable 5 m for KV series	69
DV0PQ10003A1	Motor extension cable 10 m for KV series	69

Model No.	Specifications	Page
MB8G (For GP series gear head)		
MB8G10BV	80 mm sq. Reduction ratio: 1/10	57,63
MB8G15BV	80 mm sq. Reduction ratio: 1/15	57,63
MB8G20BV	80 mm sq. Reduction ratio: 1/20	57,63
MB8G30BV	80 mm sq. Reduction ratio: 1/30	57,63
MB8G50BV	80 mm sq. Reduction ratio: 1/50	57,63
MB8G5BV	80 mm sq. Reduction ratio: 1/5	57,63

Model No.	Specifications	Page
MB9G (For GP series gear head)		
MB9G10BV	90 mm sq. Reduction ratio: 1/10	59,61,63
MB9G15BV	90 mm sq. Reduction ratio: 1/15	59,61,63
MB9G20BV	90 mm sq. Reduction ratio: 1/20	59,61,63
MB9G30BV	90 mm sq. Reduction ratio: 1/30	59,61,63
MB9G50BV	90 mm sq. Reduction ratio: 1/50	59,61,63
MB9G5BV	90 mm sq. Reduction ratio: 1/5	59,61,63

Model No.	Specifications	Page
MBEG (For GP series amplifier)		
MBEG1E1BCP	130 W Single phase 100 V to 120 V	61
MBEG1E1BCPC	130 W Single phase 100 V to 120 V (Power cable included)*	61,74
MBEG1E5BCP	130 W Single/3-Phase 200 V to 240 V	61
MBEG1E5BCPC	130 W Single/3-Phase 200 V to 240 V (Power cable included)*	61,74
MBEG5A1BCP	50 W Single phase 100 V to 120 V	57
MBEG5A1BCPC	50 W Single phase 100 V to 120 V (Power cable included)*	57,74
MBEG5A5BCP	50 W Single/3-Phase 200 V to 240 V	57
MBEG5A5BCPC	50 W Single/3-Phase 200 V to 240 V (Power cable included)*	57,74
MBEG9A1BCP	90 W Single phase 100 V to 120 V	59
MBEG9A1BCPC	90 W Single phase 100 V to 120 V (Power cable included)*	59,74
MBEG9A5BCP	90 W Single/3-Phase 200 V to 240 V	59
MBEG9A5BCPC	90 W Single/3-Phase 200 V to 240 V (Power cable included)*	59,74

* This part number is the ordering part number for the amplifier and power cable, not for ordering amplifier only.

Model No.	Specifications	Page
MBEG (For GV series amplifier)		
MBEG1E1BCV	130 W Single phase 100 V to 120 V	21
MBEG1E1BCVC	130 W Single phase 100 V to 120 V (Power cable included)*	21,74
MBEG1E5BCV	130 W Single/3-Phase 200 V to 240 V	21
MBEG1E5BCVC	130 W Single/3-Phase 200 V to 240 V (Power cable included)*	21,74
MBEG5A1BCV	50 W Single phase 100 V to 120 V	17
MBEG5A1BCVC	50 W Single phase 100 V to 120 V (Power cable included)*	17,74
MBEG5A5BCV	50 W Single/3-Phase 200 V to 240 V	17
MBEG5A5BCVC	50 W Single/3-Phase 200 V to 240 V (Power cable included)*	17,74
MBEG9A1BCV	90 W Single phase 100 V to 120 V	19
MBEG9A1BCVC	90 W Single phase 100 V to 120 V (Power cable included)*	19,74
MBEG9A5BCV	90 W Single/3-Phase 200 V to 240 V	19
MBEG9A5BCVC	90 W Single/3-Phase 200 V to 240 V (Power cable included)*	19,74

* This part number is the ordering part number for the amplifier and power cable, not for ordering amplifier only.

Model No.	Specifications	Page
MBEK (For KV series amplifier)		
MBEK011BCV	100 W Single phase 100 V to 120 V	37
MBEK011BCVC	100 W Single phase 100 V to 120 V (Power cable included)*	37,74
MBEK015BCV	100 W Single/3-Phase 200 V to 240 V	37
MBEK015BCVC	100 W Single/3-Phase 200 V to 240 V (Power cable included)*	37,74
MBEK021BCV	200 W Single phase 100 V to 120 V	39
MBEK025BCV	200 W Single/3-Phase 200 V to 240 V	39
MBEK045BCV	400 W Single/3-Phase 200 V to 240 V	41
MBEK083BCV	750 W 3-Phase 200 V to 240 V	43
MBEK5A1BCV	50 W Single phase 100 V to 120 V	35
MBEK5A1BCVC	50 W Single phase 100 V to 120 V (Power cable included)*	35,74
MBEK5A5BCV	50 W Single/3-Phase 200 V to 240 V	35
MBEK5A5BCVC	50 W Single/3-Phase 200 V to 240 V (Power cable included)*	35,74

* This part number is the ordering part number for the amplifier and power cable, not for ordering amplifier only.

Model No.	Specifications	Page
MBMS (For KV series motor)		
MBMS011BLA	60 mm sq. Round shaft motor Without oil seal	37
MBMS011BLC	60 mm sq. Round shaft motor With oil seal	37
MBMS011BLN	60 mm sq. D-cut shaft motor Without oil seal	37
MBMS011BLQ	60 mm sq. D-cut shaft motor With oil seal	37
MBMS011BLS	60 mm sq. Keyway, center tap shaft motor Without oil seal	37
MBMS011BLU	60 mm sq. Keyway, center tap shaft motor With oil seal	37
MBMS012BLA	60 mm sq. Round shaft motor Without oil seal	37
MBMS012BLC	60 mm sq. Round shaft motor With oil seal	37
MBMS012BLN	60 mm sq. D-cut shaft motor Without oil seal	37
MBMS012BLQ	60 mm sq. D-cut shaft motor With oil seal	37
MBMS012BLS	60 mm sq. Keyway, center tap shaft motor Without oil seal	37
MBMS012BLU	60 mm sq. Keyway, center tap shaft motor With oil seal	37
MBMS021BLA	60 mm sq. Round shaft motor Without oil seal	39
MBMS021BLC	60 mm sq. Round shaft motor With oil seal	39
MBMS021BLN	60 mm sq. D-cut shaft motor Without oil seal	39
MBMS021BLQ	60 mm sq. D-cut shaft motor With oil seal	39
MBMS021BLS	60 mm sq. Keyway, center tap shaft motor Without oil seal	39
MBMS021BLU	60 mm sq. Keyway, center tap shaft motor With oil seal	39
MBMS022BLA	60 mm sq. Round shaft motor Without oil seal	39
MBMS022BLC	60 mm sq. Round shaft motor With oil seal	39
MBMS022BLN	60 mm sq. D-cut shaft motor Without oil seal	39
MBMS022BLQ	60 mm sq. D-cut shaft motor With oil seal	39
MBMS022BLS	60 mm sq. Keyway, center tap shaft motor Without oil seal	39
MBMS022BLU	60 mm sq. Keyway, center tap shaft motor With oil seal	39
MBMS042BLA	60 mm sq. Round shaft motor Without oil seal	41
MBMS042BLC	60 mm sq. Round shaft motor With oil seal	41
MBMS042BLN	60 mm sq. D-cut shaft motor Without oil seal	41

Model No.	Specifications	Page
MBMS (For KV series motor)		
MBMS042BLQ	60 mm sq. D-cut shaft motor With oil seal	41
MBMS042BLS	60 mm sq. Keyway, center tap shaft motor Without oil seal	41
MBMS042BLU	60 mm sq. Keyway, center tap shaft motor With oil seal	41
MBMS082BLA	80 mm sq. Round shaft motor Without oil seal	43
MBMS082BLC	80 mm sq. Round shaft motor With oil seal	43
MBMS082BLN	80 mm sq. D-cut shaft motor Without oil seal	43
MBMS082BLQ	80 mm sq. D-cut shaft motor With oil seal	43
MBMS082BLS	80 mm sq. Keyway, center tap shaft motor Without oil seal	43
MBMS082BLU	80 mm sq. Keyway, center tap shaft motor With oil seal	43
MBMS5AZBLA	38 mm sq. Round shaft motor Without oil seal	35
MBMS5AZBLC	38 mm sq. Round shaft motor With oil seal	35
MBMS5AZBLN	38 mm sq. D-cut shaft motor Without oil seal	35
MBMS5AZBLQ	38 mm sq. D-cut shaft motor With oil seal	35
MBMS5AZBLS	38 mm sq. Keyway, center tap shaft motor Without oil seal	35
MBMS5AZBLU	38 mm sq. Keyway, center tap shaft motor With oil seal	35

Model No.	Specifications	Page
MBMU (For GP series motor)		
MBMU1E1AB	90 mm sq. Pinion shaft motor	61
MBMU1E2AB	90 mm sq. Pinion shaft motor	61
MBMU5AZAB	80 mm sq. Pinion shaft motor	57
MBMU9A1AB	90 mm sq. Pinion shaft motor	59
MBMU9A2AB	90 mm sq. Pinion shaft motor	59

Model No.	Specifications	Page
MBMU (For GV series motor)		
MBMU1E1AZ	90 mm sq. Pinion shaft motor	21
MBMU1E2AZ	90 mm sq. Pinion shaft motor	21
MBMU1E1AS	90 mm sq. Round shaft motor	21
MBMU1E2AS	90 mm sq. Round shaft motor	21
MBMU5AZAX	80 mm sq. Pinion shaft motor	17
MBMU5AZAS	80 mm sq. Pinion shaft motor	17
MBMU9A1AZ	90 mm sq. Pinion shaft motor	19
MBMU9A2AZ	90 mm sq. Pinion shaft motor	19
MBMU9A1AS	90 mm sq. Round shaft motor	19
MBMU9A2AS	90 mm sq. Round shaft motor	19

Sales office

[Panasonic Sales Office of Motors]

(April.01.2015)

Country	Company Name [Category]	City	Address	TEL
				FAX
U.S.A	Panasonic Industrial Devices Sales Company of America [Sales office]	New Jersey	Two Riverfront Plaza, 7th Floor Newark, NJ 07102-5490 U.S.A	+1-800-228-2350
				—
Brazil	Panasonic do Brazil [Sales office]	Sao Paulo	Avenida do Cafe, 277 Torre A-8 Andar Jabaquara ZIP Code: 04311-900 Sao Paulo SP Brazil	+55-11-3889-4022 +55-11-3889-4103
Germany	Panasonic Industrial Devices Sales Europe GmbH [Sales office] [European Headquarter]	Munich	Hans-Pinsel-Strasse 2 · D - 85540 Haar · Germany	+49-89-46-159-0 +49-89-46-159-212
			e-mail	http://eu.industrial.panasonic.com/about-us/contact-us
			Web site	http://eu.industrial.panasonic.com/products/motors-compressors-pumps
	ghv Vertriebs-GmbH [Distributors]	Munich	Am Schammacher Feld 47 D-85567 Grafing b. Munich	+49(0)-80-92/81-89-0 +49(0)-80-92/81-89-99
			e-mail	http://www.ghv.de/kontakt.html
	Panasonic Electric Works Europe AG [Sales office] [European Headquarter]	Holzkirchen	Rudolf-Diesel-Ring 2, 83607 Holzkirchen, Deutschland	+49 (0) 8024 648-0 +49 (0) 8024 648-111
			e-mail	https://www.panasonic-electric-works.com/eu/93.htm
Web site			https://www.panasonic-electric-works.com/eu/index.htm	
Panasonic Electric Works Europe AG [Subsidiary]	Holzkirchen	Rudolf-Diesel-Ring 2, 83607 Holzkirchen, Deutschland	+49 (0) 8024 648-0 +49 (0) 8024 648-111	
		e-mail	https://www.panasonic-electric-works.com/eu/93.htm	
		Web site	https://www.panasonic-electric-works.com/eu/index.htm	
Italy	Lenze Italia S.r.l. [Distributors]	Milano	Viale Monza 338 20128 Milano	+39-02-270-98-1 +39-02-270-98-290
			e-mail	mail@lenzeitalia.it
			Web site	http://www.lenze.com/it-it/azienda/lenze-in-italia/
United Kingdom	Lenze Limited [Distributors]	Bedford	Priory Business Park, Bedford, MK44 3WH.	+44-1234-7532-00 +44-1234-7532-20
			e-mail	uk.sales@lenze.com
			Web site	http://www.lenze.com/en-gb/about-lenze/lenze-in-united-kingdom/
Romania	C.I.T. Automatizari SRL [Distributors]	Bucuresti	sos. Bucuresti, nr.63, Ciorogirla, Ilfov, RO-077055, ROMANIA	+40-21-255-0543 +40-21-255-0544
			e-mail	office@citautomatizari.ro
			Web site	http://www.citautomatizari.ro
Russia	Electroprivod Ltd. [Distributors]	St.Petersburg	Office 417, litera 43, Polustrovskiy avenue, Saint-Petersburg, Russia	+7-812-703-09-81 +7-812-493-27-26
			Web site	http://www.electroprivod.ru
Turkey	BOSTEK TEKNOLOJI GELISTIRME VE ROBOT SIST.SAN.TIC.A.S [Distributors]	Izmir	10042 SOK.NO:10 A.O.S.B CIGLI-IZMIR, TURKEY	+90 232 433 8515 +90 232 433 8881
			e-mail	sales@bostek.com.tr
			Web site	http://www.bostek.com.tr/
	Savior Kontrol Otomasyon [Distributors]	Istanbul	Des Sanayi Sitesi 104 Sokak A07 Blok No:02 Yukari Dudullu Ümraniye Istanbul Turkey	+90-216-466-3683 +90-216-466-3685
			e-mail	info@savior.com.tr
			Web site	http://www.savior.com.tr/
China	Panasonic Industrial Devices Sales (Hong Kong) Co.,Ltd. (PIDSHK) [Sales office]	Hong kong	Top Floor, South Wing, ChinaChem Gloden Plaza, 77 Mody Road, S.T.S. East, Kowloon, HongKong	+852-2529-7322 +852-2598-9743
			Panasonic Industrial Devices Sales (China) Co.,Ltd. (PIDSCN) [Sales office]	Shanghai
	Panasonic Industrial Devices Sales (China) Co.,Ltd. (PIDSCN) [Sales office]	Shenzhen	8/F, Tower Three, Kerry Plaza, 1-1 Zhongxinsi Road, Futian District, Shenzhen, China	

Country	Company Name [Category]	City	Address	TEL
				FAX
Korea	Panasonic Industrial Devices Sales Korea Co., Ltd. (PIDSKR) [Sales office]	Seoul	6F DONG-IL Tower 38, Teheran-ro 114-gil, Gangnam-gu, Seoul, 135-851, Korea	+82-2-795-9600 +82-2-2052-1053
Taiwan	Panasonic Industrial Devices Sales Taiwan Co.,Ltd. [Sales office]	Taipei	12F, No.9, SongGao Rd., Taipei 110, Taiwan, R.O.C.	+886-2-2757-1900 +886-2-2757-1977
India	Industrial Division, Panasonic India Pvt Ltd. [Sales office]	Gurgaon, Haryana	12th Floor, Ambience Commercial, Behind Ambience Mall, Gurgaon - 122002, Haryana, India	+91-124-6670400 +91-124-6670338
			Web site	http://industrial.panasonic.com/sa/products/motors-compressors/fa-motors
	Lubi Electronics [Distributors]	Gandhinaga, Gujarat	Sardar Patel Ring Road, Near Bright School, Nana Chiloda, Dist.: Gandhinagar - 382330, Gujarat, India	+91-79-39845300 +91-79-39845599
			Web site	http://www.lubielelectronics.com
	Luna Bearings [Distributors]	Mumbai, Maharashtra	59, Bibijan Street, 2nd Floor, Moiz Manzil, Mumbai - 400003, Maharashtra, India	+91-22-23455052 +91-22-23427773
			Web site	http://www.lunabearings.com
	Vashi Electricals Pvt. Ltd. [Distributors]	Mumbai, Maharashtra	A/6, Plot No.74, Shree Ganesh Complex, Behind Gupta Compound, Dapole Road, Mankoli Naka, Bhiwandi - 421305, Maharashtra, India	+91-2522-661600 +91-2522-661620
			Web site	http://www.vashielectricals.com
South-eastern Asia	Panasonic Industrial Devices Sales Asia Pte.Ltd. [Sales office]	Singapore	No.3 Bedok South Road Singapore 469269	+65-6390-3718 +65-9435-6844
			Intermech Machinery Pte. Ltd. [Distributors]	Singapore
	Web site	http://www.intermech.com.sg		
	Panamech Machinery Sdn Bhd [Distributors]	Kuala Lumpur	No.14, Lorong Sanggul 1C, Bandar Puteri, 41200 Klang, Selangor Darul Ehsan	+60-3-5161-7876 +60-3-5161-7136
			Web site	http://panamech.com.my/
	Panamech (PG) Sdn Bhd [Distributors]	Penang	Sri Relau Komplex, Unit 1-3-11, Persiaran Bukit Jambul 1, 11900 Penang	+60-4-643-8266 +60-4-645-1639
			Web site	http://panamech.com.my/
	Premier Automation Center Co.,Ltd. [Distributors]	Bangkok	73 Soi Ladkrabang 30 Ladkrabang Ladkrabang Bangkok 10520	+66-2181-2299 +66-2181-2288
			Web site	http://www.premier-ac.co.th
Plenty Island (Thai) Co.,Ltd. [Distributors]	Bangkok	3 Soi Charoenrat 10, Charoenrat Road., Bangkoklo, Bangkokorlaem, Bangkok 10120	+66-2291-9933 +66-2291-2065	
		Web site	http://www.plenty.co.th	
Seng Charoen Muang Co.,Ltd. [Distributors]	Bangkok	12/349 Moo 15, Bangkaew, Bangplee, Samutprakam 10540	+66-2397-9577 +66-2361-8207	
		Web site	http://www.sengscm.com	
PT. Handal Yesindo Sejahtera [Distributors]	Surabaya	Jl. Raya Kutisari 8A, Surabaya, Indonesia	+62-31-843-8844 +62-31-841-4333	
		Web site	http://www.handalyesindo.com	
PT.Riasarana Electrindo [Distributors]	Jakarta	Jl. Prof. Dr. Latumenten Grogol Permai blok D No. 8-15 Jakarta 11460, Indonesia	+62-21-564-9178 +62-21-566-7405	
		Web site	http://www.risacorps.com	
Movaflex Designs Unlimited, Inc. [Distributors]	Manila	136 Calbayog Street, Mandaluyong City, Metro Manila, Philippines.	+63-2-881-3636 +63-2-998-3881	
		Web site	http://www.movaflex.com/	