

Features

- High Rejection
- Low Loss

Description

Surface mount, silver (Ag) coated neodymium ceramic duplexer.

Weight: 3.9 grams typical

Material: Filter is composed of a ceramic block plated with Ag and a shield made of nickel silver plated steel.

Filter complies with RoHS standards.

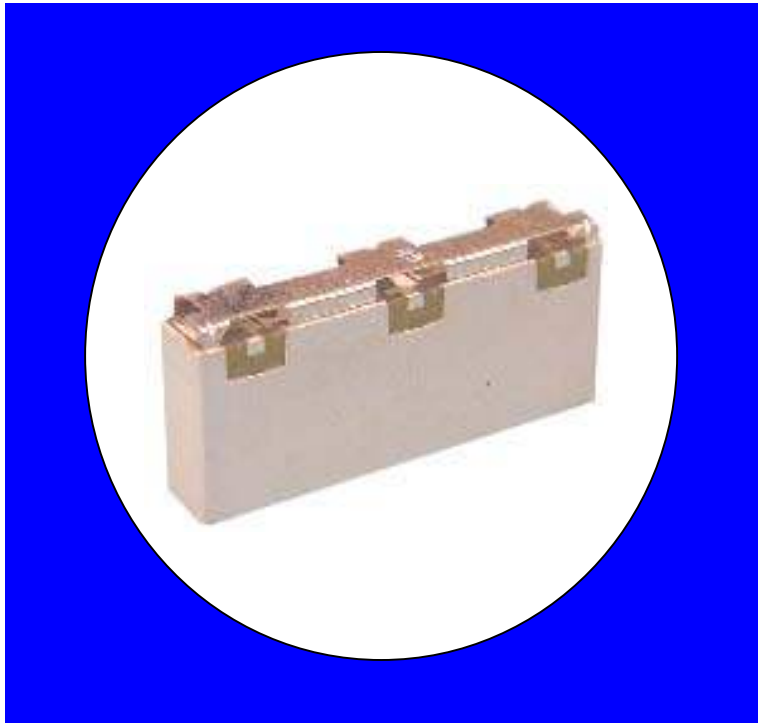

Electrical Specifications

Parameter	Frequency (MHz)	Typical @ 25°C	Spec. @ 25°C	Spec. -40°C to +85°C
Low Band Response				
Passband Insertion Loss	806 - 824	2.4 dB	2.8 dB max	3.0 dB max
Passband Return Loss @ TX	806 - 824	13.5 dB	10.0 dB min	10.0 dB min
Passband Return Loss @ ANT	806 - 824	13.5 dB	10.0 dB min	10.0 dB min
Attenuation:	851 - 869	53 dB	50.0 dB min	50.0 dB min
High Band Response				
Passband Insertion Loss	851 - 869	2.5 dB	2.8 dB max	3.0 dB max
Passband Return Loss @ RX	851 - 869	13.5 dB	10.0 dB min	10.0 dB min
Passband Return Loss @ ANT	851 - 869	13.5 dB	10.0 dB min	10.0 dB min
Attenuation:	806 - 824	48 dB	45.0 dB min	45.0 dB min
	896 - 941	28.0 dB	25.0 dB min	25.0 dB min
TX _ RX Response				
Isolation at Low Band	806 - 824	50 dB	48.0 dB min	48.0 dB min
Isolation at High Band	851 - 869	54 dB	52.0 dB min	52.0 dB min
Power into any port			3 Watt max	

Note: Supplier shall test each filter to the critical electrical specifications of the above table. Any subsequent audits may deviate from in value due to measurement repeatability among different test systems. Such deviations shall not exceed the following limits:

Specification Allowance	
Insertion Loss	0.1 dB
Return Loss	1.0 dB
Stopbands	1.0 dB

*This product is covered by one or more of the following U.S. and foreign patents including: US 4,692,726;US 4,742,562; US 4,800,348;US 4,829,274;US 5,146,193;EP 0573597;DE 0573597;FR 0573597;JP 508149/92;KR 142171;US 5,162,760;US 5,218,329;US 5,250,916;US 5,327,109;US 5,488,335;CA 2114029;FR 9306297;GB 2273393;JP 3205337;KR 115113;CN 93106228.4;US 5,512,866;EP 0706719;DE 0706719;FR 0706719;GB 0706719;US 5,602,518;US 5,721,520;US 5,745,018;EP 0910875;DE 0910875;DK 0910875;FR 0910875;GB 0910875;IE 0910875;JP 505182/98;KR 10-323013;US 5,994,978;US 6,462,629;CN 00810420.4;US 6,559,735;US 6,650,202;US 6,834,429. Other US and foreign patents pending.

CTS Corporation 2006 reserves all copyrights in the layout, design and configuration of the patterns on this product.

Mechanical Drawing

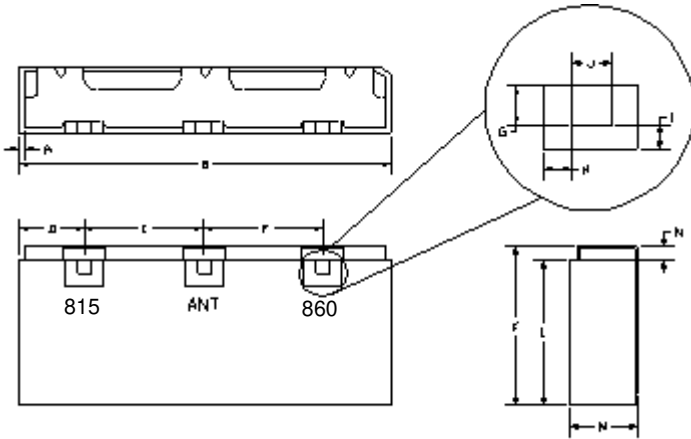

Dim	Nominal (mm)	Tolerance (mm) +/- or max
A		
B	21.54	max
C		
D	2.72	0.20
E	7.95	0.20
F	7.95	0.20
G	0.76	0.13
H	1.00	0.13
I	1.00	0.13
J	0.76	0.13
K	9.80	0.30
L	8.90	0.20
M	4.00	max
*N	0.80	0.13

Electrical response

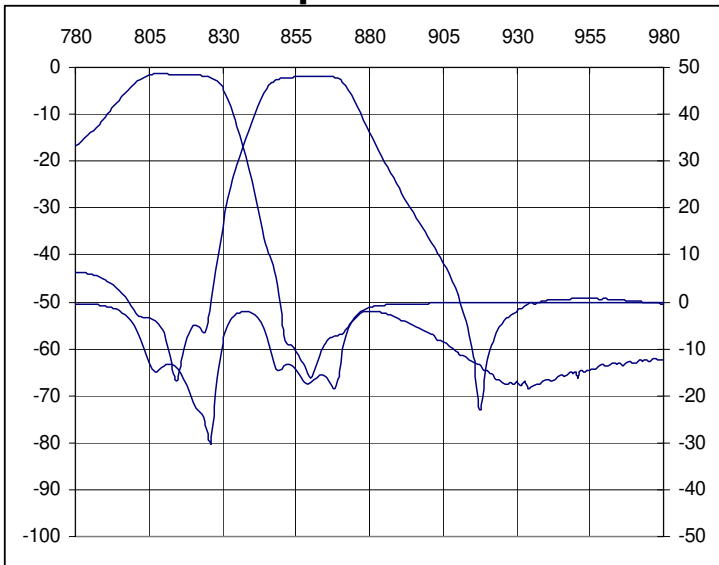

PCB Layout

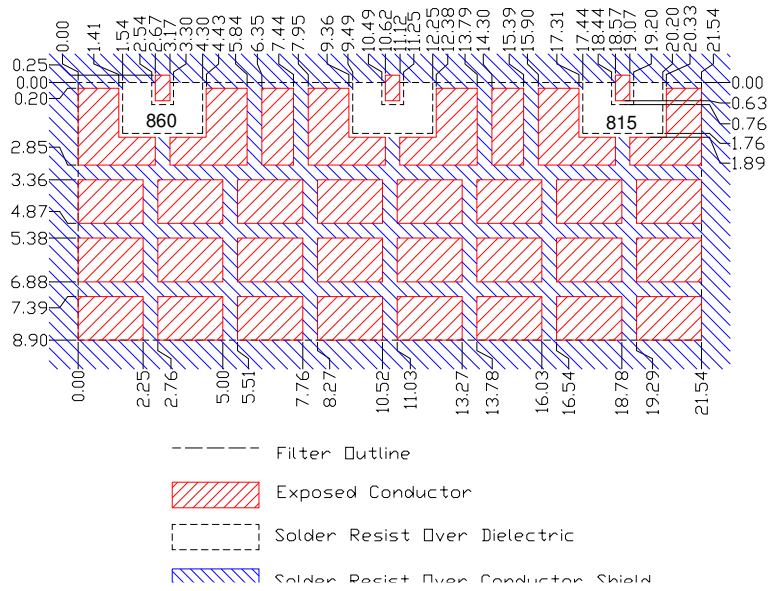

Packaging and Marking

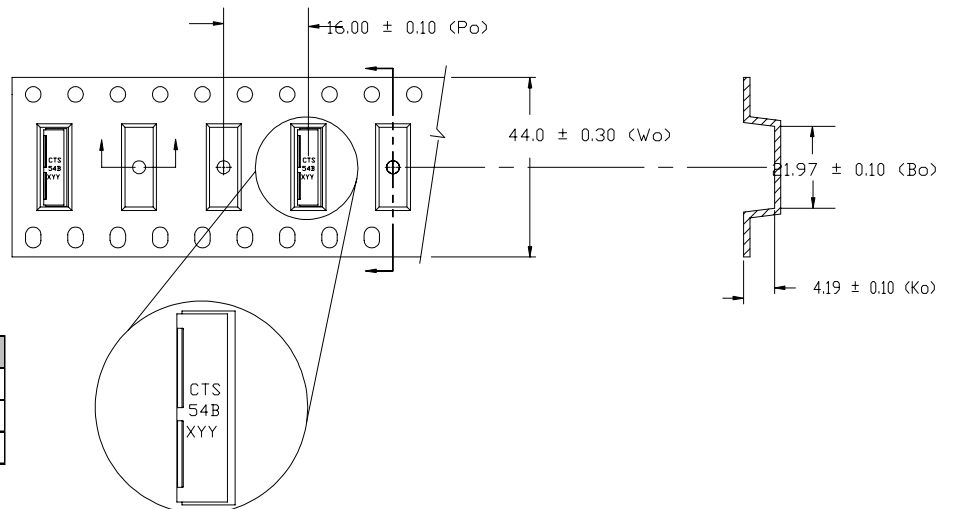
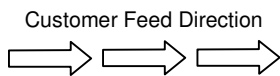

DIMENSION	UNITS	SPECIFICATION
REEL DIAMETER	mm	330
REEL WEIGHT	kg	2.6
REEL QUANTITY	ea.	500