

DO NOT SCALE FROM THIS PRINT

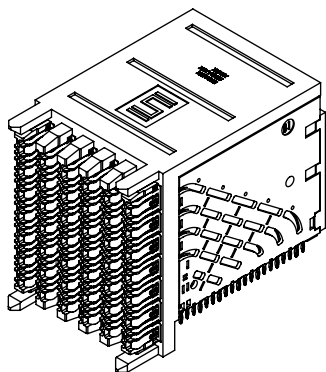

No OF PAIRS PER COLUMN

-6

COLUMNS

-06

-08

-10

-12

COLUMN PITCH

-2.0: 2.0 mm

PLATING SPECIFICATION

-S: 30µ" SELECTIVE GOLD IN CONTACT AREA, MATTE TIN ON TAIL

ORIENTATION

-RA: RIGHT ANGLE

KEYING

(ONLY AVAILABLE WITH -L OR -R GUIDANCE)
BLANK: NO KEYING
-A THRU -H: DENOTES POSITION OF FLAT ON KEY
(SEE KEYING POSITION TABLE, SHT 4)

GUIDANCE

BLANK: NONE
-L: LEFT (SEE FIG 3, SHT 5)
-R: RIGHT (SEE FIG 2, SHT 4)

PIN CONFIGURATION

-1: STANDARD

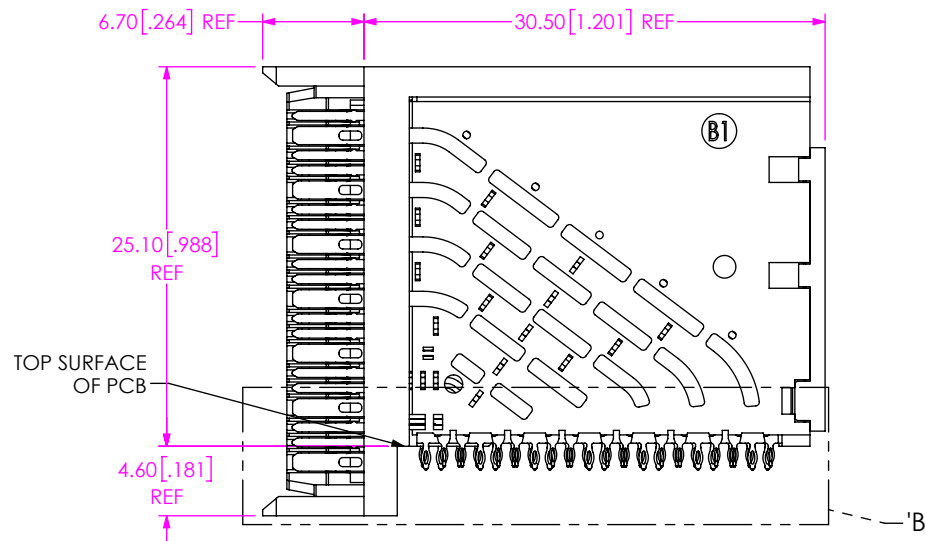
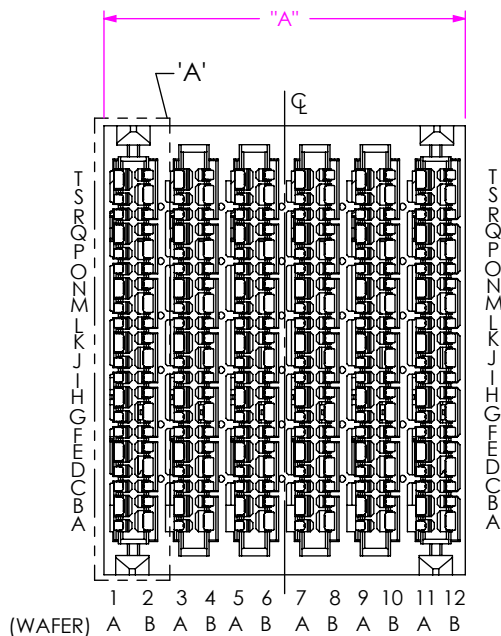

FIG 1
EBTM-6-12-2.0-X-RA-1 SHOWN

TABLE 1				
COLUMNS	"A"	"B"	"C"	
-06	11.90 [0.469]	10.00 [0.394]	5.20	[0.205]
-08	15.90 [0.626]	14.00 [0.551]	7.20	[0.283]
-10	19.90 [0.783]	18.00 [0.709]	9.20	[0.362]
-12	23.90 [0.941]	22.00 [0.866]	11.20	[0.441]

NOTES:

1. MINIMUM PUSHOUT FORCE: 2.22N [.5 LB].
2. CONTACT SAMTEC FOR CONNECTOR PRESS FIT INSTRUCTIONS.
3. TRAYS TO BE STANDARD PACKAGING.
4. ORDERS WILL BE PACKAGED ACCORDING TO THE SAMTEC PACKAGING EFFICIENCY STANDARDS (SPES) FOUND ON WWW.SAMTEC.COM.

UNLESS OTHERWISE SPECIFIED, DIMENSIONS ARE IN MILLIMETERS [INCHES].

TOLERANCES ARE:

DECIMALS ANGLES
X.X: ±0.3 [.01] 2°
X.XX: ±0.10 [.004]
X.XXX: ±0.050 [.0019]

PROPRIETARY NOTE

THIS DOCUMENT CONTAINS CONFIDENTIAL AND PROPRIETARY INFORMATION AND ALL DESIGN, MANUFACTURING, REPRODUCTION, USE, PATENT RIGHTS AND SALES RIGHTS ARE EXPRESSLY RESERVED BY SAMTEC, INC. THIS DOCUMENT SHALL NOT BE DISCLOSED, IN WHOLE OR PART, TO ANY UNAUTHORIZED PERSON OR ENTITY NOR REPRODUCED, TRANSFERRED OR INCORPORATED IN ANY OTHER PROJECT IN ANY MANNER WITHOUT THE EXPRESS WRITTEN CONSENT OF SAMTEC, INC.

MATERIAL: DO NOT SCALE DRAWING SHEET SCALE: 2:1

INSULATOR: LCP, UL 94-V0; COLOR: BLACK
CONTACT: COPPER ALLOY
SHIELD: COPPER ALLOY



520 PARK EAST BLVD, NEW ALBANY, IN 47150
PHONE: 812-944-6733 FAX: 812-948-5047
e-Mail: info@SAMTEC.com code 53322

DESCRIPTION:
EXAMAX™ RIGHT ANGLE HEADER ASSEMBLY

DWG. NO.
EBTM-6-XX-2.0-X-RA-X-X-X

BY: B BLESSING 9/5/17 SHEET 1 OF 5

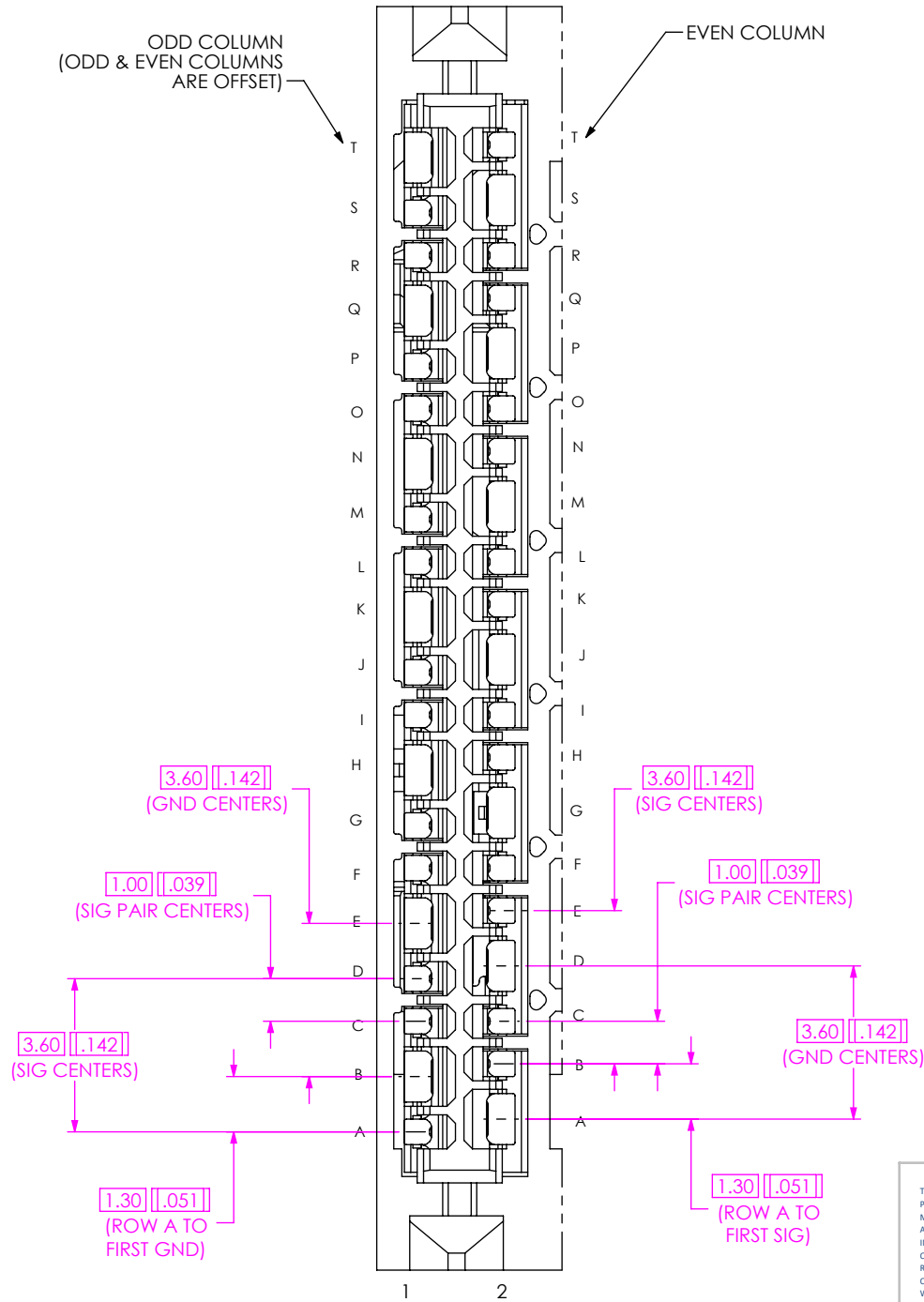

DETAIL 'A'
SCALE 6 : 1

PROPRIETARY NOTE
 THIS DOCUMENT CONTAINS CONFIDENTIAL AND PROPRIETARY INFORMATION AND ALL DESIGN, MANUFACTURING, REPRODUCTION, USE, PATENT RIGHTS AND SALES RIGHTS ARE EXPRESSLY RESERVED BY SAMTEC, INC. THIS DOCUMENT SHALL NOT BE DISCLOSED, IN WHOLE OR PART, TO ANY UNAUTHORIZED PERSON OR ENTITY NOR REPRODUCED, TRANSFERRED OR INCORPORATED IN ANY OTHER PROJECT IN ANY MANNER WITHOUT THE EXPRESS WRITTEN CONSENT OF SAMTEC, INC.

DO NOT SCALE DRAWING

SHEET SCALE: 2:1



520 PARK EAST BLVD. NEW ALBANY, IN 47150
 PHONE: 812-944-6733 FAX: 812-948-5047
 e-Mail info@SAMTEC.com code 55322

DESCRIPTION:
 EXAMAX™ RIGHT ANGLE HEADER ASSEMBLY

DWG. NO.
 EBTM-6-XX-2.0-X-RA-X-X-X

BY: B BLESSING 9/5/17

SHEET 2 OF 5

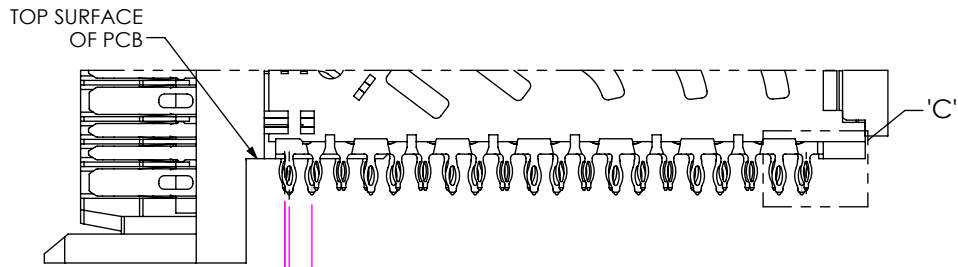

1.200 [0.0472] (TYP)

3.90 [0.154]

4.10 [0.161]

DETAIL 'B'

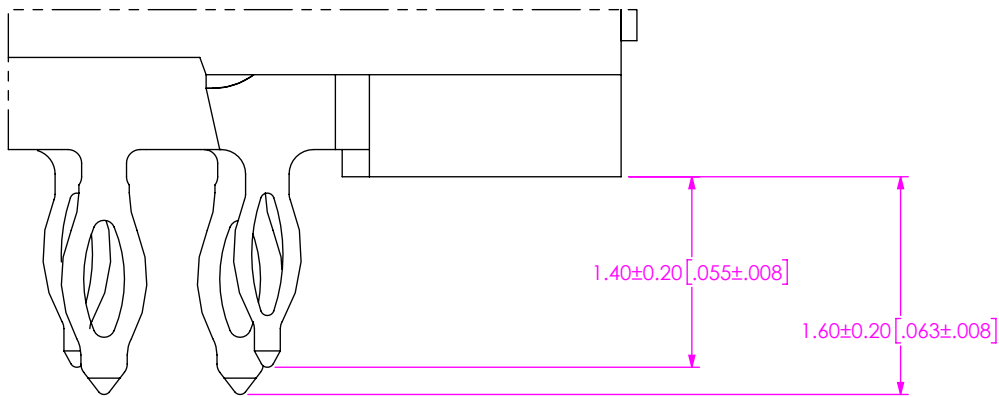

DETAIL 'C'
SCALE 18:1

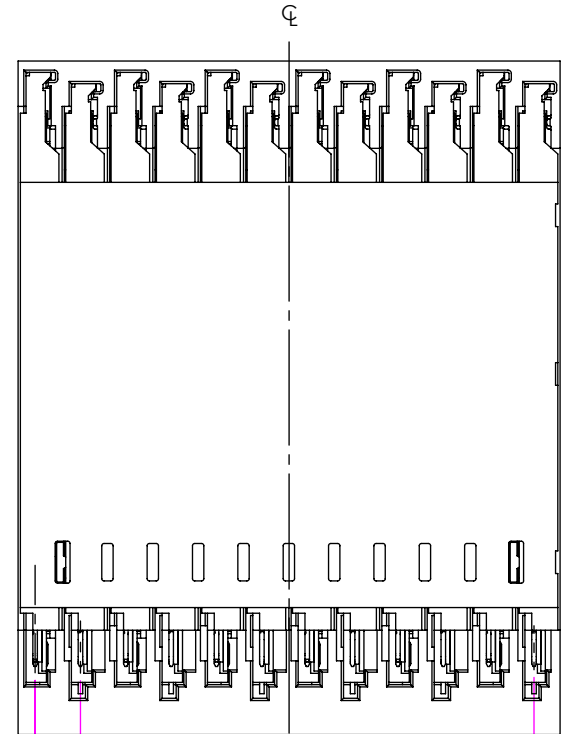

2.00 [0.079] (9 PLCS)
(TOL. NON-ACCUM)

"C"
(TBL 1, SHT 1)

"B"
(TBL 1, SHT 1)

BACK VIEW

PROPRIETARY NOTE
THIS DOCUMENT CONTAINS CONFIDENTIAL AND PROPRIETARY INFORMATION AND ALL DESIGN, MANUFACTURING, REPRODUCTION, USE, PATENT RIGHTS AND SALES RIGHTS ARE EXPRESSLY RESERVED BY SAMTEC, INC. THIS DOCUMENT SHALL NOT BE DISCLOSED, IN WHOLE OR PART, TO ANY UNAUTHORIZED PERSON OR ENTITY NOR REPRODUCED, TRANSFERRED OR INCORPORATED IN ANY OTHER PROJECT IN ANY MANNER WITHOUT THE EXPRESS WRITTEN CONSENT OF SAMTEC, INC.

DO NOT SCALE DRAWING

SHEET SCALE: 3:1



520 PARK EAST BLVD, NEW ALBANY, IN 47150
PHONE: 812-944-6733 FAX: 812-948-5047
e-Mail info@SAMTEC.com code 55322

DESCRIPTION:
EXAMAX™ RIGHT ANGLE HEADER ASSEMBLY

DWG. NO.
EBTM-6-XX-2.0-X-RA-X-X-X

BY: B BLESSING 9/5/17 SHEET 3 OF 5

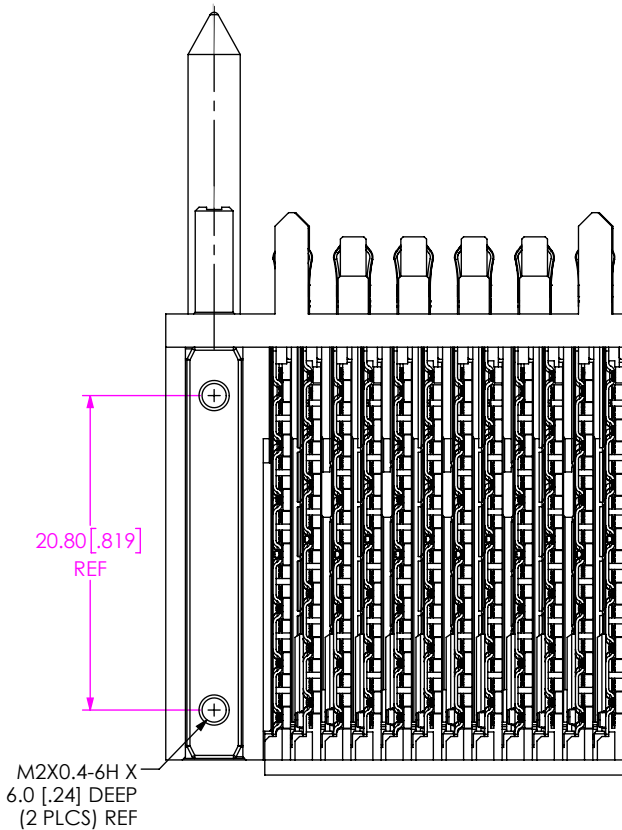
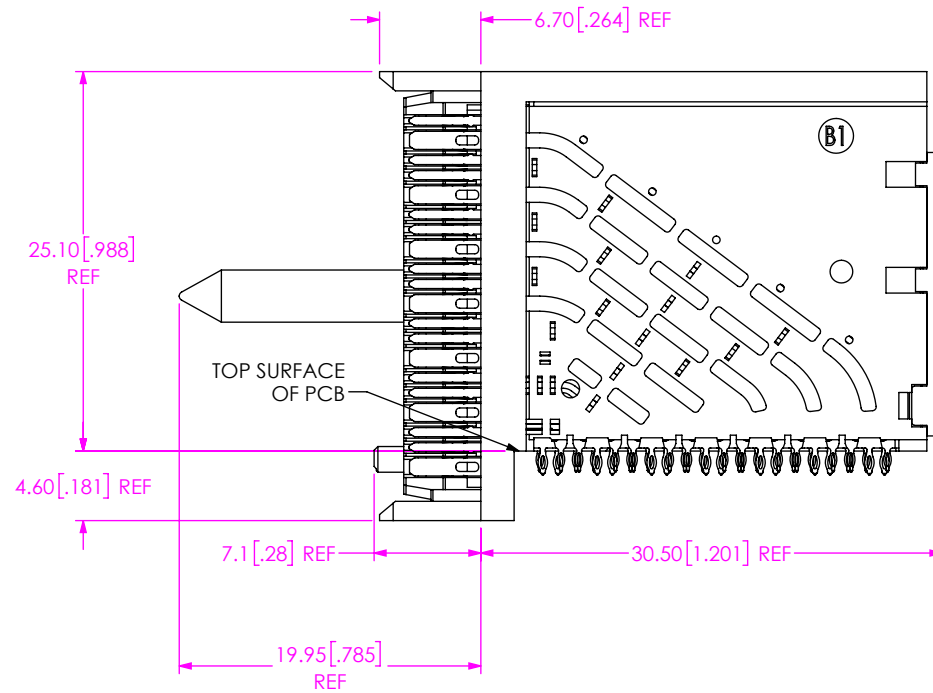
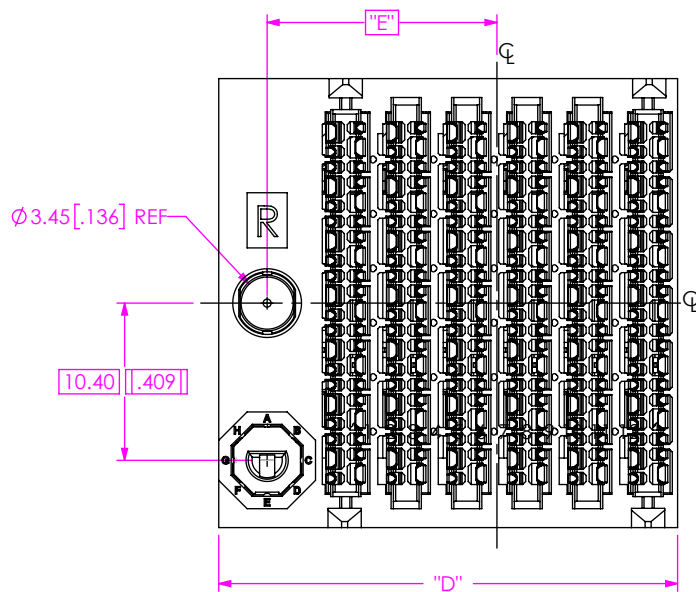

TABLE 2

COLUMNS	"D"	"E"
-06	18.35 [0.722]	9.20 [0.362]
-08	22.35 [0.880]	11.20 [0.441]
-10	26.35 [1.037]	13.20 [0.520]
-12	30.35 [1.195]	15.20 [0.598]

KEYING POSITION TABLE

		KEYING							
		-A	-B	-C	-D	-E	-F	-G	-H
-R / -L	H								
	G								

FIG 2
 RIGHT GUIDANCE
 EBTM-6-12-2.0-X-RA-X-R-A SHOWN
 (DIFFERENT AS SHOWN, OTHERWISE SAME AS FIG 1)

PROPRIETARY NOTE
 THIS DOCUMENT CONTAINS CONFIDENTIAL AND PROPRIETARY INFORMATION AND ALL DESIGN, MANUFACTURING, REPRODUCTION, USE, PATENT RIGHTS AND SALES RIGHTS ARE EXPRESSLY RESERVED BY SAMTEC, INC. THIS DOCUMENT SHALL NOT BE DISCLOSED, IN WHOLE OR PART, TO ANY UNAUTHORIZED PERSON OR ENTITY NOR REPRODUCED, TRANSFERRED OR INCORPORATED IN ANY OTHER PROJECT IN ANY MANNER WITHOUT THE EXPRESS WRITTEN CONSENT OF SAMTEC, INC.

DO NOT SCALE DRAWING

SHEET SCALE: 1.5:1



520 PARK EAST BLVD, NEW ALBANY, IN 47150
 PHONE: 812-944-6733 FAX: 812-948-5047
 e-Mail info@SAMTEC.com code 55322

DESCRIPTION:
 EXAMAX™ RIGHT ANGLE HEADER ASSEMBLY

DWG. NO.
EBTM-6-XX-2.0-X-RA-X-X-X

BY: B BLESSING 9/5/17 SHEET 4 OF 5

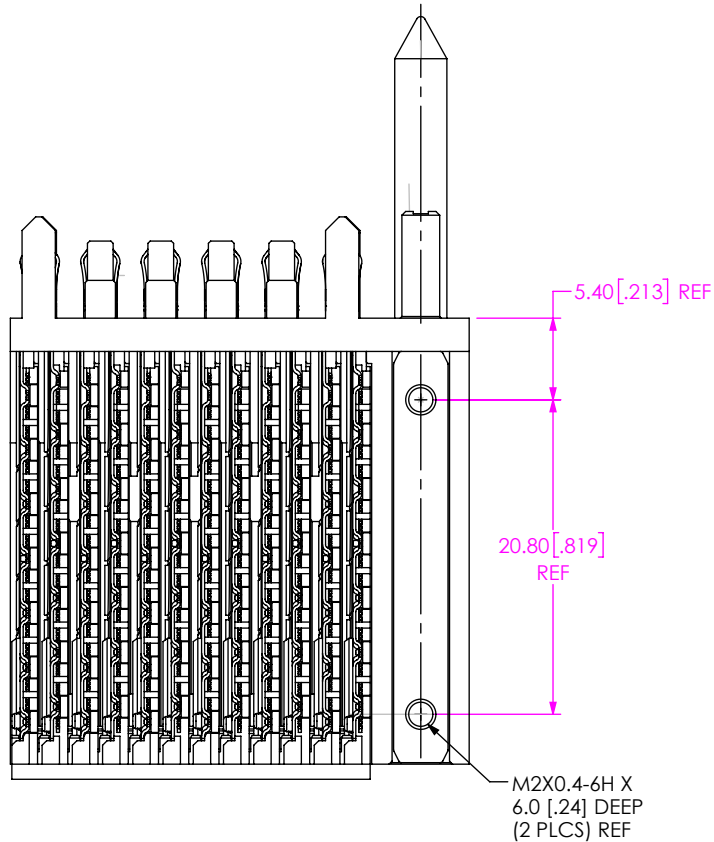
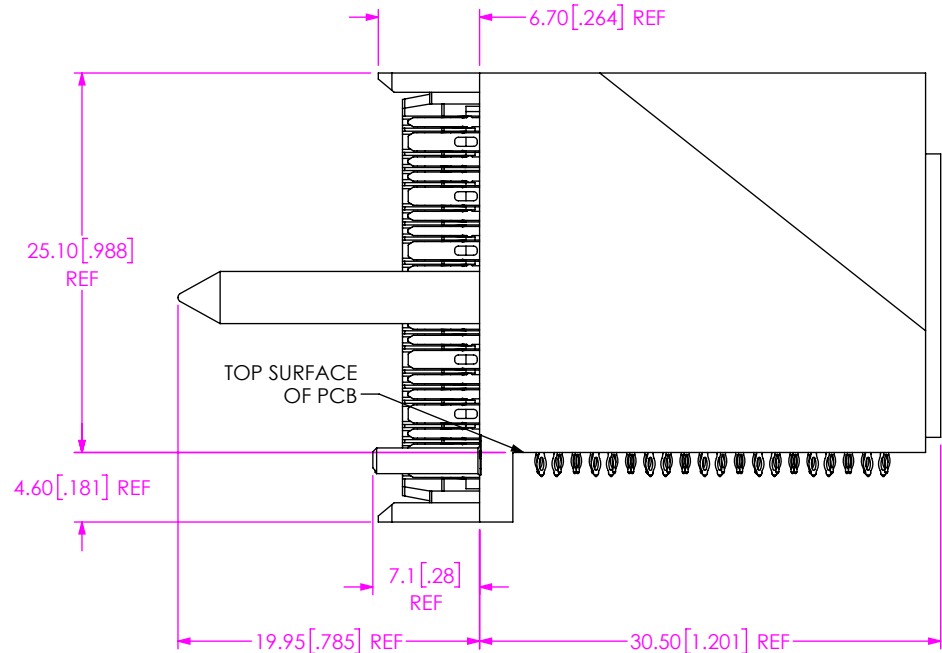
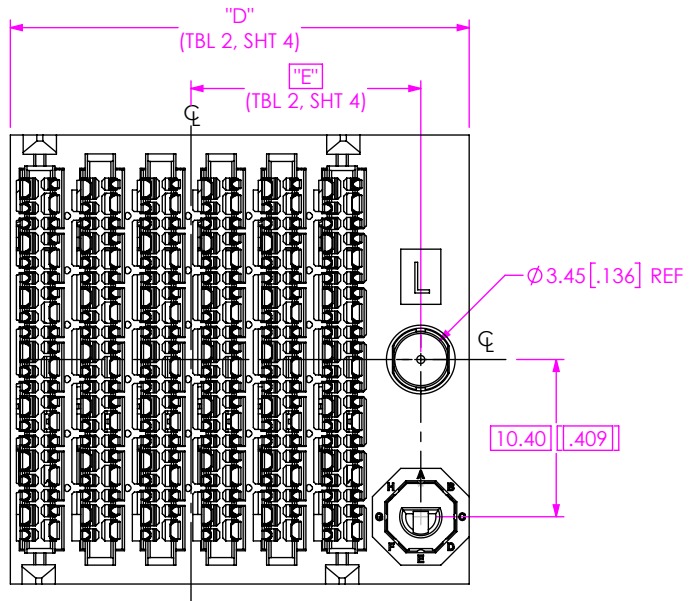

FIG 3
LEFT GUIDANCE
EBTM-6-12-2.0-X-RA-1-L-A SHOWN
(DIFFERENT AS SHOWN, OTHERWISE SAME AS FIG 2)

PROPRIETARY NOTE
THIS DOCUMENT CONTAINS CONFIDENTIAL AND PROPRIETARY INFORMATION AND ALL DESIGN, MANUFACTURING, REPRODUCTION, USE, PATENT RIGHTS AND SALES RIGHTS ARE EXPRESSLY RESERVED BY SAMTEC, INC. THIS DOCUMENT SHALL NOT BE DISCLOSED, IN WHOLE OR PART, TO ANY UNAUTHORIZED PERSON OR ENTITY NOR REPRODUCED, TRANSFERRED OR INCORPORATED IN ANY OTHER PROJECT IN ANY MANNER WITHOUT THE EXPRESS WRITTEN CONSENT OF SAMTEC, INC.

DO NOT SCALE DRAWING

SHEET SCALE: 2:1



520 PARK EAST BLVD, NEW ALBANY, IN 47150
PHONE: 812-944-6733 FAX: 812-948-5047
e-Mail info@SAMTEC.com code 55322

DESCRIPTION:
EXAMAX™ RIGHT ANGLE HEADER ASSEMBLY

DWG. NO.
EBTM-6-XX-2.0-X-RA-X-X-X

BY: B BLESSING 9/5/17 SHEET 5 OF 5